

Въпрос № 21

**ВИНТОГАЕЧНИ ПРЕДАВКИ (ВГП) – ВИДОВЕ,
ЯКОСТНО ОРАЗМЕРЯВАНЕ, КПД**



Схеми на ВГП

1

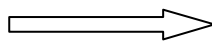
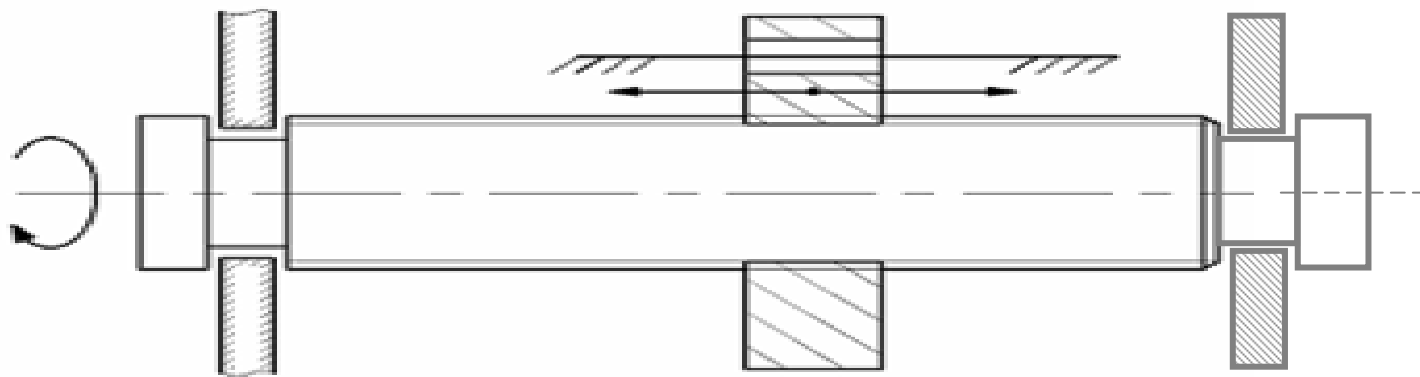

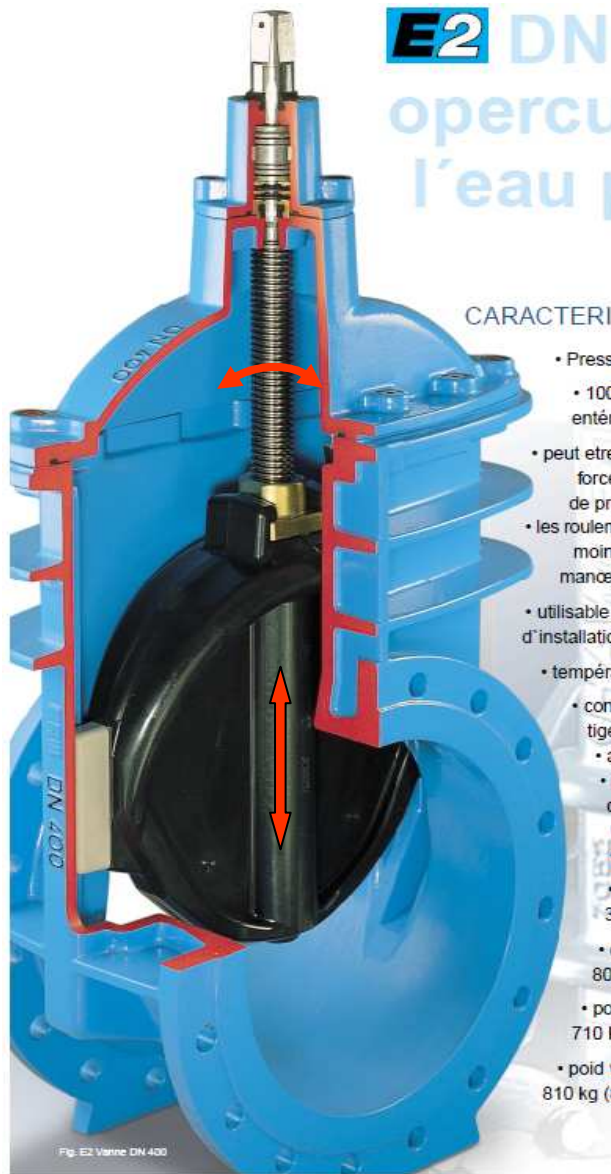

E2 DN
opercu
l'eau p

CARACTERI

- Press
- 100
entér
- peut etre
force
de pn
- les roulen
moin
manoe
- utilisable
d'installatic
- tempér:
- con
tige
- 2
- 1
- 3
- 80
- po
710 k
- poids
810 kg (

Pg. E2 Vanne DN 400



2

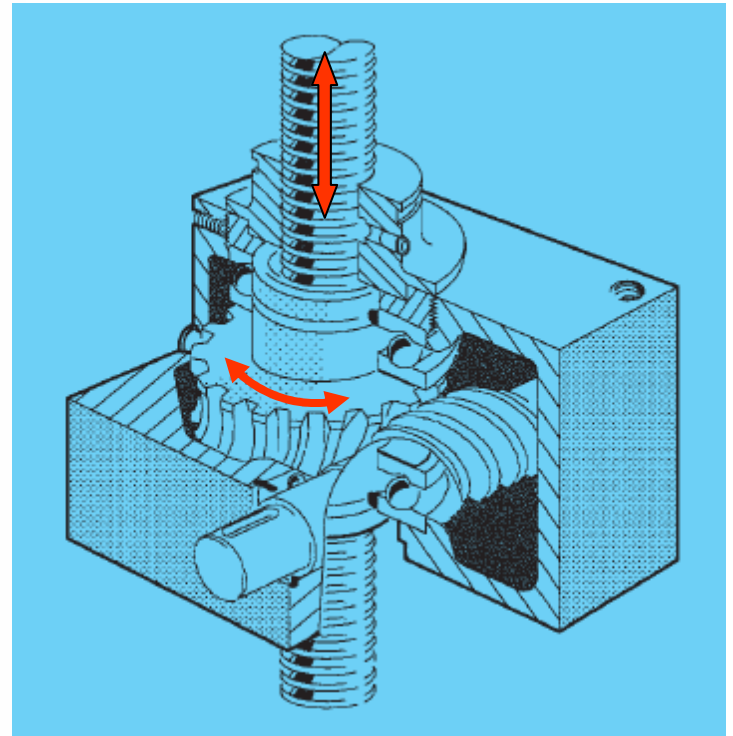
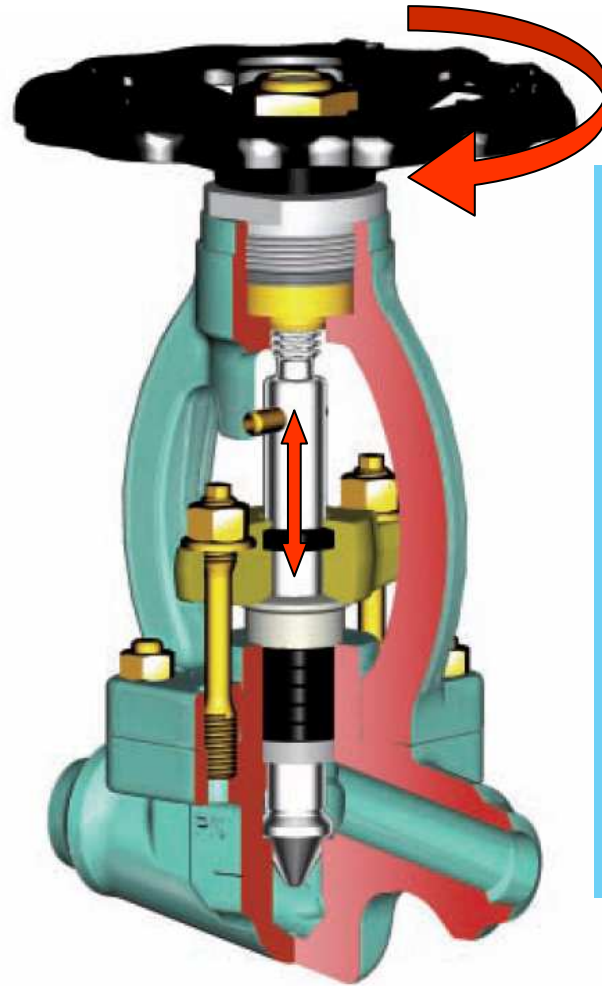
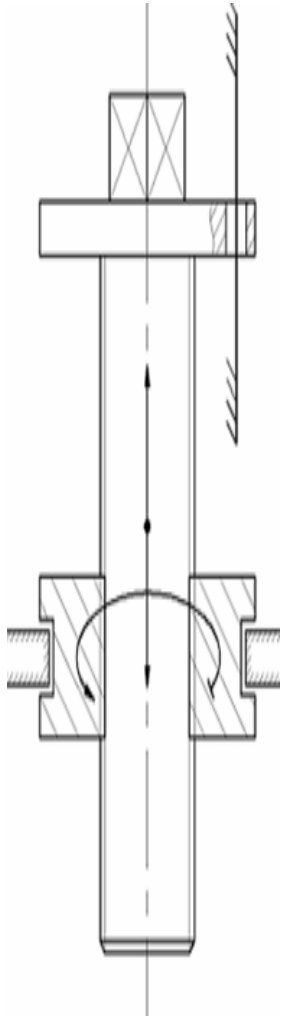

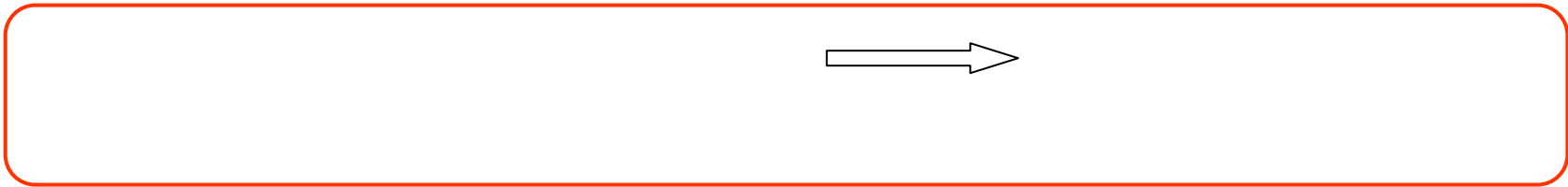

3

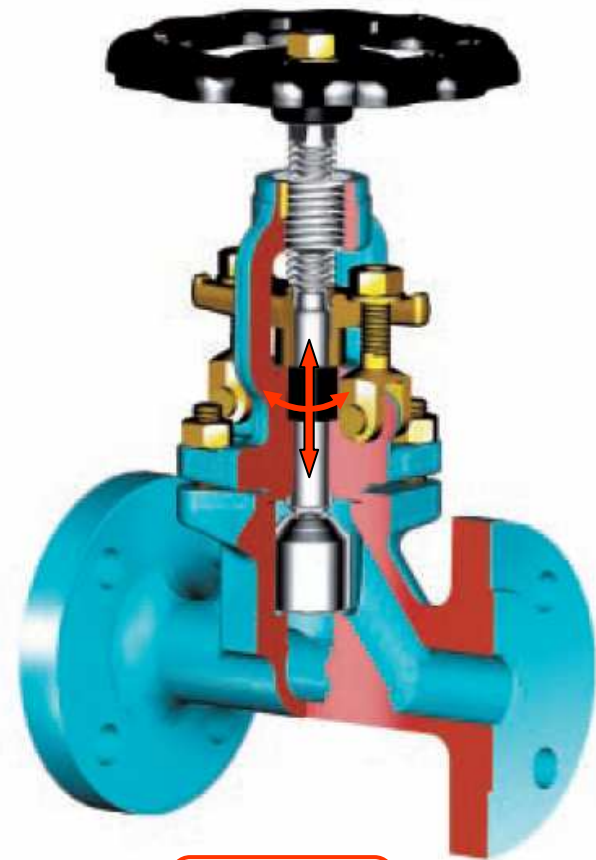
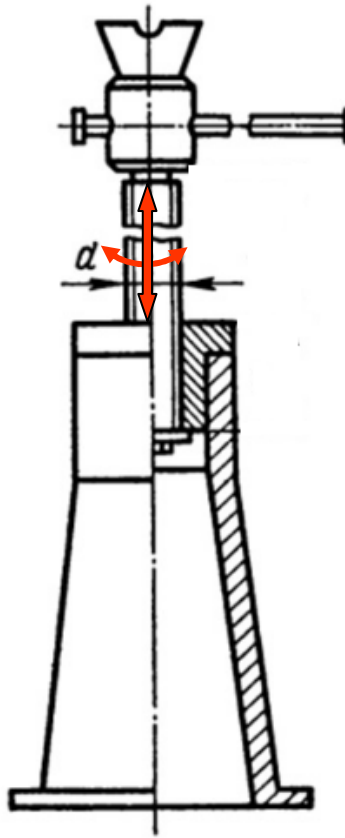
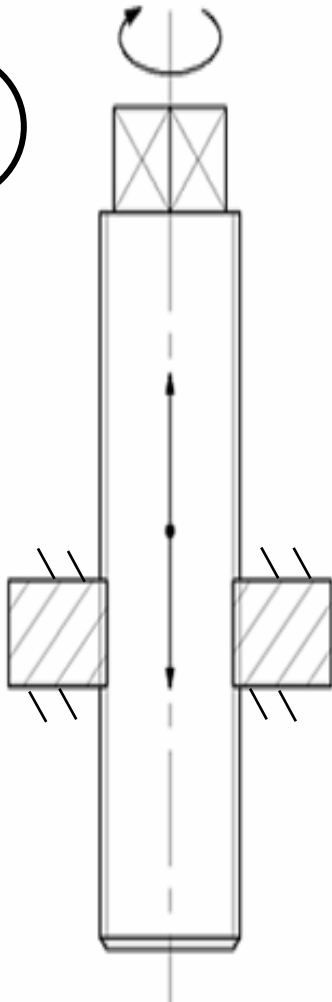

Класификация на ВГП според вида на триенето

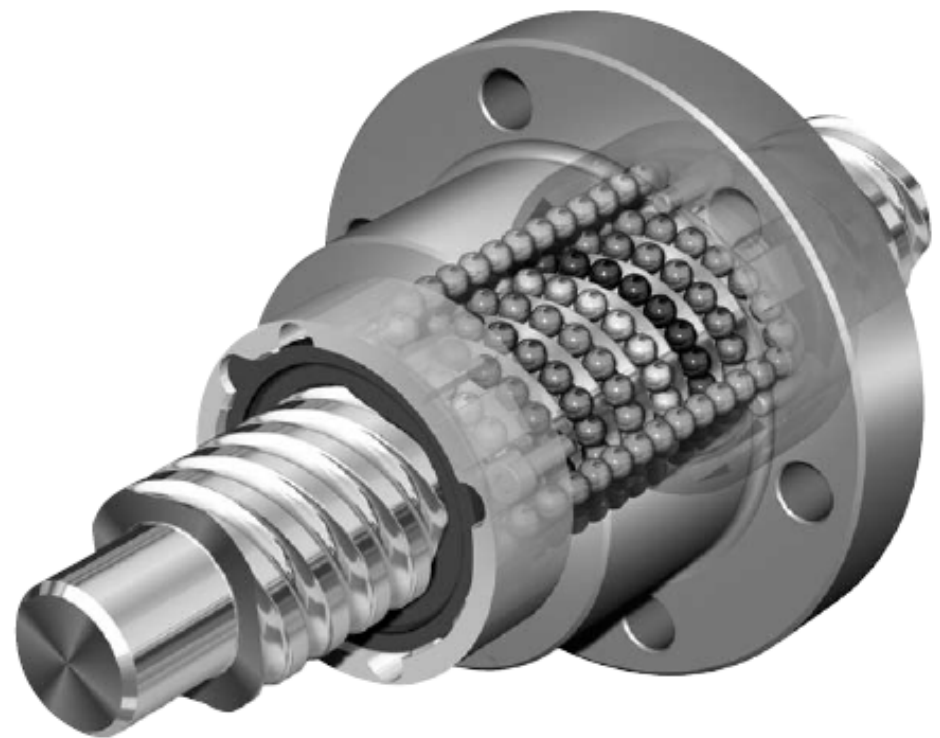
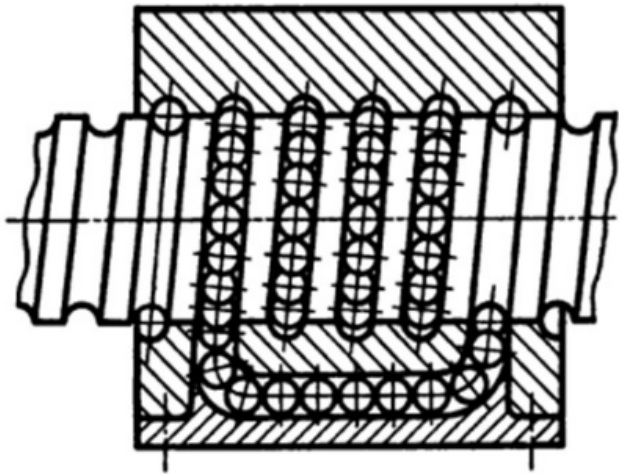
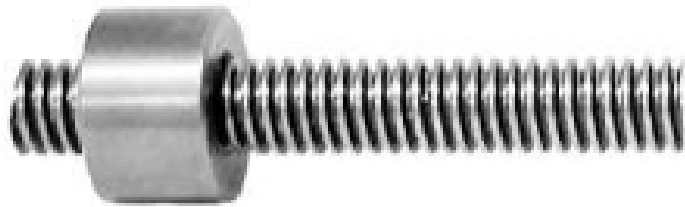

Кинематичен параметър на ВГП

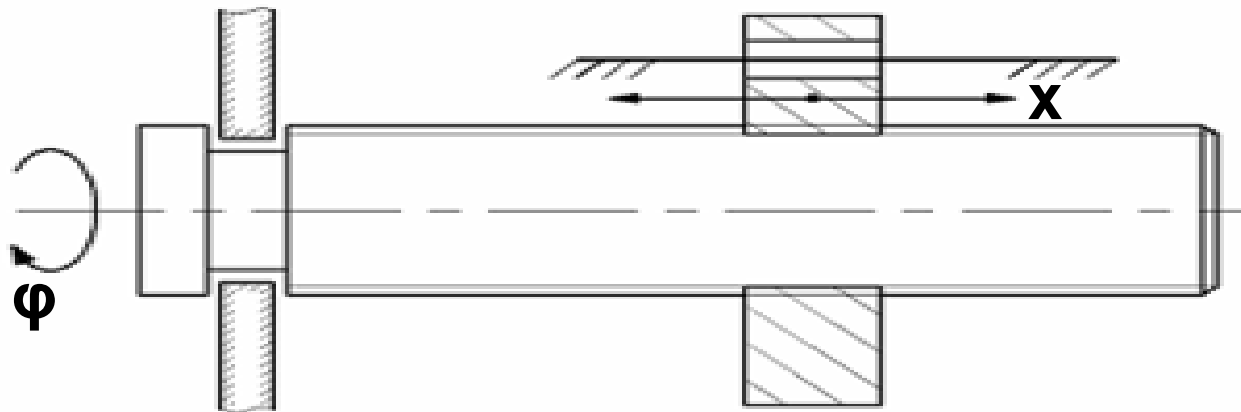

φ – ъгъл на завъртане в rad , x – кинематичен параметър на ВГП

Якостно пресмятане на ВГП

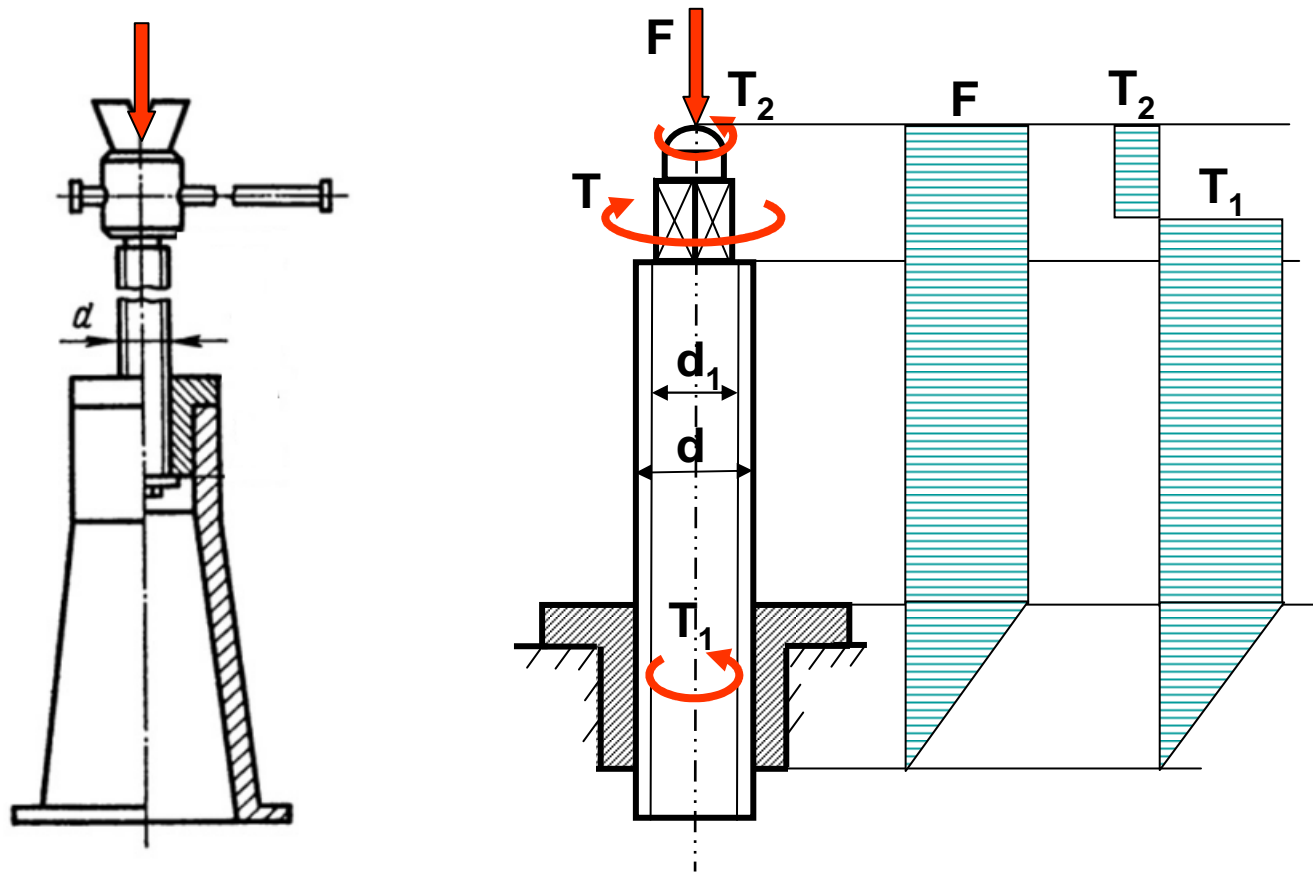

1. Подбор на резба на винта

2. Проверка на резбата на самозадържане

3. Еквивалентно напрежение във винтовото стебло

4. Проверка на стеблото на изкълчване - по “ ϕ ” метод

5. Определяне на броя на навивките на гайката

КПД на ВГП

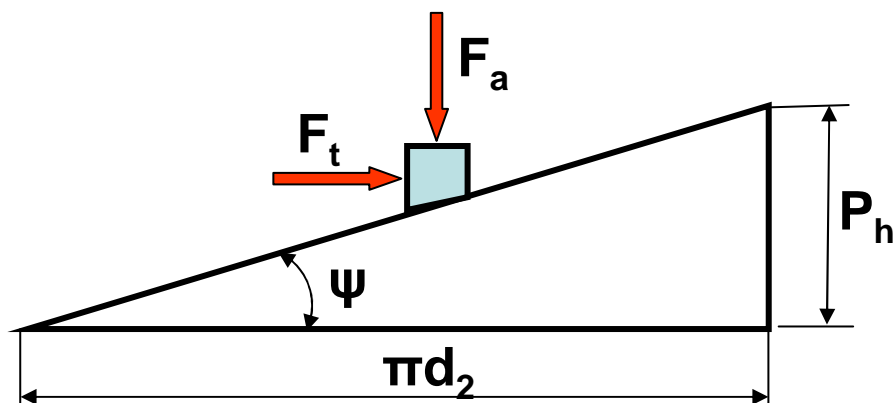

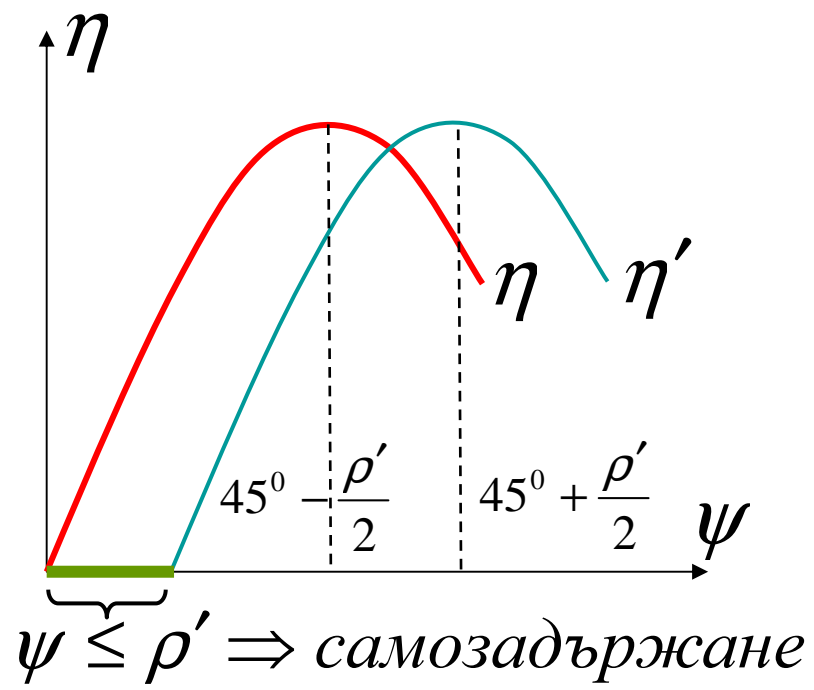

Въпрос № 22

**ВЕРИЖНИ ПРЕДАВКИ– ВИДОВЕ ВЕРИГИ И
ВЕРИЖНИ КОЛЕЛА. ГЕОМЕТРИЧНИ ПАРАМЕТРИ
И КИНЕМАТИЧНИ ЗАВИСИМОСТИ.
КРИТЕРИИ ЗА РАБОТОСПОСОБНОСТ**

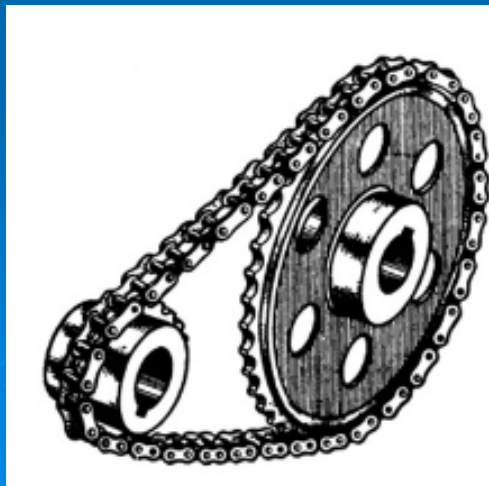

Видове вериги

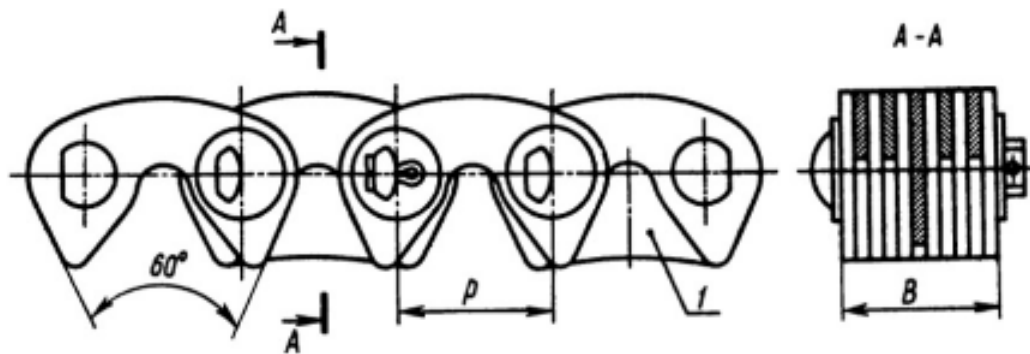
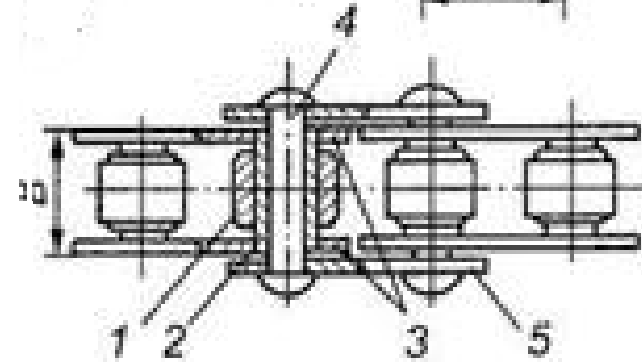
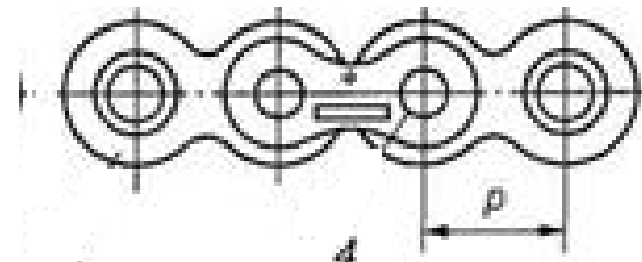
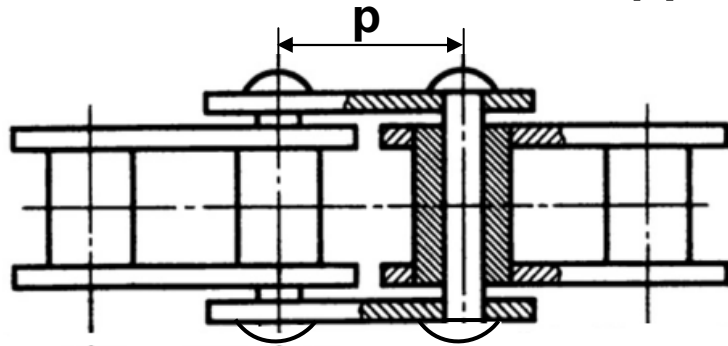

[Empty red-bordered box]

Материали

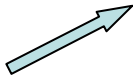

[Empty red-bordered box]

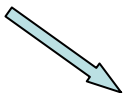

[Empty red-bordered box]

Верижни колела

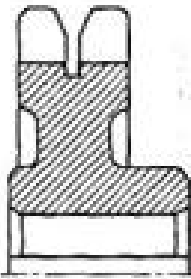
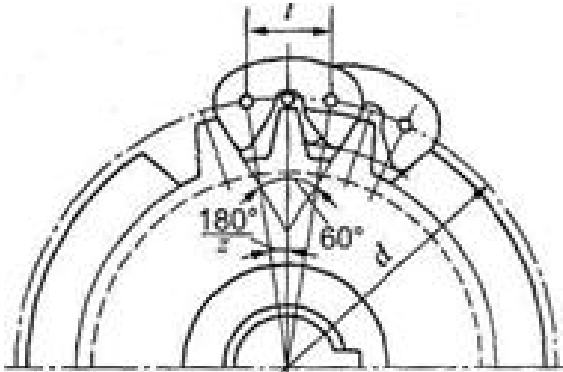
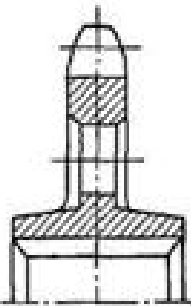
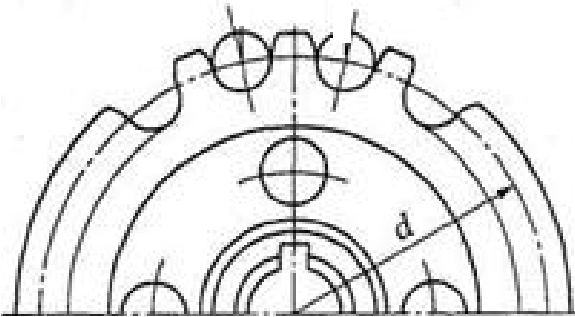

[Empty red-bordered box]

[Empty red-bordered box]

**Материали – стомана 15, 20, 40Х, 50,
пластмаса**

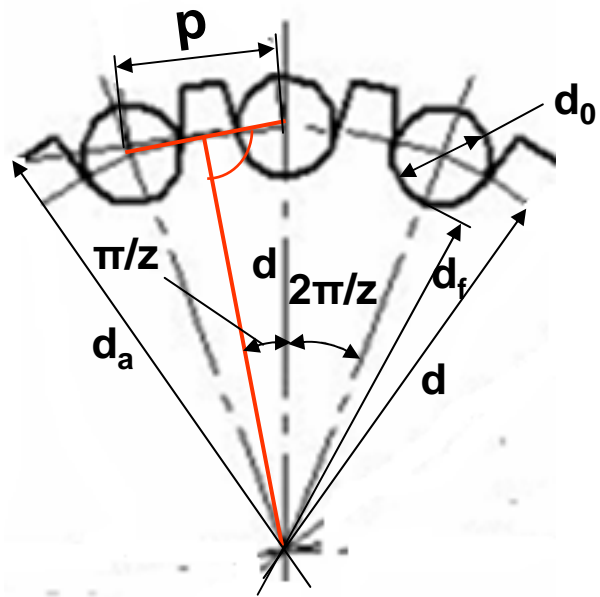

Геометрични параметри

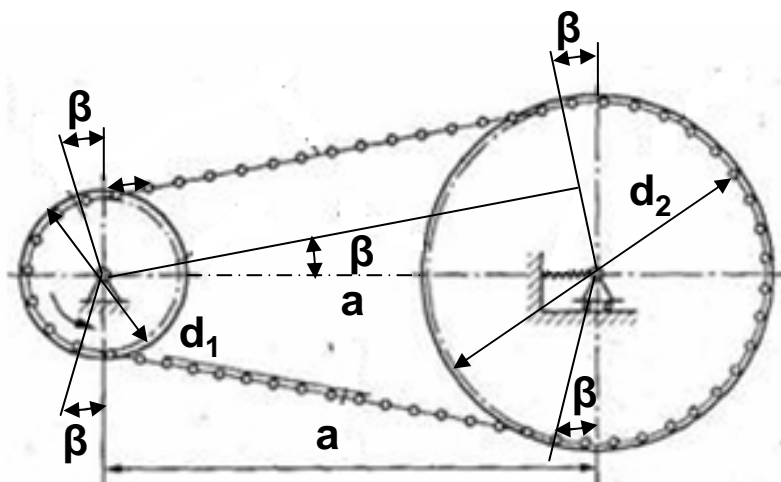

Брой на звената във веригата $W=L / p$

Ако положим в (1) :

$$\begin{cases} \sin \beta = \frac{d_2 - d_1}{2a} \approx \beta \\ \cos \beta \approx 1 \\ \pi d = pz \Rightarrow d = \frac{p}{\pi} z \end{cases}$$

$$W = \frac{L}{p} \approx \frac{2a}{p} + \frac{z_1 + z_2}{2} + \left(\frac{z_2 - z_1}{2\pi} \right)^2 \frac{p}{a}$$

Средно предавателно отношение :
(в рамките на един оборот на малкото колело)



Сили във верижната предавка

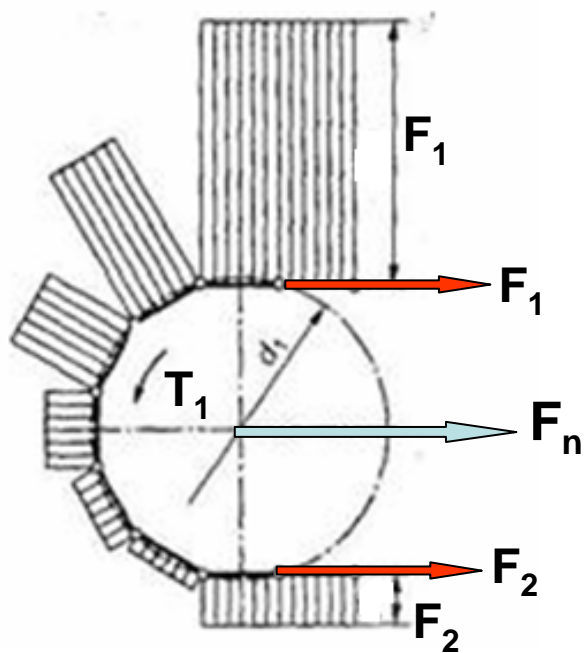

Напрежения в елементите на втулкова верига

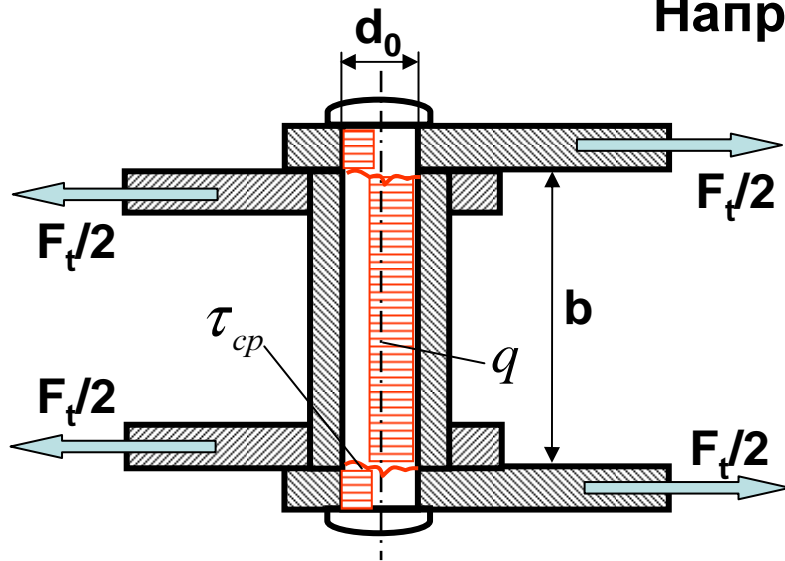

оси - срязване и смачкване
пластини – опън и смачкване
втулки - смачкване

$$[q] = (15 \div 30) \text{MPa} \quad A = d_0 b$$

K_E – коефициент на експлоатация, зависещ от: режима на натоварване, положението на предавката, начина на смазване, регулирането на опъването на веригата