



**IEEE Standard for  
Information technology—**

**Telecommunications and information  
exchange between systems—**

**Local and metropolitan area networks—**

**Specific requirements**

**Part 3: Carrier sense multiple access with  
Collision Detection (CSMA/CD) Access Method  
and Physical Layer Specifications**

---

**IEEE Computer Society**

Sponsored by the  
LAN/MAN Standards Committee

---

IEEE  
3 Park Avenue  
New York, NY 10016-5997, USA

26 December 2008

**IEEE Std 802.3™-2008**  
(Revision of IEEE Std 802.3-2005)

802.3<sup>TM</sup>



**IEEE Standard for Information technology—  
Telecommunications and information exchange between systems—  
Local and metropolitan area networks—  
Specific requirements**

**Part 3: Carrier Sense Multiple Access with  
Collision Detection (CSMA/CD) Access Method  
and Physical Layer Specifications**

Sponsor

**LAN/MAN Standards Committee  
of the  
IEEE Computer Society**

Approved 26 September 2008

**IEEE-SA Standards Board**

**Abstract:** Ethernet local area network operation is specified for selected speeds of operation from 1 Mb/s to 10 Gb/s using a common media access control (MAC) specification and management information base (MIB). The Carrier Sense Multiple Access with Collision Detection (CSMA/CD) MAC protocol specifies shared medium (half duplex) operation, as well as full duplex operation. Speed specific Media Independent Interfaces (MIIs) allow use of selected Physical Layer devices (PHY) for operation over coaxial, twisted pair or fiber optic cables. System considerations for multisegment shared access networks describe the use of Repeaters which are defined for operational speeds up to 1000 Mb/s. Local Area Network (LAN) operation is supported at all speeds. Other specified capabilities include: various PHY types for access networks, PHYs suitable for metropolitan area network applications, and the provision of power over selected twisted pair PHY types.

**Keywords:** 10BASE; 100BASE; 1000BASE; 10GBASE; 10 Gigabit Ethernet; attachment unit interface; AUI; Auto Negotiation; data processing; DTE Power via the MDI; EPON; Ethernet; Ethernet in the First Mile; Ethernet passive optical network; Fast Ethernet; Gigabit Ethernet; GMII; information exchange; local area network; management; medium dependent interface; media independent interface; MDI; MIB; MII; XGMII; PHY; physical coding sublayer; Physical Layer; physical medium attachment; PMA; Power over Ethernet; repeater; type field; VLAN TAG

---

The Institute of Electrical and Electronics Engineers, Inc.  
3 Park Avenue, New York, NY 10016-5997, USA

Copyright © 2008 by the Institute of Electrical and Electronics Engineers, Inc.  
All rights reserved. Published 26 December 2008. Printed in the United States of America.

IEEE and 802 are registered trademarks in the U.S. Patent & Trademark Office, owned by The Institute of Electrical and Electronics Engineers, Incorporated.

**Third Printing: 22 June 2010.** Correction on page 743 (subclause 31B3.2.6), corrigendum in Section Two of 31B.3.7 and 31B 4.6, and a correction to the subclause number (31B.3.3) is included in this printing.

PDF: ISBN 973-07381-5796-2 STD95819  
Print: ISBN 973-07381-5797-9 STDPD95819

*No part of this publication may be reproduced in any form, in an electronic retrieval system or otherwise, without the prior written permission of the publisher.*



**IEEE Standards** documents are developed within the IEEE Societies and the Standards Coordinating Committees of the IEEE Standards Association (IEEE-SA) Standards Board. The IEEE develops its standards through a consensus development process, approved by the American National Standards Institute, which brings together volunteers representing varied viewpoints and interests to achieve the final product. Volunteers are not necessarily members of the Institute and serve without compensation. While the IEEE administers the process and establishes rules to promote fairness in the consensus development process, the IEEE does not independently evaluate, test, or verify the accuracy of any of the information or the soundness of any judgments contained in its standards.

Use of an IEEE Standard is wholly voluntary. The IEEE disclaims liability for any personal injury, property or other damage, of any nature whatsoever, whether special, indirect, consequential, or compensatory, directly or indirectly resulting from the publication, use of, or reliance upon this, or any other IEEE Standard document.

The IEEE does not warrant or represent the accuracy or content of the material contained herein, and expressly disclaims any express or implied warranty, including any implied warranty of merchantability or fitness for a specific purpose, or that the use of the material contained herein is free from patent infringement. IEEE Standards documents are supplied “**AS IS.**”

The existence of an IEEE Standard does not imply that there are no other ways to produce, test, measure, purchase, market, or provide other goods and services related to the scope of the IEEE Standard. Furthermore, the viewpoint expressed at the time a standard is approved and issued is subject to change brought about through developments in the state of the art and comments received from users of the standard. Every IEEE Standard is subjected to review at least every five years for revision or reaffirmation. When a document is more than five years old and has not been reaffirmed, it is reasonable to conclude that its contents, although still of some value, do not wholly reflect the present state of the art. Users are cautioned to check to determine that they have the latest edition of any IEEE Standard.

In publishing and making this document available, the IEEE is not suggesting or rendering professional or other services for, or on behalf of, any person or entity. Nor is the IEEE undertaking to perform any duty owed by any other person or entity to another. Any person utilizing this, and any other IEEE Standards document, should rely upon his or her independent judgement in the exercise of reasonable care in any given circumstances or, as appropriate, seek the advice of a competent professional in determining the appropriateness of a given IEEE standard.

Interpretations: Occasionally questions may arise regarding the meaning of portions of standards as they relate to specific applications. When the need for interpretations is brought to the attention of IEEE, the Institute will initiate action to prepare appropriate responses. Since IEEE Standards represent a consensus of concerned interests, it is important to ensure that any interpretation has also received the concurrence of a balance of interests. For this reason, IEEE and the members of its societies and Standards Coordinating Committees are not able to provide an instant response to interpretation requests except in those cases where the matter has previously received formal consideration. A statement, written or oral, that is not processed in accordance with the IEEE-SA Standards Board Operations Manual shall not be considered the official position of IEEE or any of its committees and shall not be considered to be, nor be relied upon as, a formal interpretation of the IEEE. At lectures, symposia, seminars, or educational courses, an individual presenting information on IEEE standards shall make it clear that his or her views should be considered the personal views of that individual rather than the formal position, explanation, or interpretation of the IEEE.

Comments for revision of IEEE Standards are welcome from any interested party, regardless of membership affiliation with IEEE. Suggestions for changes in documents should be in the form of a proposed change of text, together with appropriate supporting comments. Comments on standards and requests for interpretations should be submitted to the following address:

Secretary, IEEE-SA Standards Board  
445 Hoes Lane  
Piscataway, NJ 08854  
USA

Authorization to photocopy portions of any individual standard for internal or personal use is granted by The Institute of Electrical and Electronics Engineers, Inc., provided that the appropriate fee is paid to Copyright Clearance Center. To arrange for payment of licensing fee, please contact Copyright Clearance Center, Customer Service, 222 Rosewood Drive, Danvers, MA 01923 USA; +1 978 750 8400. Permission to photocopy portions of any individual standard for educational classroom use can also be obtained through the Copyright Clearance Center.

## Introduction

This introduction is not part of IEEE Std 802.3-2008, IEEE Standard for Information technology—Telecommunications and information exchange between systems—Local and metropolitan area networks—Specific requirements, Part 3: CSMA/CD Access Method and Physical Layer Specifications.

IEEE Std 802.3™ was first published in 1985. Since the initial publication, many projects have added functionality or provided maintenance updates to the specifications and text included in the standard. Each IEEE 802.3 project/amendment is identified with a suffix (e.g., IEEE 802.3an™-2006). A historical listing of all projects that have added to or modified IEEE Std 802.3 follows as a part of this introductory material. The listing is in chronological order of project initiation and for each project describes: subject, clauses added (if any), approval dates, and committee officers.

The Media Access Control (MAC) protocol specified in IEEE Std 802.3 is Carrier Sense Multiple Access with Collision Detection (CSMA/CD). This MAC protocol was included in the experimental Ethernet developed at Xerox Palo Alto Research Center. While the experimental Ethernet had a 2.94 Mb/s data rate, IEEE Std 802.3-1985 specified operation at 10 Mb/s. Since 1985 new media options, new speeds of operation, and new capabilities have been added to IEEE Std 802.3.

Some of the major additions to IEEE Std 802.3 are identified in the marketplace with their project number. This is most common for projects adding higher speeds of operation or new protocols. For example, IEEE Std 802.3u™ added 100 Mb/s operation (also called Fast Ethernet), IEEE Std 802.3x™ specified full duplex operation and a flow control protocol, IEEE Std 802.3z™ added 1000 Mb/s operation (also called Gigabit Ethernet), IEEE Std 802.3ae™ added 10 Gb/s operation (also called 10 Gigabit Ethernet) and IEEE Std 802.3ah™ specified access network Ethernet (also called Ethernet in the First Mile). These major additions are all now included in and are superseded by IEEE Std 802.3-2008 and are not maintained as separate documents.

In parallel with the development of this revision, the specification of link aggregation was moved into a new standard, IEEE Std 802.1AX™-2008. With this publication, IEEE Std 802.3 is comprised of the following documents

### IEEE Std 802.3-2008

Section One—Includes Clause 1 through Clause 20 and Annex A through Annex H and Annex 4A. Section One includes the specifications for 10 Mb/s operation and the MAC, frame formats and service interfaces used for all speeds of operation.

Section Two—Includes Clause 21 through Clause 33 and Annex 22A through Annex 33E. Section Two includes management attributes for multiple protocols and speed of operation as well as specifications for providing power over twisted pair cabling for multiple operational speeds. It also includes general information on 100 Mb/s operation as well as most of the 100 Mb/s physical layer specifications.

Section Three—Includes Clause 34 through Clause 43 and Annex 36A through Annex 43C. Section Three includes general information on 1000 Mb/s operation as well as most of the 1000 Mb/s physical layer specifications.

Section Four—Includes Clause 44 through Clause 55 and Annex 44A through Annex 55B. Section Four includes general information on 10 Gb/s operation as well as most of the 10 Gb/s physical layer specifications.

Section Five—Includes Clause 56 through Clause 74 and Annex 57A through Annex 74A. Clause 56 through Clause 67 and associated annexes specify subscriber access physical layers and sublayers for

operation from 512 kb/s to 1000 Mb/s, and defines services and protocol elements that enable the exchange of IEEE Std 802.3 format frames between stations in a subscriber access network. Clause 68 specifies a 10 Gb/s physical layer specification. Clause 69 through Clause 74 and associated annexes specify Ethernet operation over electrical backplanes at speeds of 1000 Mb/s and 10 Gb/s.

IEEE Std 802.3 will continue to evolve. New Ethernet capabilities are anticipated to be added within the next few years as amendments to this standard.

## **Notice to users**

### **Laws and regulations**

Users of these documents should consult all applicable laws and regulations. Compliance with the provisions of this standard does not imply compliance to any applicable regulatory requirements. Implementers of the standard are responsible for observing or referring to the applicable regulatory requirements. IEEE does not, by the publication of its standards, intend to urge action that is not in compliance with applicable laws, and these documents may not be construed as doing so.

### **Copyrights**

This document is copyrighted by the IEEE. It is made available for a wide variety of both public and private uses. These include both use, by reference, in laws and regulations, and use in private self-regulation, standardization, and the promotion of engineering practices and methods. By making this document available for use and adoption by public authorities and private users, the IEEE does not waive any rights in copyright to this document.

### **Updating of IEEE documents**

Users of IEEE standards should be aware that these documents may be superseded at any time by the issuance of new editions or may be amended from time to time through the issuance of amendments, corrigenda, or errata. An official IEEE document at any point in time consists of the current edition of the document together with any amendments, corrigenda, or errata then in effect. In order to determine whether a given document is the current edition and whether it has been amended through the issuance of amendments, corrigenda, or errata, visit the IEEE Standards Association website at <http://ieeexplore.ieee.org/xpl/standards.jsp>, or contact the IEEE at the address listed previously.

For more information about the IEEE Standards Association or the IEEE standards development process, visit the IEEE-SA website at <http://standards.ieee.org>.

### **Errata**

Errata, if any, for this and all other standards can be accessed at the following URL: <http://standards.ieee.org/reading/ieee/updates/errata/index.html>. Users are encouraged to check this URL for errata periodically.

### **Interpretations**

Current interpretations can be accessed at the following URL: <http://standards.ieee.org/reading/ieee/interp/index.html>.

## Patents

Attention is called to the possibility that implementation of this amendment may require use of subject matter covered by patent rights. By publication of this amendment, no position is taken with respect to the existence or validity of any patent rights in connection therewith. The IEEE is not responsible for identifying Essential Patent Claims for which a license may be required, for conducting inquiries into the legal validity or scope of Patents Claims or determining whether any licensing terms or conditions provided in connection with submission of a Letter of Assurance, if any, or in any licensing agreements are reasonable or non-discriminatory. Users of this amendment are expressly advised that determination of the validity of any patent rights, and the risk of infringement of such rights, is entirely their own responsibility. Further information may be obtained from the IEEE Standards Association.

## Participants

The following individuals were officers of the IEEE 802.3 working group at the beginning of the working group ballot of this revision:

**Robert M. Grow**, *Working Group Chair*  
**David J. Law**, *Working Group Vice-Chair, IEEE 802.3ay Task Force Chair and Editor*  
**Wael William Diab**, *Working Group Secretary*  
**Steven B. Carlson**, *Working Group Executive Secretary*  
**Bradley Booth**, *Working Group Treasurer*

## Historical participants

The following individuals participated in the IEEE 802.3 working group during various stages of the standard's development. Since the initial publication, many IEEE standards have added functionality or provided updates to material included in this standard. Included is a historical list of participants who have dedicated their valuable time, energy, and knowledge to the creation of this material:

<b>IEEE Std 802.3 document</b>	<b>Date approved by IEEE and ANSI</b>	<b>Officers at the time of working group ballot</b>
IEEE Std 802.3-1985, Original 10 Mb/s standard, MAC, PLS, AUI, 10BASE5	23 June 1983 (IEEE) 31 December 1984 (ANSI)	<b>Donald C. Loughry</b> , <i>Working Group Chair</i>
IEEE Std 802.3a-1988 (Clause 10), 10 Mb/s MAU 10BASE2	15 November 1985 (IEEE) 28 December 1987 (ANSI)	<b>Donald C. Loughry</b> , <i>Working Group Chair</i> <b>Alan Flatman</b> , <i>Task Force Chair</i>
IEEE Std 802.3b-1985 (Clause 11), 10 Mb/s Broad-band MAU, 10BROAD36	19 September 1985 (IEEE) 28 February 1986 (ANSI)	<b>Donald C. Loughry</b> , <i>Working Group Chair</i> <b>Menachem Abraham</b> , <i>Task Force Chair</i>
IEEE Std 802.3c-1985 (9.1–9.8), 10 Mb/s Baseband Repeater	12 December 1985 (IEEE) 4 June 1986 (ANSI)	<b>Donald C. Loughry</b> , <i>Working Group Chair</i> <b>Geoffrey O. Thompson</b> , <i>Task Force Chair</i>
IEEE Std 802.3d-1987 (9.9), 10 Mb/s Fiber MAU, FOIRL	10 December 1987 (IEEE) 9 February 1989 (ANSI)	<b>Donald C. Loughry</b> , <i>Working Group Chair</i> <b>Steven Moustakas</b> , <i>Task Force Chair</i>
IEEE Std 802.3e-1987 (Clause 12), 1 Mb/s MAU and Hub 1BASE5	11 June 1987 (IEEE) 15 December 1987 (ANSI)	<b>Donald C. Loughry</b> , <i>Working Group Chair</i> <b>Robert Galin</b> , <i>Task Force Chair</i>
IEEE Std 802.3h-1990 (Clause 5), 10 Mb/s Layer Management, DTEs	28 September 1990 (IEEE) 11 March 1991 (ANSI)	<b>Donald C. Loughry</b> , <i>Working Group Chair</i> <b>Andy J. Luque</b> , <i>Task Force Chair</i>

<b>IEEE Std 802.3 document</b>	<b>Date approved by IEEE and ANSI</b>	<b>Officers at the time of working group ballot</b>
IEEE Std 802.3i-1990 (Clauses 13 and 14), 10 Mb/s UTP MAU, 10BASE-T	28 September 1990 (IEEE) 11 March 1991 (ANSI)	<b>Donald C. Loughry</b> , <i>Working Group Chair</i> <b>Patricia Thaler</b> , <i>Task Force Chair (initial)</i> <b>Richard Anderson</b> , <i>Task Force Chair (final)</i>
IEEE Std 802.3j-1993 (Clauses 15–18), 10 Mb/s Fiber MAUs 10BASE-FP, 10BASE-FB, and 10BASE-FL	15 September 1993 (IEEE) 15 March 1994 (ANSI)	<b>Patricia Thaler</b> , <i>Working Group Chair</i> <b>Keith Amundsen</b> , <i>Task Force Chair (initial)</i> <b>Frederick Scholl</b> , <i>Task Force Chair (final)</i> <b>Michael E. Lee</b> , <i>Technical Editor</i>
IEEE Std 802.3k-1993 (Clause 19), 10 Mb/s Layer Management, Repeaters	17 September 1992 (IEEE) 8 March 1993 (ANSI)	<b>Patricia Thaler</b> , <i>Working Group Chair</i> <b>Joseph S. Skorupa</b> , <i>Task Force Chair</i> <b>Geoffrey O. Thompson</b> , <i>Vice Chair and Editor</i>
IEEE Std 802.3l-1992 (14.10), 10 Mb/s PICS Proforma 10BASE-T MAU	17 September 1992 (IEEE) 23 February 1993 (ANSI)	<b>Patricia Thaler</b> , <i>Working Group Chair</i> <b>Mike Armstrong</b> , <i>Task Force Chair and Editor</i> <b>Paul Nikolich</b> , <i>Vice Chair</i> <b>William Randle</b> , <i>Editorial Coordinator</i>
IEEE Std 802.3m-1995, Maintenance 2	21 September 1995 (IEEE) 16 July 1996 (ANSI)	<b>Patricia Thaler</b> , <i>Working Group Chair</i> <b>Gary Robinson</b> , <i>Maintenance Chair</i>
IEEE Std 802.3n-1995, Maintenance 3	21 September 1995 (IEEE) 4 April 1996 (ANSI)	<b>Patricia Thaler</b> , <i>Working Group Chair</i> <b>Gary Robinson</b> , <i>Maintenance Chair</i>
IEEE Std 802.3p-1993 (Clause 20), Management, 10 Mb/s Integrated MAUs	17 June 1993 (IEEE) 4 January 1994 (ANSI)	<b>Patricia Thaler</b> , <i>Working Group Chair</i> <b>Joseph S. Skorupa</b> , <i>Task Force Chair</i> <b>Geoffrey O. Thompson</b> , <i>Vice Chair and Editor</i>
IEEE Std 802.3q-1993 (Clause 5), 10 Mb/s Layer Management, GDMO Format	17 June 1993 (IEEE) 4 January 1994 (ANSI)	<b>Patricia Thaler</b> , <i>Working Group Chair</i> <b>Joseph S. Skorupa</b> , <i>Task Force Chair</i> <b>Geoffrey O. Thompson</b> , <i>Vice Chair and Editor</i>
IEEE Std 802.3r-1996 (8.8), Type 10BASE5 Medium Attachment Unit PICS proforma	29 July 1996 (IEEE) 6 January 1997 (ANSI)	<b>Patricia Thaler</b> , <i>Working Group Chair</i> <b>Imre Juhász</b> , <i>Task Force Chair</i> <b>William Randle</b> , <i>Task Force Editor</i>
IEEE Std 802.3s-1995, Maintenance 4	21 September 1995 (IEEE) 8 April 1996 (ANSI)	<b>Geoffrey O. Thompson</b> , <i>Working Group Chair</i> <b>Gary Robinson</b> , <i>Maintenance Chair</i>
IEEE Std 802.3t-1995, 120 Ω informative annex to 10BASE-T	14 June 1995 (IEEE) 12 January 1996 (ANSI)	<b>Geoffrey O. Thompson</b> , <i>Working Group Chair</i> <b>Jacques Christ</b> , <i>Task Force Chair</i>
IEEE Std 802.3u-1995 (Clauses 21–30), Type 100BASE-T MAC parameters, Physical Layer, MAUs, and Repeater for 100 Mb/s Operation	14 June 1995 (IEEE) 4 April 1996 (ANSI)	<b>Geoffrey O. Thompson</b> , <i>Working Group Chair</i> <b>Peter Tarrant</b> , <i>Task Force Chair (Phase 1)</i> <b>Howard Frazier</b> , <i>Task Force Chair (Phase 2)</i> <b>Paul Sherer</b> , <i>Task Force Editor-in-Chief (Phase 1)</i> <b>Howard Johnson</b> , <i>Task Force Editor-in-Chief (Phase 2)</i> <b>Colin Mick</b> , <i>Task Force Comment Editor</i>
IEEE Std 802.3v-1995, 150 Ω informative annex to 10BASE-T	12 December 1995 (IEEE) 16 July 1996 (ANSI)	<b>Geoffrey O. Thompson</b> , <i>Working Group Chair</i> <b>Larry Nicholson</b> , <i>Task Force Chair</i>
IEEE Std 802.3x-1997 and IEEE Std 802.3y-1997 (Revisions to IEEE Std 802.3, Clauses 31 and 32), Full Duplex Operation and Type 100BASE-T2	20 March 1997 (IEEE) 5 September 1997 (ANSI)	<b>Geoffrey O. Thompson</b> , <i>Working Group Chair</i> <b>David J. Law</b> , <i>Working Group Vice Chair</i> <b>Rich Seifert</b> , <i>Task Force Chair and Editor (802.3x)</i> <b>J. Scott Carter</b> , <i>Task Force Chair (802.3y)</i> <b>Colin Mick</b> , <i>Task Force Editor (802.3y)</i>
IEEE Std 802.3z-1998 (Clauses 34–39, 41–42), Type 1000BASE-X MAC Parameters, Physical Layer, Repeater, and Management Parameters for 1000 Mb/s Operation	25 June 1998 (IEEE)	<b>Geoffrey O. Thompson</b> , <i>Working Group Chair</i> <b>David J. Law</b> , <i>Working Group Vice Chair</i> <b>Howard M. Frazier, Jr.</b> , <i>Task Force Chair</i> <b>Howard W. Johnson</b> , <i>Task Force Editor</i>
IEEE Std 802.3aa-1998, Maintenance 5	25 June 1998 (IEEE)	<b>Geoffrey O. Thompson</b> , <i>Working Group Chair</i> <b>Colin Mick</b> , <i>Task Force Editor</i>

<b>IEEE Std 802.3 document</b>	<b>Date approved by IEEE and ANSI</b>	<b>Officers at the time of working group ballot</b>
IEEE Std 802.3ab-1999 (Clause 40), Physical Layer Parameters and Specifications for 1000 Mb/s Operation Over 4 Pair of Category 5 Balanced Copper Cabling, Type 1000BASE-T	26 June 1999 (IEEE)	<b>Geoffrey O. Thompson</b> , <i>Working Group Chair</i> <b>David J. Law</b> , <i>Working Group Vice Chair</i> <b>Robert M. Grow</b> , <i>Working Group Secretary</i> <b>George Eisler</b> , <i>Task Force Chair</i> <b>Colin Mick</b> , <i>Task Force Editor</i>
IEEE Std 802.3ac-1998, Frame Extensions for Virtual Bridged Local Area Network (VLAN) Tagging on IEEE 802.3 Networks	16 September 1998 (IEEE)	<b>Geoffrey O. Thompson</b> , <i>Working Group Chair</i> <b>David J. Law</b> , <i>Working Group Vice Chair</i> <b>Andy J. Luque</b> , <i>Working Group Secretary</i> <b>Ian Crayford</b> , <i>Task Force Chair</i> <b>Rich Seifert</b> , <i>Task Force Editor</i>
IEEE Std 802.3ad-2000 (Clause 43), Aggregation of Multiple Link Segments	30 March 2000 (IEEE)	<b>Geoffrey O. Thompson</b> , <i>Working Group Chair</i> <b>David J. Law</b> , <i>Working Group Vice Chair</i> <b>Robert M. Grow</b> , <i>Working Group Secretary</i> <b>Steven Haddock</b> , <i>Task Force Chair</i> <b>Tony Jeffree</b> , <i>Task Force Co-Editor</i> <b>Rich Seifert</b> , <i>Task Force Co-Editor</i>
IEEE Std 802.3-2002 (IEEE 802.3ag, Maintenance 6, Revision of the base), Carrier Sense Multiple Access with Collision Detection (CSMA/CD) access method and physical layer specifications	14 January 2002 (IEEE)	<b>Geoffrey O. Thompson</b> , <i>Working Group Chair</i> <b>David J. Law</b> , <i>Working Group Vice Chair</i> <b>Robert M. Grow</b> , <i>Working Group Secretary</i>
IEEE Std 802.3ae-2002, (Clauses 44–53) Media Access Control (MAC) Parameters, Physical Layers, and Management Parameters for 10 Gb/s Operation	13 June 2002 (IEEE)	<b>Geoffrey O. Thompson</b> , <i>Working Group Chair</i> <b>David J. Law</b> , <i>Working Group Vice Chair</i> <b>Robert M. Grow</b> , <i>Working Group Secretary</i> <b>R. Jonathan Thatcher</b> , <i>Task Force Chair</i> <b>Stephen Haddock</b> , <i>Task Force Vice Chair</i> <b>Bradley J. Booth</b> , <i>Task Force Editor</i> <b>Lacreshia Laningham</b> , <i>Task Force Assistant Editor</i> <b>Benjamin Brown</b> , <i>Logic Track Chair</i> <b>Walter Thirion</b> , <i>Optical Track Chair</i>
IEEE Std 802.3af-2003, (Clause 33) Data Terminal Equipment (DTE) Power via Media Dependent Interface (MDI)	12 June 2003 (IEEE)	<b>Geoffrey O. Thompson</b> , <i>Working Group Chair (Phase 1)</i> <b>Robert M. Grow</b> , <i>Working Group Chair (Phase 2)</i> <b>David J. Law</b> , <i>Working Group Vice Chair</i> <b>Robert M. Grow</b> , <i>Working Group Secretary (Phase 1)</i> <b>Steven B. Carlson</b> , <i>Working Group Secretary (Phase 2)</i> <b>Steven B. Carlson</b> , <i>Task Force Chair</i> <b>Michael S. McCormack</b> , <i>Task Force Editor (Phase 1)</i> <b>John J. Jetzt</b> , <i>Task Force Editor (Phase 2)</i> <b>Chad M. Jones</b> , <i>Task Force Comment Editor</i>
IEEE Std 802.3ah-2004, Media Access Control Parameters, Physical Layers, and Management Parameters for Subscriber Access Networks	6 April 2005 (IEEE)	<b>Robert M. Grow</b> , <i>Working Group Chair</i> <b>David J. Law</b> , <i>Working Group Vice Chair</i> <b>Steven B. Carlson</b> , <i>Working Group Secretary</i> <b>Howard Frazier</b> , <i>Task Force Chair</i> <b>Wael W. Diab</b> , <i>Task Force Editor-in-Chief</i> <b>Hugh Barrass</b> , <i>Task Force Vice-Chair</i> <b>Scott Simon</b> , <i>Task Force Recording Secretary</i> <b>Behrooz Rezvani</b> , <i>Task Force Executive Secretary</i>
IEEE Std 802.3aj-2003, Maintenance 7	11 September 2003 (IEEE)	<b>Robert M. Grow</b> , <i>Working Group Chair</i> <b>David J. Law</b> , <i>Working Group Vice Chair, Task Force Chair</i> <b>Steven B. Carlson</b> , <i>Working Group Secretary</i> <b>Catherine K. N. Berger</b> , <i>Task Force Editor</i>
IEEE Std 802.3ak-2004, Physical Layer and Management Parameters for 10Gb/s Operation, Type 10GBASE-CX4	9 February 2004 (IEEE)	<b>Robert M. Grow</b> , <i>Working Group Chair</i> <b>David J. Law</b> , <i>Working Group Vice Chair</i> <b>Steven B. Carlson</b> , <i>Working Group Secretary</i> <b>Daniel J. Dove</b> , <i>Task Force Chair</i> <b>Howard A. Baumer</b> , <i>Task Force Editor</i>

<b>IEEE Std 802.3 document</b>	<b>Date approved by IEEE and ANSI</b>	<b>Officers at the time of working group ballot</b>
IEEE Std 802.3-2005 (IEEE 802.3REVam, Revision of the base). Carrier Sense Multiple Access with Collision Detection (CSMA/CD) access method and physical layer specifications	9 June 2005 (IEEE)	<b>Robert M. Grow</b> , <i>Working Group Chair</i> <b>David J. Law</b> , <i>Working Group Vice Chair</i> <b>Wael W. Diab</b> , <i>Working Group Vice Chair</i> <b>Steven B. Carlson</b> , <i>Working Group Executive Secretary</i> <b>Piers Dawe</b> , <i>Review Editor</i>
IEEE Std 802.3an-2006, Physical Layer and Management Parameter for 10 Gb/s Operation, Type 10GBASE-T	8 June 2006 (IEEE)	<b>Robert M. Grow</b> , <i>Working Group Chair</i> <b>David J. Law</b> , <i>Working Group Vice Chair</i> <b>Wael William Diab</b> , <i>Working Group Secretary</i> <b>Steven B. Carlson</b> , <i>Working Group Executive Secretary</i> <b>Bradley Booth</b> , <i>Task Force Chair</i> <b>Sanjay Kasturia</b> , <i>Task Force Editor-in Chief</i> <b>George Eisler</b> , <i>Task Force Recording Secretary</i>
IEEE Std 802.3ap-2007, Ethernet Operation over Electrical Backplanes	22 March 2007(IEEE)	<b>Robert M. Grow</b> , <i>Working Group Chair</i> <b>David J. Law</b> , <i>Working Group Vice-Chair</i> <b>Wael W. Diab</b> , <i>Working Group Secretary</i> <b>Steven B. Carlson</b> , <i>Working Group Executive Secretary</i> <b>Bradley Booth</b> , <i>Working Group Treasurer</i> <b>Adam Healey</b> , <i>Task Force Chair</i> <b>John D'Ambrosia</b> , <i>Task Force Secretary</i> <b>Schelto vanDoorn</b> , <i>Task Force Editor-in-Chief (Phase 1)</i> <b>Ilango S. Ganga</b> , <i>Task Force Editor-in-Chief (Phase 2)</i>
IEEE Std 802.3aq-2006, Physical Layer and Management Parameters for 10 Gb/s Operation, Type 10GBASE-LRM	15 September 2006 (IEEE)	<b>Robert M. Grow</b> , <i>Working Group Chair</i> <b>David J. Law</b> , <i>Working Group Vice Chair</i> <b>Wael William Diab</b> , <i>Working Group Secretary</i> <b>Steven B. Carlson</b> , <i>Working Group Executive Secretary</i> <b>David G. Cunningham</b> , <i>Task Force Chair</i> <b>Nick Weiner</b> , <i>Task Force Editor</i> <b>Piers Dawe</b> , <i>Task Force Contributing Editor</i>
IEEE Std 802.3as-2006, Frame format extensions	15 September 2006 (IEEE)	<b>Robert M. Grow</b> , <i>Working Group Chair</i> <b>David J. Law</b> , <i>Working Group Vice Chair</i> <b>Wael William Diab</b> , <i>Working Group Secretary</i> <b>Steven B. Carlson</b> , <i>Working Group Executive Secretary</i> <b>Kevin Q Daines</b> , <i>Task Force Chair</i> <b>Glenn W. Parsons</b> , <i>Task Force Editor</i>
IEEE Std 802.3-2005/Cor 1-2006 (IEEE 802.3au), DTE Power via MDI Isolation corrigendum	8 June 2006 (IEEE)	<b>Robert M. Grow</b> , <i>Working Group Chair</i> <b>David J. Law</b> , <i>Working Group Vice Chair, Task Force Editor</i> <b>Wael W. Diab</b> , <i>Working Group Secretary</i> <b>Steven B. Carlson</b> , <i>Working Group Executive Secretary</i>
IEEE Std 802.3-2005/Cor 2-2007 (IEEE 802.3aw), 10GBASE-T corrigendum	7 June 2007 (IEEE)	<b>Robert M. Grow</b> , <i>Working Group Chair</i> <b>David J. Law</b> , <i>Working Group Vice Chair, Task Force Editor</i> <b>Wael W. Diab</b> , <i>Working Group Secretary</i> <b>Steven B. Carlson</b> , <i>Working Group Executive Secretary</i> <b>Bradley Booth</b> , <i>Working Group Treasurer</i>

Ali Abaye	Chet Babla	Robert F. Bridge	David Chin
Fazal Abbas	Gerard E. Bachand	Vince Bridgers	Hon Wah Chin
John S. Abbott	Guna Bala	Dave Brier	Jae hun Cho
Hamlet Abedmamoore	R. V. Balakrishnam	Andrew Brierley-Green	Francis Choi
Joe Ablner	Andy Baldman	Rhett Brikovskis	Rahul Chopra
Menachem Abraham	Keith Balmer	Charles Brill	Jacky Chow
Shadi AbuGhazaleh	Mogens Cash Balsby	Robert D. Brink	Kuen Chow
Martin Adams	Bruce Bandali	Rick Brooks	Henry Choy
Luc Adriaennsens	Majid Barazande-Pour	Benjamin Brown	Chris Christ
Don Aelmore	Ian Barker	Daniel J. Brown	Jacques Christ
Puneet Agarwal	Eyal Barnea	Dave Brown	George Chu
Oscar Agazzi	Hugh Barrass	Jack Brown	Yue-Der Chzh
John R. Agee	Bob Barrett	Kevin Brown	Albert Claessen
Nand Aggarwal	Meir Bartur	Matt Brown	Guss Claessen
Paul Ahrens	Yoram Barzilai	Suzy Brown	G. J. Clancy
Vish Akella	Howard Baumer	Phillip Brownlee	Brice Clark
Reza Alavi	Denis Beaudoin	Brian Brunn	Susan Roden Clarke
Alan Albrecht	Michaël Beck	Robert Brunner	George Claseman
Keith Albright	Edward Beili	Steve F. Buck	Terry Cobb
Don Alderrou	Alexei Beliaev	Lisa Buckman	Michael Coden
Jan Alexander	William Belknap	Juan Bulnes	Kelly B. Coffey
Thomas Alexander	Randy J. Below	Bill Bunch	Larry Cohen
Abe Ali	Vincent Bemmell	James Burgess	Doug Coleman
Brad Allen	Mike Bennett	Scott Burton	Régis Colla
David Allen	Richard Bennett	Robert A. Busse	Kevin Cone
John Allen	Miles Benson	Thomas T. Butler	Herb Congdon
Arne Alping	Sidney Berglund	Roy Bynum	Patrick Conlon
Michael Altman	Ernest E. Bergmann	Ed Cady	Robert Conte
Karen Amavisca	April Bergstrom	Luca Cafiero	Charles I Cook
Khaled Amer	David J. Berman	John Cagle	Ronald J. Cooper
Nitish Amin	Roberto Bertoldi	Jeffrey C. Cain	Stephen Cooper
Keith Amundsen	John L. Bestel	Donald Caldwell	Neil Coote
Ole Christian Andersen	Dave Bethune	Richard Cam	Edward Cornejo
Arlan J. Anderson	Vipul Bhatt	Bob Campbell	Ronald Crane
Eric Anderson	Sudeep Bhoja	Peter Campbell	George Cravens
Paul Anderson	Harmeet Bhugra	Robert R. Campbell	Ian Crayford
Richard Anderson	James Binder	Luigi Canavese	John Creigh
Stephen D. Anderson	Larry Birenbaum	James T. Carlo	J. Francois Crepin
Stephen J. Anderson	Jeff E. Bisberg	Steven B. Carlson	Bill Cronin
Tony Anderson	Michel Bohbot	Dan Carnine	Peter Cross
Ralph Andersson	Mark Bohrer	J. Scott Carter	Richard Cross
Jack S. Andresen	Jean-Michel Bonnamy	Andrew Castellano	Brian Cruikshank
Ekkehard Antz	Bradley J. Booth	Ron Cates	David Cullerot
Ken-ichi Arai	Paul Booth	Jeffrey D. Catlin	Chris Cullin
Bert Armijo	Paul Bottorff	David Chalupsky	David G. Cunningham
Mike Armstrong	Thomas J. Boucino	Edward Chang	Joe Curcio
Susie Armstrong	Samuel Bourche	Edward G. Chang	Robert A. Curtis
Brian Arnold	David Bourque	Edward S. Chang	Simon Cushin
Lewis B. Aronson	Gary Bourque	Justin Chang	Dariush Dabiri
Simcha Aronson	Sidney Bouzaglo	Kiwon Chang	Robert Dahlgren
Phil L. Arst	Kirk Bovill	Luke Chang	Saleem Dahmouh
Doug Artman	John Bowerman	Samuel Chang	Bernard Daines
Jean-Pierre Astorg	Richard Bowers	Howard Charney	Kevin Q Daines
Mehran Atae	Peter Bradshaw	Xiaopeng Chen	John Dallesasse
Ilan Atias	Al Braga	Zinan (Nan) Chen	John D'Ambrosia
Steve Augusta	Richard Brand	Linda Cheng	Nabil Damouny
Phil Auld	Ralf-Peter Braun	Kok-Wui Cheong	Rupert S. Dance
Kameron Azadet	Richard S. Brehove	Giovanni Cherubini	Mark Darby
Joseph N. Babanezhad	Steve Brewer	Albert Chiang	Yair Darshan



Peter Dartnell	Dean Edwards	Mel Gable	Benny Hanigal
Subrata Datta	Frank J Effenberger	Robert D Gaglianello	G. Y. Hanna
John Davidson	John Egan	Justin Gaither	Chris Hansen
David Davies	Herman Eiliya	Robert Galin	Johannes Hansen
Edward Davis	George Eisler	Sharad Gandhi	Mogens Hansen
Peter Dawe	Martin Elhøj	Tom Gandy	Del Hanson
Piers Dawe	Kevin M. Elliff	Ilango S. Ganga	Onn Haran
John De Andrea	Michael Elswick	Robin Gangopadhya	Hacene Hariti
Kathryn de Graaf	Paul "Skip" Ely	Xiao Ming Gao	Guy Harkins
Gerald de Grace	Richard Ely	Clete Gardenhour	Milton C. Harper
Michael de la Garrigue	Kent English	Geoffrey M. Garner	Doug Harshbarger
Moshe De Leon	Gregory Ennis	Denton Gentry	G. R. Hartley
Bernard O. Debbasch	Gianfranco Enrico	John George	Lloyd Hasley
Michael deBie	Brian S. Ensign	Floyd H. Gerhardt	Marwan Hassoun
Tom Debiec	Norman Erbacher	Keith Gerhardt	Mehdi Hatamian
John DeCramer	Tooraj Esmailian	Mark Gerhold	W. B. Hatfield
Joel Dedrick	Nick Esser	Ali Ghiasi	Tom Hatley
Steve Deffley	Daniel Essig	Sajol Ghoshal	Stephen Haughey
Dave Delaney	Judith Estrin	Giorgio Giaretta	Haw Ming Haung
Moshe De-Leon	Jim Everitt	Pat Gilliland	Kirk Hayden
Ralph DeMent	Steve Evitts	George Ginis	Claude Hayek
Joe DeNicholas	John F. Ewen	Joel Goergen	Carl G. Hayssen
Tazio M. DeNicolo	Richard Fabbri	Adi Golbert	Asif Hazarika
Sanjay Desai	Siavash Fallahi	Glenn Golden	Adam Healey
Peter Desaulniers	Sabina Fanfoni	Moty Goldis	Gaby Hecht
Mark Devon	Rebecca Farley	Matthew Goldman	Jim Heckroth
Sanjay Dhawan	Eldon Feist	Timothy D. Goodman	Chris Heegard
Wael William Diab	Daniel Feldman	Steve Goody	Gopal Hegde
Erik Dickens	Feifei (Felix) Feng	Rich Graham	Wolfgang Heidasch
Chris DiMinico	Severn Ferdun	Eric B. Grann	Ronen Heldman
Thomas J. Dineen	Jean-Loup Ferrant	Tom Grasmehr	Ariel Hendel
Sean Dingman	Mark Feuerstraeter	C. Thomas Gray	Itzik Hendel
Thuyen Dinh	Jens Fiedler	Martin Green	Susan Hennenfent
Hans Peter Dittler	Dave Fifield	Jonathan E. Greenlaw	Ken Herrity
Hamish Dobson	Norival Figueira	Bryan Gregory	James H. Hesson
David W. Dolfi	Juan Figueroa	Richard Grenier	John Hickey
Mark Donhowe	Robert G. Finch	Edward Grivna	Chip Hicks
Hank (H. N.) Dorris	Norman Finn	Robert M. Grow	Tetsuya Higuchi
Dan Dove	Farzin Firoozmand	Robert Gudz	Olli-Pekka Hiironen
James Doyle	David Fischer	Andreas Gulle	John Hill
Daniel S. Draper	John Fitzgerald	Karunakar Gulukota	Tricia Hill
Scott Dredge	Alan Flatman	Ajay Gummalla	Sammy Hindi
Brian Drever	Steve Flickinger	Richard Gumpertz	William Hingston
Steve Dreyer	Christian G. Folting	Bin Guo	Henry Hinrichs
John Dring	Brian Ford	Sandeep Gupta	David Hinzal
Mike Dudek	Richard Fransen	Sudhir Gupta	Ryan Hirth
Richard Dugan	Roger Fraser	Tanmay Gupta	Charlie Hochstedler
Raymond S. Duley	Howard Frazier	Jonas Gustafsson	Charles Hoffner
Joseph E. Dupuis	Ladd Freitag	Russ Gyurek	Jay Hoge
Marc R. Dupuis	Ken Friedenbach	Steven Haas	Bryan Hoover
David Dwelley	Scott Fritz	Michael Hackert	Gregory Hopkins
J. Craig Easley	Krister Frojdh	Tariq Haddad	Steven E. Horowitz
Paul Eastman	Richard Froke	Stephen Haddock	Michael Horvat
Jeff Ebeling	Ingrid Fromm	Atikem Haile-Mariam	Henry Hsiaw
Peter Ecclesine	Richard Frosch	Sharam Hakimi	Jacob Hsu
Edward J. Eckert	Judy Fuess	Clive Hallatt	Fred Huang
Clay Eddings	Yukihiro Fujimoto	Farid Hamidy	Chuck Hudson
Phil Edholm	Atsuhisa Fukuoka	Kevin Hamilton	Todd Hudson
Tom Edsall	Darrell Furlong	Bernie Hammond	Michael Hughes

Walter K. Hurwitz	Hadriel Kaplan	George Kubovcik	Avinoam Levy
Thong Huynh	Rainer Kaps	Pankaj Kumar	Van Lewing
David W. Hyer	Roger Karam	Ted Kummert	Richard Lewis
Haruhiko Ichino	Jaime Kardontchik	Aniruddha Kundu	Sam Liang
Osamu Ishida	Yuji Kasai	David Kung	William P. Lidinsky
Steve Jackson	Allen Kasey	Jeffrey Kuo	Seyoun Lim
Krista S Jacobsen	Sanjay Kasturia	David Kurcharczyk	John O. Limb
Michael R. Jacobson	Toyoyuki Kato	Christopher Kurker	Chan-De Lin
Mike Jacobson	Harold W. Katz	Hidetsune Kurokawa	George Lin
Ajit Jadeja	Dave Kaufman	Gerard Kuyt	Ray Lin
John M. Jaeger	Sumesh Kaul	Alan Kwentus	Yoseph L. Linde
Brent Jaffa	Kevin Kayser	Lee LaBarre	Wayne Lindquist
Raj Jain	Paul Kellam	Adel Henry Labib	Thomas A. Lindsay
David V. James	N. Patrick Kelly	Richard LaCerte	Laurie Lindsey
Eric Jang	Joe Kennedy	Hans Lackner	Jr., Robert Lingle
Woo-Hyuk Jang	John J. Kenny	Gadi Lahat	Cathy Liu
Stephen Janshego	Scott Kesler	Lawrence J. Lamers	Chang-Chi Liu
Jonathan Jedwab	Dawson Kesling	Erik Lander	Fengkun Liu
Tony Jeffree	Lior Khermosh	D. Matthew Landry	William D. Livingston
George D. Jelatis	Tuan Khuu	William Lane	Martin Lobel
Ernie Jensen	Gary Kidwell	Gordon Langlands	Terry Lockyer
John Jetzt	Bob Kilgore	Daun Langston	Hugh Logan
Jack L. Jewell	Chan Kim	Jeff Lapak	Larry Lomelino
Wenbin Jiang	Dae Young Kim	Ed Lare	Leland Long
Ni Jie	Jin H. Kim	Loren Larsen	Sherry J. Lorei
Andrew C. Jimenez	Su-Hyung Kim	Donald C. Larson	Jahan Lotfi
Robert Jin	Yong Kim	Ryan Latchman	Dennis Lou
Clarence Joh	Marc Kimpe	Tony Lau	Don Loughry
Michael D. Johas Teener	John Kincaid	Tony Lauck	Bob Love
Richard John	Bill Kind	Bruce LaVigne	Rick Loveless
Donald C. Johnson	Jonathan P. King	David J. Law	Ken Lu
Howard Johnson	Neal King	Eric Lawrence	Fred A. Lucas
Mize Johnson	Paul Kish	Michael Lawton	James A. Lucas
Scott Johnson	Tadayoshi Kitayama	John Laynor	Meilissa R. Lum
Cristopher Jolly	Richard Knight	Yannick Le Goff	Andy J. Luque
Chad Jones	Hiroshi Kobayashi	My Le	Jeffrey Lynch
Nick Jones	Henricus Koeman	Quang Le	Mark Lynn
William W. Jones	David J. Koenen	Michael Lebar	Eric R. Lynskey
Ulf Jonsson	Christine Koenig	Greg LeCheminant	Ian Lyon
Seong-Soon Joo	David E. Kohl	Changoo Lee	Henning Lysdal
Anthony Jordan	Srinivas Kola	Chun-Tsung Lee	Brian MacLeod
Thomas K. Jørgensen	Paul F. Kolesar	Eugene Lee	Kenneth MacLeod
Juan Jover	Steven Koller	Fu-Ho Lee	Sam Madani
Imre Juhász	Kishan Rao Konda	Hyeong Ho Lee	Randall Magliozzi
Jason Julyan	David Kooistra	Jack Lee	Ariel Maislos
Kwi-Yung Jung	Derek Koonce	Michael Lee	Rabih Makarem
Dieter W. Junkers	Paul Kopera	Wesley Lee	Daniel Maltbie
Paul Jury	Leonid Koshevoy	Ying Lee	Jim Mangin
David Kabal	Josef Kosilek	Vincent Lefebvre	Bob Marchetti
Jayant Kadambi	Donald E. Kotas	Richard Lefkowitz	Luciano Marchitto
Vic Kairis	William F. Kous	Amir Lehr	Arthur Marris
Shinkyō Kaku	Tetsu Koyama	Brian E. Lemoff	Charles Marsh
Omer Kal	Josef Kozilek	Richard Lena	Robert Marshall
Mohan Kalkunte	Glen Koziuk	Lisa Leo	Robert A. Marsland
Amrit Kalla	Glen Kramer	Robert H. Leonowich	Arlen Martin
Joel S. Kalman	Daniel Krent	Michael Lerer	David W. Martin
Matt Kaltenbach	Subi Krishnamurthy	Warayot Lertniphonphun	Jeff Martin
Puru Kamat	Lars Paul Krolner	Amir Leshem	Koichiro Mashiko
Ron Kao	Simon Kropveld	Tommy Leung	Scott Mason

Thomas Mathey	Robert Mortonson	Philip Orlik	Scott R. Powell
Ziad Albert Matni	Simon Moseley	Aidan O'Rourke	Gideon Prat
Hideyuki Matsuo	Jack Moses	Michael O'Toole	Bernd Prediger
Bob Matthys	Steven Moustakas	Tony O'Toole	Robert S. Printis
Bret A. Matz	Wayne A. Mueller	George Oughton	John Proffitt
Bob Mayer	Robert Muir	Pat Overs	Steve Pryor
Joseph Mazor	Shankar Mukherjee	Kazuyuki Ozawa	Haoli Qian
David S. McCallum	Shimon Muller	Paul Pace	William Quackenbush
Kent McCammon	Carrie Munson	Robert R. Pace	Tomas J. Quigley
Philip L. McCarron	Ken Murakami	Charles Palanzo	Jim Quilici
Frank McCarthy	Denis Murphy	Tom Palkert	Patrick W. Quinn
Brett McClellan	Thomas Murphy	Don Pannell	John Quirk
Kelly McClellan	Brian Murray	Bill Panos	Rick Rabinovich
Mike McConnell	Narayan Murthy	Gabriel D Papandrea	Jerry K. Radcliffe
John McCool	Samba Murthy	Keshab K. Parhi	Ted Rado
Michael S. McCormack	Robert Musk	Jim Parker	Sreen Raghavan
Gary McCoy	Jim Muth	Elwood T. Parsons	Jurgen Rahn
Andy McDonald	Yaron Nachman	Glenn W. Parsons	Mohammad Rajabzadeh
Jerry McDowell	Gerard Nadeau	Joel Paslaski	Shlomo Rakib
Chris McGugan	Ken Naganuma	Jerry Pate	Naresh Raman
Keith McKechnie	Hari Naidu	Bhavesht Patel	Brian Ramelson
Donna McMaster	Wendell Nakamine	Dipak M. Patel	Brian J. Ramsey
Tim McShane	Karl Nakamura	Piyush Patel	William Randle
James D. McVey	Nersi Nazari	Sandeep Patel	Sailesh K. Rao
Grahame Measor	W. P. Neblett	Martin Patoka	Jennifer G. Rasimas
Mukesh Mehta	Erwan Nedellec	Aidan Paul	Dan Rausch
Richard Y. Mei	Darcy Nelson	Prasun K. Paul	Peter Rautenberg
Vince Melendy	James Nelson	Alex Pavlovsky	Eric Rawson
Richard Mellitz	Kristian Nelson	John Payne	Robert Reed
Avraham Menachem	Trung Nguyen	Tony Peatfield	Ivan Reede
Mark Merrill	Thinh Nguyenphu	Anthony Peck	Dennis Rehm
John Messenger	Henry T. Nicholas	Jan P. Peeters Weem	Eugene Reilly
Jo Beth Metzger	Larry Nicholson	Jan P. Peeters-Weem	Jim Reinstedler
Steve Metzger	Paul Nikolich	Arkadiy Peker	Maurice Reintjes
Yossi Meyouhas	David Nim	Joe Pelissier	Duane Remein
Amir Mezer	Glenn Nishida	Jim Pelster	Andreas Rendel
Tremont Miao	Shinji Nishimura	Y. Lisa Peng	Lawrence Rennie
Joseph Micallef	Kazuhiro Nojima	Petar Pepeljugoski	Victor Renteria
Richard Michalowski	Michael Nootbaar	Gerry Pesavento	Pedro Reviriego
Colin Mick	Ron Nordin	William R. Peters	Bill Reysen
Martin R. Milbury	Bob Norton	Brian Peterson	Behrooz Rezvani
Bruce D. Miller	Bob Noseworthy	Abhijit Phanse	Dave Richkas
C. Kenneth Miller	Ahmad Nouri	Thomas L. Phinney	Joseph Rickert
Larry D. Miller	Mark Nowell	David Piede	Sean Riley
Jacob (Kobi) Mizrahi	Ivan Oakley	Roy Pierce	John Ritger
Fanny Mlinarsky	Satoshi Obara	Robert Pieters	Paul Rivett
Reza Moattar	John Oberstar	Antti Pietilainen	Ramez Rizk
Fred Mohamadi	J. Michael O'Connor	Rick Pimpinella	Ramz Rizk
Dirk S. Mohl	Stephen Oh	Armin Pitzer	Anthony Rizzolo
Mart L. Molle	Peter Ohlén	Ed Pivonka	Gary Robinson
Ray Mompoin	Mitsuji Okada	Timothy R. Plunkett	Steven Robinson
John Monson	Vladimir Oksman	David Poisner	Stuart Robinson
Cindy Montstream	Guy P. Oliveira	Peter Pondillo	Timothy Rock
Charles Moore	Chris Oliver	Petre Popescu	Michael Rodensky
Paul B. Moore	Lloyd Oliver	Jeff Porter	A. Rodriguez
Robert Moore	Mike Oltmanns	Carl R. Posthuma	Carlos Rodriguez
Octavio Morales	Barry O'Mahony	Bill Poston	Shawn Rogers
Shohei Moriwaki	Keith Onodera	David Potter	Dan Romascanu
Robert L. Morrell	Toshio Ooka	Kimberly Pottratz	Tume Römer

Albrecht Rommel	Haim Shafir	Patrick H. Stanley	Paul Torgerson
David Roos	Amit Shah	Nick Stapleton	Luis Torres
Robert Rosenthal	Sunil Shah	Graham Starkins	Rick Townsend
Floyd Ross	Vadim Shain	Peter Staub	Hidehiro Toyoda
Tam Ross	Abhijit Shanbhag	Margit Stearns	Hiep Tran
Michael Rothenberg	Ron Shani	David E. Stein	Matt Traverso
Tony Rowell	Sam Shen	Gary Stephens	Thomas E. Truman
Archana Roy	Ben Sheppard	Claus Stetter	Shiji Tsuju
Larry Rubin	Paul Sherer	Ronald Steudler	Zbigniew Turlej
Paul F. Russo	Robbie Shergill	Donald S. Stewart	Edward Turner
Valerie Rybinski	Cheng-Chung Shih	Dean M. Stoddart	Wendell Turner
Hyunsurk (Eric) Ryu	Ramin Shirani	Daniel P. Stokesberry	Bulent Tusray
Khosrow Sadeghi	Zion Shohet	Mario Stoltz	Jacob Twersky
Dalit Sagi	Larry Shorthill	Steve Storozum	Bor-long Twu
Ed Sakaguchi	Avadhani Shridhar	Rick Strohmayer	Marcos Tzannes
Dolors Sala	Martin Siegmund	Stephen Strong	Herbert Uhl
Peter Sallaway	Som Sikdar	Richard Stuart	Jayshree Ullal
Michael M. Salzman	Nathan Silberman	Ron Sulyma	Steven Ulrich
Moni Samaan	Tim Simmons	Robert Summers	Gottfried Ungerboeck
Sam Sambasivan	Scott Simon	Ken F. Sumner	Sterling A. Vaden
Fred Sammartino	Bharat Singh	Tetsuyuki Suzaki	Todd Vafiades
Henry Samueli	Charan J. Singh	Hiroshi Suzuki	Magesh Valliappan
Anthony Sanders	Paramjeet (P. J.) Singh	Daniel Svensson	Nicholas Van Bavel
Mark Sankey	Semir Sirazi	Steve Swanson	Schelto J. van Doorn
Concita Saracino	Ramesh Sivakolundu	Norman L. Swenson	David J. Van Goor
Arindam Sarkar	Joseph Skorupa	Andre Szczepanek	Peter Van Laanen
Bill Sarles	James P. Skoutas	Daniel Sze	Erik van Oosten
F. Sarles	Dinah Sloan	Andre Szezepanek	Paul Z. Vanderlaan
Akira Sasaki	Tom Slykhouse	Tad Szostak	Schelto vanDoorn
Stan Sassower	Andrew Smith	Richard Taborek	Dono Van-Mierop
Raj Savara	David A. Smith	Bharat Tailor	Andre VanSchyndel
Olindo Savi	Eric Smith	Akio Tajima	Albert Vareljian
T. Shannon Sawyer	Grant Smith	Eiichi Takahashi	Kumaran Veerayah
Sabit Say-Otun	Michael Smith	Martin Takessian	V. Kumar Venkatavaraton
J. David Schell	Robert Smith	Wen-Tsung Tang	Ramakrishna Vepa
Dieter W. Schicketanz	Robert W. Smith	Sandray Tarana	Gérard Vergnaud
Fred Schindler	Steve Smith	Victor J. Tarassov	Bill Verheggen
Ronald Schmidt	Robert Snyder	Peter Tarrant	Iain Verigin
Tom Schmitt	Dror Sofer	Mike Tate	Robert Verne
Frederick Scholl	Ran Soffer	Jim Tatum	Nader Vijeh
Thomas Schramm	Gregory Somer	James M. Tavacoli	Ron Vilozny
Walter Schreuer	Jaeyeon Song	Sadry Tavana	John Visser
Ted Schroeder	Jian Song	Ken Taylor	David Vogel
Scott Schube	Massimo Sorbara	Mark Taylor	Moshe Voloshin
Benjamin Schultz	David Sorensen	Tim Teckman	Brian Von Herzen
Klaus Schulz	Michel Sørensen	Vivek Telang	John von Voros
David Schwartz	Walter Sotelo	José Tellado	Manoj Wadekar
Peter Schwartz	Stephen Soto	Patricia A. Thaler	William Wager
Harvey R. Scull	Walt Soto	R. Jonathan Thatcher	Martin Wagner
Anthony Seaman	Fulvio Spagna	Walter Thirion	P. E. Wainwright
Mick Seaman	Bryan Sparrowhawk	Geoffrey O. Thompson	Ikuo Wakayama
Stephn Sedio	Ben Speiser	Douglas Thomson	Rick Walker
Brian Seemann	Gary Spencer	Lars E. Thon	Chang Jung Wang
Khorvash Sefidvash	Michael Spratt	David Thorne	Chiung Hung Wang
Richard Seifert	Matthew B. Squire	Nathan Tobol	Greg Wang
Katsutoshi Seki	David Srodzinski	John Todd	Peter Wang
Steve Selee	Joseph St. Amand	Bruce Tolley	Yun-Che Wang
Lee Sendelbach	David N. Stacy	Carlos A. Tomaszewski	Ken Ward
Koichiro Seto	Clay Stanford	Peter Tomaszewski	Tim Warland

Jeff Warren	Bill Wiedemann	David Wong	Tae-Whan Yoo
Marc Warshaw	Joseph A. Wiencko	Don Wong	Chong Ho Yoon
Ted Washburn	Bruce Williams	Edward Wong	Jason Yorks
Yuji Watanabe	Richard Williams	Leo Wong	Osamu Yoshihara
Bruce Watson	Erica Williamson	Percy Wong	Takashi Yoshikawa
Robert Watson	Robert S. Williamson	Bill Woodruff	Leonard Young
Dong Wei	Roger Wilmarth	Paul Woodruff	Nariman Yousefi
Lyle Weiman	Joris Wils	Choa-Ping Wu	Ben Yu
Nick Weiner	Izumi Wilson	Robert Wu	Hong Yu
Alan Weissberger	Mike Wincn	Stefan M. Wurster	Mark Yu
Andrew Weitzner	Mark Wingrove	Ariel Yagil	Nick Zades
Moti Weizman	Darin Winterton	Michael Yam	Nelson Zagalsky
Jim Welch	Mike Witkowski	Shuntaro Yamazaki	Hank Zannini
Fred Weniger	Kevin Witt	Howard Yang	Jamie Zartman
Willem Wery	Andrew Witzner	Steven Yang	Jing-fan Zhang
Alan Wetzel	John Wolcott	Ronald Yara	Igor Zhovnirovsky
David White	Jonghwa Won	Lee Chung Yiu	George Zimmerman
Hugh E. White	King Won	Doug Yoder	Pavel Zivny
Lawrence White	Shin-Hee Won	Nobushige Yokota	Bob Zona
Tony Whitlow			Mo R. Zonoun

The following members of the individual balloting committee voted on this revision of the standard. Balloters may have voted for approval, disapproval, or abstention.

Thomas Alexander	Jaganathan Gnanavelu	Michael S. Newman
Danilo Antonelli	Sergiu Goma	Nick S. A. Nikjoo
Jacob Ben Ary	Randall Groves	Paul Nikolich
James Barnette	Robert M. Grow	Satoshi Obara
John Barr	C. Guy	George Oulundsen
Hugh Barrass	John Hawkins	Glenn Parsons
Michael Beck	Adam Healey	Michael Peppler
Michael Bennett	Atsushi Ito	Randall Safer
Parag Bhatt	Raj Jain	John Sargent
Ralf-Peter Braun	Piotr Karocki	Benson Schliesser
William Byrd	Sanjay Kasturia	Marco Scorrano
Jeffrey Cain	Stuart J. Kerry	Kapil Sood
Edward Carley	Yongbum Kim	Amjad Soomro
James Carlo	Paul Kolesar	Matthew Squire
Juan Carreon	David J. Law	Thomas Starai
Keith Chow	John Lemon	Walter Struppler
Charles Cook	William Lumpkins	Mitsutoshi Sugawara
John Dallesasse	G. Luri	Alourdes Sully
Piers J. G. Dawe	Valerie Maguire	Patricia Thaler
Wael Diab	Ahmad Mahinfallah	Geoffrey Thompson
Russell Dietz	Roger Marks	Michael Thompson
Thomas Dineen	Arthur Marris	Edward J. Turner
Michael Dudek	Peter Martini	Schelto Van Doorn
Paul Eastman	W. Kyle Maus	David Willow
Jose Dominic Espejo	Brett McClellan	Forrest Wright
C. Fitzgerald	John Messenger	Oren Yuen
Prince Francis	Tremont Miao	Janusz Zalewski
Howard M. Frazier	Dinesh Mohan	Paolo Zangheri
Yukihiro Fujimoto	Jose Morales	George Zimmerman
Devon Gayle	Joseph Moran	
Michael Geipel	Madihally J. Narasimha	

When the IEEE-SA Standards Board approved this standard on 26 September 2008, it had the following membership:

**Robert M. Grow**, *Chair*  
**Thomas Prevost**, *Vice Chair*  
**Steve M. Mills**, *Past Chair*  
**Judith Gorman**, *Secretary*

Victor Berman  
Richard DeBlasio  
Andy Drozd  
Mark Epstein  
Alexander Gelman  
William R. Goldbach  
Arnold M. Greenspan  
Kenneth S. Hanus

Jim Hughes  
Richard H. Hulett  
Young Kyun Kim  
Joseph L. Koepfinger\*  
John Kulick  
David J. Law  
Glenn Parsons  
Ronald C. Petersen

Chuck Powers  
Narayanan Ramachandran  
Jon Walter Rosdahl  
Robby Robson  
Anne-Marie Sahazizia  
Malcolm V. Thaden  
Howard L. Wolfman  
Don Wright

\*Member Emeritus

Also included are the following nonvoting IEEE-SA Standards Board liaisons:

Satish K. Aggarwal, *NRC Representative*  
Michael Janezic, *NIST Representative*

Michelle D. Turner  
*IEEE Standards Program Manager, Document Development*

Kathryn Cush  
*IEEE Standards Program Manager, Technical Program Development*

## List of special symbols

For the benefit of those who have received this document by electronic means, what follows is a list of special symbols and operators. If any of these symbols or operators fail to print out correctly on your machine, the editors apologize, and hope that this table will at least help you to sort out the meaning of the resulting funny-shaped blobs and strokes.

### Special symbols and operators

Printed character	Meaning	Font
*	Boolean AND	Symbol
+	Boolean OR, arithmetic addition	Symbol
^	Boolean XOR	Times New Roman
!	Boolean NOT	Symbol
×	Multiplication	Symbol
<	Less than	Symbol
≤	Less than or equal to	Symbol
>	Greater than	Symbol
≥	Greater than or equal to	Symbol
=	Equal to	Symbol
≠	Not equal to	Symbol
←	Assignment operator	Symbol
∈	Indicates membership	Symbol
∉	Indicates nonmembership	Symbol
±	Plus or minus (a tolerance)	Symbol
°	Degrees	Symbol
∑	Summation	Symbol
√	Square root	Symbol
—	Big dash (em dash)	Times New Roman
–	Little dash (en dash), subtraction	Times New Roman
	Vertical bar	Times New Roman
†	Dagger	Times New Roman
‡	Double dagger	Times New Roman
α	Lower case alpha	Symbol
β	Lower case beta	Symbol
γ	Lower case gamma	Symbol
δ	Lower case delta	Symbol
ε	Lower case epsilon	Symbol
λ	Lambda	Symbol
μ	Micro	Times New Roman
Ω	Omega	Symbol

# Contents

## SECTION ONE

1.	Introduction.....	1
1.1	Overview.....	1
1.1.1	Scope.....	1
1.1.2	Basic concepts.....	1
1.1.3	Architectural perspectives.....	2
1.1.4	Layer interfaces.....	5
1.1.5	Application areas .....	5
1.2	Notation .....	5
1.2.1	State diagram conventions .....	5
1.2.2	Service specification method and notation .....	6
1.2.3	Physical Layer and media notation .....	7
1.2.4	Physical Layer message notation .....	8
1.2.5	Hexadecimal notation .....	8
1.3	Normative references .....	8
1.4	Definitions .....	15
1.5	Abbreviations.....	39
2.	Media Access Control (MAC) service specification .....	45
2.1	Scope and field of application .....	45
2.2	Overview of the service .....	45
2.2.1	General description of services provided by the layer.....	45
2.2.2	Model used for the service specification .....	45
2.2.3	Overview of interactions.....	45
2.2.4	Basic services.....	46
2.3	Detailed service specification .....	46
2.3.1	MA_DATA.request .....	46
2.3.2	MA_DATA.indication.....	47
3.	Media Access Control (MAC) frame and packet specifications .....	49
3.1	Overview.....	49
3.1.1	Packet format .....	49
3.1.2	Service interface mappings.....	50
3.2	Elements of the MAC frame and packet.....	50
3.2.1	Preamble field .....	50
3.2.2	Start Frame Delimiter (SFD) field.....	50
3.2.3	Address fields .....	50
3.2.4	Destination Address field.....	51
3.2.5	Source Address field.....	52
3.2.6	Length/Type field .....	52
3.2.7	MAC Client Data field.....	52
3.2.8	Pad field .....	53
3.2.9	Frame Check Sequence (FCS) field.....	53
3.2.10	Extension field.....	53
3.3	Order of bit transmission .....	54
3.4	Invalid MAC frame.....	54



4.	Media Access Control.....	55
4.1	Functional model of the MAC method .....	55
4.1.1	Overview.....	55
4.1.2	CSMA/CD operation .....	56
4.1.3	Relationships to the MAC client and Physical Layers .....	58
4.2	CSMA/CD Media Access Control (MAC) method: Precise specification.....	58
4.2.1	Introduction.....	58
4.2.2	Overview of the procedural model .....	58
4.2.3	Packet transmission model.....	60
4.2.4	Frame reception model .....	69
4.2.5	Preamble generation .....	71
4.2.6	Start frame sequence.....	71
4.2.7	Global declarations .....	71
4.2.8	Frame transmission .....	75
4.2.9	Frame reception .....	82
4.2.10	Common procedures .....	85
4.3	Interfaces to/from adjacent layers.....	86
4.3.1	Overview.....	86
4.3.2	MAC service .....	86
4.3.3	Services required from the Physical Layer .....	89
4.4	Specific implementations.....	90
4.4.1	Compatibility overview .....	90
4.4.2	MAC parameters.....	91
4.4.3	Configuration guidelines.....	92
5.	Layer Management .....	93
5.1	Introduction.....	93
5.1.1	Systems Management overview .....	93
5.1.2	Layer Management model .....	93
5.1.3	Packages.....	94
5.1.4	Conformance requirements.....	94
5.2	Management facilities.....	94
5.2.1	Introduction.....	94
5.2.2	DTE MAC Sublayer Management facilities.....	94
5.2.3	DTE Physical Sublayer Management facilities .....	104
5.2.4	DTE Management procedural model.....	105
6.	Physical Signaling (PLS) service specifications.....	111
6.1	Scope and field of application .....	111
6.2	Overview of the service .....	111
6.2.1	General description of services provided by the layer.....	111
6.2.2	Model used for the service specification .....	111
6.2.3	Overview of interactions.....	111
6.2.4	Basic services and options .....	112
6.3	Detailed service specification .....	112
6.3.1	Peer-to-peer service primitives .....	112
6.3.2	Sublayer-to-sublayer service primitives .....	113
7.	Physical Signaling (PLS) and Attachment Unit Interface (AUI) specifications .....	115
7.1	Scope.....	115

7.1.1	Definitions .....	115
7.1.2	Summary of major concepts .....	115
7.1.3	Application.....	116
7.1.4	Modes of operation .....	116
7.1.5	Allocation of function.....	116
7.2	Functional specification.....	116
7.2.1	PLS–PMA (DTE–MAU) Interface protocol.....	116
7.2.2	PLS interface to MAC and management entities.....	123
7.2.3	Frame structure .....	125
7.2.4	PLS functions.....	126
7.3	Signal characteristics .....	129
7.3.1	Signal encoding.....	129
7.3.2	Signaling rate .....	134
7.3.3	Signaling levels.....	134
7.4	Electrical characteristics .....	134
7.4.1	Driver characteristics .....	134
7.4.2	Receiver characteristics .....	137
7.4.3	AUI cable characteristics.....	139
7.5	Functional description of interchange circuits.....	141
7.5.1	General.....	141
7.5.2	Definition of interchange circuits .....	141
7.6	Mechanical characteristics.....	143
7.6.1	Definition of mechanical interface .....	143
7.6.2	Line interface connector .....	143
7.6.3	Contact assignments .....	144
8.	Medium Attachment Unit and baseband medium specifications, type 10BASE5 .....	147
8.1	Scope.....	147
8.1.1	Overview.....	147
8.1.2	Definitions .....	148
8.1.3	Application perspective: MAU and MEDIUM objectives .....	148
8.2	MAU functional specifications.....	149
8.2.1	MAU Physical Layer functions .....	149
8.2.2	MAU interface messages.....	152
8.2.3	MAU state diagrams .....	154
8.3	MAU–medium electrical characteristics .....	154
8.3.1	MAU-to-coaxial cable interface .....	154
8.3.2	MAU electrical characteristics.....	161
8.3.3	MAU–DTE electrical characteristics.....	162
8.3.4	MAU–DTE mechanical connection.....	162
8.4	Characteristics of the coaxial cable .....	162
8.4.1	Coaxial cable electrical parameters .....	162
8.4.2	Coaxial cable properties.....	164
8.4.3	Total segment dc loop resistance .....	165
8.5	Coaxial trunk cable connectors.....	165
8.5.1	Inline coaxial extension connector .....	165
8.5.2	Coaxial cable terminator.....	166
8.5.3	MAU-to-coaxial cable connection.....	166
8.6	System considerations.....	168
8.6.1	Transmission system model.....	168
8.6.2	Transmission system requirements.....	169
8.6.3	Labeling .....	170
8.7	Environmental specifications.....	170

8.7.1	General safety requirements .....	170
8.7.2	Network safety requirements .....	170
8.7.3	Electromagnetic environment .....	172
8.7.4	Temperature and humidity .....	172
8.7.5	Regulatory requirements .....	172
8.8	Protocol implementation conformance statement (PICS) proforma for Clause 8, Medium Attachment Unit and baseband medium specifications, type 10BASE5 .....	173
8.8.1	Overview .....	173
8.8.2	Abbreviations and special symbols .....	173
8.8.3	Instructions for completing the PICS proforma .....	173
8.8.4	Identification .....	175
8.8.5	Global statement of conformance .....	175
8.8.6	PICS proforma tables for MAU .....	176
8.8.7	PICS proforma tables for MAU AUI characteristics .....	183
8.8.8	PICS proforma tables for 10BASE5 coaxial cable .....	187
9.	Repeater unit for 10 Mb/s baseband networks .....	189
9.1	Overview .....	189
9.2	References .....	190
9.3	Definitions .....	190
9.4	Compatibility interface .....	190
9.4.1	AUI compatibility .....	190
9.4.2	Mixing segment compatibility .....	190
9.4.3	Link segment compatibility .....	191
9.5	Basic functions .....	191
9.5.1	Repeater set network properties .....	191
9.5.2	Signal amplification .....	191
9.5.3	Signal symmetry .....	191
9.5.4	Signal retiming .....	192
9.5.5	Data handling .....	192
9.5.6	Collision handling .....	193
9.5.7	Electrical isolation .....	194
9.6	Detailed repeater functions and state diagrams .....	195
9.6.1	State diagram notation .....	195
9.6.2	Data and collision handling .....	198
9.6.3	Preamble regeneration .....	198
9.6.4	Fragment extension .....	198
9.6.5	MAU Jabber Lockup Protection .....	199
9.6.6	Auto-Partitioning/Reconnection (optional) .....	199
9.7	Electrical isolation .....	202
9.8	Reliability .....	202
9.9	Medium attachment unit and baseband medium specification for a vendor-independent FOIRL .....	203
9.9.1	Scope .....	203
9.9.2	FOMAU functional specifications .....	205
9.9.3	FOMAU electrical characteristics .....	211
9.9.4	FOMAU/Optical medium interface .....	212
9.9.5	Characteristics of the optical fiber cable link segment .....	215
9.9.6	System requirements .....	216
9.9.7	Environmental specifications .....	218
10.	Medium attachment unit and baseband medium specifications, type 10BASE2 .....	221

10.1	Scope.....	221
10.1.1	Overview.....	221
10.1.2	Definitions .....	222
10.1.3	Application perspective: MAU and medium objectives.....	222
10.2	References.....	223
10.3	MAU functional specifications.....	223
10.3.1	MAU Physical Layer functional requirements .....	224
10.3.2	MAU interface messages.....	226
10.3.3	MAU state diagrams .....	228
10.4	MAU–medium electrical characteristics .....	229
10.4.1	MAU-to-coaxial cable interface .....	229
10.4.2	MAU electrical characteristics.....	231
10.4.3	MAU–DTE electrical characteristics.....	232
10.5	Characteristics of coaxial cable system .....	232
10.5.1	Coaxial cable electrical parameters .....	232
10.5.2	Coaxial cable physical parameters.....	233
10.5.3	Total segment dc loop resistance .....	234
10.6	Coaxial trunk cable connectors.....	235
10.6.1	In-line coaxial extension connector .....	235
10.6.2	Coaxial cable terminator.....	236
10.6.3	MAU-to-coaxial cable connection.....	236
10.7	System considerations.....	236
10.7.1	Transmission system model.....	236
10.7.2	Transmission system requirements .....	238
10.8	Environmental specifications.....	239
10.8.1	Safety requirements .....	239
10.8.2	Electromagnetic environment.....	239
10.8.3	Regulatory requirements.....	239
11.	Broadband medium attachment unit and broadband medium specifications, type 10BROAD36 .	241
11.1	Scope.....	241
11.1.1	Overview.....	241
11.1.2	Definitions .....	243
11.1.3	MAU and medium objectives .....	243
11.1.4	Compatibility considerations .....	244
11.1.5	Relationship to PLS and AUI .....	244
11.1.6	Mode of operation.....	244
11.2	MAU functional specifications.....	244
11.2.1	MAU functional requirements.....	244
11.2.2	DTE PLS to MAU and MAU to DTE PLS messages .....	247
11.2.3	MAU state diagrams .....	248
11.3	MAU characteristics .....	251
11.3.1	MAU-to-coaxial cable interface .....	251
11.3.2	MAU frequency allocations.....	256
11.3.3	AUI electrical characteristics.....	257
11.3.4	MAU transfer characteristics .....	258
11.3.5	Reliability.....	264
11.4	System considerations.....	265
11.4.1	Delay budget and network diameter .....	265
11.4.2	MAU operation with packets shorter than 512 bits .....	265
11.5	Characteristics of the coaxial cable system .....	266
11.5.1	Electrical requirements .....	266
11.5.2	Mechanical requirements.....	266

11.5.3	Delay requirements .....	266
11.6	Frequency translator requirements for the single-cable version .....	267
11.6.1	Electrical requirements .....	267
11.6.2	Mechanical requirements .....	267
11.7	Environmental specifications .....	267
11.7.1	Safety requirements .....	267
11.7.2	Electromagnetic environment .....	268
11.7.3	Temperature and humidity .....	268
12.	Physical signaling, medium attachment, and baseband medium specifications, type 1BASE5 .....	269
12.1	Introduction .....	269
12.1.1	Overview .....	269
12.1.2	Scope .....	269
12.1.3	Definitions .....	269
12.1.4	General characteristics .....	269
12.1.5	Compatibility .....	270
12.1.6	Objectives of type 1BASE5 specification .....	270
12.2	Architecture .....	270
12.2.1	Major concepts .....	270
12.2.2	Application perspective .....	271
12.2.3	Packet structure .....	271
12.3	DTE physical signaling (PLS) specification .....	274
12.3.1	Overview .....	274
12.3.2	Functional specification .....	275
12.4	Hub specification .....	281
12.4.1	Overview .....	281
12.4.2	Hub structure .....	282
12.4.3	Hub PLS functional specification .....	283
12.5	Physical medium attachment (PMA) specification .....	288
12.5.1	Overview .....	288
12.5.2	PLS–PMA interface .....	288
12.5.3	Signal characteristics .....	289
12.6	Medium Dependent Interface (MDI) specification .....	296
12.6.1	Line interface connector .....	296
12.6.2	Connector contact assignments .....	297
12.6.3	Labeling .....	297
12.7	Cable medium characteristics .....	298
12.7.1	Overview .....	298
12.7.2	Transmission parameters .....	298
12.7.3	Coupling parameters .....	299
12.7.4	Noise environment .....	300
12.8	Special link specification .....	301
12.8.1	Overview .....	301
12.8.2	Transmission characteristics .....	301
12.8.3	Permitted configurations .....	301
12.9	Timing .....	301
12.9.1	Overview .....	301
12.9.2	DTE timing .....	302
12.9.3	Medium timing .....	302
12.9.4	Special link timing .....	302
12.9.5	Hub timing .....	302
12.10	Safety .....	303

12.10.1	Isolation .....	303
12.10.2	Telephony voltages .....	304
13.	System considerations for multisegment 10 Mb/s baseband networks .....	305
13.1	Overview .....	305
13.1.1	Repeater usage .....	306
13.2	Definitions .....	306
13.3	Transmission System Model 1 .....	306
13.4	Transmission System Model 2 .....	312
13.4.1	Round-trip collision delay .....	312
13.4.2	Interpacket gap (IPG) shrinkage .....	313
13.5	Full duplex topology limitations .....	314
14.	Twisted-pair medium attachment unit (MAU) and baseband medium, type 10BASE-T .....	315
14.1	Scope .....	315
14.1.1	Overview .....	315
14.1.2	Definitions .....	316
14.1.3	Application perspective .....	316
14.1.4	Relationship to PLS and AUI .....	318
14.2	MAU functional specifications .....	318
14.2.1	MAU functions .....	319
14.2.2	PMA interface messages .....	323
14.2.3	MAU state diagrams .....	324
14.3	MAU electrical specifications .....	330
14.3.1	MAU-to-MDI interface characteristics .....	330
14.3.2	MAU-to-AUI specification .....	340
14.4	Characteristics of the simplex link segment .....	340
14.4.1	Overview .....	340
14.4.2	Transmission parameters .....	340
14.4.3	Coupling parameters .....	341
14.4.4	Noise environment .....	342
14.5	MDI specification .....	343
14.5.1	MDI connectors .....	343
14.5.2	Crossover function .....	343
14.6	System considerations .....	344
14.7	Environmental specifications .....	345
14.7.1	General safety .....	345
14.7.2	Network safety .....	345
14.7.3	Environment .....	346
14.8	MAU labeling .....	346
14.9	Timing summary .....	347
14.10	Protocol implementation conformance statement (PICS) proforma for Clause 14, Twisted-pair medium attachment unit (MAU) and baseband medium, type 10BASE-T .....	348
14.10.1	Introduction .....	348
14.10.2	Identification of implementation .....	349
14.10.3	Identification of the protocol .....	349
14.10.4	PICS proforma for 10BASE-T .....	350
15.	Fiber optic medium and common elements of medium attachment units and star, type 10BASE-F .....	365

15.1	Scope.....	365
15.1.1	Overview.....	365
15.1.2	Definitions .....	367
15.1.3	Applications perspective: MAUs, stars, and fiber optic medium .....	367
15.2	MDI optical characteristics.....	370
15.2.1	Transmit optical parameters.....	370
15.2.2	Receive optical parameters .....	377
15.3	Characteristics of the fiber optic medium.....	378
15.3.1	Optical fiber and cable.....	378
15.3.2	Optical medium connector plug and socket.....	379
15.3.3	Fiber optic medium insertion loss.....	380
15.3.4	Electrical isolation .....	380
15.4	MAU reliability.....	380
15.5	MAU–AUI specification.....	380
15.5.1	MAU–AUI electrical characteristics .....	380
15.5.2	MAU–AUI mechanical connections.....	381
15.5.3	Power consumption.....	381
15.5.4	MAU–AUI messages .....	381
15.6	Environmental specifications.....	382
15.6.1	Safety requirements .....	382
15.6.2	Electromagnetic environment .....	382
15.6.3	Other environmental requirements .....	383
15.7	MAU labeling .....	383
15.7.1	10BASE-FP star labeling.....	383
15.8	Protocol implementation conformance statement (PICS) proforma for Clause 15, Fiber optic medium and common elements of medium attachment units and star, type 10BASE-F.....	384
15.8.1	Introduction.....	384
15.8.2	Abbreviations and special symbols.....	384
15.8.3	Instructions for completing the pics proforma.....	384
15.8.4	Identification.....	386
15.8.5	Major capabilities/options.....	387
15.8.6	PICS Proforma for the fiber optic medium.....	387
16.	Fiber optic passive star and medium attachment unit, type 10BASE-FP.....	389
16.1	Scope.....	389
16.1.1	Overview.....	389
16.2	PMA interface messages.....	390
16.2.1	PMA-to-MDI interface signal encodings .....	390
16.2.2	PMA-to-MDI OTD messages.....	390
16.2.3	MDI ORD-to-PMA messages.....	391
16.3	10BASE-FP MAU functional specifications.....	392
16.3.1	Transmit function requirements.....	392
16.3.2	Receive function requirements .....	394
16.3.3	Loopback function requirements .....	395
16.3.4	Collision presence function requirements.....	395
16.3.5	signal_quality_error Message (SQE) Test function requirements.....	396
16.3.6	Jabber function requirements.....	396
16.3.7	Link fault detection and low light function requirements.....	397
16.3.8	Interface message time references .....	398
16.3.9	MAU state diagram.....	398
16.4	Timing summary.....	406
16.5	10BASE-FP Star functional specifications.....	406

16.5.1	Star functions .....	406
16.5.2	Star optical characteristics .....	407
16.6	Protocol implementation conformance statement (PICS) proforma for Clause 16, Fiber optic passive star and medium attachment unit, type 10BASE-FP .....	408
16.6.1	Introduction .....	408
16.6.2	Abbreviations and special symbols .....	408
16.6.3	Instructions for completing the PICS proforma .....	408
16.6.4	Identification .....	410
16.6.5	Major capabilities/options .....	411
16.6.6	PICS proforma for the type 10BASE-FP MAU .....	411
16.6.7	PICS proforma tables for 10BASE-FP stars .....	423
17.	Fiber optic medium attachment unit, type 10BASE-FB .....	425
17.1	Scope .....	425
17.1.1	Overview .....	425
17.1.2	Relationship to AUI .....	425
17.2	PMA interface messages .....	426
17.2.1	PMA-to-MDI interface signal encodings .....	426
17.2.2	PMA-to-MDI OTD messages .....	426
17.2.3	MDI ORD-to-PMA messages .....	427
17.2.4	Transitions between signals .....	428
17.2.5	Signaling rate .....	428
17.3	MAU functional specifications .....	428
17.3.1	Transmit function requirements .....	428
17.3.2	Receive function requirements .....	429
17.3.3	Collision function requirements .....	429
17.3.4	Loopback function requirements .....	430
17.3.5	Fault-handling function requirements .....	430
17.3.6	Jabber function requirements .....	430
17.3.7	Low light level detection function requirements .....	431
17.3.8	Synchronous qualification function requirements .....	431
17.3.9	Interface message time references .....	431
17.3.10	MAU state diagrams .....	432
17.4	Timing summary .....	436
17.5	Protocol implementation conformance statement (PICS) proforma for Clause 17, Fiber optic medium attachment unit, type 10BASE-FB .....	437
17.5.1	Introduction .....	437
17.5.2	Abbreviations and special symbols .....	437
17.5.3	Instructions for completing the PICS proforma .....	437
17.5.4	Identification .....	439
17.5.5	PICS proforma for the type 10BASE-FB MAU .....	439
17.5.6	PICS proforma for the type 10BASE-FB MAU .....	440
18.	Fiber optic medium attachment unit, type 10BASE-FL .....	451
18.1	Scope .....	451
18.1.1	Overview .....	451
18.2	PMA interface messages .....	451
18.2.1	PMA to fiber optic link segment messages .....	452
18.2.2	Fiber optic link segment to PMA messages .....	452
18.2.3	Interface message time references .....	453
18.3	MAU functional specifications .....	453
18.3.1	MAU functions .....	453



18.3.2	MAU state diagrams .....	457
18.4	Timing summary .....	464
18.5	Protocol implementation conformance statement (PICS) proforma for Clause 18, Fiber optic medium attachment unit, type 10BASE-FL .....	465
18.5.1	Introduction .....	465
18.5.2	Abbreviations and special symbols .....	465
18.5.3	Instructions for completing the PICS proforma .....	466
18.5.4	Identification .....	467
18.5.5	Major capabilities/options .....	468
18.5.6	PICS proforma tables for the type 10BASE-FL MAU .....	468
19.	Layer Management for 10 Mb/s baseband repeaters .....	481
19.1	Introduction .....	481
19.1.1	Scope .....	481
19.1.2	Relationship to objects in IEEE Std 802.1F-1993 .....	481
19.1.3	Definitions .....	481
19.1.4	Symbols and abbreviations .....	481
19.1.5	Management model .....	482
19.2	Managed objects .....	483
19.2.1	Introduction .....	483
19.2.2	Overview of managed objects .....	483
19.2.3	Repeater managed object class .....	488
19.2.4	ResourceTypeID Managed Object Class .....	491
19.2.5	Group managed object class .....	491
19.2.6	Port managed object class .....	492
20.	Layer Management for 10 Mb/s baseband medium attachment units .....	499
20.1	Introduction .....	499
20.1.1	Scope .....	499
20.1.2	Management model .....	499
20.2	Managed objects .....	499
20.2.1	Text description of managed objects .....	499
20.2.2	MAU Managed object class .....	501
	Annex A (informative) Bibliography .....	505
	Annex B (informative) System guidelines .....	509
B.1	Baseband system guidelines and concepts, 10 Mb/s .....	509
B.2	System parameters and budgets for 1BASE5 .....	521
B.3	Example crosstalk computation for multiple disturbers, balanced-pair cable .....	524
B.4	10BASE-T guidelines .....	526
B.5	10BASE-F .....	529
	Annex C (informative) State diagram, MAC sublayer .....	532
	Annex D (informative) Application context, selected medium specifications .....	533
D.1	Introduction .....	533
D.2	Type 10BASE5 applications .....	533
D.3	Type 10BASE2 applications .....	533
D.4	Type FOIRL and 10BASE-F applications; alternative fiber optic medium applications .....	534

D.5	10BASE-T use of cabling systems with a nominal differential characteristic impedance of 120 $\Omega$ .....	537
D.6	10BASE-T use of cabling systems with a nominal differential characteristic impedance of 150 $\Omega$ .....	538
Annex E (informative)	Receiver wavelength design considerations (FOIRL).....	540
Annex F (normative)	Additional attributes required for systems .....	541
F.1	Introduction.....	541
F.2	Objects/Attributes/Actions/Notifications.....	541
Annex G (normative)	Additional material required for conformance testing .....	543
G.1	Introduction.....	543
Annex H (normative)	GDMO specifications for CSMA/CD managed objects .....	544
H.1	Use of MAC and PLS Sublayer Management Definitions with CMIS/CMIP and ISO/IEC 15802-2: 1995 Management Protocols .....	544
H.2	GDMO specification for Repeater Management Object Class.....	554
H.3	GDMO specification for MAU Management Objects.....	565
H.4	GDMO and ASN.1 definitions for management .....	568
Annex 4A (normative)	Simplified full duplex media access control .....	573
4A.1	Functional model of the MAC method .....	573
4A.2	Media access control (MAC) method: precise specification .....	575
4A.3	Interfaces to/from adjacent layers.....	592
4A.4	Specific implementations.....	596

**SECTION TWO**

- 21. Introduction to 100 Mb/s baseband networks, type 100BASE-T ..... 1
  - 21.1 Overview..... 1
    - 21.1.1 Reconciliation Sublayer (RS) and Media Independent Interface (MII) ..... 1
    - 21.1.2 Physical Layer signaling systems ..... 2
    - 21.1.3 Repeater ..... 2
    - 21.1.4 Auto-Negotiation ..... 2
    - 21.1.5 Management..... 3
  - 21.2 References..... 3
  - 21.3 Definitions ..... 3
  - 21.4 Abbreviations..... 3
  - 21.5 State diagrams..... 3
    - 21.5.1 Actions inside state blocks..... 3
    - 21.5.2 State diagram variables ..... 3
    - 21.5.3 State transitions..... 4
    - 21.5.4 Operators..... 4
  - 21.6 Protocol implementation conformance statement (PICS) proforma..... 5
    - 21.6.1 Introduction..... 5
    - 21.6.2 Abbreviations and special symbols..... 5
    - 21.6.3 Instructions for completing the PICS proforma..... 5
    - 21.6.4 Additional information ..... 6
    - 21.6.5 Exceptional information ..... 6
    - 21.6.6 Conditional items..... 6
  - 21.7 Relation of 100BASE-T to other standards ..... 7
  - 21.8 MAC delay constraints (exposed MII) ..... 8
- 22. Reconciliation Sublayer (RS) and Media Independent Interface (MII)..... 9
  - 22.1 Overview..... 9
    - 22.1.1 Summary of major concepts ..... 10
    - 22.1.2 Application..... 10
    - 22.1.3 Rates of operation ..... 11
    - 22.1.4 Allocation of functions ..... 11
    - 22.1.5 Relationship of MII and GMII..... 11
  - 22.2 Functional specifications ..... 11
    - 22.2.1 Mapping of MII signals to PLS service primitives and Station Management..... 11
    - 22.2.2 MII signal functional specifications ..... 15
    - 22.2.3 MII data stream..... 21
    - 22.2.4 Management functions..... 24
  - 22.3 Signal timing characteristics..... 38
    - 22.3.1 Signals that are synchronous to TX\_CLK ..... 38
    - 22.3.2 Signals that are synchronous to RX\_CLK ..... 39
    - 22.3.3 Signals that have no required clock relationship ..... 40
    - 22.3.4 MDIO timing relationship to MDC ..... 40
  - 22.4 Electrical characteristics ..... 41
    - 22.4.1 Signal levels..... 41
    - 22.4.2 Signal paths..... 41
    - 22.4.3 Driver characteristics ..... 42
    - 22.4.4 Receiver characteristics ..... 42
    - 22.4.5 Cable characteristics ..... 43
    - 22.4.6 Hot insertion and removal..... 44
  - 22.5 Power supply..... 45

22.5.1	Supply voltage .....	45
22.5.2	Load current .....	45
22.5.3	Short-circuit protection .....	45
22.6	Mechanical characteristics .....	45
22.6.1	Definition of mechanical interface .....	45
22.6.2	Shielding effectiveness and transfer impedance .....	46
22.6.3	Connector pin numbering .....	46
22.6.4	Clearance dimensions .....	46
22.6.5	Contact assignments .....	47
22.7	Protocol implementation conformance statement (PICS) proforma for Clause 22, Reconciliation Sublayer (RS) and Media Independent Interface (MII) .....	48
22.7.1	Introduction .....	48
22.7.2	Identification .....	48
22.7.3	PICS proforma tables for reconciliation sublayer and media independent interface .....	49
23.	Physical Coding Sublayer (PCS), Physical Medium Attachment (PMA) sublayer and baseband medium, type 100BASE-T4 .....	59
23.1	Overview .....	59
23.1.1	Scope .....	59
23.1.2	Objectives .....	59
23.1.3	Relation of 100BASE-T4 to other standards .....	59
23.1.4	Summary .....	59
23.1.5	Application of 100BASE-T4 .....	62
23.2	PCS functional specifications .....	63
23.2.1	PCS functions .....	63
23.2.2	PCS interfaces .....	68
23.2.3	Frame structure .....	68
23.2.4	PCS state diagrams .....	69
23.2.5	PCS electrical specifications .....	77
23.3	PMA service interface .....	77
23.3.1	PMA_TYPE.indication .....	78
23.3.2	PMA_UNITDATA.request .....	78
23.3.3	PMA_UNITDATA.indication .....	79
23.3.4	PMA_CARRIER.indication .....	80
23.3.5	PMA_LINK.indication .....	80
23.3.6	PMA_LINK.request .....	81
23.3.7	PMA_RXERROR.indication .....	82
23.4	PMA functional specifications .....	82
23.4.1	PMA functions .....	82
23.4.2	PMA interface messages .....	86
23.4.3	PMA state diagrams .....	87
23.5	PMA electrical specifications .....	89
23.5.1	PMA-to-MDI interface characteristics .....	89
23.5.2	Power consumption .....	103
23.6	Link segment characteristics .....	103
23.6.1	Cabling .....	103
23.6.2	Link transmission parameters .....	104
23.6.3	Noise .....	106
23.6.4	Installation practice .....	107
23.7	MDI specification .....	107
23.7.1	MDI connectors .....	107
23.7.2	Crossover function .....	108

23.8	System considerations.....	108
23.9	Environmental specifications.....	109
23.9.1	General safety .....	109
23.9.2	Network safety.....	109
23.9.3	Environment.....	111
23.10	PHY labeling.....	111
23.11	Timing summary.....	111
23.11.1	Timing references .....	111
23.11.2	Definitions of controlled parameters .....	112
23.11.3	Table of required timing values .....	114
23.12	Protocol implementation conformance statement (PICS) proforma for Clause 23, Physical Coding Sublayer (PCS), Physical Medium Attachment (PMA) sublayer, and baseband medium, type 100BASE-T4 .....	122
23.12.1	Introduction.....	122
23.12.2	Identification.....	122
23.12.3	Major capabilities/options.....	123
23.12.4	PICS proforma tables for the Physical Coding Sublayer (PCS), Physical Medium Attachment (PMA) sublayer and baseband medium, type 100BASE-T4 .....	123
24.	Physical Coding Sublayer (PCS) and Physical Medium Attachment (PMA) sublayer, type 100BASE-X.....	137
24.1	Overview.....	137
24.1.1	Scope.....	137
24.1.2	Objectives .....	137
24.1.3	Relationship of 100BASE-X to other standards .....	137
24.1.4	Summary of 100BASE-X sublayers .....	138
24.1.5	Inter-sublayer interfaces .....	139
24.1.6	Functional block diagram .....	139
24.1.7	State diagram conventions .....	139
24.2	Physical Coding Sublayer (PCS).....	142
24.2.1	Service Interface (MII) .....	142
24.2.2	Functional requirements .....	142
24.2.3	State variables .....	147
24.2.4	State diagrams.....	149
24.3	Physical Medium Attachment (PMA) sublayer.....	155
24.3.1	Service interface .....	155
24.3.2	Functional requirements .....	158
24.3.3	State variables .....	160
24.3.4	Process specifications and state diagrams .....	162
24.4	Physical Medium Dependent (PMD) sublayer service interface.....	166
24.4.1	PMD service interface .....	166
24.4.2	Medium Dependent Interface (MDI).....	168
24.5	Compatibility considerations .....	168
24.6	Delay constraints.....	168
24.6.1	PHY delay constraints (exposed MII) .....	169
24.6.2	DTE delay constraints (unexposed MII).....	169
24.6.3	Carrier de-assertion/assertion constraint (half duplex mode only).....	170
24.7	Environmental specifications.....	170
24.8	Protocol implementation conformance statement (PICS) proforma for Clause 24, Physical Coding Sublayer (PCS) and Physical Medium Attachment (PMA) sublayer, type 100BASE-X.....	171
24.8.1	Introduction.....	171
24.8.2	Identification.....	171

24.8.3	PICS proforma tables for the Physical Coding Sublayer (PCS) and Physical Medium Attachment (PMA) sublayer, type 100BASE-X .....	172
25.	Physical Medium Dependent (PMD) sublayer and baseband medium, type 100BASE-TX.....	175
25.1	Overview.....	175
25.2	Functional specifications .....	175
25.3	General exceptions.....	175
25.4	Specific requirements and exceptions.....	176
25.4.1	Change to 7.2.3.1.1, “Line state patterns” .....	176
25.4.2	Change to 7.2.3.3, “Loss of synchronization” .....	176
25.4.3	Change to Table 8-1, “Contact assignments for unshielded twisted pair” .....	177
25.4.4	Deletion of 8.3, “Station labelling” .....	177
25.4.5	Replacement of 8.4.1, “UTP isolation requirements” .....	177
25.4.6	Change to 9.1.9, “Jitter”.....	177
25.4.7	UTP cable plant .....	178
25.4.8	Replacement of 11.2, “Crossover function” .....	179
25.4.9	Change to A.2, “DDJ test pattern for baseline wander measurements” .....	179
25.4.10	Change to Annex G, “Stream cipher scrambling function” .....	179
25.4.11	Change to Annex I, “Common mode cable termination” .....	179
25.5	Protocol implementation conformance statement (PICS) proforma for Clause 25, Physical Medium Dependent (PMD) sublayer and baseband medium, type 100BASE-TX .....	180
25.5.1	Introduction.....	180
25.5.2	Identification .....	180
25.5.3	Major capabilities/options.....	181
25.5.4	PICS proforma tables for the Physical Medium Dependent (PMD) sublayer and baseband medium, type 100BASE-TX.....	181
26.	Physical Medium Dependent (PMD) sublayer and baseband medium, type 100BASE-FX.....	183
26.1	Overview.....	183
26.2	Functional specifications .....	183
26.3	General exceptions.....	183
26.4	Specific requirements and exceptions.....	184
26.4.1	Medium Dependent Interface (MDI).....	184
26.4.2	Crossover function.....	184
26.5	Protocol implementation conformance statement (PICS) proforma for Clause 26, Physical Medium Dependent (PMD) sublayer and baseband medium, type 100BASE-FX .....	185
26.5.1	Introduction.....	185
26.5.2	Identification .....	185
26.5.3	Protocol summary .....	185
26.5.4	Major capabilities/options.....	186
26.5.5	PICS proforma tables for Physical Medium Dependent (PMD) sublayer and baseband medium, type 100BASE-FX.....	186
27.	Repeater for 100 Mb/s baseband networks.....	187
27.1	Overview.....	187
27.1.1	Scope.....	187
27.1.2	Application perspective .....	188
27.1.3	Relationship to PHY .....	189
27.2	PMA interface messages.....	189
27.3	Repeater functional specifications .....	189
27.3.1	Repeater functions .....	190

27.3.2	Detailed repeater functions and state diagrams .....	194
27.4	Repeater electrical specifications.....	208
27.4.1	Electrical isolation .....	208
27.5	Environmental specifications.....	208
27.5.1	General safety .....	208
27.5.2	Network safety.....	208
27.5.3	Electrical isolation .....	209
27.5.4	Reliability.....	209
27.5.5	Environment.....	210
27.6	Repeater labeling .....	210
27.7	Protocol implementation conformance statement (PICS) proforma for Clause 27, Repeater for 100 Mb/s baseband networks .....	211
27.7.1	Introduction.....	211
27.7.2	Identification.....	211
27.7.3	Major capabilities/options.....	212
27.7.4	PICS proforma tables for the repeater for 100 Mb/s baseband networks.....	212
28.	Physical Layer link signaling for Auto-Negotiation on twisted pair .....	221
28.1	Overview.....	221
28.1.1	Scope.....	221
28.1.2	Application perspective/objectives .....	222
28.1.3	Relationship to ISO/IEC 8802-3 .....	222
28.1.4	Compatibility considerations .....	223
28.2	Functional specifications .....	224
28.2.1	Transmit function requirements.....	225
28.2.2	Receive function requirements .....	229
28.2.3	Arbitration function requirements .....	231
28.2.4	Management function requirements .....	237
28.2.5	Absence of management function.....	243
28.2.6	Technology-Dependent Interface .....	243
28.3	State diagrams and variable definitions .....	245
28.3.1	State diagram variables.....	246
28.3.2	State diagram timers .....	252
28.3.3	State diagram counters.....	255
28.3.4	State diagrams.....	256
28.4	Electrical specifications .....	259
28.5	Protocol implementation conformance statement (PICS) proforma for Clause 28, Physical Layer link signaling for Auto-Negotiation on twisted pair.....	260
28.5.1	Introduction.....	260
28.5.2	Identification.....	260
28.5.3	Major capabilities/options.....	261
28.5.4	PICS proforma tables for Physical Layer link signaling for Auto-Negotiation on twisted pair.....	261
28.6	Auto-Negotiation expansion .....	275
29.	System considerations for multisegment 100BASE-T networks .....	277
29.1	Overview.....	277
29.2	Transmission System Model 1 .....	279
29.3	Transmission System Model 2.....	279
29.3.1	Round-trip collision delay .....	281
29.4	Full duplex 100 Mb/s topology limitations.....	284

30.	Management.....	285
30.1	Overview.....	285
30.1.1	Scope.....	286
30.1.2	Relationship to objects in IEEE 802.1F.....	286
30.1.3	Systems management overview.....	287
30.1.4	Management model.....	287
30.2	Managed objects.....	288
30.2.1	Introduction.....	288
30.2.2	Overview of managed objects.....	288
30.2.3	Containment.....	294
30.2.4	Naming.....	294
30.2.5	Capabilities.....	294
30.3	Layer management for DTEs.....	313
30.3.1	MAC entity managed object class.....	313
30.3.2	PHY devicePHY device managed object class.....	324
30.3.3	MAC control entity object class.....	327
30.3.4	PAUSE entity managed object class.....	329
30.3.5	MPCP managed object class.....	329
30.3.6	OAM object class.....	336
30.3.7	OMPEmulation managed object class.....	350
30.4	Layer management for 10, 100, and 1000 Mb/s baseband repeaters.....	352
30.4.1	Repeater managed object class.....	352
30.4.2	Group managed object class.....	356
30.4.3	Repeater port managed object class.....	357
30.5	Layer management for medium attachment units (MAUs).....	363
30.5.1	MAU managed object class.....	363
30.6	Management for link Auto-Negotiation.....	373
30.6.1	Auto-Negotiation managed object class.....	373
30.7	Management for Link Aggregation.....	377
30.7.1	Aggregator managed object class.....	377
30.8	Management for WAN Interface Sublayer (WIS).....	401
30.8.1	WIS managed object class.....	401
30.9	Management for Power Sourcing Equipment (PSE).....	408
30.9.1	PSE managed object class.....	408
30.10	Layer management for Midspan.....	411
30.10.1	Midspan managed object class.....	411
30.10.2	PSE Group managed object class.....	412
30.11	Layer Management for Physical Medium Entity (PME).....	413
30.11.1	PAF managed object class.....	413
30.11.2	PME managed object class.....	417
31.	MAC Control.....	421
31.1	Overview.....	421
31.2	Layer architecture.....	421
31.3	Support by interlayer interfaces.....	421
31.3.1	MA_CONTROL.request.....	423
31.3.2	MA_CONTROL.indication.....	423
31.4	MAC Control frames.....	424
31.4.1	MAC Control frame format.....	424
31.5	Opcode-independent MAC Control sublayer operation.....	425
31.5.1	Frame parsing and data frame reception.....	425
31.5.2	Control frame reception.....	426



31.5.3	Opcode-independent MAC Control receive state diagram .....	426
31.6	Compatibility requirements .....	428
31.7	MAC Control client behavior .....	428
31.8	Protocol implementation conformance statement (PICS) proforma for Clause 31, MAC Control .....	429
31.8.1	Introduction .....	429
31.8.2	Identification .....	429
31.8.3	PICS proforma for MAC Control frames .....	430
32.	Physical Coding Sublayer (PCS), Physical Medium Attachment (PMA) sublayer and baseband medium, type 100BASE-T2 .....	431
32.1	Overview .....	431
32.1.1	Relation of 100BASE-T2 to other standards .....	431
32.1.2	Operation of 100BASE-T2 .....	431
32.1.3	Application of 100BASE-T2 .....	436
32.1.4	State diagram conventions .....	436
32.2	PHY Control functional specifications and service interface .....	436
32.2.1	PHY Control function .....	436
32.2.2	PHY Control Service interface .....	437
32.2.3	State diagram variables .....	439
32.2.4	State diagram timers .....	440
32.2.5	PHY Control state diagram .....	441
32.3	PCS functional specifications .....	441
32.3.1	PCS functions .....	443
32.3.2	PCS interfaces .....	449
32.3.3	Frame structure .....	450
32.3.4	State variables .....	450
32.3.5	State diagrams .....	452
32.3.6	PCS electrical specifications .....	453
32.4	PMA functional specifications and service interface .....	456
32.4.1	PMA functional specifications .....	456
32.4.2	PMA service interface .....	460
32.5	Management functions .....	463
32.5.1	100BASE-T2 Use of Auto-Negotiation and MII Registers 8, 9, and 10 .....	463
32.5.2	Management functions .....	464
32.5.3	PHY specific registers for 100BASE-T2 .....	465
32.5.4	Changes and additions to Auto-Negotiation (Clause 28) .....	467
32.6	PMA electrical specifications .....	470
32.6.1	PMA-to-MDI interface characteristics .....	470
32.6.2	Power consumption .....	493
32.7	Link segment characteristics .....	493
32.7.1	Cabling .....	493
32.7.2	Link transmission parameters .....	494
32.7.3	Noise .....	496
32.7.4	Installation practice .....	498
32.8	MDI specification .....	499
32.8.1	MDI connectors .....	499
32.8.2	Crossover function .....	500
32.9	System considerations .....	500
32.10	Environmental specifications .....	500
32.10.1	General safety .....	500
32.10.2	Network safety .....	500
32.10.3	Environment .....	502

32.10.4	Cabling specifications.....	502
32.11	PHY labeling.....	502
32.12	Delay constraints.....	502
32.12.1	PHY delay constraints (exposed MII) .....	502
32.12.2	DTE delay constraints (unexposed MII).....	503
32.13	Protocol implementation conformance statement (PICS) proforma for Clause 32, Physical Coding Sublayer (PCS), Physical Medium Attachment (PMA) sublayer and baseband medium, type 100BASE-T2 .....	504
32.13.1	Identification.....	504
32.13.2	Major capabilities/options.....	505
32.13.3	Compatibility considerations .....	505
32.13.4	PHY control function.....	506
32.13.5	Physical Coding Sublayer (PCS) or Physical Medium Attachment (PMA) sublayer.....	507
33.	Data Terminal Equipment (DTE) Power via Media Dependent Interface (MDI).....	525
33.1	Overview.....	525
33.1.1	Objectives .....	525
33.1.2	Compatibility considerations .....	525
33.1.3	Relationship of Power via MDI to the IEEE 802.3 Architecture .....	526
33.2	Power sourcing equipment.....	527
33.2.1	PSE location.....	527
33.2.2	PI pin assignments .....	529
33.2.3	PSE state diagrams.....	530
33.2.4	PD detection.....	535
33.2.5	PSE validation circuit .....	536
33.2.6	PSE detection of PDs.....	537
33.2.7	PSE classification of PDs .....	538
33.2.8	Power supply output .....	540
33.2.9	Power supply allocation.....	543
33.2.10	PSE power removal .....	543
33.3	Powered devices .....	546
33.3.1	PD PI.....	546
33.3.2	PD state diagram .....	546
33.3.3	PD valid and non-valid detection signatures .....	548
33.3.4	PD classifications.....	550
33.3.5	PD power .....	550
33.3.6	PD Maintain Power Signature .....	553
33.4	Additional electrical specifications.....	554
33.4.1	Isolation .....	554
33.4.2	Fault tolerance.....	555
33.4.3	Impedance balance.....	556
33.4.4	Common-mode output voltage .....	556
33.4.5	Pair-to-pair output noise voltage.....	558
33.4.6	Differential noise voltage.....	559
33.4.7	Return loss .....	559
33.4.8	Midspan PSE device additional requirements .....	560
33.5	Environmental.....	563
33.5.1	General safety .....	563
33.5.2	Network safety.....	563
33.5.3	Installation and maintenance guidelines .....	563
33.5.4	Patch panel considerations.....	563
33.5.5	Cabling resistance unbalance.....	563

33.5.6	Telephony voltages .....	564
33.5.7	Electromagnetic emissions .....	564
33.5.8	Temperature and humidity .....	564
33.5.9	Labeling .....	564
33.6	Management function requirements .....	564
33.6.1	PSE registers .....	564
33.7	Protocol implementation conformance statement (PICS) proforma for Clause 33, DTE Power via MDI .....	569
33.7.1	Introduction .....	569
33.7.2	Identification .....	569
33.7.3	PICS proforma tables for DTE Power via MDI .....	571
Annex 22A (informative)	MII output delay, setup, and hold time budget .....	583
Annex 22B (informative)	MII driver ac characteristics .....	586
Annex 22C (informative)	Measurement techniques for MII signal timing characteristics .....	588
Annex 22D (informative)	Clause 22 access to Clause 45 MMD registers .....	591
Annex 23A (normative)	6T codewords .....	593
Annex 23B (informative)	Noise budget .....	595
Annex 23C (informative)	Use of cabling systems with a nominal differential characteristic impedance of 120 $\Omega$ .....	596
Annex 27A (normative)	Repeater delay consistency requirements .....	597
Annex 28A (normative)	Selector Field definitions .....	599
Annex 28B (normative)	IEEE 802.3 Selector base page definition .....	600
Annex 28C (normative)	Next page Message Code field definitions .....	603
Annex 28D (normative)	Description of extensions to Clause 28 and associated annexes .....	607
Annex 29A (informative)	DTE and repeater delay components .....	611
Annex 29B (informative)	Recommended topology documentation .....	612
Annex 30A (normative)	GDMO specification for IEEE 802.3 managed object classes .....	613
Annex 30B (normative)	GDMO and ASN.1 definitions for management .....	723
Annex 31A (normative)	MAC Control opcode assignments .....	737
Annex 31B (normative)	MAC Control PAUSE operation .....	741
Annex 32A (informative)	Use of cabling systems with nominal differential characteristic impedance of 120 $\Omega$ or 150 $\Omega$ .....	753
Annex 33A (informative)	PSE detection of PDs .....	755

Annex 33B (informative) Cabling guidelines.....	758
Annex 33C (informative) Recommended test configurations and procedures.....	759
Annex 33D (informative) PSE-PD stability .....	786
Annex 33E (informative) Cabling resistance unbalance .....	789

### SECTION THREE

34.	Introduction to 1000 Mb/s baseband network .....	1
34.1	Overview.....	1
34.1.1	Reconciliation Sublayer (RS) and Gigabit Media Independent Interface (GMII)..	1
34.1.2	Physical Layer signaling systems .....	2
34.1.3	Repeater .....	2
34.1.4	Auto-Negotiation, type 1000BASE-X.....	2
34.1.5	Auto-Negotiation, type 1000BASE-T .....	3
34.1.6	Management.....	3
34.2	State diagrams.....	3
34.3	Protocol implementation conformance statement (PICS) proforma.....	3
34.4	Relation of Gigabit Ethernet to other standards.....	3
35.	Reconciliation Sublayer (RS) and Gigabit Media Independent Interface (GMII).....	5
35.1	Overview.....	5
35.1.1	Summary of major concepts .....	6
35.1.2	Application.....	6
35.1.3	Rate of operation.....	6
35.1.4	Allocation of functions .....	6
35.2	Functional specifications .....	6
35.2.1	Mapping of GMII signals to PLS service primitives and Station Management.....	7
35.2.2	GMII signal functional specifications.....	10
35.2.3	GMII data stream .....	18
35.2.4	MAC delay constraints (with GMII) .....	21
35.2.5	Management functions.....	21
35.3	Signal mapping .....	21
35.4	Electrical characteristics .....	22
35.4.1	DC characteristics .....	22
35.4.2	AC characteristics .....	22
35.5	Protocol implementation conformance statement (PICS) proforma for Clause 35, Reconciliation Sublayer (RS) and Gigabit Media Independent Interface (GMII).....	27
35.5.1	Introduction.....	27
35.5.2	Identification.....	27
35.5.3	PICS proforma tables for reconciliation sublayer and Gigabit Media Independent Interface .....	28
36.	Physical Coding Sublayer (PCS) and Physical Medium Attachment (PMA) sublayer, type 1000BASE-X.....	33
36.1	Overview.....	33
36.1.1	Scope.....	33
36.1.2	Objectives .....	33
36.1.3	Relationship of 1000BASE-X to other standards.....	33
36.1.4	Summary of 1000BASE-X sublayers .....	34
36.1.5	Inter-sublayer interfaces .....	34
36.1.6	Functional block diagram .....	35
36.1.7	State diagram conventions.....	35
36.2	Physical Coding Sublayer (PCS).....	36
36.2.1	PCS Interface (GMII) .....	36
36.2.2	Functions within the PCS .....	37

36.2.3	Use of code-groups .....	37
36.2.4	8B/10B transmission code .....	37
36.2.5	Detailed functions and state diagrams .....	50
36.3	Physical Medium Attachment (PMA) sublayer .....	64
36.3.1	Service Interface .....	64
36.3.2	Functions within the PMA .....	65
36.3.3	A physical instantiation of the PMA Service Interface .....	66
36.3.4	General electrical characteristics of the TBI .....	69
36.3.5	TBI transmit interface electrical characteristics .....	71
36.3.6	TBI receive interface electrical characteristics .....	71
36.3.7	Loopback mode .....	72
36.3.8	Test functions .....	73
36.4	Compatibility considerations .....	73
36.5	Delay constraints .....	73
36.5.1	MDI to GMII delay constraints .....	74
36.5.2	DTE delay constraints (half duplex mode) .....	74
36.5.3	Carrier de-assertion/assertion constraint (half duplex mode) .....	75
36.6	Environmental specifications .....	75
36.7	Protocol implementation conformance statement (PICS) proforma for Clause 36, Physical Coding Sublayer (PCS) and Physical Medium Attachment (PMA) sublayer, type 1000BASE-X .....	75
36.7.1	Introduction .....	75
36.7.2	Identification .....	76
36.7.3	Major Capabilities/Options .....	77
36.7.4	PICS proforma tables for the PCS and PMA sublayer, type 1000BASE-X .....	77
37.	Auto-Negotiation function, type 1000BASE-X .....	81
37.1	Overview .....	81
37.1.1	Scope .....	81
37.1.2	Application perspective/objectives .....	81
37.1.3	Relationship to ISO/IEC 8802-3 .....	82
37.1.4	Compatibility considerations .....	82
37.2	Functional specifications .....	83
37.2.1	Config_Reg encoding .....	83
37.2.2	Transmit function requirements .....	86
37.2.3	Receive function requirements .....	86
37.2.4	Arbitration process requirements .....	87
37.2.5	Management function requirements .....	91
37.2.6	Absence of management function .....	94
37.3	Detailed functions and state diagrams .....	94
37.3.1	State diagram variables .....	94
37.4	Environmental specifications .....	99
37.5	Protocol implementation conformance statement (PICS) proforma for Clause 37, Auto-Negotiation function, type 1000BASE-X .....	101
37.5.1	Introduction .....	101
37.5.2	Identification .....	101
37.5.3	Major Capabilities/Options .....	102
37.5.4	PICS proforma tables for the Auto-Negotiation function, type 1000BASE-X ..	102
38.	Physical Medium Dependent (PMD) sublayer and baseband medium, type 1000BASE-LX (long wavelength laser) and 1000BASE-SX (short wavelength laser) .....	105
38.1	Overview .....	105

38.1.1	Physical Medium Dependent (PMD) sublayer service interface.....	105
38.1.2	Medium Dependent Interface (MDI).....	106
38.2	PMD functional specifications.....	107
38.2.1	PMD block diagram.....	107
38.2.2	PMD transmit function.....	107
38.2.3	PMD receive function.....	107
38.2.4	PMD signal detect function.....	108
38.3	PMD to MDI optical specifications for 1000BASE-SX.....	108
38.3.1	Transmitter optical specifications.....	109
38.3.2	Receive optical specifications.....	110
38.3.3	Worst-case 1000BASE-SX link power budget and penalties (informative).....	110
38.4	PMD to MDI optical specifications for 1000BASE-LX.....	111
38.4.1	Transmitter optical specifications.....	111
38.4.2	Receive optical specifications.....	112
38.4.3	Worst-case 1000BASE-LX link power budget and penalties (informative).....	113
38.5	Jitter specifications for 1000BASE-SX and 1000BASE-LX.....	113
38.6	Optical measurement requirements.....	114
38.6.1	Center wavelength and spectral width measurements.....	114
38.6.2	Optical power measurements.....	114
38.6.3	Extinction ratio measurements.....	114
38.6.4	Relative Intensity Noise (RIN).....	114
38.6.5	Transmitter optical waveform (transmit eye).....	114
38.6.6	Transmit rise/fall characteristics.....	115
38.6.7	Receive sensitivity measurements.....	115
38.6.8	Total jitter measurements.....	116
38.6.9	Deterministic jitter measurement (informative).....	116
38.6.10	Coupled Power Ratio (CPR) measurements.....	116
38.6.11	Conformance test signal at TP3 for receiver testing.....	117
38.6.12	Measurement of the receiver 3 dB electrical upper cutoff frequency.....	118
38.7	Environmental specifications.....	119
38.7.1	General safety.....	119
38.7.2	Laser safety.....	119
38.7.3	Installation.....	119
38.8	Environment.....	119
38.8.1	Electromagnetic emission.....	120
38.8.2	Temperature, humidity, and handling.....	120
38.9	PMD labeling requirements.....	120
38.10	Fiber optic cabling model.....	120
38.11	Characteristics of the fiber optic cabling.....	121
38.11.1	Optical fiber and cable.....	121
38.11.2	Optical fiber connection.....	122
38.11.3	Medium Dependent Interface (MDI).....	122
38.11.4	Single-mode fiber offset-launch mode-conditioning patch cord for MMF operation of 1000BASE-LX.....	123
38.12	Protocol implementation conformance statement (PICS) proforma for Clause 38, Physical Medium Dependent (PMD) sublayer and baseband medium, type 1000BASE-LX (Long Wavelength Laser) and 1000BASE-SX (Short Wavelength Laser).....	125
38.12.1	Introduction.....	125
38.12.2	Identification.....	125
38.12.3	Major capabilities/options.....	126
38.12.4	PICS proforma tables for Physical Medium Dependent (PMD) sublayer and baseband medium, type 1000BASE-LX (Long Wavelength Laser) and 1000BASE-SX (Short Wavelength Laser).....	127

39.	Physical Medium Dependent (PMD) sublayer and baseband medium, type 1000BASE-CX (short-haul copper).....	133
39.1	Overview.....	133
39.2	Functional specifications .....	133
39.2.1	PMD transmit function .....	133
39.2.2	PMD receive function.....	133
39.2.3	PMD signal detect function .....	133
39.3	PMD to MDI electrical specifications .....	134
39.3.1	Transmitter electrical specifications .....	135
39.3.2	Receiver electrical specifications.....	137
39.3.3	Jitter specifications for 1000BASE-CX.....	138
39.4	Jumper cable assembly characteristics .....	139
39.4.1	Compensation networks.....	139
39.4.2	Shielding .....	139
39.5	MDI specification .....	139
39.5.1	MDI connectors .....	140
39.5.2	Crossover function.....	142
39.6	Electrical measurement requirements.....	143
39.6.1	Transmit rise/fall time.....	143
39.6.2	Transmit skew measurement .....	143
39.6.3	Transmit eye (normalized and absolute).....	143
39.6.4	Through_connection impedance.....	143
39.6.5	Jumper cable intra-pair differential skew .....	143
39.6.6	Receiver link signal .....	144
39.6.7	Near-End Cross Talk (NEXT).....	144
39.6.8	Differential time-domain reflectometry (TDR) measurement procedure.....	144
39.7	Environmental specifications.....	145
39.8	Protocol implementation conformance statement (PICS) proforma for Clause 39, Physical Medium Dependent (PMD) sublayer and baseband medium, type 1000BASE-CX.....	146
39.8.1	Introduction.....	146
39.8.2	Identification.....	146
39.8.3	Major capabilities/options.....	147
39.8.4	PICS proforma tables for Physical Medium Dependent (PMD) sublayer and baseband medium, type 1000BASE-CX (short-haul copper).....	147
40.	Physical Coding Sublayer (PCS), Physical Medium Attachment (PMA) sublayer and baseband medium, type 1000BASE-T .....	151
40.1	Overview.....	151
40.1.1	Objectives .....	151
40.1.2	Relationship of 1000BASE-T to other standards .....	151
40.1.3	Operation of 1000BASE-T .....	151
40.1.4	Signaling .....	156
40.1.5	Inter-sublayer interfaces .....	156
40.1.6	Conventions in this clause .....	156
40.2	1000BASE-T Service Primitives and Interfaces .....	157
40.2.1	Technology-Dependent Interface .....	157
40.2.2	PMA Service Interface.....	158
40.2.3	PMA_TXMODE.indication.....	159
40.2.4	PMA_CONFIG.indication.....	160
40.2.5	PMA_UNITDATA.request.....	160
40.2.6	PMA_UNITDATA.indication .....	161
40.2.7	PMA_SCRSTATUS.request.....	162



40.2.8	PMA_RXSTATUS.indication .....	162
40.2.9	PMA_REMRXSTATUS.request .....	163
40.2.10	PMA_RESET.indication .....	163
40.3	Physical Coding Sublayer (PCS) .....	163
40.3.1	PCS functions .....	164
40.3.2	Stream structure .....	179
40.3.3	State variables .....	179
40.3.4	State diagrams .....	183
40.4	Physical Medium Attachment (PMA) sublayer .....	188
40.4.1	PMA functional specifications .....	188
40.4.2	PMA functions .....	189
40.4.3	MDI .....	191
40.4.4	Automatic MDI/MDI-X Configuration .....	192
40.4.5	State variables .....	192
40.4.6	State Diagrams .....	195
40.5	Management interface .....	197
40.5.1	Support for Auto-Negotiation .....	197
40.5.2	MASTER-SLAVE configuration resolution .....	201
40.6	PMA electrical specifications .....	203
40.6.1	PMA-to-MDI interface tests .....	203
40.7	Link segment characteristics .....	225
40.7.1	Cabling system characteristics .....	225
40.7.2	Link transmission parameters .....	225
40.7.3	Coupling parameters .....	226
40.7.4	Delay .....	227
40.7.5	Noise environment .....	227
40.7.6	External coupled noise .....	228
40.8	MDI specification .....	228
40.8.1	MDI connectors .....	228
40.8.2	Crossover function .....	229
40.8.3	MDI electrical specifications .....	230
40.9	Environmental specifications .....	232
40.9.1	General safety .....	232
40.9.2	Network safety .....	232
40.9.3	Environment .....	233
40.10	PHY labeling .....	233
40.11	Delay constraints .....	234
40.11.1	MDI to GMII delay constraints .....	234
40.11.2	DTE delay constraints (half duplex only) .....	234
40.11.3	Carrier de-assertion/assertion constraint (half duplex mode) .....	235
40.12	Protocol implementation conformance statement (PICS) proforma for Clause 40—Physical coding sublayer (PCS), physical medium attachment (PMA) sublayer and baseband medium, type 1000BASE-T .....	236
40.12.1	Identification .....	236
40.12.2	Major capabilities/options .....	236
40.12.3	Clause conventions .....	237
40.12.4	Physical Coding Sublayer (PCS) .....	237
40.12.5	Physical Medium Attachment (PMA) .....	241
40.12.6	Management interface .....	242
40.12.7	PMA Electrical Specifications .....	244
40.12.8	Characteristics of the link segment .....	250
40.12.9	MDI requirements .....	251
40.12.10	General safety and environmental requirements .....	253
40.12.11	Timing requirements .....	253

41.	Repeater for 1000 Mb/s baseband networks.....	255
41.1	Overview.....	255
41.1.1	Scope.....	255
41.1.2	Application perspective.....	256
41.1.3	Relationship to PHY.....	256
41.2	Repeater functional specifications.....	256
41.2.1	Repeater functions.....	257
41.2.2	Detailed repeater functions and state diagrams.....	261
41.3	Repeater electrical specifications.....	269
41.3.1	Electrical isolation.....	269
41.4	Environmental specifications.....	269
41.4.1	General safety.....	269
41.4.2	Network safety.....	269
41.4.3	Electrical isolation.....	270
41.4.4	Reliability.....	270
41.4.5	Environment.....	271
41.5	Repeater labeling.....	271
41.6	Protocol implementation conformance statement (PICS) proforma for Clause 41, Repeater for 1000 Mb/s baseband networks.....	271
41.6.1	Introduction.....	271
41.6.2	Identification.....	272
41.6.3	Major capabilities/options.....	272
41.6.4	PICS proforma tables for the Repeater for 1000 Mb/s baseband networks.....	273
42.	System considerations for multisegment 1000 Mb/s networks.....	281
42.1	Overview.....	281
42.1.1	Single collision domain multisegment networks.....	282
42.1.2	Repeater usage.....	283
42.2	Transmission System Model 1.....	283
42.3	Transmission System Model 2.....	283
42.3.1	Round-trip collision delay.....	284
42.4	Full duplex 1000 Mb/s topology limitations.....	287
43.	Content moved to IEEE Std 802.1AX-2008.....	289
	Annex 36A (informative) Jitter test patterns.....	291
	36A.1 High-frequency test pattern.....	291
	36A.2 Low-frequency test pattern.....	291
	36A.3 Mixed frequency test pattern.....	291
	36A.4 Long continuous random test pattern.....	291
	36A.5 Short continuous random test pattern.....	292
	Annex 36B (informative) 8B/10B transmission code running disparity calculation examples.....	294
	Annex 38A (informative) Fiber launch conditions.....	297
	38A.1 Overfilled Launch.....	297
	38A.2 Radial Overfilled Launch (ROFL).....	297
	Annex 40A (informative) Additional cabling design guidelines.....	299

40A.1 Alien crosstalk .....	299
40A.2 Cabling configurations.....	299
Annex 40B (informative) Description of cable clamp.....	301
40B.1 Cable clamp validation .....	303
Annex 40C (informative) Add-on interface for additional Next Pages.....	305
40C.1 State variables .....	307
40C.2 State diagrams.....	307
Annex 43A Annex 43A is no longer in use. ....	313
Annex 43B Annex 43B is no longer in use. ....	314
Annex 43C Annex 43C is no longer in use. ....	315

## SECTION FOUR

44.	Introduction to 10 Gb/s baseband network .....	1
44.1	Overview.....	1
44.1.1	Scope.....	1
44.1.2	Objectives .....	1
44.1.3	Relationship of 10 Gigabit Ethernet to the ISO OSI reference model.....	2
44.1.4	Summary of 10 Gigabit Ethernet sublayers .....	3
44.1.5	Management.....	4
44.2	State diagrams.....	4
44.3	Delay constraints.....	4
44.4	Protocol implementation conformance statement (PICS) proforma.....	6
44.5	Relation of 10 Gigabit Ethernet to other standards.....	6
45.	Management Data Input/Output (MDIO) Interface .....	9
45.1	Overview.....	9
45.1.1	Summary of major concepts .....	9
45.1.2	Application.....	9
45.2	MDIO Interface Registers.....	10
45.2.1	PMA/PMD registers .....	14
45.2.2	WIS registers.....	77
45.2.3	PCS registers .....	92
45.2.4	PHY XS registers.....	112
45.2.5	DTE XS registers .....	120
45.2.6	TC registers.....	127
45.2.7	Auto-Negotiation registers.....	135
45.2.8	Clause 22 extension registers.....	147
45.2.9	Vendor specific MMD 1 registers .....	149
45.2.10	Vendor specific MMD 2 registers .....	151
45.3	Management frame structure .....	152
45.3.1	IDLE (idle condition).....	153
45.3.2	PRE (preamble).....	153
45.3.3	ST (start of frame).....	153
45.3.4	OP (operation code).....	153
45.3.5	PRTAD (port address) .....	153
45.3.6	DEVAD (device address) .....	153
45.3.7	TA (turnaround).....	153
45.3.8	ADDRESS / DATA .....	154
45.4	Electrical interface .....	154
45.4.1	Electrical specification.....	154
45.4.2	Timing specification .....	154
45.5	Protocol implementation conformance statement (PICS) proforma for Clause 45, MDIO interface .....	156
45.5.1	Introduction.....	156
45.5.2	Identification .....	156
45.5.3	PICS proforma tables for the Management Data Input Output (MDIO) interface .....	157
46.	Reconciliation Sublayer (RS) and 10 Gigabit Media Independent Interface (XGMII).....	187
46.1	Overview.....	187

46.1.1	Summary of major concepts .....	188
46.1.2	Application.....	188
46.1.3	Rate of operation.....	188
46.1.4	Delay constraints.....	188
46.1.5	Allocation of functions .....	189
46.1.6	XGMII structure .....	189
46.1.7	Mapping of XGMII signals to PLS service primitives .....	190
46.2	XGMII data stream .....	192
46.2.1	Inter-frame <inter-frame>.....	193
46.2.2	Preamble <preamble> and start of frame delimiter <sfd>.....	193
46.2.3	Data <data>.....	194
46.2.4	End of frame delimiter <efd> .....	194
46.2.5	Definition of Start of Packet and End of Packet Delimiters .....	194
46.3	XGMII functional specifications .....	194
46.3.1	Transmit.....	194
46.3.2	Receive.....	197
46.3.3	Error and fault handling.....	199
46.3.4	Link fault signaling.....	200
46.4	XGMII electrical characteristics.....	203
46.5	Protocol implementation conformance statement (PICS) proforma for Clause 46, Reconciliation Sublayer (RS) and 10 Gigabit Media Independent Interface (XGMII).....	205
46.5.1	Introduction.....	205
46.5.2	Identification.....	205
46.5.3	PICS proforma Tables for Reconciliation Sublayer and 10 Gigabit Media Independent Interface .....	206
47.	XGMII Extender Sublayer (XGXS) and 10 Gigabit Attachment Unit Interface (XAUI).....	211
47.1	Overview.....	211
47.1.1	Summary of major concepts .....	212
47.1.2	Application.....	212
47.1.3	Rate of operation.....	212
47.1.4	Allocation of functions .....	212
47.2	Functional specifications .....	212
47.2.1	PCS and PMA functionality .....	213
47.2.2	Delay constraints.....	213
47.3	XAUI Electrical characteristics .....	213
47.3.1	Signal levels.....	214
47.3.2	Signal paths.....	214
47.3.3	Driver characteristics .....	214
47.3.4	Receiver characteristics .....	216
47.3.5	Interconnect characteristics.....	218
47.4	Electrical measurement requirements.....	219
47.4.1	Compliance interconnect definition.....	219
47.4.2	Eye template measurements.....	219
47.4.3	Jitter test requirements.....	220
47.5	Environmental specifications.....	220
47.6	Protocol implementation conformance statement (PICS) proforma for Clause 47, XGMII Extender (XGMII) and 10 Gigabit Attachment Unit Interface (XAUI).....	221
47.6.1	Introduction.....	221
47.6.2	Identification.....	221
47.6.3	Major capabilities/options.....	222
47.6.4	PICS Proforma tables for XGXS and XAUI .....	222

48.	Physical Coding Sublayer (PCS) and Physical Medium Attachment (PMA) sublayer, type 10GBASE-X .....	225
48.1	Overview .....	225
48.1.1	Objectives .....	225
48.1.2	Relationship of 10GBASE-X to other standards .....	226
48.1.3	Summary of 10GBASE-X sublayers .....	226
48.1.4	Rate of operation.....	227
48.1.5	Allocation of functions .....	227
48.1.6	Inter-sublayer interfaces .....	227
48.1.7	Functional block diagram .....	228
48.1.8	Special symbols .....	228
48.2	Physical Coding Sublayer (PCS) .....	229
48.2.1	PCS service interface (XGMII) .....	229
48.2.2	Functions within the PCS .....	229
48.2.3	Use of code-groups .....	230
48.2.4	Ordered_sets and special code-groups.....	232
48.2.5	Management function requirements .....	237
48.2.6	Detailed functions and state diagrams .....	238
48.2.7	Auto-Negotiation for Backplane Ethernet .....	250
48.3	Physical Medium Attachment (PMA) sublayer.....	250
48.3.1	Functions within the PMA .....	250
48.3.2	Service interface .....	251
48.3.3	Loopback mode.....	252
48.3.4	Test functions.....	253
48.4	Compatibility considerations .....	253
48.5	Delay constraints.....	253
48.6	Environmental specifications.....	253
48.7	Protocol implementation conformance statement (PICS) proforma for Physical Coding Sublayer (PCS) and Physical Medium Attachment (PMA) sublayer, type 10GBASE-X..	254
48.7.1	Introduction.....	254
48.7.2	Identification.....	254
48.7.3	Major capabilities/options.....	255
48.7.4	PICS proforma tables for the PCS and PMA sublayer, type 10GBASE-X.....	255
49.	Physical Coding Sublayer (PCS) for 64B/66B, type 10GBASE-R .....	257
49.1	Overview .....	257
49.1.1	Scope.....	257
49.1.2	Objectives .....	257
49.1.3	Relationship of 10GBASE-R to other standards .....	257
49.1.4	Summary of 10GBASE-R and 10GBASE-W sublayers .....	258
49.1.5	Inter-sublayer interfaces .....	260
49.1.6	Functional block diagram .....	261
49.2	Physical Coding Sublayer (PCS) .....	262
49.2.1	PCS service interface (XGMII) .....	262
49.2.2	Functions within the PCS .....	262
49.2.3	Use of blocks .....	263
49.2.4	64B/66B transmission code .....	263
49.2.5	Transmit process .....	268
49.2.6	Scrambler .....	269
49.2.7	Gearbox.....	269
49.2.8	Test-pattern generators .....	269
49.2.9	Block synchronization .....	270

49.2.10	Descrambler .....	271
49.2.11	Receive process.....	271
49.2.12	Test-pattern checker.....	271
49.2.13	Detailed functions and state diagrams .....	272
49.2.14	PCS Management .....	276
49.2.15	Delay constraints.....	277
49.2.16	Auto-Negotiation for Backplane Ethernet .....	278
49.3	Protocol implementation conformance statement (PICS) proforma for Clause 49, Physical Coding Sublayer (PCS) type 10GBASE-R.....	281
49.3.1	Introduction.....	281
49.3.2	Identification.....	281
49.3.3	Major Capabilities/Options.....	282
49.3.4	PICS Proforma Tables for PCS, type 10GBASE-R .....	282
49.3.5	Test-pattern modes.....	283
49.3.6	Management.....	284
50.	WAN Interface Sublayer (WIS), type 10GBASE-W .....	287
50.1	Overview.....	287
50.1.1	Scope.....	287
50.1.2	Objectives .....	288
50.1.3	Relationship to other sublayers.....	288
50.1.4	Summary of functions.....	289
50.1.5	Sublayer interfaces.....	289
50.1.6	Functional block diagram .....	290
50.1.7	Notational conventions .....	290
50.2	WIS Service Interface.....	290
50.2.1	WIS_UNITDATA.request.....	291
50.2.2	WIS_UNITDATA.indication .....	291
50.2.3	WIS_SIGNAL.request.....	292
50.2.4	WIS_SIGNAL.indication .....	292
50.3	Functions within the WIS .....	293
50.3.1	Payload mapping and data-unit delineation.....	294
50.3.2	WIS frame generation.....	296
50.3.3	Scrambling.....	302
50.3.4	Octet and frame delineation .....	303
50.3.5	Error propagation.....	303
50.3.6	Mapping between WIS and PMA.....	304
50.3.7	WIS data delay constraints .....	305
50.3.8	WIS test-pattern generator and checker.....	306
50.3.9	Loopback .....	309
50.3.10	Link status.....	309
50.3.11	Management interface.....	309
50.4	Synchronization state diagram.....	311
50.4.1	State diagram variables.....	311
50.4.2	State diagram .....	313
50.4.3	Parameter values .....	315
50.5	Environmental specifications.....	315
50.6	Protocol implementation conformance statement (PICS) proforma for Clause 50, WAN Interface Sublayer (WIS), type 10GBASE-W .....	317
50.6.1	Introduction.....	317
50.6.2	Identification.....	317
50.6.3	Major capabilities/options.....	318
50.6.4	PICS proforma tables for the WAN Interface Sublayer (WIS), type	

	10GBASE-W .....	318
51.	Physical Medium Attachment (PMA) sublayer, type Serial.....	323
51.1	Overview.....	323
51.1.1	Scope.....	323
51.1.2	Summary of functions.....	323
51.2	PMA Service Interface.....	324
51.2.1	PMA_UNITDATA.request.....	324
51.2.2	PMA_UNITDATA.indication.....	325
51.2.3	PMA_SIGNAL.indication.....	325
51.3	Functions within the PMA.....	325
51.3.1	PMA transmit function.....	326
51.3.2	PMA receive function.....	326
51.3.3	Delay Constraints.....	326
51.4	Sixteen-Bit Interface (XSBI).....	326
51.4.1	Required signals.....	328
51.4.2	Optional Signals.....	330
51.5	General electrical characteristics of the XSBI.....	330
51.5.1	DC characteristics.....	330
51.5.2	Valid signal levels.....	330
51.5.3	Rise and fall time definition.....	330
51.5.4	Output load.....	332
51.6	XSBI transmit interface electrical characteristics.....	332
51.6.1	XSBI transmit interface timing.....	332
51.6.2	XSBI PMA_TX_CLK and PMA_TXCLK_SRC Specification.....	334
51.7	XSBI receive interface electrical characteristics.....	334
51.7.1	XSBI receive interface timing.....	334
51.7.2	XSBI PMA_RX_CLK specification.....	336
51.8	PMA loopback mode (optional).....	336
51.9	Environmental specifications.....	337
51.10	Protocol implementation conformance statement (PICS) proforma for Clause 51, Physical Medium Attachment (PMA) sublayer, type Serial.....	338
51.10.1	Introduction.....	338
51.10.2	Identification.....	338
51.10.3	Major capabilities/options.....	339
51.10.4	PICS proforma tables for the PMA Interface Sublayer, type Serial.....	339
52.	Physical Medium Dependent (PMD) sublayer and baseband medium, type 10GBASE-S (short wavelength serial), 10GBASE-L (long wavelength serial), and 10GBASE-E (extra long wavelength serial).....	341
52.1	Overview.....	341
52.1.1	Physical Medium Dependent (PMD) sublayer service interface.....	342
52.2	Delay constraints.....	344
52.3	PMD MDIO function mapping.....	344
52.4	PMD functional specifications.....	345
52.4.1	PMD block diagram.....	345
52.4.2	PMD Transmit function.....	345
52.4.3	PMD Receive function.....	345
52.4.4	PMD Signal Detect function.....	345
52.4.5	PMD_reset function.....	346
52.4.6	PMD_fault function.....	346
52.4.7	PMD_global_transmit_disable function.....	346



52.4.8	PMD_transmit_fault function.....	347
52.4.9	PMD_receive_fault function.....	347
52.5	PMD to MDI optical specifications for 10GBASE-S.....	347
52.5.1	10GBASE-S transmitter optical specifications.....	348
52.5.2	10GBASE-S receive optical specifications.....	350
52.5.3	10GBASE-S link power budgets (informative).....	350
52.6	PMD to MDI optical specifications for 10GBASE-L.....	351
52.6.1	10GBASE-L transmitter optical specifications.....	351
52.6.2	10GBASE-L receive optical specifications.....	353
52.6.3	10GBASE-L link power budgets (informative).....	353
52.7	PMD to MDI optical specifications for 10GBASE-E.....	354
52.7.1	10GBASE-E transmitter optical specifications.....	355
52.7.2	10GBASE-E receive optical specifications.....	356
52.7.3	10GBASE-E link power budgets (informative).....	356
52.8	Jitter specifications for 10GBASE-R and 10GBASE-W.....	356
52.8.1	Sinusoidal jitter for receiver conformance test.....	357
52.9	Optical measurement requirements.....	358
52.9.1	Test patterns.....	358
52.9.2	Center wavelength and spectral width measurements.....	360
52.9.3	Average optical power measurements.....	360
52.9.4	Extinction ratio measurements.....	360
52.9.5	Optical modulation amplitude (OMA) test procedure.....	360
52.9.6	Relative intensity noise optical modulation amplitude (RINxOMA) measuring procedure.....	361
52.9.7	Transmitter optical waveform.....	363
52.9.8	Receiver sensitivity measurements.....	364
52.9.9	Stressed receiver conformance test.....	365
52.9.10	Transmitter and dispersion penalty measurement.....	370
52.9.11	Measurement of the receiver 3 dB electrical upper cutoff frequency.....	372
52.10	Environmental specifications.....	373
52.10.1	General safety.....	373
52.10.2	Laser safety.....	373
52.10.3	Installation.....	373
52.11	Environment.....	373
52.11.1	Electromagnetic emission.....	373
52.11.2	Temperature, humidity, and handling.....	374
52.12	PMD labeling requirements.....	374
52.13	Fiber optic cabling model.....	374
52.14	Characteristics of the fiber optic cabling (channel).....	375
52.14.1	Optical fiber and cable.....	375
52.14.2	Optical fiber connection.....	375
52.14.3	10GBASE-E attenuator management.....	376
52.14.4	Medium Dependent Interface (MDI) requirements.....	377
52.15	Protocol implementation conformance statement (PICS) proforma for Clause 52, Physical Medium Dependent (PMD) sublayer and baseband medium, type 10GBASE-S (short wavelength serial), 10GBASE-L (long wavelength serial), and 10GBASE-E (extra long wavelength serial).....	378
52.15.1	Introduction.....	378
52.15.2	Identification.....	378
52.15.3	PICS proforma tables for Physical Medium Dependent (PMD) sublayer and baseband medium, types 10GBASE-R and 10GBASE-W.....	380
53.	Physical Medium Dependent (PMD) sublayer and baseband medium, type 10GBASE-LX4.....	385

53.1	Overview.....	385
53.1.1	Physical Medium Dependent (PMD) service interface .....	385
53.1.2	PMD_UNITDATA.request.....	385
53.1.3	PMD_UNITDATA.indication .....	386
53.1.4	PMD_SIGNAL.indication .....	387
53.2	Delay constraints.....	387
53.3	PMD MDIO function mapping.....	387
53.4	PMD functional specifications.....	388
53.4.1	PMD block diagram.....	388
53.4.2	PMD transmit function .....	389
53.4.3	PMD receive function.....	390
53.4.4	Global PMD signal detect function .....	390
53.4.5	PMD lane by lane signal detect function .....	390
53.4.6	PMD reset function .....	391
53.4.7	Global PMD transmit disable function .....	391
53.4.8	PMD lane by lane transmit disable function.....	391
53.4.9	PMD fault function .....	391
53.4.10	PMD transmit fault function (optional) .....	391
53.4.11	PMD receive fault function (optional).....	391
53.5	Wavelength-division multiplexed-lane assignments .....	391
53.6	Operating ranges for 10GBASE-LX4 PMD.....	391
53.7	PMD to MDI optical specifications for 10GBASE-LX4.....	392
53.7.1	Transmitter optical specifications.....	392
53.7.2	Receive optical specifications.....	394
53.7.3	Worst case 10GBASE-LX4 link power budget and penalties (informative).....	394
53.8	Jitter specifications for each lane of the 10GBASE-LX4 PMD .....	394
53.8.1	Transmit jitter specification.....	394
53.8.2	Receive jitter tolerance specification.....	396
53.9	Optical measurement requirements .....	398
53.9.1	Wavelength range measurements .....	398
53.9.2	Optical power measurements.....	399
53.9.3	Source spectral window measurements .....	399
53.9.4	Extinction ratio measurements.....	399
53.9.5	Optical Modulation Amplitude (OMA) measurements .....	399
53.9.6	Relative Intensity Noise [RIN <sub>12</sub> (OMA)] .....	399
53.9.7	Transmitter optical waveform (transmit eye) .....	399
53.9.8	Transmit rise/fall characteristics .....	401
53.9.9	Receive sensitivity measurements .....	401
53.9.10	Transmitter jitter conformance (per lane).....	401
53.9.11	Receive sensitivity measurements .....	403
53.9.12	Stressed receiver conformance test.....	403
53.9.13	Measurement of the receiver 3 dB electrical upper cutoff frequency.....	405
53.9.14	Conformance test signal at TP3 for receiver testing.....	406
53.9.15	Receiver test suite for WDM conformance testing.....	408
53.10	Environmental specifications.....	410
53.10.1	General safety .....	410
53.10.2	Laser safety .....	410
53.10.3	Installation .....	411
53.11	Environment.....	411
53.11.1	Electromagnetic emission .....	411
53.11.2	Temperature, humidity, and handling.....	411
53.12	PMD labeling requirements .....	411
53.13	Fiber optic cabling model .....	412
53.14	Characteristics of the fiber optic cabling (channel).....	412

53.14.1	Optical fiber and cable .....	412
53.14.2	Optical fiber connection .....	413
53.14.3	Medium Dependent Interface (MDI) .....	414
53.15	Protocol implementation conformance statement (PICS) proforma for Clause 53, Physical Medium Dependent (PMD) sublayer and baseband medium, type 10GBASE-LX4 .....	415
53.15.1	Introduction .....	415
53.15.2	Identification .....	415
53.15.3	Major capabilities/options .....	416
53.15.4	PICS proforma tables for 10GBASE-LX4 and baseband medium .....	417
54.	Physical Medium Dependent (PMD) sublayer and baseband medium, type 10GBASE-CX4 .....	425
54.1	Overview .....	425
54.2	Physical Medium Dependent (PMD) service interface .....	426
54.3	Delay constraints .....	426
54.4	PMD MDIO function mapping .....	426
54.5	PMD functional specifications .....	426
54.5.1	Link block diagram .....	426
54.5.2	PMD Transmit function .....	427
54.5.3	PMD Receive function .....	427
54.5.4	Global PMD signal detect function .....	427
54.5.5	PMD lane-by-lane signal detect function .....	428
54.5.6	Global PMD transmit disable function .....	428
54.5.7	PMD lane-by-lane transmit disable function .....	428
54.5.8	Loopback mode .....	429
54.5.9	PMD fault function .....	429
54.5.10	PMD transmit fault function .....	429
54.5.11	PMD receive fault function .....	429
54.6	MDI Electrical specifications for 10GBASE-CX4 .....	429
54.6.1	Signal levels .....	429
54.6.2	Signal paths .....	430
54.6.3	Transmitter characteristics .....	430
54.6.4	Receiver characteristics .....	436
54.7	Cable assembly characteristics .....	437
54.7.1	Characteristic impedance and reference impedance .....	438
54.7.2	Cable assembly insertion loss .....	438
54.7.3	Cable assembly return loss .....	439
54.7.4	Near-End Crosstalk (NEXT) .....	439
54.7.5	Far-End Crosstalk (FEXT) .....	441
54.7.6	Shielding .....	442
54.7.7	Crossover function .....	442
54.8	MDI specification .....	443
54.8.1	MDI connectors .....	443
54.8.2	Connector pin assignments .....	444
54.9	Environmental specifications .....	444
54.10	Protocol implementation conformance statement (PICS) proforma for Clause 54, Physical Medium Dependent (PMD) sublayer and baseband medium, type 10GBASE-CX4 .....	445
54.10.1	Introduction .....	445
54.10.2	Identification .....	445
54.10.3	PICS proforma tables for 10GBASE-CX4 and baseband medium .....	446
54.10.4	Major capabilities/options .....	446
55.	Physical Coding Sublayer (PCS), Physical Medium Attachment (PMA) sublayer and baseband medium, type 10GBASE-T .....	453

55.1	Overview .....	453
55.1.1	Objectives .....	453
55.1.2	Relationship of 10GBASE-T to other standards .....	454
55.1.3	Operation of 10GBASE-T .....	454
55.1.4	Signaling .....	458
55.1.5	Interfaces .....	458
55.1.6	Conventions in this clause .....	458
55.2	10GBASE-T service primitives and interfaces .....	459
55.2.1	Technology Dependent Interface .....	459
55.2.2	PMA service interface .....	460
55.3	Physical Coding Sublayer (PCS) .....	465
55.3.1	PCS service interface (XGMII) .....	465
55.3.2	PCS functions .....	465
55.3.3	Test-pattern generators .....	479
55.3.4	PMA training side-stream scrambler polynomials .....	479
55.3.5	Detailed functions and state diagrams .....	481
55.3.6	PCS management .....	484
55.4	Physical Medium Attachment (PMA) sublayer .....	488
55.4.1	PMA functional specifications .....	488
55.4.2	PMA functions .....	489
55.4.3	MDI .....	499
55.4.4	Automatic MDI/MDI-X configuration .....	500
55.4.5	State variables .....	501
55.4.6	State diagrams .....	505
55.5	PMA electrical specifications .....	508
55.5.1	Isolation requirement .....	508
55.5.2	Test modes .....	509
55.5.3	Transmitter electrical specifications .....	512
55.5.4	Receiver electrical specifications .....	514
55.6	Management interfaces .....	516
55.6.1	Support for Auto-Negotiation .....	516
55.6.2	MASTER-SLAVE configuration resolution .....	519
55.7	Link segment characteristics .....	521
55.7.1	Cabling system characteristics .....	521
55.7.2	Link segment transmission parameters .....	521
55.7.3	Coupling parameters between link segments .....	526
55.7.4	Noise environment .....	536
55.8	MDI specification .....	537
55.8.1	MDI connectors .....	537
55.8.2	MDI electrical specifications .....	538
55.9	Environmental specifications .....	541
55.9.1	General safety .....	541
55.9.2	Network safety .....	541
55.9.3	Installation and maintenance guidelines .....	541
55.9.4	Telephone voltages .....	541
55.9.5	Electromagnetic compatibility .....	542
55.9.6	Temperature and humidity .....	542
55.10	PHY labeling .....	542
55.11	Delay constraints .....	542
55.12	Protocol implementation conformance statement (PICS) proforma for Clause 55—Physical Coding Sublayer (PCS), Physical Medium Attachment (PMA) sublayer and baseband medium, type 10GBASE-T .....	543
55.12.1	Identification .....	543
55.12.2	Major capabilities/options .....	543

55.12.3	Physical Coding Sublayer (PCS)	544
55.12.4	Physical Medium Attachment (PMA)	545
55.12.5	Management interface	546
55.12.6	PMA Electrical Specifications	548
55.12.7	Characteristics of the link segment	549
55.12.8	MDI requirements	549
55.12.9	General safety and environmental requirements	550
55.12.10	Timing requirements	550
Annex 44A (informative) Diagram of Data Flow		551
44A.1	10GBASE-R bit ordering	551
44A.2	10GBASE-W serial bit ordering	551
44A.3	10GBASE-LX4 bit ordering	551
44A.4	Loopback locations	557
Annex 45A (informative) Clause 45 MDIO electrical interface		559
45A.1	MDIO driver	559
45A.2	Single Clause 45 electrical interface	559
45A.3	Clause 45 electrical interface for STA with Clause 22 electrical interface to PHYs	560
45A.4	Clause 22 electrical interface for STA with Clause 45 electrical interface to MMDs	560
Annex 48A Jitter test patterns		563
48A.1	High-frequency test pattern	563
48A.2	Low-frequency test pattern	563
48A.3	Mixed-frequency test pattern	563
48A.4	Continuous random test pattern (CRPAT)	564
48A.5	Continuous jitter test pattern (CJPAT)	565
48A.5.1	Continuous jitter test pattern (CJPAT) 10 bit values	566
Annex 48B (informative) Jitter test methods		571
48B.1	BER and jitter model	571
48B.2	Jitter tolerance test methodologies	574
48B.3	Jitter output test methodologies	575
Annex 50A (informative) Thresholds for Severely Errored Second calculations		581
50A.1	Section SES threshold	581
50A.2	Line SES threshold	581
50A.3	Path SES threshold	581
50A.4	Definition of Path Block Error	582
50A.5	Definition of Far End Path Block Error	582
Annex 55A (normative) LDPC details		583
55A.1	The generator matrix	583
55A.2	The sparse parity check matrix H	583
Annex 55B (informative) Additional cabling design guidelines for 10GBASE-T		584
55B.1	Alien crosstalk considerations	584



## SECTION FIVE

56.	Introduction to Ethernet for subscriber access networks .....	1
56.1	Overview .....	1
56.1.1	Summary of P2P sublayers .....	1
56.1.2	Summary of P2MP sublayers .....	2
56.1.2.1	Multipoint MAC Control Protocol (MPCP) .....	2
56.1.2.2	Reconciliation Sublayer (RS) and media independent interfaces .....	2
56.1.3	Physical Layer signaling systems .....	3
56.1.4	Management .....	5
56.1.5	Unidirectional transmission .....	6
56.2	State diagrams .....	6
56.3	Protocol implementation conformance statement (PICS) proforma .....	6
57.	Operations, Administration, and Maintenance (OAM) .....	7
57.1	Overview .....	7
57.1.1	Scope .....	7
57.1.2	Summary of objectives and major concepts .....	7
57.1.3	Summary of non-objectives .....	8
57.1.4	Positioning of OAM within the IEEE 802.3 architecture .....	8
57.1.5	Compatibility considerations .....	8
57.1.6	State diagram conventions .....	9
57.2	Functional specifications .....	9
57.2.1	Interlayer service interfaces .....	9
57.2.2	Principles of operation .....	10
57.2.3	Instances of the MAC data service interface .....	10
57.2.4	Responsibilities of OAM client .....	10
57.2.5	OAM client interactions .....	11
57.2.6	Instances of the OAM internal service interface .....	14
57.2.7	Internal block diagram .....	14
57.2.8	OAM internal interactions .....	15
57.2.9	Modes .....	16
57.2.10	OAM events .....	17
57.2.11	OAM remote loopback .....	18
57.2.12	Unidirectional OAM operation .....	20
57.3	Detailed functions and state diagrams .....	20
57.3.1	State diagram variables .....	21
57.3.2	Control .....	25
57.3.3	Multiplexer .....	29
57.3.4	Parser .....	30
57.4	OAMPDUs .....	31
57.4.1	Ordering and representation of octets .....	31
57.4.2	Structure .....	32
57.4.3	OAMPDU descriptions .....	33
57.5	OAM TLVs .....	37
57.5.1	Parsing .....	37
57.5.2	Information TLVs .....	38
57.5.3	Link Event TLVs .....	41
57.6	Variables .....	46
57.6.1	Variable Descriptors .....	46
57.6.2	Variable Containers .....	46

57.6.3	Parsing .....	48
57.6.4	Variable Branch/Leaf examples .....	49
57.6.5	Variable Indications .....	49
57.7	Protocol implementation conformance statement (PICS) proforma for Clause 57, Operations, Administration, and Maintenance (OAM) .....	50
57.7.1	Introduction .....	50
57.7.2	Identification .....	50
57.7.3	PICS proforma tables for Operation, Administration, and Maintenance (OAM) .....	52
57.7.4	Link Event TLVs .....	56
57.7.5	Variables Descriptors and Containers .....	57
58.	Physical Medium Dependent (PMD) sublayer and medium, type 100BASE-LX10 (Long Wavelength) and 100BASE-BX10 (BiDirectional Long Wavelength) .....	59
58.1	Overview .....	59
58.1.1	Goals and objectives .....	59
58.1.2	Positioning of this PMD set within the IEEE 802.3 architecture .....	60
58.1.3	Terminology and conventions .....	60
58.1.4	Physical Medium Dependent (PMD) sublayer service interface .....	60
58.2	PMD functional specifications .....	61
58.2.1	PMD block diagram .....	62
58.2.2	PMD transmit function .....	62
58.2.3	PMD receive function .....	62
58.2.4	100BASE-LX10 and 100BASE-BX10 signal detect function .....	63
58.3	PMD to MDI optical specifications for 100BASE-LX10 .....	63
58.3.1	Transmitter optical specifications .....	63
58.3.2	Receiver optical specifications .....	64
58.4	PMD to MDI optical specifications for 100BASE-BX10 .....	65
58.4.1	Transmit optical specifications .....	65
58.4.2	Receiver optical specifications .....	66
58.5	Illustrative 100BASE-LX10 and 100BASE-BX10 channels and penalties (informative) .....	67
58.6	Jitter at TP1 and TP4 for 100BASE-LX10 and 100BASE-BX10 (informative) .....	68
58.7	Optical measurement requirements .....	68
58.7.1	Test patterns .....	69
58.7.2	Wavelength and spectral width measurements .....	71
58.7.3	Optical power measurements .....	71
58.7.4	Extinction ratio measurements .....	71
58.7.5	Optical modulation amplitude (OMA) measurements (informative) .....	72
58.7.6	OMA relationship to extinction ratio and power measurements (informative) .....	72
58.7.7	Relative intensity noise optical modulation amplitude (RINxOMA) measuring procedure .....	73
58.7.8	Transmitter optical waveform (transmit eye) .....	75
58.7.9	Transmitter and dispersion penalty (TDP) measurement .....	76
58.7.10	Receiver sensitivity measurements .....	80
58.7.11	Stressed receiver conformance test .....	80
58.7.12	Jitter measurements (informative) .....	86
58.8	Environmental, safety, and labeling .....	88
58.8.1	General safety .....	88
58.8.2	Laser safety .....	88
58.8.3	Installation .....	88
58.8.4	Environment .....	88
58.8.5	PMD labeling requirements .....	88
58.9	Characteristics of the fiber optic cabling .....	89
58.9.1	Fiber optic cabling model .....	89



58.9.2	Optical fiber and cable .....	89
58.9.3	Optical fiber connection .....	90
58.9.4	Medium Dependent Interface (MDI) .....	90
58.10	Protocol implementation conformance statement (PICS) proforma for Clause 58, Physical Medium Dependent (PMD) sublayer and medium, type 100BASE-LX10 (Long Wavelength) and 100BASE-BX10 (BiDirectional Long Wavelength) .....	91
58.10.1	Introduction .....	91
58.10.2	Identification .....	91
58.10.3	PICS proforma tables for Physical Medium Dependent (PMD) sublayer and medium, type 100BASE-LX10 and 100BASE-BX10 .....	92
59.	Physical Medium Dependent (PMD) sublayer and medium, type 1000BASE-LX10 (Long Wavelength) and 1000BASE-BX10 (BiDirectional Long Wavelength) .....	95
59.1	Overview .....	95
59.1.1	Goals and objectives .....	96
59.1.2	Positioning of 1000BASE-LX10 and 1000BASE-BX10 PMDs within the IEEE 802.3 architecture .....	96
59.1.3	Terminology and conventions .....	96
59.1.4	Physical Medium Dependent (PMD) sublayer service interface .....	97
59.1.5	Delay constraints .....	97
59.2	PMD functional specifications .....	98
59.2.1	PMD block diagram .....	98
59.2.2	PMD transmit function .....	98
59.2.3	PMD receive function .....	98
59.2.4	PMD signal detect function .....	99
59.3	PMD to MDI optical specifications for 1000BASE-LX10 .....	99
59.3.1	Transmitter optical specifications .....	99
59.3.2	Receiver optical specifications .....	101
59.4	PMD to MDI optical specifications for 1000BASE-BX10-D and 1000BASE-BX10-U .....	102
59.4.1	Transmit optical specifications .....	102
59.4.2	Receiver optical specifications .....	103
59.5	Illustrative 1000BASE-LX10 and 1000BASE-BX10 channels and penalties (informative) .....	104
59.6	Jitter specifications .....	104
59.7	Optical measurement requirements .....	105
59.7.1	Test patterns .....	105
59.7.2	Wavelength and spectral width measurements .....	108
59.7.3	Optical power measurements .....	109
59.7.4	Extinction ratio measurements .....	109
59.7.5	OMA measurements (informative) .....	109
59.7.6	OMA relationship to extinction ratio and power measurements (informative) .....	109
59.7.7	Relative intensity noise optical modulation amplitude (RIN <sub>12OMA</sub> ) .....	109
59.7.8	Transmitter optical waveform (transmit eye) .....	109
59.7.9	Transmit rise/fall characteristics .....	110
59.7.10	Transmitter and dispersion penalty (TDP) .....	110
59.7.11	Receive sensitivity measurements .....	110
59.7.12	Total jitter measurements (informative) .....	111
59.7.13	Deterministic or high probability jitter measurement (informative) .....	111
59.7.14	Stressed receiver conformance test .....	111
59.7.15	Measurement of the receiver 3 dB electrical upper cutoff frequency .....	112
59.8	Environmental, safety, and labeling specifications .....	112
59.8.1	General safety .....	112

59.8.2	Laser safety .....	113
59.8.3	Installation .....	113
59.8.4	Environment.....	113
59.8.5	PMD labeling requirements .....	113
59.9	Characteristics of the fiber optic cabling .....	113
59.9.1	Fiber optic cabling model .....	114
59.9.2	Optical fiber and cable .....	114
59.9.3	Optical fiber connection.....	115
59.9.4	Medium Dependent Interface (MDI).....	115
59.9.5	Single-mode fiber offset-launch mode-conditioning patch cord for MMF operation of 1000BASE-LX10 .....	116
59.10	Protocol implementation conformance statement (PICS) proforma for Clause 59, Physical Medium Dependent (PMD) sublayer and medium, type 1000BASE-LX10 (Long Wavelength) and 1000BASE-BX10 (BiDirectional Long Wavelength) .....	118
59.10.1	Introduction.....	118
59.10.2	Identification.....	118
59.10.3	Major capabilities/options.....	119
60.	Physical Medium Dependent (PMD) sublayer and medium, type 1000BASE-PX10 and 1000BASE-PX20 (long wavelength passive optical networks).....	123
60.1	Overview.....	123
60.1.1	Goals and objectives .....	124
60.1.2	Positioning of this PMD set within the IEEE 802.3 architecture .....	124
60.1.3	Terminology and conventions .....	124
60.1.4	Physical Medium Dependent (PMD) sublayer service interface.....	125
60.1.5	Delay constraints.....	125
60.2	PMD functional specifications.....	126
60.2.1	PMD block diagram .....	126
60.2.2	PMD transmit function .....	127
60.2.3	PMD receive function.....	127
60.2.4	PMD signal detect function .....	127
60.2.5	PMD transmit enable function for ONU.....	128
60.3	PMD to MDI optical specifications for 1000BASE-PX10-D and 1000BASE-PX10-U.....	128
60.3.1	Transmitter optical specifications .....	128
60.3.2	Receiver optical specifications .....	130
60.4	PMD to MDI optical specifications for 1000BASE-PX20-D and 1000BASE-PX20-U.....	130
60.4.1	Transmit optical specifications .....	131
60.4.2	Receiver optical specifications .....	132
60.5	Illustrative 1000BASE-PX10 and 1000BASE-PX20 channels and penalties .....	133
60.6	Jitter at TP1-4 for 1000BASE-PX10 and 1000BASE-PX20 (informative) .....	134
60.7	Optical measurement requirements .....	136
60.7.1	Frame-based test patterns.....	136
60.7.2	Wavelength and spectral width measurements.....	136
60.7.3	Optical power measurements.....	136
60.7.4	Extinction ratio measurements.....	137
60.7.5	OMA measurements (informative).....	137
60.7.6	OMA relationship to extinction ratio and power measurements (informative)..	137
60.7.7	Relative intensity noise optical modulation amplitude (RIN15OMA).....	137
60.7.8	Transmitter optical waveform (transmit eye) .....	137
60.7.9	Transmitter and dispersion penalty (TDP).....	138
60.7.10	Receive sensitivity measurement.....	138

60.7.11	Stressed receive conformance test .....	138
60.7.12	Jitter measurements (informative) .....	138
60.7.13	Other measurements .....	138
60.8	Environmental, safety, and labeling .....	142
60.8.1	General safety .....	142
60.8.2	Laser safety .....	142
60.8.3	Installation .....	142
60.8.4	Environment.....	142
60.8.5	PMD labeling requirements .....	142
60.9	Characteristics of the fiber optic cabling .....	143
60.9.1	Fiber optic cabling model .....	143
60.9.2	Optical fiber and cable .....	143
60.9.3	Optical fiber connection.....	144
60.9.4	Medium Dependent Interface (MDI).....	144
60.10	Protocol implementation conformance statement (PICS) proforma for Clause 60, Physical Medium Dependent (PMD) sublayer and medium, type 1000BASE-PX10 and 1000BASE-PX20 (long wavelength passive optical networks).....	145
60.10.1	Introduction.....	145
60.10.2	Identification.....	145
60.10.3	Major capabilities/options.....	146
60.10.4	PICS proforma tables for Physical Medium Dependent (PMD) sublayer and medium, type 1000BASE-PX10 and 1000BASE-PX20 (long wavelength passive optical networks).....	146
61.	Physical Coding Sublayer (PCS), Transmission Convergence (TC) sublayer, and common specifications, type 10PASS-TS and type 2BASE-TL .....	151
61.1	Overview .....	151
61.1.1	Scope.....	151
61.1.2	Objectives .....	152
61.1.3	Relation of 2BASE-TL and 10PASS-TS to other standards .....	152
61.1.4	Summary.....	153
61.1.5	Application of 2BASE-TL, 10PASS-TS .....	155
61.2	PCS functional specifications .....	160
61.2.1	MAC-PHY Rate Matching functional specifications .....	160
61.2.2	PME Aggregation functional specifications .....	163
61.2.3	PCS sublayer: Management entity signals.....	172
61.3	TC sublayer functional specifications.....	174
61.3.1	The g-interface .....	175
61.3.2	The a(b)-interface .....	176
61.3.3	TC functions .....	177
61.4	Handshaking and PHY control specification for type 2BASE-TL and 10PASS-TS .....	192
61.4.1	Overview.....	192
61.4.2	Replacement of 1, “Scope”.....	192
61.4.3	Changes to 6.1, “Description of signals”.....	193
61.4.4	Changes to 9.4, “Standard information field (S)”.....	193
61.4.5	Changes to 9.5, “Non-standard information field (NS)” .....	194
61.4.6	Applicability of Annex A–B and Appendix I–VI.....	194
61.4.7	PME Aggregation – remote access of PME Aggregation registers .....	194
61.5	Link segment characteristics.....	197
61.6	MDI specification .....	198
61.7	System considerations.....	198
61.8	Environmental specifications.....	198
61.9	PHY labeling.....	198

61.10	Protocol implementation conformance statement (PICS) proforma for Clause 61, Physical Coding Sublayer (PCS), Transmission Convergence (TC) sublayer, and common specifications type 10PASS-TS, 2BASE-TL.....	199
61.10.1	Introduction.....	199
61.10.2	Identification.....	199
61.10.3	Major capabilities/options.....	200
61.10.4	PICS proforma tables for the Physical Coding Sublayer (PCS), Transmission Convergence (TC) sublayer, and common specifications type 10PASS-TS, 2BASE-TL.....	200
62.	Physical Medium Attachment (PMA) and Physical Medium Dependent (PMD), type 10PASS-TS.....	209
62.1	Overview.....	209
62.1.1	Scope.....	209
62.1.2	Objectives.....	209
62.1.3	Relation of 10PASS-TS to other standards.....	209
62.1.4	Summary of Physical Medium Attachment (PMA) specification.....	209
62.2	PMA functional specifications.....	210
62.2.1	PMA functional diagram.....	210
62.2.2	PMA functional specifications.....	210
62.2.3	General exceptions.....	211
62.2.4	Specific requirements and exceptions.....	212
62.3	PMD functional specifications.....	212
62.3.1	PMD Overview.....	212
62.3.2	PMD functional specifications.....	213
62.3.3	General exceptions.....	213
62.3.4	Specific requirements and exceptions.....	214
62.3.5	Transmission medium interface characteristics.....	222
62.4	Protocol implementation conformance statement (PICS) proforma for Clause 62, Physical Medium Attachment (PMA) and Physical Medium Dependent (PMD), type 10PASS-TS.....	226
62.4.1	Introduction.....	226
62.4.2	Identification.....	226
62.4.3	Major capabilities/options.....	227
62.4.4	PICS proforma tables for the Physical Medium Attachment (PMA) and Physical Medium Dependent (PMD), type 10PASS-TS.....	227
63.	Physical Medium Attachment (PMA) and Physical Medium Dependent (PMD), type 2BASE-TL.....	231
63.1	2BASE-TL Overview.....	231
63.1.1	Scope.....	231
63.1.2	Objectives.....	231
63.1.3	Relation of 2BASE-TL to other standards.....	231
63.1.4	Summary of Physical Medium Attachment (PMA) specification.....	231
63.1.5	Summary of Physical Medium Dependent (PMD) specification.....	233
63.2	2BASE-TL PMA functional specifications.....	234
63.2.1	General exceptions.....	234
63.2.2	Specific requirements and exceptions.....	234
63.3	2BASE-TL PMD functional specifications.....	236
63.3.1	General exceptions.....	236
63.3.2	Specific requirements and exceptions.....	237
63.4	Protocol implementation conformance statement (PICS) proforma for Clause 63, Physical Medium Attachment (PMA) and Physical Medium Dependent (PMD), type 2BASE-TL.....	241

63.4.1	Introduction .....	241
63.4.2	Identification .....	241
63.4.3	Major capabilities/options .....	242
63.4.4	PICS proforma tables for the Physical Medium Attachment (PMA) and Physical Medium Dependent (PMD) sublayers, type 2BASE-TL .....	242
64.	Multipoint MAC Control .....	245
64.1	Overview .....	245
64.1.1	Goals and objectives .....	246
64.1.2	Position of Multipoint MAC Control within the IEEE 802.3 hierarchy .....	246
64.1.3	Functional block diagram .....	248
64.1.4	Service interfaces .....	249
64.1.5	State diagram conventions .....	249
64.2	Multipoint MAC Control operation .....	249
64.2.1	Principles of Multipoint MAC Control .....	250
64.2.2	Multipoint transmission control, Control Parser, and Control Multiplexer .....	252
64.3	Multipoint Control Protocol (MPCP) .....	264
64.3.1	Principles of Multipoint Control Protocol .....	264
64.3.2	Compatibility considerations .....	264
64.3.3	Discovery Processing .....	265
64.3.4	Report Processing .....	278
64.3.5	Gate Processing .....	282
64.3.6	MPCPDU structure and encoding .....	290
64.4	Protocol implementation conformance statement (PICS) proforma for Clause 64, Multipoint MAC Control .....	299
64.4.1	Introduction .....	299
64.4.2	Identification .....	299
64.4.3	Major capabilities/options .....	300
64.4.4	PICS proforma tables for Multipoint MAC Control .....	300
65.	Extensions of the Reconciliation Sublayer (RS) and Physical Coding Sublayer (PCS) / Physical Media Attachment (PMA) for 1000BASE-X for multipoint links and forward error correction .....	303
65.1	Extensions of the Reconciliation Sublayer (RS) for point-to-point emulation .....	303
65.1.1	Overview .....	303
65.1.2	Principle of operation .....	303
65.1.3	Functional specifications .....	304
65.1.3.1	Variables .....	304
65.1.3.2	Transmit .....	304
65.1.3.3	Receive function .....	305
65.2	Extensions of the physical coding sublayer for data detection and forward error correction .....	307
65.2.1	Overview .....	307
65.2.2	Burst-mode operation .....	308
65.2.3	Forward error correction .....	312
65.3	Extensions to PMA for 1000BASE-PX .....	326
65.3.1	Extensions for 1000BASE-PX-U .....	326
65.3.2	Extensions for 1000BASE-PX-D .....	326
65.3.3	Delay variation requirements .....	327
65.4	Protocol implementation conformance statement (PICS) proforma for Clause 65, Extensions of the Reconciliation Sublayer (RS) and Physical Coding Sublayer (PCS) / Physical Media Attachment (PMA) for 1000BASE-X for multipoint links and forward error correction ..	328
65.4.1	Introduction .....	328

65.4.2	Identification .....	328
65.4.3	Major capabilities/options.....	329
65.4.4	PICS proforma tables for Extensions of Reconciliation Sublayer (RS) and Physical Coding Sublayer (PCS) / Physical Media Attachment (PMA) for 1000BASE-X for multipoint links and forward error correction .....	329
66.	Extensions of the 10 Gb/s Reconciliation Sublayer (RS), 100BASE-X PHY, and 1000BASE-X PHY for unidirectional transport .....	333
66.1	Modifications to the physical coding sublayer (PCS) and physical medium attachment (PMA) sublayer, type 100BASE-X.....	333
66.1.1	Overview.....	333
66.1.2	Functional specifications .....	333
66.2	Modifications to the physical coding sublayer (PCS) and physical medium attachment (PMA) sublayer, type 1000BASE-X.....	335
66.2.1	Overview.....	335
66.2.2	Functional specifications .....	335
66.3	Modifications to the reconciliation sublayer (RS) for 10 Gb/s operation.....	336
66.3.1	Overview.....	336
66.3.2	Functional specifications .....	337
66.4	Protocol implementation conformance statement (PICS) proforma for Clause 66, Extensions of the 10 Gb/s Reconciliation Sublayer (RS), 100BASE-X PHY, and 1000BASE-X PHY for unidirectional transport.....	338
66.4.1	Introduction.....	338
66.4.2	Identification.....	338
66.4.3	Major capabilities/options.....	339
66.4.4	PICS proforma tables for Extensions of the 10 Gb/s Reconciliation Sublayer (RS), 100BASE-X PHY, and 1000BASE-X PHY for unidirectional transport.....	339
67.	System considerations for Ethernet subscriber access networks .....	341
67.1	Overview.....	341
67.2	Discussion and examples of EFM P2MP topologies.....	342
67.2.1	Trade off between link span and split ratio.....	342
67.2.2	Single splitter topology .....	342
67.2.3	Tree-and-branch topology.....	342
67.2.4	Interoperability between certain 1000BASE-PX10 and 1000BASE-PX20 .....	343
67.3	Hybrid media topologies.....	343
67.4	Topology limitations.....	343
67.5	Deployment restrictions for subscriber access copper.....	343
67.6	Operations, Administration, and Maintenance .....	344
67.6.1	Unidirectional links.....	344
67.6.2	Active and Passive modes.....	344
67.6.3	Link status signaling in P2MP networks .....	344
68.	Physical medium dependent (PMD) sublayer type 10GBASE-LRM .....	345
68.1	Overview.....	345
68.1.1	Physical Medium Dependent (PMD) sublayer service interface.....	345
68.2	Delay constraints.....	345
68.3	PMD MDIO function mapping .....	346
68.4	PMD functional specifications.....	346
68.4.1	PMD block diagram.....	346
68.4.2	PMD transmit function .....	346

68.4.3	PMD receive function .....	347
68.4.4	PMD signal detect function .....	347
68.4.5	PMD_reset function .....	347
68.4.6	PMD_fault function .....	347
68.4.7	PMD_global_transmit_disable function .....	348
68.4.8	PMD_transmit_fault function .....	348
68.4.9	PMD_receive_fault function .....	348
68.5	PMD to MDI optical specifications .....	348
68.5.1	Transmitter optical specifications .....	349
68.5.2	Characteristics of signal within, and at the receiving end of, a compliant 10GBASE-LRM channel (informative) .....	350
68.5.3	Receiver optical specifications .....	351
68.6	Definitions of optical parameters and measurement methods .....	352
68.6.1	Test patterns and related subclauses for optical parameters .....	352
68.6.2	Optical modulation amplitude (OMA) .....	353
68.6.3	Extinction ratio measurement .....	353
68.6.4	Relationship between OMA, extinction ratio and average power (informative) .....	353
68.6.5	Transmitter optical waveform—transmitter eye mask .....	354
68.6.6	Transmitter waveform and dispersion penalty (TWDP) .....	356
68.6.7	Transmitter signal to noise ratio .....	360
68.6.8	Transmitter uncorrelated jitter .....	360
68.6.9	Comprehensive stressed receiver sensitivity and overload .....	361
68.6.10	Simple stressed receiver sensitivity and overload (informative) .....	364
68.6.11	Receiver jitter tolerance .....	367
68.7	Safety, installation, environment, and labeling .....	368
68.7.1	Safety .....	368
68.7.2	Installation .....	368
68.7.3	Environment .....	368
68.7.4	PMD labeling .....	368
68.8	Fiber optic cabling model .....	368
68.9	Characteristics of the fiber optic cabling (channel) .....	369
68.9.1	Optical fiber and cable .....	369
68.9.2	Optical fiber connections .....	369
68.9.3	Single-mode fiber offset-launch mode-conditioning patch cord .....	370
68.10	Protocol implementation conformance statement (PICS) proforma for Clause 68, Physical medium dependent (PMD) sublayer type 10GBASE-LRM .....	371
68.10.1	Introduction .....	371
68.10.2	Identification .....	371
68.10.3	PICS proforma tables for physical medium dependent (PMD) sublayer type 10GBASE-LRM .....	372
69.	Introduction to Ethernet operation over electrical backplanes .....	377
69.1	Overview .....	377
69.1.1	Scope .....	377
69.1.2	Objectives .....	377
69.1.3	Relationship of Backplane Ethernet to the ISO OSI reference model .....	378
69.2	Summary of Backplane Ethernet Sublayers .....	379
69.2.1	Reconciliation sublayer and media independent interfaces .....	379
69.2.2	Management interface .....	379
69.2.3	Physical Layer signaling systems .....	379
69.2.4	Auto-Negotiation .....	380
69.2.5	Management .....	380

69.3	Delay constraints.....	380
69.4	State diagrams.....	381
69.5	Protocol implementation conformance statement (PICS) proforma.....	381
70.	Physical Medium Dependent Sublayer and Baseband Medium, Type 1000BASE-KX .....	383
70.1	Overview.....	383
70.2	Physical Medium Dependent (PMD) service interface .....	383
70.3	PCS requirements for Auto-Negotiation (AN) service interface.....	383
70.4	Delay constraints.....	383
70.5	PMD MDIO function mapping.....	384
70.6	PMD functional specifications.....	384
70.6.1	Link block diagram .....	384
70.6.2	PMD transmit function .....	385
70.6.3	PMD receive function.....	385
70.6.4	PMD signal detect function .....	385
70.6.5	PMD transmit disable function .....	385
70.6.6	Loopback mode.....	385
70.6.7	PMD fault function .....	386
70.6.8	PMD transmit fault function .....	386
70.6.9	PMD receive fault function.....	386
70.7	1000BASE-KX electrical characteristics.....	386
70.7.1	Transmitter characteristics.....	386
70.7.2	Receiver characteristics .....	390
70.8	Interconnect characteristics.....	391
70.9	Environmental specifications.....	391
70.9.1	General safety .....	391
70.9.2	Network safety.....	391
70.9.3	Installation and maintenance guidelines .....	391
70.9.4	Electromagnetic compatibility.....	391
70.9.5	Temperature and humidity.....	392
70.10	Protocol implementation conformance statement (PICS) proforma for Clause 70, Physical Medium Dependent (PMD) sublayer and baseband medium, type 1000BASE-KX.....	393
70.10.1	Introduction.....	393
70.10.2	Identification.....	393
70.10.3	Major capabilities/options.....	394
70.10.4	PICS proforma tables for Clause 70, Physical Medium Dependent (PMD) sublayer and baseband medium, type 1000BASE-KX. ....	395
71.	Physical Medium Dependent Sublayer and Baseband Medium, Type 10GBASE-KX4 .....	399
71.1	Overview.....	399
71.2	Physical Medium Dependent (PMD) service interface .....	399
71.3	PCS requirements for Auto-Negotiation (AN) service interface.....	399
71.4	Delay constraints.....	399
71.5	PMD MDIO function mapping.....	400
71.6	PMD functional specifications.....	400
71.6.1	Link block diagram .....	401
71.6.2	PMD Transmit function .....	401
71.6.3	PMD Receive function.....	401
71.6.4	Global PMD signal detect function .....	402
71.6.5	PMD lane-by-lane signal detect function .....	402
71.6.6	Global PMD transmit disable function .....	402
71.6.7	PMD lane-by-lane transmit disable function.....	402



71.6.8	Loopback mode.....	402
71.6.9	PMD fault function .....	403
71.6.10	PMD transmit fault function .....	403
71.6.11	PMD receive fault function .....	403
71.7	Electrical characteristics for 10GBASE-KX4 .....	403
71.7.1	Transmitter characteristics .....	403
71.7.2	Receiver characteristics .....	408
71.8	Interconnect characteristics.....	409
71.9	Environmental specifications.....	409
71.9.1	General safety .....	409
71.9.2	Network safety .....	409
71.9.3	Installation and maintenance guidelines .....	409
71.9.4	Electromagnetic compatibility .....	409
71.9.5	Temperature and humidity .....	410
71.10	Protocol implementation conformance statement (PICS) proforma for Clause 71, Physical Medium Dependent (PMD) sublayer and baseband medium, type 10GBASE-KX4 .....	411
71.10.1	Introduction .....	411
71.10.2	Identification .....	411
71.10.3	Major capabilities/options.....	412
71.10.4	PICS proforma tables for Clause 71, Physical Medium Dependent (PMD) sublayer and baseband medium, type 10GBASE-KX4 .....	412
72.	Physical Medium Dependent Sublayer and Baseband Medium, Type 10GBASE-KR.....	417
72.1	Overview.....	417
72.2	Physical Medium Dependent (PMD) service interface .....	417
72.3	PCS requirements for Auto-Negotiation (AN) service interface.....	417
72.4	Delay constraints.....	417
72.5	PMD MDIO function mapping .....	418
72.6	PMD functional specifications.....	418
72.6.1	Link block diagram .....	418
72.6.2	PMD transmit function .....	419
72.6.3	PMD receive function .....	419
72.6.4	PMD signal detect function .....	419
72.6.5	PMD transmit disable function .....	420
72.6.6	Loopback mode.....	420
72.6.7	PMD_fault function .....	420
72.6.8	PMD transmit fault function .....	420
72.6.9	PMD receive fault function.....	420
72.6.10	PMD control function .....	421
72.7	10GBASE-KR electrical characteristics .....	433
72.7.1	Transmitter characteristics .....	433
72.7.2	Receiver characteristics .....	441
72.8	Interconnect characteristics.....	443
72.9	Environmental specifications.....	443
72.9.1	General safety .....	443
72.9.2	Network safety .....	443
72.9.3	Installation and maintenance guidelines .....	443
72.9.4	Electromagnetic compatibility .....	443
72.9.5	Temperature and humidity .....	443
72.10	Protocol implementation conformance statement (PICS) proforma for Clause 72, Physical Medium Dependent (PMD) sublayer and baseband medium, type 10GBASE-KR .....	444
72.10.1	Introduction .....	444
72.10.2	Identification .....	444

72.10.3	Major capabilities/options.....	445
72.10.4	PICS proforma tables for Clause 72, Physical Medium Dependent (PMD) sublayer and baseband medium, type 10GBASE-KR.....	445
73.	Auto-Negotiation for Backplane Ethernet .....	453
73.1	Auto-Negotiation introduction.....	453
73.2	Relationship to the ISO/IEC Open Systems Interconnection (OSI) reference model .....	453
73.3	Functional specifications .....	454
73.4	Transmit function requirements.....	455
73.5	DME transmission .....	455
73.5.1	DME page encoding .....	455
73.5.2	DME page encoding .....	455
73.5.3	DME page timing.....	456
73.6.1	Selector Field .....	458
73.6.2	Echoed Nonce Field.....	458
73.6.3	Transmitted Nonce Field .....	459
73.6.4	Technology Ability Field.....	459
73.6.5	FEC capability .....	459
73.6.6	Pause Ability.....	460
73.6.7	Remote Fault.....	460
73.6.8	Acknowledge .....	460
73.6.9	Next Page.....	460
73.6.10	Transmit Switch function.....	461
73.7	Receive function requirements .....	461
73.7.1	DME page reception .....	461
73.7.2	Receive Switch function .....	461
73.7.3	Link codeword matching .....	461
73.7.4	Arbitration function requirements .....	461
73.7.5	Renegotiation function.....	462
73.7.6	Priority Resolution function.....	462
73.7.7	Next Page function.....	463
73.8	Management register requirements.....	465
73.9	Technology-Dependent interface.....	465
73.9.1	AN_LINK indication .....	465
73.10	State diagrams and variable definitions .....	466
73.10.1	State diagram variables.....	466
73.10.2	State diagram timers .....	472
73.10.3	State diagram counters.....	475
73.10.4	State diagrams.....	476
73.11	Protocol implementation conformance statement (PICS) proforma for Clause 73, Auto-Negotiation for Backplane Ethernet .....	479
73.11.1	Introduction.....	479
73.11.2	Identification .....	479
73.11.3	Major capabilities/options.....	480
73.11.4	PICS proforma tables for Auto-Negotiation for Backplane Ethernet.....	480
74.	Forward Error Correction (FEC) sublayer for 10GBASE-R PHYs .....	487
74.1	Overview.....	487
74.2	Objectives .....	487
74.3	Relationship to other sublayers.....	487
74.4	Inter-sublayer interfaces .....	488
74.4.1	Functional Block Diagram.....	489

74.5	FEC service interface.....	489
74.5.1	FEC_UNITDATA.request.....	490
74.5.2	FEC_UNITDATA.indication.....	490
74.5.3	FEC_SIGNAL.indication.....	491
74.6	Delay constraints.....	491
74.7	FEC principle of operation.....	491
74.7.1	FEC code.....	491
74.7.2	FEC block format.....	492
74.7.3	Composition of the FEC block.....	492
74.7.4	Functions within FEC sublayer.....	493
74.8	FEC MDIO function mapping.....	499
74.8.1	FEC capability.....	499
74.8.2	FEC Enable.....	500
74.8.3	FEC Enable Error Indication.....	500
74.8.4	FEC Error monitoring capability.....	500
74.9	10GBASE-R PHY test-pattern mode.....	501
74.10	Detailed functions and state diagrams.....	501
74.10.1	State diagram conventions.....	501
74.10.2	State variables.....	501
74.10.3	State diagrams.....	502
74.11	Protocol implementation conformance statement (PICS) proforma for Clause 74, Forward Error Correction (FEC) sublayer for 10GBASE-R PHYs.....	504
74.11.1	Introduction.....	504
74.11.2	Identification.....	504
74.11.3	Major capabilities/options.....	505
74.11.4	Management.....	506
74.11.5	FEC Requirements.....	507
74.11.6	FEC Error Monitoring.....	508
Annex 57A (normative) Requirements for support of Slow Protocols.....		509
57A.1	Introduction and rationale.....	509
57A.2	Slow Protocol transmission characteristics.....	509
57A.3	Addressing.....	509
57A.4	Protocol identification.....	510
57A.5	Handling of Slow Protocol frames.....	511
57A.6	Protocol implementation conformance statement (PICS) proforma for Annex 57A, Requirements for support of Slow Protocols.....	512
Annex 57B (normative) Organization specific slow protocol (OSSP).....		514
57B.1	Transmission and representation of octets.....	514
57B.1.1	OSSPDU frame structure.....	514
57B.2	Protocol implementation conformance statement (PICS) proforma for Annex 57B, Organization specific slow protocol (OSSP).....	516
Annex 58A (informative) Frame-based testing.....		519
Annex 61A (informative) EFM Copper examples.....		521
61A.1	Purpose and scope.....	521
61A.2	Aggregation Discovery example.....	521
61A.3	Example of 64/65-octet encapsulation.....	525

Annex 61B (normative) Handshake codepoints for 2BASE-TL and 10PASS-TS.....	529
61B.1 Purpose and scope.....	529
61B.2 Level-1 S field codepoints for 2BASE-TL and 10PASS-TS.....	529
61B.3 Codepoints for 2BASE-TL.....	529
61B.4 Codepoints for 10PASS-TS.....	549
61B.5 Protocol implementation conformance statement (PICS) proforma for Annex 61B, Handshake codepoints for 2BASE-TL and 10PASS-TS.....	555
Annex 62A (normative) PMD profiles for 10PASS-TS.....	557
62A.1 Introduction and rationale.....	557
62A.2 Relationship to other clauses.....	557
62A.3 Profile definitions.....	557
62A.4 Register settings.....	563
62A.5 Protocol implementation conformance statement (PICS) proforma for Annex 62A, PMD profiles for 10PASS-TS.....	565
Annex 62B (normative) Performance guidelines for 10PASS-TS PMD profiles.....	569
62B.1 Introduction and rationale.....	569
62B.2 Relationship to other clauses.....	569
62B.3 Performance test cases.....	569
62B.4 Deployment guidelines.....	571
62B.5 Protocol implementation conformance statement (PICS) proforma for Annex 62B, Performance guidelines for 10PASS-TS PMD profiles.....	572
Annex 62C (informative) 10PASS-TS Examples.....	575
62C.1 Introduction.....	575
62C.2 Bandplan configuration.....	575
62C.3 PSD mask configuration.....	579
Annex 63A (normative) PMD Profiles for 2BASE-TL.....	581
63A.1 Introduction and rationale.....	581
63A.2 Relationship to other clauses.....	581
63A.3 Profile definitions.....	581
63A.4 Register settings.....	582
63A.5 Protocol implementation conformance statement (PICS) proforma Annex 63A, PMD Profiles for 2BASE-TL.....	583
Annex 63B (normative) Performance guidelines for 2BASE-TL PMD profiles.....	585
63B.1 Introduction and rationale.....	585
63B.2 Relationship to other clauses.....	585
63B.3 Performance test cases.....	585
63B.4 Deployment Guidelines.....	587
63B.5 Protocol implementation conformance statement (PICS) proforma for Annex 63B, Performance guidelines for 2BASE-TL PMD profiles.....	588
Annex 67A (informative) Environmental characteristics for Ethernet subscriber access networks.....	591
67A.1 Introduction.....	591

67A.2 Temperature .....	592
67A.3 Temperature impact on optical components .....	594
Annex 69A (normative) Interference tolerance testing .....	597
Annex 69B (informative) Interconnect characteristics .....	601
Annex 73A (normative) Next page message code field definitions .....	611
Annex 74A (informative) FEC block encoding examples.....	613



**IEEE Standard for Information technology—  
Telecommunications and information exchange between systems—  
Local and metropolitan area networks—  
Specific requirements**

## **Part 3: Carrier Sense Multiple Access with Collision Detection (CSMA/CD) Access Method and Physical Layer Specifications**

SECTION ONE: This section includes Clause 1 through Clause 20, Annex A through Annex H, and Annex 4A.

***IMPORTANT NOTICE:** This standard is not intended to assure safety, security, health, or environmental protection in all circumstances. Implementers of the standard are responsible for determining appropriate safety, security, environmental, and health practices or regulatory requirements.*

*This IEEE document is made available for use subject to important notices and legal disclaimers. These notices and disclaimers appear in all publications containing this document and may be found under the heading “Important Notice” or “Important Notices and Disclaimers Concerning IEEE Documents.” They can also be obtained on request from IEEE or viewed at <http://standards.ieee.org/IPR/disclaimers.html>.*

### **1. Introduction**

#### **1.1 Overview**

This is a comprehensive international standard for Local and Metropolitan Area Networks (LANs and MANs), employing CSMA/CD as the shared media access method and the IEEE 802.3 (Ethernet) protocol and frame format for data communication. This international standard is intended to encompass several media types and techniques for a variety of MAC data rates as shown in Figure 1–1 and in 4.4.2.

##### **1.1.1 Scope**

This standard defines Ethernet local area, access and metropolitan area networks. Ethernet is specified at selected speeds of operation; and uses a common media access control (MAC) specification and management information base (MIB). The Carrier Sense Multiple Access with Collision Detection (CSMA/CD) MAC protocol specifies shared medium (half duplex) operation, as well as full duplex operation. Speed specific Media Independent Interfaces (MIIs) provide an architectural and optional implementation interface to selected Physical Layer entities (PHY). The Physical Layer encodes frames for transmission and decodes received frames with the modulation specified for the speed of operation, transmission medium and supported link length. Other specified capabilities include: control and management protocols, and the provision of power over selected twisted pair PHY types.

## 1.1.2 Basic concepts

This standard provides for two distinct modes of operation: half duplex and full duplex. A given IEEE 802.3 instantiation operates in either half or full duplex mode at any one time. The term “CSMA/CD MAC” is used throughout this standard synonymously with “802.3 MAC,” and may represent an instance of either a half duplex or full duplex mode data terminal equipment (DTE), even though full duplex mode DTEs do not implement the CSMA/CD algorithms traditionally used to arbitrate access to shared-media LANs.

### 1.1.2.1 Half duplex operation

In half duplex mode, the CSMA/CD media access method is the means by which two or more stations share a common transmission medium. To transmit, a station waits (defers) for a quiet period on the medium (that is, no other station is transmitting) and then sends the intended message in bit-serial form. If, after initiating a transmission, the message collides with that of another station, then each transmitting station intentionally transmits for an additional predefined period to ensure propagation of the collision throughout the system. The station remains silent for a random amount of time (backoff) before attempting to transmit again. Each aspect of this access method process is specified in detail in subsequent clauses of this standard.

Half duplex operation can be used with certain media types and configurations as defined by this standard. For allowable configurations, see 4.4.2.

### 1.1.2.2 Full duplex operation

Full duplex operation allows simultaneous communication between a pair of stations using point-to-point media (dedicated channel). Full duplex operation does not require that transmitters defer, nor do they monitor or react to receive activity, as there is no contention for a shared medium in this mode. Full duplex mode can only be used when all of the following are true:

- a) The physical medium is capable of supporting simultaneous transmission and reception without interference.
- b) There are exactly two stations connected with a full duplex point-to-point link. Since there is no contention for use of a shared medium, the multiple access (i.e., CSMA/CD) algorithms are unnecessary.
- c) Both stations on the LAN are capable of, and have been configured to use, full duplex operation.

The most common configuration envisioned for full duplex operation consists of a central bridge (also known as a switch) with a dedicated LAN connecting each bridge port to a single device. Repeaters as defined in this standard are outside the scope of full duplex operation.

Full duplex operation constitutes a proper subset of the MAC functionality required for half duplex operation.

## 1.1.3 Architectural perspectives

There are two important ways to view network design corresponding to the following:

- a) *Architecture*. Emphasizing the logical divisions of the system and how they fit together.
- b) *Implementation*. Emphasizing actual components, their packaging, and interconnection.

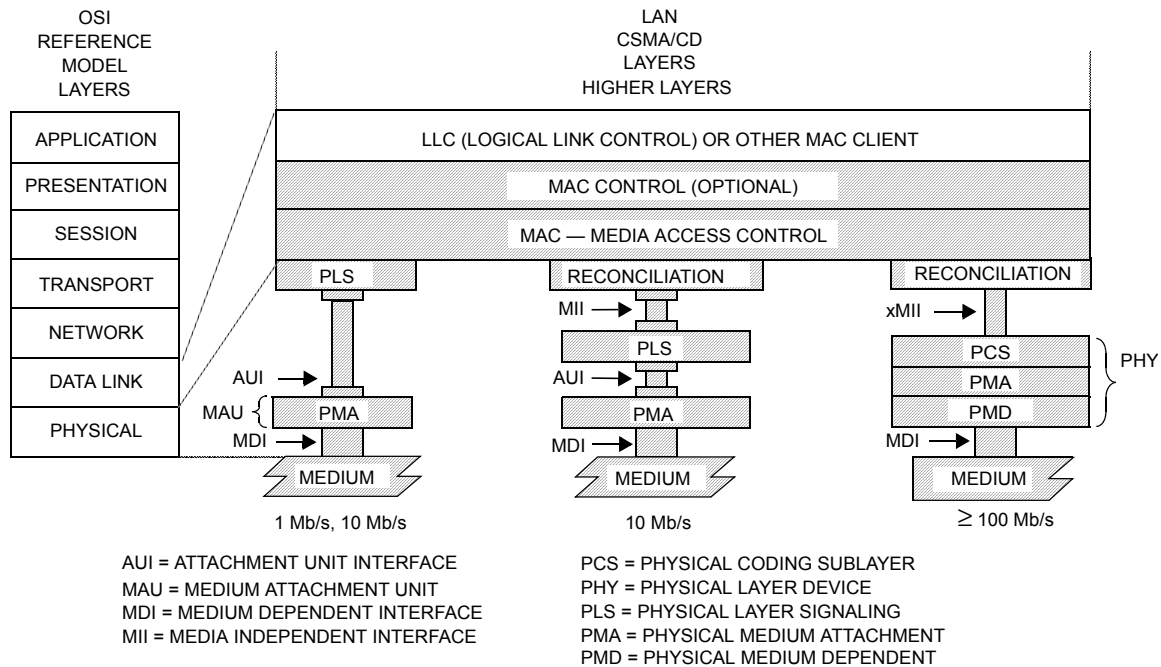
This standard is organized along architectural lines, emphasizing the large-scale separation of the system into two parts: the Media Access Control (MAC) sublayer of the Data Link Layer and the Physical Layer. These layers are intended to correspond closely to the lowest layers of the ISO/IEC Model for Open Systems Interconnection (see Figure 1–1). (See ISO/IEC 7498-1:1994.<sup>1</sup>) The Logical Link Control (LLC) sublayer

---

<sup>1</sup>For information about references, see 1.3.



and MAC sublayer together encompass the functions intended for the Data Link Layer as defined in the OSI model.



NOTE—In this figure, the xMII is used as a generic term for the Media Independent Interfaces for implementations of 100 Mb/s and above. For example: for 100 Mb/s implementations this interface is called MII; for 1 Gb/s implementations it is called GMII; for 10 Gb/s implementations it is called XGMII; etc.

**Figure 1-1—IEEE 802.3 standard relationship to the ISO/IEC Open Systems Interconnection (OSI) reference model**

### 1.1.3.1 Architectural rationale

An architectural organization of the standard has two main advantages:

- Clarity.* A clean overall division of the design along architectural lines makes the standard clearer.
- Flexibility.* Segregation of medium-dependent aspects in the Physical Layer allows the LLC and MAC sublayers to apply to a family of transmission media.

Partitioning the Data Link Layer allows various media access methods within the family of LAN standards.

The architectural model is based on a set of interfaces that may be different from those emphasized in implementations. One critical aspect of the design, however, shall be addressed largely in terms of the implementation interfaces: compatibility.

### 1.1.3.2 Compatibility interfaces

The following important compatibility interfaces are defined within what is architecturally the Physical Layer.

- Medium Dependent Interfaces (MDI).* To communicate in a compatible manner, all stations shall adhere rigidly to the exact specification of physical media signals defined in the appropriate clauses in this standard, and to the procedures that define correct behavior of a station. The medium-independent aspects of the LLC sublayer and the MAC sublayer should not be taken as detracting from this point; communication by way of the ISO/IEC 8802-3 [IEEE Std 802.3] Local Area Network

requires complete compatibility at the Physical Medium interface (that is, the physical cable interface).

- b) *Attachment Unit Interface (AUI)*. Some DTEs are located some distance from their connection to the physical cable. A small amount of circuitry will exist in the Medium Attachment Unit (MAU) directly adjacent to the physical cable, while the majority of the hardware and all of the software will be placed within the DTE. The AUI is defined as a second compatibility interface. While conformance with this interface is not strictly necessary to ensure communication, it is recommended, since it allows maximum flexibility in intermixing MAUs and DTEs. The AUI may be optional or not specified for some implementations of this standard that are expected to be connected directly to the medium and so do not use a separate MAU or its interconnecting AUI cable. The PLS and PMA are then part of a single unit, and no explicit AUI implementation is required.
- c) *Media Independent Interface (MII)*. It is anticipated that some DTEs will be connected to a remote PHY, and/or to different medium dependent PHYs. The MII is defined as a third compatibility interface. While conformance with implementation of this interface is not strictly necessary to ensure communication, it is recommended, since it allows maximum flexibility in intermixing PHYs and DTEs. The MII is optional.
- d) *Gigabit Media Independent Interface (GMII)*. The GMII is designed to connect a 1 Gb/s capable MAC or repeater unit to a 1 Gb/s PHY. While conformance with implementation of this interface is not strictly necessary to ensure communication, it is recommended, since it allows maximum flexibility in intermixing PHYs and DTEs at 1 Gb/s speeds. The GMII is intended for use as a chip-to-chip interface. No mechanical connector is specified for use with the GMII. The GMII is optional.
- e) *Ten-bit Interface (TBI)*. The TBI is provided by the 1000BASE-X PMA sublayer as a physical instantiation of the PMA service interface. The TBI is recommended for 1000BASE-X systems, since it provides a convenient partition between the high-frequency circuitry associated with the PMA sublayer and the logic functions associated with the PCS and MAC sublayers. The TBI is intended for use as a chip-to-chip interface. No mechanical connector is specified for use with the TBI. The TBI is optional.
- f) *10 Gigabit Media Independent Interface (XGMII)*. The XGMII is designed to connect a 10 Gb/s capable MAC to a 10 Gb/s PHY. While conformance with implementation of this interface is not necessary to ensure communication, it allows maximum flexibility in intermixing PHYs and DTEs at 10 Gb/s speeds. The XGMII is intended for use as a chip-to-chip interface. No mechanical connector is specified for use with the XGMII. The XGMII is optional.
- g) *10 Gigabit Attachment Unit Interface (XAUI)*. The XAUI is designed to extend the connection between a 10 Gb/s capable MAC and a 10 Gb/s PHY. While conformance with implementation of this interface is not necessary to ensure communication, it is recommended, since it allows maximum flexibility in intermixing PHYs and DTEs at 10 Gb/s speeds. The XAUI is intended for use as a chip-to-chip interface. No mechanical connector is specified for use with the XAUI. The XAUI is optional.
- h) *10 Gigabit Sixteen-Bit Interface (XSBI)*. The XSBI is provided as a physical instantiation of the PMA service interface for 10GBASE-R and 10GBASE-W PHYs. While conformance with implementation of this interface is not necessary to ensure communication, it provides a convenient partition between the high-frequency circuitry associated with the PMA sublayer and the logic functions associated with the PCS and MAC sublayers. No mechanical connector is specified for use with the XSBI. The XSBI is optional.

### 1.1.4 Layer interfaces

In the architectural model used here, the layers interact by way of well-defined interfaces, providing services as specified in Clause 2 and Clause 6. In general, the interface requirements are as follows:

- a) The interface between the MAC sublayer and its client includes facilities for transmitting and receiving frames, and provides per-operation status information for use by higher-layer error recovery procedures.
- b) The interface between the MAC sublayer and the Physical Layer includes signals for framing (carrier sense, receive data valid, transmit initiation) and contention resolution (collision detect), facilities for passing a pair of serial bit streams (transmit, receive) between the two layers, and a wait function for timing.

These interfaces are described more precisely in 4.3. Additional interfaces are necessary to provide for MAC Control services, and to allow higher level network management facilities to interact with these layers to perform operation, maintenance, and planning functions. Network management functions are described in Clause 30.

### 1.1.5 Application areas

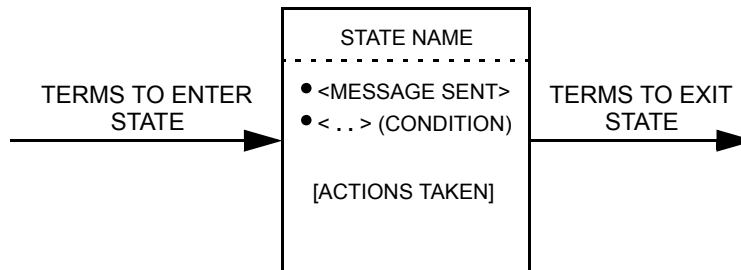
Use of this standard is not restricted to any specific environments or applications.

In the context of this standard, the term “LAN” is used to indicate all networks that utilize the IEEE 802.3 (Ethernet) protocol for communication. These may include (but are not limited to) LANs and MANs.

## 1.2 Notation

### 1.2.1 State diagram conventions

The operation of a protocol can be described by subdividing the protocol into a number of interrelated functions. The operation of the functions can be described by state diagrams. Each diagram represents the domain of a function and consists of a group of connected, mutually exclusive states. Only one state of a function is active at any given time (see Figure 1–2).



Key: ( ) = condition, for example, (if no\_collision)  
 [ ] = action, for example, [reset PLS functions]  
 \* = logical AND  
 + = logical OR, arithmetic addition  
 Tw = Wait Time, implementation dependent  
 Td = Delay Timeout  
 Tb = Backoff Timeout  
 UCT = unconditional transition

**Figure 1–2—State diagram notation example**

Each state that the function can assume is represented by a rectangle. These are divided into two parts by a horizontal line. In the upper part the state is identified by a name in capital letters. The lower part contains the name of any ON signal that is generated by the function. Actions are described by short phrases and enclosed in brackets.

All permissible transitions between the states of a function are represented graphically by arrows between them. A transition that is global in nature (for example, an exit condition from all states to the IDLE or RESET state) is indicated by an open arrow. Labels on transitions are qualifiers that must be fulfilled before the transition will be taken. The label UCT designates an unconditional transition. Qualifiers described by short phrases are enclosed in parentheses.

State transitions and sending and receiving of messages occur instantaneously. When a state is entered and the condition to leave that state is not immediately fulfilled, the state executes continuously, sending the messages and executing the actions contained in the state in a continuous manner.

Some devices described in this standard (e.g., repeaters) are allowed to have two or more ports. State diagrams that are capable of describing the operation of devices with an unspecified number of ports require a qualifier notation that allows testing for conditions at multiple ports. The notation used is a term that includes a description in parentheses of which ports must meet the term for the qualifier to be satisfied (e.g., ANY and ALL). It is also necessary to provide for term-assignment statements that assign a name to a port that satisfies a qualifier. The following conventions are used to describe a term-assignment statement that is associated with a transition:

- a) The character “:” (colon) is a delimiter used to denote that a term assignment statement follows.
- b) The character “←” (left arrow) denotes assignment of the value following the arrow to the term preceding the arrow.

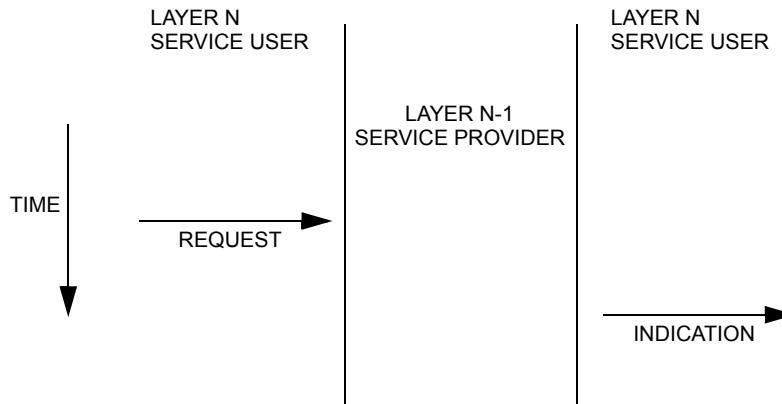
The state diagrams contain the authoritative statement of the functions they depict; when apparent conflicts between descriptive text and state diagrams arise, the state diagrams are to take precedence. This does not override, however, any explicit description in the text that has no parallel in the state diagrams.

The models presented by state diagrams are intended as the primary specifications of the functions to be provided. It is important to distinguish, however, between a model and a real implementation. The models are optimized for simplicity and clarity of presentation, while any realistic implementation may place heavier emphasis on efficiency and suitability to a particular implementation technology. It is the functional behavior of any unit that must match the standard, not its internal structure. The internal details of the model are useful only to the extent that they specify the external behavior clearly and precisely.

### **1.2.2 Service specification method and notation**

The service of a layer or sublayer is the set of capabilities that it offers to a user in the next higher (sub)layer. Abstract services are specified here by describing the service primitives and parameters that characterize each service. This definition of service is independent of any particular implementation (see Figure 1–3).

Specific implementations may also include provisions for interface interactions that have no direct end-to-end effects. Examples of such local interactions include interface flow control, status requests and indications, error notifications, and layer management. Specific implementation details are omitted from this service specification both because they will differ from implementation to implementation and because they do not impact the peer-to-peer protocols.



**Figure 1–3—Service primitive notation**

### 1.2.2.1 Classification of service primitives

Primitives are of two generic types:

- a) **REQUEST.** The request primitive is passed from layer N to layer N-1 to request that a service be initiated.
- b) **INDICATION.** The indication primitive is passed from layer N-1 to layer N to indicate an internal layer N-1 event that is significant to layer N. This event may be logically related to a remote service request, or may be caused by an event internal to layer N-1.

The service primitives are an abstraction of the functional specification and the user-layer interaction. The abstract definition does not contain local detail of the user/provider interaction. For instance, it does not indicate the local mechanism that allows a user to indicate that it is awaiting an incoming call. Each primitive has a set of zero or more parameters, representing data elements that shall be passed to qualify the functions invoked by the primitive. Parameters indicate information available in a user/provider interaction; in any particular interface, some parameters may be explicitly stated (even though not explicitly defined in the primitive) or implicitly associated with the service access point. Similarly, in any particular protocol specification, functions corresponding to a service primitive may be explicitly defined or implicitly available.

### 1.2.3 Physical Layer and media notation

Users of this standard need to reference which particular implementation is being used or identified. Therefore, a means of identifying each implementation is given by a simple, three-field, type notation that is explicitly stated at the beginning of each relevant clause. In general, the Physical Layer type is specified by these fields:

<data rate> <modulation type> <additional distinction>

The data rate, if only a number, is in Mb/s, and if suffixed by a “G”, is in Gb/s. The modulation type (e.g., BASE) indicates how encoded data is transmitted on the medium. The additional distinction may identify characteristics of transmission or medium and, in some cases, the type of PCS encoding used (e.g., “T” for twisted pair, “S” for short wavelength optics, “X” for a block PCS coding used for that speed of operation). Expansions for defined Physical Layer types are included in 1.4.

## 1.2.4 Physical Layer message notation

Messages generated within the Physical Layer, either within or between PLS and the MAU (that is, PMA circuitry), are designated by an italic type to designate either form of physical or logical message used to execute the Physical Layer signaling process (for example, *input\_idle* or *mau\_available*).

## 1.2.5 Hexadecimal notation

Numerical values designated by the 0x prefix indicate a hexadecimal interpretation of the corresponding number. For example: 0x0F represents an 8-bit hexadecimal value of the decimal number 15; 0x00000000 represents a 32-bit hexadecimal value of the decimal number 0; etc.

Numerical values designated with a 16 subscript indicate a hexadecimal interpretation of the corresponding number. For example: 0F<sub>16</sub> represents an 8-bit hexadecimal value of the decimal number 15.

## 1.3 Normative references

The following standards contain provisions that, through reference in this text, constitute provisions of this standard. Standards may be subject to revision, and parties subject to agreements based on this standard are encouraged to investigate the possibility of applying the most recent editions of the standards indicated below. Members of IEC and ISO maintain registers of currently valid international standards. For undated references, the latest edition of the referenced document (including any amendments or corrigenda) applies.

ANSI/EIA-455-95A-2000, Absolute Optical Power Test for Optical Fibers and Cables.<sup>2</sup>

ANSI/EIA/TIA-455-127-1991, FOTP-127—Spectral Characterization of Multimode Laser Diodes.

ANSI T1.105-1995, Telecommunications—Synchronous Optical Network (SONET)—Basic Description including Multiplex Structure, Rates and Formats.

ANSI T1.269-2000, Information Interchange—Structure and Representation of Trace Message Formats For The North American Telecommunications System.

ANSI T1.416-1999, Telecommunications—Network to Customer Installation Interfaces—Synchronous Optical Network (SONET) Physical Layer Specification: Common Criteria.

ANSI T1.417-2001, Spectrum Management For Loop Transmission Systems.

ANSI T1.424-2004, Interface between networks and customer installations—Very-high Speed Digital Subscriber Lines (VDSL) Metallic Interface (Trial-Use Standard).

ANSI T1.601-1992, Telecommunications—Integrated Services Digital Network (ISDN)—Basic Access Interface for Use on Metallic Loops for Application on the Network Side of the NT (Layer 1 Specification).

ANSI T1.605-1991, Telecommunications—Integrated Services Digital Network (ISDN)—Basic Access Interface for S and T Reference Point (Layer 1 Specification).

ANSI X3.230-1994 (FC-PH), Information Technology—Fibre Channel—Physical and Signaling Interface.

---

<sup>2</sup>ANSI publications are available from the Sales Department, American National Standards Institute, 11 West 42nd Street, 13th Floor, New York, NY 10036, USA (<http://www.ansi.org/>).

ANSI X3.263-1995, Revision 2.2 (1 March 1995), FDDI Twisted Pair—Physical Medium Dependent (TP-PMD).

ANSI/TIA-568-B.2-10-2008; Transmission Performance Specifications for 4-pair 100  $\Omega$  Augmented Category 6 Cabling.

ANSI/TIA/EIA-455-175A-92; Chromatic Dispersion Measurement of Single-Mode Optical Fibers by the Differential Phase-Shift Method.

ANSI/TIA/EIA-455-203-2001; Launched Power Distribution Measurement Procedure for Graded-Index Multimode Transmitters.

ANSI/TIA/EIA-455-204-2000; Measurement of Bandwidth on Multimode Fiber.

ANSI/TIA/EIA-568-A, Commercial Building Telecommunications Cabling Standard.

ANSI/TIA/EIA-568-B:2001, Commercial Building Telecommunications Cabling Standard.

ANSI/TIA/EIA-568-B.3-2000; Optical Fiber Cabling Components Standard.

CISPR 22: 1993, Limits and Methods of Measurement of Radio Interference Characteristics of Information Technology Equipment.<sup>3</sup>

EIA/JEDEC Standard EIA/JESD8-6, High Speed Transceiver Logic (HSTL), August 1995.<sup>4</sup>

ETSI TS1 101 270-1 (1999), Transmission and Multiplexing (TM); Access transmission systems on metallic access cables; Very high speed Digital Subscriber Line (VDSL); Part 1: Functional requirements.

ETSI TS 270-2 (2001), Transmission and Multiplexing (TM); Access transmission systems on metallic access cables; Very high speed Digital Subscriber Line (VDSL); Part 2: Transceiver specification.

IEC 60060 (all parts), High-voltage test techniques.<sup>5</sup>

IEC 60068, Basic environmental testing procedures.

IEC 60096-1:1986, Radio-frequency cables, Part 1: General requirements and measuring methods and Amd. 2:1993.

IEC 60169-8:1978 and -16:1982, Radio-frequency connectors, Part 8: R.F. coaxial connectors with inner diameter of outer conductor 6.5 mm (0.256 in) with bayonet lock—Characteristic impedance 50 ohms (Type BNC); Part 16: R.F. coaxial connectors with inner diameter of outer conductor 7 mm (0.276 in) with screw coupling—Characteristic impedance 50 ohms (75 ohms) (Type N).

IEC 60603-7:1990, Connectors for frequencies below 3 MHz for use with printed boards, Part 7: Detail specification for connectors, 8-way, including fixed and free connectors with common mating features, with assessed quality.

---

<sup>3</sup>CISPR documents are available from the International Electrotechnical Commission, 3 rue de Varembe, Case Postale 131, CH 1211, Genève 20, Switzerland/Suisse (<http://www.iec.ch/>). CISPR documents are also available in the United States from the American National Standards Institute.

<sup>4</sup>EIA publications are available from Global Engineering Documents, 15 Inverness Way East, Englewood, Colorado 80112, USA (<http://global.ihs.com/>). JEDEC publications are available from JEDEC, 2001 I Street NW, Washington, DC 20006, USA.

<sup>5</sup>IEC publications are available from IEC Sales Department, Case Postale 131, 3 rue de Varembe, CH-1211, Genève 20, Switzerland/Suisse (<http://www.iec.ch/>). IEC publications are also available in the United States from the American National Standards Institute.

IEC 60793-1:1995, Optical fibres—Part 1: Generic specification.

IEC 60793-1-41:2001, Optical fibres—Part 1-41: Measurement methods and test procedures—Bandwidth.

IEC 60793-2:1992, Optical fibres—Part 2: Product specifications.

IEC 60793-2-10 (2004), Optical fibres—Part 2-10: Product specifications—Sectional specification for category A1 multimode fibres.

IEC 60794-1:1996, Optical fibre cables—Part 1: Generic specification.

IEC 60794-2:1989, Optical fibre cables—Part 2: Product specifications.

IEC 60794-2-11 (2005), Optical fibre cables—Part 2-11: Indoor cables—Detailed specification for simplex and duplex cables for use in premises cabling.

IEC 60794-3-12 (2005), Optical fibre cables—Part 3-12: Outdoor fibre cables—Detailed specification for duct and directly buried optical telecommunication cables for use in premises cabling.

IEC 60807-2:1992, Rectangular connectors for frequencies below 3 MHz, Part 2: Detail specification for a range of connectors with assessed quality, with trapezoidal shaped metal shells and round contacts—Fixed solder contact types.

IEC 60807-3:1990, Rectangular connectors for frequencies below 3 MHz, Part 3: Detail specification for a range of connectors with trapezoidal shaped metal shells and round contacts—Removable crimp contact types with closed crimp barrels, rear insertion/rear extraction.

IEC 60825-1:2001, Edition 1.2, Consolidated Edition; Safety of Laser Products—Part 1: Equipment classification, requirements and user's guide.

IEC 60825-2:1993, Safety of laser products—Part 2: Safety of optical fibre communication systems.

IEC 60874-1:1993, Connectors for optical fibres and cables—Part 1: Generic specification.

IEC 60874-2:1993, Connectors for optical fibres and cables—Part 2: Sectional specification for fibre optic connector, Type F-SMA.

IEC 60874-10:1992, Connectors for optical fibres and cables—Part 10: Sectional specification, Fibre optic connector type BFOC/2,5.

IEC 60950:1991, Safety of information technology equipment.

IEC 60950-1:2001, Information technology equipment—Safety—Part 1: General requirements.

IEC 61000-4-3, Electromagnetic Compatibility (EMC)—Part 4: Testing and measurement techniques—Section 3: Radiated, radio-frequency, electromagnetic field immunity test.

IEC 61076-3-101:1997, Connectors with assessed quality, for use in d.c., low-frequency analogue and in digital high-speed data applications—Part 3: Rectangular connectors—Section 101: Detail specification for a range of shielded connectors with trapezoidal shaped shells and non-removable rectangular contacts on a 1.27 mm × 2.54 mm centre-line.



IEC 61076-3-113, Ed. 1.0 (draft, 48B/1437/CD, 2 April 2004.) [48B Secretariat 1327] Connectors for electronic equipment—Part 3-113: Screened, serial multi-conductor cable to board connectors suitable for 10 Gbit/sec data rates.<sup>6</sup>

IEC 61076-3-103 (48B/574/NP), Detail specification for rectangular connectors, with assessed quality, 6 and 8 way, fixed and free shielded connectors with ribbon contacts for high speed data applications.

IEC 61196-1:1995, Radio-frequency cables—Part 1: Generic specification—General, definitions, requirements and test methods.

IEC 61280-1-4 (2003), Fibre optic communication subsystem test procedures—Part 1-4: General communication subsystems—Collection and reduction of two-dimensional nearfield data for multimode fibre laser transmitters.

IEC 61280-2-2 (2008), Fiber optic communication sub-system basic test procedures—Part 2-2: Test procedures for digital systems – Optical eye pattern, waveform, and extinction ratio.

IEC 61280-4-1 (2003), Fiber-optic communication subsystem test procedures—Part 4-1: Cable plant and links—Multimode fibre-optic cable plant attenuation measurement.

IEC 61754-1:1996, Fibre optic interfaces —Part 1: General and guidance.

IEC 61753-1-1:2000, Fibre optic interconnecting devices and passive components performance standard - Part 1-1: General and guidance—Interconnecting devices (connectors).

IEC 61753-021-2 (2002-07), Fibre optic passive component performance standard—Part 021-2: Fibre optic connectors terminated on single-mode fibre to category C Controlled environment.

IEC 61753-022-2, Performance standard—Part 022-2: Fibre optic connectors terminated on multimode fibre for Category C—Controlled environment, performance Class M.

IEC 61754-4:1997, Fibre optic connector interfaces—Part 4: Type SC connector family.

IEEE Std 802<sup>®</sup>-2001, IEEE Standards for Local and Metropolitan Area Networks: Overview and Architecture.<sup>7</sup>

IEEE Std 802.1D<sup>™</sup>, IEEE Standard for Local and metropolitan area networks Media Access Control (MAC) Bridges.

IEEE Std 802.1F<sup>™</sup>-1993 (Reaff 1998), IEEE Standards for Local and Metropolitan Area Networks: Common Definitions and Procedures for IEEE 802 Management Information.<sup>8</sup>

IEEE Std 802.1Q<sup>™</sup>, IEEE Standard for Local and Metropolitan Area Networks: Virtual Bridged Local Area Networks.

IEEE Std 802a<sup>™</sup>-2003, IEEE Standard for Local and Metropolitan Area Networks: Overview and Architecture —Amendment 1: Ethertypes for prototype and vendor-specific protocol development.

<sup>6</sup>Presently, IEC 61076-3-113 is a committee draft.

<sup>7</sup>IEEE publications are available from the Institute of Electrical and Electronics Engineers, 445 Hoes Lane, Piscataway, NJ 08854, USA (<http://standards.ieee.org/>).

<sup>8</sup>The IEEE standards or products referred to in this clause are trademarks of the Institute of Electrical and Electronics Engineers, Inc.

IETF RFC 1155 (May 1990), *Structure and Identification of Management Information for TCP/IP-based Internets*, Rose, M., and McCloghrie, K.<sup>9</sup>

IETF RFC 1157 (May 1990), *A Simple Network Management Protocol (SNMP)*, Case, J., Fedor, M., Schoffstall, M., and Davin, J.

IETF RFC 1212 (March 1991), *Concise MIB Definitions*, Rose, M., and McCloghrie, K.

IETF RFC 1213 (IETF STD 17) (March 1991), *Management Information Base for Network Management of TCP/IP-based internets: MIB-II*, McCloghrie K., and Rose, M.

IETF RFC 1215 (March 1991), *A Convention for Defining Traps for use with the SNMP*, Rose, M.

IETF RFC 1901 (January 1996), *Introduction to Community-based SNMPv2*, Case, J., McCloghrie, K., Rose, M., and Waldbusser, S.

IETF RFC 2578 (January 1996), *Structure of Management Information for Version 2 of the Simple Network Management Protocol (SNMPv2)*, Case, J., McCloghrie, K., Rose, M., and Waldbusser, S.

IETF RFC 2579 (January 1996), *Textual Conventions for Version 2 of the Simple Network Management Protocol (SNMPv2)*, Case, J., McCloghrie, K., Rose, M., and Waldbusser, S.

IETF RFC 2580 (January 1996), *Conformance Statements for Version 2 of the Simple Network Management Protocol (SNMPv2)*, Case, J., McCloghrie, K., Rose, M., and Waldbusser, S.

IETF RFC 3416 (January 1996), *Protocol Operations for Version 2 of the Simple Network Management Protocol (SNMPv2)*, Case, J., McCloghrie, K., Rose, M., and Waldbusser, S.

IETF RFC 3417 (January 1996), *Transport Mappings for Version 2 of the Simple Network Management Protocol (SNMPv2)*, Case, J., McCloghrie, K., Rose, M., and Waldbusser, S.

IETF RFC 2863 (November 1997), *The Interfaces Group MIB using SMIV2*, McCloghrie, K., and Kastenholz, F.

IETF RFC 2571 (January 1998), *An Architecture for Describing SNMP Management Frameworks*, Harrington, D., Presuhn, R., and Wijnen, B.

IETF RFC 2572 (January 1998), *Message Processing and Dispatching for the Simple Network Management Protocol (SNMP)*, Case, J., Harrington D., Presuhn R., and Wijnen, B.

IETF RFC 2573 (January 1998), *SNMPv3 Applications*, Levi, D., Meyer, P., and Stewart, B.

IETF RFC 2574 (January 1998), *User-based Security Model (USM) for version 3 of the Simple Network Management Protocol (SNMPv3)*, Blumenthal, U., and Wijnen, B.

IETF RFC 2575 (January 1998), *View-based Access Control Model (VACM) for the Simple Network Management Protocol (SNMP)*, Wijnen, B., Presuhn, R., and McCloghrie, K.

INCITS-TR-25:1999—Fibre Channel Methodologies for Jitter Specification.<sup>10</sup>

ISO/IEC 2382-9:1995, Information technology—Vocabulary—Part 9: Data communication.<sup>11</sup>

<sup>9</sup>IETF RFCs are available from the Internet Engineering Task Force website at <http://www.ietf.org/rfc.html>.

<sup>10</sup>INCITS publications are available at <http://www.incits.org>.

ISO/IEC 7498-1:1994, Information technology—Open Systems Interconnection—Basic Reference Model: The Basic Model.

ISO/IEC 7498-4:1989, Information processing systems—Open Systems Interconnection—Basic Reference Model—Part 4: Management Framework.

ISO/IEC 8824:1990, Information technology—Open Systems Interconnection—Specification of Abstract Syntax Notation One (ASN.1).

ISO/IEC 8825:1990, Information technology—Open Systems Interconnection—Specification of basic encoding rules for Abstract Syntax Notation One (ASN.1).

ISO/IEC 9314-1:1989, Information processing systems—Fibre Distributed Data Interface (FDDI)—Part 1: Token Ring Physical Layer Protocol (PHY).

ISO/IEC 9314-2:1989, Information processing systems—Fibre Distributed Data Interface (FDDI)—Part 2: Token Ring Media Access Control (MAC).

ISO/IEC 9314-3:1990, Information processing systems—Fibre Distributed Data Interface (FDDI)—Part 3: Physical Layer Medium Dependent (PMD).

ISO/IEC 9646-1:1994, Information technology—Open Systems Interconnection—Conformance testing methodology and framework—Part 1: General concepts.

ISO/IEC 9646-2:1994, Information technology—Open Systems Interconnection—Conformance testing methodology and framework—Part 2: Abstract test suite specification.

ISO/IEC 10040:1992, Information technology—Open Systems Interconnection—Systems management overview.

ISO/IEC 10164-1:1993, Information technology—Open Systems Interconnection—Systems management—Part 1: Object Management Function.

ISO/IEC 10165-1:1993, Information technology—Open Systems Interconnection—Management information services—Structure of management information—Part 1: Management Information Model.

ISO/IEC 10165-2:1992, Information technology—Open Systems Interconnection—Structure of management information: Definition of management information.

ISO/IEC 10165-4:1992, Information technology—Open Systems Interconnection—Management information services—Structure of management information—Part 4: Guidelines for the definition of managed objects.

ISO/IEC 10742:1994, Information technology—Telecommunications and information exchange between systems—Elements of management information related to OSI Data Link Layer standards.

ISO/IEC 11801:1995, Information technology—Generic cabling for customer premises.<sup>12</sup>

---

<sup>11</sup>ISO/IEC publications are available from the ISO Central Secretariat, Case Postale 56, 1 rue de Varembe, CH-1211, Genève 20, Switzerland/Suisse (<http://www.iso.ch/>). ISO publications are also available in the United States from the Sales Department, American National Standards Institute, 11 West 42nd Street, 13th Floor, New York, NY 10036, USA (<http://www.ansi.org/>).

<sup>12</sup>Previous editions of ISO/IEC standards are available from Deutsches Institut für Normung, Burggrafenstrasse 6, 10787 Berlin, Germany (<http://www.din.de>).

ISO/IEC 11801:2002, Information technology—Generic cabling for customer premises.

ISO/IEC 11801:2002/Amendment 1:2008, Information technology—Generic cabling for customer premises.

ISO/IEC 15802-1:1995, Information technology—Telecommunications and information exchange between systems—Local and metropolitan area networks—Common specifications—Part 1: Medium Access Control (MAC) service definition.

ISO/IEC 15802-2:1995 [ANSI/IEEE Std 802.1B™-1992 and IEEE Std 802.1k™-1993], Information technology—Telecommunications and information exchange between systems—Local and metropolitan area networks—Common specifications—Part 2: LAN/MAN Management.

ISO/IEC TR 24750:2007 Information technology—Assessment and mitigation of installed balanced cabling channels in order to support of 10GBASE-T.

ITU-T Recommendation G.652, 2000—Characteristics of a single-mode optical fibre cable.<sup>13</sup>

ITU-T Recommendation G.691, 2006—Optical interfaces for single-channel STM-64 and other SDH systems with optical amplifiers.

ITU-T Recommendation G.957, 2006—Optical interfaces for equipments and systems relating to the synchronous digital hierarchy (SDH).

ITU-T Recommendation G.975—Forward error correction for submarine systems.

ITU-T Recommendation G.991.2, 2001—Amendment 1.

ITU-T Recommendation G.991.2, 2001—Single-pair high-speed digital subscriber line (SHDSL) transceivers.

ITU-T Recommendation G.993.1, 2003—Amendment 1.

ITU-T Recommendation G.993.1, 2001—Very high-speed digital subscriber line foundation.

ITU-T Recommendation G.994.1, 2004—Handshake procedures for digital subscriber line (DSL) transceivers.

ITU-T Recommendation I.430, 1995—Basic user-network interface—Layer 1 specification.

ITU-T Recommendation O.150, 1996—General requirements for instrumentation for performance measurements on digital transmission equipment.

ITU-T Recommendation O.153, 1992—Basic parameters for the measurement of error performance at bit rates below the primary rate.

ITU-T Recommendation O.172, 1999—Jitter and wander measuring equipment for digital systems which are based on the synchronous digital hierarchy (SDH).

MATLAB Matrix Laboratory Software.<sup>14</sup>

<sup>13</sup>ITU-T publications are available from the International Telecommunications Union, Place des Nations, CH-1211, Geneva 20, Switzerland (<http://www.itu.int/>).

<sup>14</sup>For information on MatLab contact: The MathWorks, 24 Park Way, Natick, MA, (<http://www.mathworks.com>).

TIA-492AAAC-2002; Detail Specification for 850-nm Laser-Optimized, 50-um core diameter/125-um cladding diameter class Ia graded-index multimode optical fibers.<sup>15</sup>

TIA TSB-155; Guidelines for the Assessment and Mitigation of Installed Category 6 Cabling to Support 10GBASE-T, March 2007

NOTE —Local and national standards such as those supported by ANSI, EIA, MIL, NFPA, and UL are not a formal part of this standard except where no international standard equivalent exists. A number of local and national standards are referenced as resource material; these bibliographical references are located in the bibliography in Annex A.<sup>16</sup>

## 1.4 Definitions

**1.4.1 10BASE2:** IEEE 802.3 Physical Layer specification for a 10 Mb/s CSMA/CD local area network over RG 58 coaxial cable. (See IEEE 802.3, Clause 10.)

**1.4.2 10BASE5:** IEEE 802.3 Physical Layer specification for a 10 Mb/s CSMA/CD local area network over coaxial cable (i.e., thicknet). (See IEEE 802.3, Clause 8.)

**1.4.3 10BASE-F:** IEEE 802.3 Physical Layer specification for a 10 Mb/s CSMA/CD local area network over fiber optic cable. (See IEEE 802.3, Clause 15.)

**1.4.4 10BASE-FB port:** A port on a repeater that contains an internal 10BASE-FB Medium Attachment Unit (MAU) that can connect to a similar port on another repeater. (See IEEE 802.3, Clause 9, Figure 15–1b, and Clause 17.)

**1.4.5 10BASE-FB segment:** A fiber optic link segment providing a point-to-point connection between two 10BASE-FB ports on repeaters. (See link segment IEEE 802.3, Figure 15–1b and Figure 15–2.)

**1.4.6 10BASE-FL segment:** A fiber optic link segment providing point-to-point connection between two 10BASE-FL Medium Attachment Units (MAUs). (See link segment IEEE 802.3, Figure 15–1c and Figure 15–2.)

**1.4.7 10BASE-FP segment:** A fiber optic mixing segment, including one 10BASE-FP Star and all of the attached fiber pairs. (See IEEE 802.3, Figure 15–1a, Figure 1–3, and mixing segment.)

**1.4.8 10BASE-FP Star:** A passive device that is used to couple fiber pairs together to form a 10BASE-FP segment. Optical signals received at any input port of the 10BASE-FP Star are distributed to all of its output ports (including the output port of the optical interface from which it was received). A 10BASE-FP Star is typically comprised of a passive-star coupler, fiber optic connectors, and a suitable mechanical housing. (See IEEE 802.3, 16.5.)

**1.4.9 10BASE-T:** IEEE 802.3 Physical Layer specification for a 10 Mb/s CSMA/CD local area network over two pairs of twisted-pair telephone wire. (See IEEE 802.3, Clause 14.)

**1.4.10 100BASE-BX10:** IEEE 802.3 Physical Layer specification for a 100 Mb/s point-to-point link over one single-mode fiber. The link includes two different specifications for 100BASE-BX10-D and 100BASE-BX10-U. (See IEEE 802.3, Clause 58 and Clause 66.)

**1.4.11 100BASE-FX:** IEEE 802.3 Physical Layer specification for a 100 Mb/s CSMA/CD local area network over two multimode optical fibers. (See IEEE 802.3, Clause 24 and Clause 26.)

<sup>15</sup>TIA publications are available from Global Engineering Documents, 15 Inverness Way East, Englewood, Colorado 80112, USA or online at <http://www.tiaonline.org>.

<sup>16</sup>Notes in text, tables, and figures are given for information only and do not contain requirements needed to implement the standard.

**1.4.12 100BASE-LX10:** IEEE 802.3 Physical Layer specification for a 100 Mb/s point-to-point link over two single-mode optical fibers. (See IEEE 802.3, Clause 58 and Clause 66.)

**1.4.13 100BASE-T:** IEEE 802.3 Physical Layer specification for a 100 Mb/s CSMA/CD local area network. (See IEEE 802.3, Clause 22 and Clause 28.)

**1.4.14 100BASE-T2:** IEEE 802.3 specification for a 100 Mb/s CSMA/CD local area network over two pairs of Category 3 or better balanced cabling. (See IEEE 802.3, Clause 32.)

**1.4.15 100BASE-T4:** IEEE 802.3 Physical Layer specification for a 100 Mb/s CSMA/CD local area network over four pairs of Category 3, 4, and 5 unshielded twisted-pair (UTP) wire. (See IEEE 802.3 Clause 23.)

**1.4.16 100BASE-TX:** IEEE 802.3 Physical Layer specification for a 100 Mb/s CSMA/CD local area network over two pairs of Category 5 unshielded twisted-pair (UTP) or shielded twisted-pair (STP) wire. (See IEEE 802.3, Clause 24 and Clause 25.)

**1.4.17 100BASE-X:** IEEE 802.3 Physical Layer specification for a 100 Mb/s CSMA/CD local area network that uses the Physical Medium Dependent (PMD) sublayer and Medium Dependent Interface (MDI) of the ISO/IEC 9314 group of standards developed by ASC X3T12 (FDDI). (See IEEE 802.3, Clause 24.)

**1.4.18 1000BASE-BX10:** IEEE 802.3 Physical Layer specification for a 1000 Mb/s point-to-point link over one single-mode optical fiber. (See IEEE 802.3, Clause 59 and Clause 66.)

**1.4.19 1000BASE-CX:** 1000BASE-X over specialty shielded balanced copper jumper cable assemblies. (See IEEE 802.3, Clause 39.)

**1.4.20 1000BASE-KX:** IEEE 802.3 Physical Layer specification for 1 Gb/s using 1000BASE-X encoding over an electrical backplane. (See IEEE 802.3 Clause 70.)

**1.4.21 1000BASE-LX:** 1000BASE-X using long wavelength laser devices over multimode and single-mode fiber. (See IEEE 802.3, Clause 38.)

**1.4.22 1000BASE-LX10:** IEEE 802.3 Physical Layer specification for a 1000 Mb/s point-to-point link over two single-mode or multimode optical fibers. (See IEEE 802.3, Clause 59 and Clause 66.)

**1.4.23 1000BASE-PX10:** IEEE 802.3 Physical Layer specification for a 1000 Mb/s point to multipoint link over one single-mode optical fiber, with a reach of up to 10 km. (See IEEE 802.3, Clause 60, Clause 65, and Clause 66.)

**1.4.24 1000BASE-PX20:** IEEE 802.3 Physical Layer specification for a 1000 Mb/s point to multipoint link over one single-mode optical fiber, with a reach of up to 20 km. (See IEEE 802.3, Clause 60, Clause 65, and Clause 66.)

**1.4.25 1000BASE-SX:** 1000BASE-X using short wavelength laser devices over multimode fiber. (See IEEE 802.3, Clause 38.)

**1.4.26 1000BASE-T:** IEEE 802.3 Physical Layer specification for a 1000 Mb/s CSMA/CD LAN using four pairs of Category 5 balanced copper cabling. (See IEEE 802.3, Clause 40.)

**1.4.27 1000BASE-X:** IEEE 802.3 Physical Layer specification for a 1000 Mb/s CSMA/CD LAN that uses a Physical Layer derived from ANSI X3.230-1994 (FC-PH) [B22]<sup>17</sup>. (See IEEE 802.3, Clause 36.)

---

<sup>17</sup>The numbers in brackets preceded by the letter B correspond to those of the bibliography in Annex A.

**1.4.28 10BROAD36:** IEEE 802.3 Physical Layer specification for a 10 Mb/s CSMA/CD local area network over single broadband cable. (See IEEE 802.3, Clause 11.)

**1.4.29 10GBASE-CX4:** IEEE 802.3 Physical Layer specification for 10 Gb/s using 10GBASE-X encoding over four lanes over shielded balanced copper cabling. (See IEEE 802.3, Clause 54.)

**1.4.30 10GBASE-E:** IEEE 802.3 PMD specifications for 10 Gb/s serial transmission using extra long wavelength. (See IEEE 802.3, Clause 52.)

**1.4.31 10GBASE-ER:** IEEE 802.3 Physical Layer specification for 10 Gb/s using 10GBASE-R encoding and 10GBASE-E optics. (See IEEE 802.3, Clause 49 and Clause 52.)

**1.4.32 10GBASE-EW:** IEEE 802.3 Physical Layer specification for 10Gb/s using 10GBASE-W encoding and 10GBASE-E optics. (See IEEE 802.3, Clause 50 and Clause 52.)

**1.4.33 10GBASE-KR:** IEEE 802.3 Physical Layer specification for 10 Gb/s using 10GBASE-R encoding over an electrical backplane. (See IEEE 802.3 Clause 72.)

**1.4.34 10GBASE-KX4:** IEEE 802.3 Physical Layer specification for 10 Gb/s using 10GBASE-X encoding over an electrical backplane. (See IEEE 802.3 Clause 71.)

**1.4.35 10GBASE-L:** IEEE 802.3 PMD specifications for 10 Gb/s serial transmission using long wavelength. (See IEEE 802.3, Clause 52)

**1.4.36 10GBASE-LR:** IEEE 802.3 Physical Layer specification for 10 Gb/s using 10GBASE-R encoding and 10GBASE-L optics. (See IEEE 802.3, Clause 49 and Clause 52.)

**1.4.37 10GBASE-LRM:** IEEE 802.3 Physical Layer specification for 10 Gb/s using 10GBASE-R encoding and long wavelength optics for multimode fiber (see IEEE 802.3 Clause 68).

**1.4.38 10GBASE-LW:** IEEE 802.3 Physical Layer specification for 10 Gb/s using 10GBASE-W encoding and 10GBASE-L optics. (See IEEE 802.3, Clause 50 and Clause 52.)

**1.4.39 10GBASE-LX4:** IEEE 802.3 Physical Layer specification for 10 Gb/s using 10GBASE-X encoding over four WWDM lanes over multimode fiber. (See IEEE 802.3, Clause 54.)

**1.4.40 10GBASE-R:** An IEEE 802.3 physical coding sublayer for serial 10 Gb/s operation. (See IEEE 802.3, Clause 49.)

**1.4.41 10GBASE-S:** IEEE 802.3 PMD specifications for 10 Gb/s serial transmission using short wavelength. (See IEEE 802.3, Clause 52.)

**1.4.42 10GBASE-SR:** IEEE 802.3 Physical Layer specification for 10 Gb/s using 10GBASE-R encoding and 10GBASE-S optics. (See IEEE 802.3, Clause 49 and Clause 52.)

**1.4.43 10GBASE-SW:** IEEE 802.3 Physical Layer specification for 10 Gb/s using 10GBASE-W encoding and 10GBASE-S optics. (See IEEE 802.3, Clause 50 and Clause 52.)

**1.4.44 10GBASE-T:** IEEE 802.3 Physical Layer specification for a 10 Gb/s LAN using four pairs of Class E or Class F balanced copper cabling. (See IEEE Std 802.3, Clause 55.)

**1.4.45 10GBASE-W:** An IEEE 802.3 physical coding sublayer for serial 10 Gb/s operation that is data-rate and format compatible with SONET STS-192c. (See IEEE 802.3, Clause 49.)

**1.4.46 10GBASE-X:** An IEEE 802.3 physical coding sublayer for 10 Gb/s operation over XAUI and four lane PMDs. (See IEEE 802.3, Clause 48.)

**1.4.47 10PASS-TS:** IEEE 802.3 Physical Layer specification up to 100 Mb/s point-to-point link over single copper wire pair. (See IEEE 802.3, Clause 61 and Clause 62.)

**1.4.48 1BASE5:** IEEE 802.3 Physical Layer specification for a 1 Mb/s CSMA/CD local area network over two pairs of twisted-pair telephone wire. (See IEEE 802.3, Clause 12.)

**1.4.49 2BASE-TL:** IEEE 802.3 Physical Layer specification up to 5.696 Mb/s point-to-point link over single copper wire pair. (See IEEE 802.3, Clause 61 and Clause 63.)

**1.4.50 10 Gigabit Attachment Unit Interface (XAUI):** The interface between two 10 Gigabit Extender Sublayers (XGXS) to extend the reach of the XGMII for 10 Gb/s operation. (See IEEE 802.3, Clause 47.)

**1.4.51 10 Gigabit Media Independent Interface (XGMII):** The interface between the Reconciliation Sublayer (RS) and the Physical Coding Sublayer (PCS) for 10 Gb/s operation. (See IEEE 802.3, Clause 46.)

**1.4.52 10 Gigabit Sixteen-Bit Interface (XSBI):** The interface between the Physical Coding Sublayer (PCS) in 10GBASE-R or the WAN Interface Sublayer (WIS) in 10GBASE-W and the Physical Medium Attachment (PMA) sublayer for 10 Gb/s operation. (See IEEE 802.3, Clause 51.)

**1.4.53 4D-PAM5:** The symbol encoding method used in 1000BASE-T. The four-dimensional quinary symbols (4D) received from the 8B1Q4 data encoding are transmitted using five voltage levels (PAM5). Four symbols are transmitted in parallel each symbol period. (See IEEE 802.3, Clause 40.)

**1.4.54 8B/10B transmission code:** A dc-balanced octet-oriented data encoding specified in Table 36–1a–e and Table 36–2.

**1.4.55 8B1Q4:** For IEEE 802.3, the data encoding technique used by 1000BASE-T when converting GMII data (8B-8 bits) to four quinary symbols (Q4) that are transmitted during one clock (1Q4). (See IEEE 802.3, Clause 40.)

**1.4.56 64B/65B transmission code:** A block oriented encoding where 64-bit blocks are prepended with a single bit to indicate whether the block contains only data or a mix of data and control information. (See IEEE Std 802.3, Clause 55.)

**1.4.57 ability:** A mode that a device can advertise using Auto-Negotiation. For modes that represent a type of data service, a device shall be able to operate that data service before it may advertise this ability. A device may support multiple abilities. (See IEEE 802.3, 28.2.1.2.2.)

**1.4.58 Acknowledge Bit:** A bit used by IEEE 802.3 Auto-Negotiation to indicate that a station has successfully received multiple identical copies of the link codeword. This bit is only set after an identical link codeword has been received three times in succession. (See IEEE 802.3, 28.2.1.2.5.)

**1.4.59 advertised ability:** An operational mode that is advertised using Auto-Negotiation. (See IEEE 802.3, 28.2.1.2.2.)

**1.4.60 agent:** A term used to refer to the managed nodes in a network. Managed nodes are those nodes that contain a network management entity (NME), which can be used to configure the node and/or collect data describing operation of that node. The agent is controlled by a network control host or manager that contains both an NME and network management application (NMA) software to control the operations of agents. Agents include systems that support user applications as well as nodes that provide communications services such as front-end processors, bridges, and routers. (See IEEE 802.3, Clause 30.)



**1.4.61 agent code:** A term used to refer to network management entity software residing in a node that can be used to remotely configure the host system based on commands received from the network control host, collect information documenting the operation of the host, and communicate with the network control host. (See IEEE 802.3, Clause 30.)

**1.4.62 Aggregation group:** A collection of PMEs that may be aggregated according to a particular implementation of the PME aggregation function. (See IEEE 802.3, 61.2.2.)

**1.4.63 agile device:** A device that supports automatic switching between multiple Physical Layer technologies. (See IEEE 802.3, Clause 28.)

**1.4.64 anomaly:** A discrepancy between the actual and desired characteristics of an item. This definition is derived from ANSI T1.416-1999 and ANSI T1.105-1995, which take precedence.

**1.4.65 arbitration:** In 1000BASE-X, Auto-Negotiation process that ensures proper sequencing of configuration information between link partners using the Physical Coding Sublayer (PCS) Transmit and Receive functions. (See IEEE 802.3, Clause 36 and Clause 37.)

**1.4.66 Attachment Unit Interface (AUI):** In 10 Mb/s CSMA/CD, the interface between the Medium Attachment Unit (MAU) and the data terminal equipment (DTE) within a data station. Note that the AUI carries encoded signals and provides for duplex data transmission. (See IEEE 802.3, Clause 7 and Clause 8.)

**1.4.67 Auto-Negotiation:** The algorithm that allows two devices at either end of a link segment to negotiate common data service functions. (See IEEE 802.3, Clause 28.)

**1.4.68 balanced cable:** A cable consisting of one or more metallic symmetrical cable elements (twisted pairs or quads). (From ISO/IEC 11801.)

**1.4.69 Bandplan:** The set of parameters that control the lowest and highest frequencies and power at which 10PASS-TS and 2BASE-TL may operate.

**1.4.70 baseband coaxial system:** A system whereby information is directly encoded and impressed upon the transmission medium. At any point on the medium only one information signal at a time can be present without disruption.

**1.4.71 Base link codeword:** The first 16-bit message exchanged during IEEE 802.3 Auto-Negotiation. (See IEEE 802.3, 28.2.1.2.)

**1.4.72 Base page:** *See:* **Base link codeword.**

**1.4.73 basic frame:** A MAC frame that carries a Length/Type field with the Length or Type interpretation and has a maximum length of 1518 octets. The basic frame is not intended to allow inclusion of additional tags (i.e., untagged) or encapsulations required by higher layer protocols. (See IEEE 802.3, 3.2.7.)

**1.4.74 baud (Bd):** A unit of signaling speed, expressed as the number of times per second the signal can change the electrical state of the transmission line or other medium.

NOTE—Depending on the encoding strategies, a signal event may represent a single bit, more, or less than one bit. *Contrast with:* **bit rate; bits per second.** (From IEEE Std 610.7-1995 [B44].)

**1.4.75 Binary Phase Shift Keying (Binary PSK or BPSK):** A form of modulation in which binary data are transmitted by changing the carrier phase by 180 degrees. (See IEEE 802.3, Clause 11.)

**1.4.76 bit cell:** The time interval used for the transmission of a single data (CD0 or CD1) or control (CVH or CVL) symbol.

**1.4.77 bit error ratio (BER):** The ratio of the number of bits received in error to the total number of bits received.

**1.4.78 bit interleaved parity N (BIP-N):** A method of error monitoring using even (or odd) parity, such that an N-bit codeword is generated over a specified portion of an input data stream in such a manner that the i-th bit of the codeword provides even (or odd) parity over the i-th bit of all N-bit sequences in the covered portion of the data stream. This definition is derived from ANSI T1.416-1999 and ANSI T1.105-1995, which take precedence.

**1.4.79 bit rate (BR):** The total number of bits per second transferred to or from the Media Access Control (MAC). For example, 100BASE-T has a bit rate of one hundred million bits per second ( $10^8$  b/s).

**1.4.80 bit rate (BR)/2:** One-half of the BR in hertz.

**1.4.81 bit time (BT):** The duration of one bit as transferred to and from the Media Access Control (MAC). The bit time is the reciprocal of the bit rate. For example, for 100BASE-T the bit rate is  $10^{-8}$  s or 10 ns.

**1.4.82 BR/2:** See: bit rate (BR)/2.

**1.4.83 branch cable:** In 10BROAD36, the Attachment Unit Interface (AUI) cable interconnecting the data terminal equipment and Medium Attachment Unit (MAU) system components.

**1.4.84 bridge:** A layer 2 interconnection device that does not form part of a CSMA/CD collision domain but conforms to IEEE Std 802.1D. A bridge does not form part of a CSMA/CD collision domain but, rather appears as a Media Access Control (MAC) to the collision domain. (See also IEEE 100.)

**1.4.85 broadband local area network (LAN):** A local area network in which information is transmitted on modulated carriers, allowing coexistence of multiple simultaneous services on a single physical medium by frequency division multiplexing. (See IEEE 802.3, Clause 11.)

**1.4.86 bundle:** A group of signals that have a common set of characteristics and differ only in their information content.

**1.4.87 carrier extension:** The addition of non-data symbols to the end of frames that are less than slotTime bits in length so that the resulting transmission is at least one slotTime in duration.

**1.4.88 carrier sense:** In a local area network, an ongoing activity of a data station to detect whether another station is transmitting.

NOTE—The carrier sense signal indicates that one or more DTEs are currently transmitting.

**1.4.89 Category 3 balanced cabling:** Balanced 100  $\Omega$  and 120  $\Omega$  cables and associated connecting hardware whose transmission characteristics are specified up to 16 MHz (i.e., performance meets the requirements of a Class C link as per ISO/IEC 11801:1995). Commonly used by IEEE 802.3 10BASE-T installations. In addition to the requirements outlined in ISO/IEC 11801:1995, IEEE 802.3 Clause 14, Clause 23, and Clause 32 specify additional requirements for cabling when used with 10BASE-T, 100BASE-TX, and 1000BASE-T.

**1.4.90 Category 4 balanced cabling:** Balanced 100  $\Omega$  and 120  $\Omega$  cables and associated connecting hardware whose transmission characteristics are specified up to 20 MHz as per ISO/IEC 11801:1995. In addition to the requirements outlined in ISO/IEC 11801:1995, IEEE 802.3 Clause 14, Clause 23, and

Clause 32 specify additional requirements for this cabling when used with 10BASE-T, 100BASE-T4, and 100BASE-T2, respectively.

**1.4.91 Category 5 balanced cabling:** Balanced 100  $\Omega$  and 120  $\Omega$  cables and associated connecting hardware whose transmission characteristics are specified up to 100 MHz (i.e., cabling components meet the performance specified in ISO/IEC 11801:1995). In addition to the requirements outlined in ISO/IEC 11801:1995, IEEE 802.3 Clause 14, Clause 23, Clause 25, and Clause 40 specify additional requirements for this cabling when used with 10BASE-T and 100BASE-T.

**1.4.92 CATV-type broadband medium:** *See: Community Antenna Television (CATV)-type broadband medium.*

**1.4.93 center wavelength:** The average of two optical wavelengths at which the spectral radiant intensity is 50% of the maximum value. (See IEEE 802.3, Clause 11.)

**1.4.94 channel:** A band of frequencies dedicated to a certain service transmitted on the broadband medium. (See IEEE 802.3, Clause 11.)

**1.4.95 channel insertion loss:** As used in IEEE 802.3 Clause 38 for fiber optic links, the static loss of a link between a transmitter and receiver. It includes the loss of the fiber, connectors, and splices.

**1.4.96 chassis ground:** The electrical node that contains the chassis (see IEEE 100).

**1.4.97 circuit:** The physical medium on which signals are carried across the Attachment Unit Interface (AUI) for 10BASE-T or Media Independent Interface (MII) for 100BASE-T. For 10BASE-T, the data and control circuits consist of an A circuit and a B circuit forming a balanced transmission system so that the signal carrier on the B circuit is the inverse of the signal carried on the A circuit.

**1.4.98 Class I repeater:** A type of 100BASE-T repeater set with internal delay such that only one repeater set may exist between any two DTEs within a single collision domain when two maximum length copper cable segments are used. (See IEEE 802.3, Clause 27.)

**1.4.99 Class II repeater:** A type of IEEE 802.3 100BASE-T repeater set with internal delay such that only two or fewer such repeater sets may exist between any two DTEs within a single collision domain when two maximum length copper cable segments are used. (See IEEE 802.3, Clause 27.)

**1.4.100 Clocked Data One (CD1):** A Manchester-encoded data 1. A CD1 is encoded as a LO for the first half of the bit-cell and a HI for the second half of the bit-cell. (See IEEE 802.3, Clause 12.)

**1.4.101 Clocked Data Zero (CD0):** A Manchester-encoded data 0. A CD0 is encoded as a HI for the first half of the bit-cell and a LO for the second half of the bit-cell. (See IEEE 802.3, Clause 12.)

**1.4.102 Clocked Violation HI (CVH):** A symbol that deliberately violates Manchester-encoding rules, used as a part of the Collision Presence signal. A CVH is encoded as a transition from LO to HI at the beginning of the bit cell, HI for the entire bit cell, and a transition from HI to LO at the end of the bit cell. (See IEEE 802.3, Clause 12.)

**1.4.103 Clocked Violation LO (CVL):** A symbol that deliberately violates Manchester-encoding rules, used as a part of the Collision Presence signal. A CVL is encoded as a transition from HI to LO at the beginning of the bit cell, LO for the entire bit cell, and a transition from LO to HI at the end of the bit cell. (See IEEE 802.3, Clause 12.)

**1.4.104 coaxial cable:** A two-conductor (center conductor, shield system), concentric, constant impedance transmission line used as the trunk medium in the baseband system.

**1.4.105 coaxial cable interface:** The electrical and mechanical interface to the shared coaxial cable medium either contained within or connected to the Medium Attachment Unit (MAU). Also known as the Medium Dependent Interface (MDI).

**1.4.106 coaxial cable section:** A single length of coaxial cable, terminated at each end with a male BNC connector. Cable sections are joined to other cable sections via BNC plug/receptacle barrel or Type T adapters.

**1.4.107 coaxial cable segment:** A length of coaxial cable made up from one or more coaxial cable sections and coaxial connectors, and terminated at each end in its characteristic impedance.

**1.4.108 code-bit:** Within IEEE 802.3, in 100BASE-T, the unit of data passed across the Physical Medium Attachment (PMA) service interface, and the smallest signaling element used for transmission on the medium. A group of five code-bits constitutes a code-group in the 100BASE-X Physical Coding Sublayer (PCS). (See IEEE 802.3, Clause 24.)

**1.4.109 code-group:** For IEEE 802.3, a set of encoded symbols representing encoded data or control information. For 100BASE-T4, a set of six ternary symbols that, when representing data, conveys an octet. For 100BASE-TX and 100BASE-FX, a set of five code-bits that, when representing data, conveys a nibble. For 100BASE-T2, a pair of PAM5×5 symbols that, when representing data, conveys a nibble. For 1000BASE-X, a set of ten bits that, when representing data, conveys an octet. For 1000BASE-T, a vector of four 8B1Q4 coded quinary symbols that, when representing data, conveys an octet. (See IEEE 802.3, Clause 23, Clause 24, Clause 32, Clause 36, and Clause 40.)

**1.4.110 code-group alignment:** In 1000BASE-X, the receiver action that resets the existing code-group boundary to that of the comma or K28.5 character currently being received. (See IEEE 802.3, Clause 36.)

**1.4.111 code-group slipping:** In 1000BASE-X, the receiver action to align the correct receive clock and code-group containing a comma. (See IEEE 802.3, Clause 36.)

**1.4.112 Code Rule Violation (CRV):** An analog waveform that is not the result of the valid Manchester-encoded output of a single optical transmitter. The collision of two or more 10BASE-FB optical transmissions will cause multiple CRVs. The preamble encoding of a single 10BASE-FP optical transmission contains a single CRV. (See IEEE 802.3, 16.3.1.1.)

**1.4.113 collision:** A condition that results from concurrent transmissions from multiple data terminal equipment (DTE) sources within a single collision domain.

**1.4.114 collision domain:** A single, half duplex mode CSMA/CD network. If two or more Media Access Control (MAC) sublayers are within the same collision domain and both transmit at the same time, a collision will occur. MAC sublayers separated by a repeater are in the same collision domain. MAC sublayers separated by a bridge are within different collision domains. (See IEEE 802.3.)

**1.4.115 collision presence:** A signal generated within the Physical Layer by an end station or hub to indicate that multiple stations are contending for access to the transmission medium. (See IEEE 802.3, Clause 8 and Clause 12.)

**1.4.116 comma:** In 1000BASE-X, the seven-bit sequence that is part of an 8B/10B code-group that is used for the purpose of code-group alignment. (See IEEE 802.3, Clause 36.)

**1.4.117 comma-:** In 1000BASE-X, the seven-bit sequence (1100000) of an encoded data stream. (See IEEE 802.3, Clause 36.)

**1.4.118 comma+:** In 1000BASE-X, the seven-bit sequence (0011111) of an encoded data stream. (See IEEE 802.3, Clause 36.)

**1.4.119 common-mode voltage:** The instantaneous algebraic average of two signals applied to a balanced circuit, with both signals referenced to a common reference. Also called *longitudinal voltage* in the telephone industry.

**1.4.120 Community Antenna Television (CATV)-type broadband medium:** A broadband system comprising coaxial cables, taps, splitters, amplifiers, and connectors the same as those used in CATV or cable television installations. (See IEEE 802.3, Clause 11.)

**1.4.121 compatibility interfaces:** Several hardware points of attachment have been defined by this standard to allow connection of independently designed and manufactured components to the transmission medium. (See IEEE 802.3, 1.1.3.2.)

**1.4.122 container:** An SDH term that is equivalent to the payload capacity of a synchronous payload envelope. This definition is derived from ANSI T1.416-1999 and ANSI T1.105-1995, which take precedence.

**1.4.123 continuous wave (CW):** A carrier that is not modulated or switched.

**1.4.124 Control mode:** In 1000BASE-T, the period of operation in which the PHY is transmitting code-groups that represent control information. The end of a frame is accompanied by a transition to the Control mode, which immediately follows the Data mode and precedes the Idle mode. This occurs when the GMII signal TX\_EN is set FALSE. During this time, several control fields are transmitted as code-groups to complete a stream. These include two convolutional encoder reset code-groups, two End-of-Stream delimiter (ESD) code-groups and, possibly, carrier extend code-groups. (See IEEE 802.3, Clause 40.)

**1.4.125 Control Signal One (CS1):** An encoded control signal used on the Control In and Control Out circuits. A CS1 is encoded as a signal at half the bit rate (BR)/2). (See IEEE 802.3, Clause 7.)

**1.4.126 Control Signal Zero (CS0):** An encoded control signal used on the Control In and Control Out circuits. A CS0 is encoded as a signal at the bit rate (BR). (See IEEE 802.3, Clause 7.)

**1.4.127 Coupled Power Ratio (CPR):** The ratio (in dB) of the total power coupled into a multimode fiber to the optical power that can be coupled into a single-mode fiber.

**1.4.128 cross connect:** A group of connection points, often wall- or rack-mounted in a wiring closet, used to mechanically terminate and interconnect twisted-pair building wiring.

**1.4.129 data frame:** Use of this term is restricted to Clause 9, 27 and 41 (*See: MAC Frame*).

**1.4.130 Data mode:** In 1000BASE-T, the period of operation in which the PHY is transmitting code-groups that represent data. This mode is preceded by a start of a frame during which the GMII signal TX\_EN is set TRUE for data transmission. This mode begins with transmission of two Start-of-Stream delimiter code-groups followed by code-groups encoded from the data octets arriving on TXD<7:0> via the GMII. (See IEEE 802.3 Clause 40.)

**1.4.131 data terminal equipment (DTE):** Any source or destination of data connected to the local area network.

**1.4.132 dBm:** Decibels referenced to 1.0 mW.

**1.4.133 dBmV:** Decibels referenced to 1.0 mV measured at the same impedance. Used to define signal levels in Community Antenna Television (CATV)-type broadband systems. (See IEEE 802.3 Clause 11.)

**1.4.134 dedicated service:** A CSMA/CD network in which the collision domain consists of two and only two DTEs so that the total network bandwidth is dedicated to supporting the flow of information between them.

**1.4.135 defect:** A limited interruption in the ability of an item to perform a required function. This definition is derived from ANSI T1.416-1999 and ANSI T1.105-1995, which take precedence.

**1.4.136 differential Manchester encoding:** Data encoding system used in Backplane Ethernet for Auto-Negotiation signaling and 10GBASE-KR training frame control channel encoding. (See IEEE 802.3 72.6.10.2.2 and 73.5.)

**1.4.137 differential-mode voltage:** The instantaneous algebraic difference between the potential of two signals applied to the two sides of a balanced circuit. Also called *metallic voltage* in the telephone industry.

**1.4.138 differential skew:** The difference in time between the midpoint voltage crossings of the true and complement components of a differential signal.

**1.4.139 dispersion slope:** The rate of change of the chromatic dispersion of a fiber with wavelength.

**1.4.140 Downstream:** In an access network, where there is a clear indication in each deployment as to which end of a link is closer to a subscriber, transmission toward the subscriber end of the link.

**1.4.141 drop cable:** In 10BROAD36, the small diameter flexible coaxial cable of the broadband medium that connects to a Medium Attachment Unit (MAU). (See: **trunk cable**.)

**1.4.142 DSQ128:** The 128 point double square (DSQ) constellation mapping used in 10GBASE-T. This constellation is obtained by taking a 2D constellation with 16-level pulse amplitude modulation (PAM16) on each dimension and eliminating half the points to create a checkerboard pattern. This constellation is based on a lattice called  $RZ^2$  in the literature. (See IEEE Std 802.3, Clause 55.)

NOTE—See also Forney [B28A]

**1.4.143 dual duplex:** Within IEEE 802.3, a signaling system that supports simultaneous duplex communication over two cabling pairs.

**1.4.144 duplex channel:** Within IEEE 802.3, a communications channel capable of simultaneous duplex communication.

**1.4.145 eight-pin modular:** An eight-wire connector. (From IEC 60603-7.)

**1.4.146 encapsulation:** In 1000BASE-X, the process by which a MAC packet is enclosed within a PCS code-group stream. (See IEEE 802.3, Clause 36.)

**1.4.147 encircled flux:** The optical power within a specified radius of a fiber center, as a percentage of that within 36  $\mu\text{m}$  (for 62.5  $\mu\text{m}$  fiber) or 29  $\mu\text{m}$  (for 50  $\mu\text{m}$  fiber).

**1.4.148 Endpoint PSE:** Power Sourcing Equipment (PSE) that is located at an endpoint.

**1.4.149 End\_of\_Packet Delimiter (EPD):** In 1000BASE-X, a defined sequence of three single code-group 8B/10B ordered sets used to delineate the ending boundary of a data transmission sequence for a single packet. (See IEEE 802.3, Clause 36.)

**1.4.150 End-of-Stream Delimiter (ESD):** Within IEEE 802.3, a code-group pattern used to terminate a normal data transmission. For 100BASE-T4, the ESD is indicated by the transmission of five predefined ternary

code-groups named eop1-5. For 100BASE-X, the ESD is indicated by the transmission of the code-group/T/R. For 100BASE-T2, the ESD is indicated by two consecutive pairs of predefined PAM5×5 symbols (see Table 32–15), which are generated using unique Start-of-Stream Delimiter (SSD)/ESD coding rules. For 1000BASE-T, the ESD is indicated by two consecutive vectors of four quinary symbols as specified in Table 40–1. (See IEEE 802.3, Clause 22, Clause 23, Clause 32, and Clause 40.)

**1.4.151 envelope frame:** A MAC frame that carries a Length/Type field with the Type interpretation that may indicate additional encapsulation information within the MAC client data and has a maximum length of 2000 octets. The envelope frame is intended to allow inclusion of additional prefixes and suffixes required by higher layer encapsulation protocols. The encapsulation protocols may use up to 482 octets. (See IEEE 802.3, 3.2.7.)

**1.4.152 EtherType:** *See: Type.*

**1.4.153 Exception Window:** A time interval during which the impedance of a mated connector and associated transmission line is allowed to exceed the impedance tolerance specification for signals passed through that connector.

**1.4.154 extension bit:** A bit decoded from the received carrier stream that does not map into the data space but nonetheless denotes the presence of carrier for the purposes of CSMA/CD.

**1.4.155 extinction ratio:** The ratio of the low optical power level to the high optical power level on an optical segment. (See IEEE 802.3, Clause 15.)

**1.4.156 eye-opening penalty:** The difference, in dB, between (a) the optical power measured at the center of the data eye, and (b) the optical power measured at a point defined by the total worst-case peak-to-peak jitter at the receiver.

**1.4.157 Fast Link Pulse (FLP) Burst:** A group of no more than 33 and not less than 17 10BASE-T compatible link integrity test pulses. Each FLP Burst encodes 16 bits of data using an alternating clock and data pulse sequence. (See Figure 14–14, IEEE 802.3, Clause 14 and Figure 28–4, IEEE 802.3, Clause 28.)

**1.4.158 Fast Link Pulse (FLP) Burst Sequence:** The sequence of FLP Bursts transmitted by the local station. This term is intended to differentiate the spacing between FLP Bursts from the individual pulse spacings within an FLP Burst. (See IEEE 802.3, Clause 28.)

**1.4.159 fiber optic cable:** A cable containing one or more optical fibers as specified in IEEE 802.3, 15.3.1.

**1.4.160 Fiber Optic Inter-Repeater Link (FOIRL):** A Fiber Optic Inter-Repeater Link segment and its two attached Medium Attachment Units (MAUs). (See IEEE 802.3, Clause 15.)

**1.4.161 Fiber Optic Inter-Repeater Link (FOIRL) bit error ratio (BER):** For 10BASE-F, the mean bit error ratio of the FOIRL. (See IEEE 802.3, Clause 9.)

**1.4.162 Fiber Optic Inter-Repeater Link (FOIRL) collision:** For 10BASE-F, the simultaneous transmission and reception of data in a Fiber Optic Medium Attachment Unit (FOMAU). (See IEEE 802.3, Clause 9.)

**1.4.163 Fiber Optic Inter-Repeater Link (FOIRL) Compatibility Interface:** For 10BASE-F, the FOMDI and Attachment Unit Interface (AUI) (optional); the two points at which hardware compatibility is defined to allow connection of independently designed and manufactured components to the baseband optical fiber cable link segment. (See IEEE 802.3, Clause 9.)

**1.4.164 Fiber Optic Inter-Repeater Link (FOIRL) Segment:** A fiber optic link segment providing a point-to-point connection between two FOIRL Medium Attachment Units (MAUs) or between one FOIRL MAU and one 10BASE-FL MAU. *See: link segment.*

**1.4.165 Fiber Optic Medium Attachment Unit (FOMAU):** A MAU for fiber applications. (See IEEE 802.3, Clause 9.)

**1.4.166 Fiber Optic Medium Attachment Unit's (FOMAU's) Receive Optical Fiber:** For 10BASE-F, the optical fiber from which the local FOMAU receives signals. (See IEEE 802.3, Clause 9.)

**1.4.167 Fiber Optic Medium Attachment Unit's (FOMAU's) Transmit Optical Fiber:** For 10BASE-F, the optical fiber into which the local FOMAU transmits signals. (See IEEE 802.3, Clause 9.)

**1.4.168 Fiber Optic Medium Dependent Interface (FOMDI):** For 10BASE-F, the mechanical and optical interface between the optical fiber cable link segment and the Fiber Optic Medium Attachment Unit (FOMAU). (See IEEE 802.3, Clause 9.)

**1.4.169 Fiber Optic Physical Medium Attachment (FOPMA):** For 10BASE-F, the portion of the Fiber Optic Medium Attachment Unit (FOMAU) that contains the functional circuitry. (See IEEE 802.3 Clause 9.)

**1.4.170 fiber pair:** Optical fibers interconnected to provide two continuous light paths terminated at each end in an optical connector. Any intermediate optical connections must have insertion and return loss characteristics that meet or exceed IEEE 802.3, 15.3.2.1 and 15.3.2.2, respectively. (See IEEE 802.3, 15.3.1.)

**1.4.171 Fibre Channel (FC-PH):** Name used to refer to ANSI X3.230-1994 [B22]. (See IEEE 802.3, Clause 36.)

**1.4.172 Fibre Distributed Data Interface (FDDI):** A 100 Mb/s, fiber optic-based, token-ring local area network standard (ISO/IEC 9314 series of standards).

**1.4.173 fixed stuff:** Null or padding octets inserted to compensate for the bandwidth differences between the byte interleaving and the concatenation rules of SONET/SDH. This definition is derived from ANSI T1.416-1999 and ANSI T1.105-1995, which take precedence.

**1.4.174 FLP Burst:** *See: Fast Link Pulse (FLP) Burst.*

**1.4.175 FOIRL:** *See: Fiber Optic Inter-Repeater Link (FOIRL).*

**1.4.176 FOMAU:** *See: Fiber Optic Medium Attachment Unit (FOMAU).*

**1.4.177 frame ground:** *See: chassis ground.*

**1.4.178 full duplex:** A mode of operation of a network, DTE, or Medium Attachment Unit (MAU) that supports duplex transmission as defined in IEEE 100. Within the scope of this standard, this mode of operation allows for simultaneous communication between a pair of stations, provided that the Physical Layer is capable of supporting simultaneous transmission and reception without interference. (See IEEE 802.3.)

**1.4.179 Gigabit Media Independent Interface (GMII):** The interface between the Reconciliation sublayer and the physical coding sublayer (PCS) for 1000 Mb/s operation. (See IEEE 802.3, Clause 35.)

**1.4.180 grant:** Within P2MP protocols, a permission to transmit at a specific time, for a specific duration. Grants are issued by the OLT (master) to ONUs (slaves) by means of GATE messages.



**1.4.181 group:** A repeater port or a collection of repeater ports that can be related to the logical arrangement of ports within a repeater.

**1.4.182 group delay:** In 10BROAD36, the rate of change of total phase shift, with respect to frequency, through a component or system. Group delay variation is the maximum difference in delay as a function of frequency over a band of frequencies. (See IEEE 802.3, Clause 11.)

**1.4.183 half duplex:** A mode of operation of a CSMA/CD local area network (LAN) in which DTEs contend for access to a shared medium. Multiple, simultaneous transmissions in a half duplex mode CSMA/CD LAN result in interference, requiring resolution by the CSMA/CD access control protocol. (See IEEE 802.3.)

**1.4.184 headend:** In 10BROAD36, the location in a broadband system that serves as the root for the branching tree comprising the physical medium; the point to which all inbound signals converge and the point from which all outbound signals emanate. (See IEEE 802.3, Clause 11.)

**1.4.185 header hub (HH):** The highest-level hub in a hierarchy of hubs. The HH broadcasts signals transmitted to it by lower-level hubs or DTEs such that they can be received by all DTEs that may be connected to it either directly or through intermediate hubs. (See IEEE 802.3, 12.2.1.)

**1.4.186 hub:** A device used to provide connectivity between DTEs. Hubs perform the basic functions of restoring signal amplitude and timing, collision detection, and notification and signal broadcast to lower-level hubs and DTEs. (See IEEE 802.3, Clause 12.)

**1.4.187 hybrid:** A circuit (implementable with active or passive components) that enables full duplex transmission by allowing symbols to be transmitted and received on the same wire pair at the same time. It is often used together with an echo canceller to get adequate separation of transmit and receive signals.

**1.4.188 idle (IDL):** A signal condition where no transition occurs on the transmission line, that is used to define the end of a frame and ceases to exist after the next LO or HI transition on the Attachment Unit Interface (AUI) or Media Independent Interface (MII) circuits. An IDL always begins with a HI signal level. A driver is required to send the IDL signal for at least 2 bit times and a receiver is required to detect IDL within 1.6 bit times. (See IEEE 802.3, 7.3 and 12.3.2.4.4 for additional details.)

**1.4.189 Idle mode:** In 1000BASE-T, the period of operation in which the PHY is transmitting special code-groups that use only the values  $\{2, 0, -2\}$ . Idle mode occurs during start-up when the PHYs at each end of a link are attempting to establish adaptive filter parameters and then synchronize both phase and timing so that normal operation can begin. Idle mode also occurs during normal operation between frames. Idle mode occurs after a control mode ends and before another Data mode begins. The Idle mode is not used between frames in a packet burst. (See IEEE 802.3, Clause 40.)

**1.4.190 in-band signaling:** The transmission of a signal using a frequency that is within the bandwidth of the information channel. *Contrast with:* **out-of-band signaling**. *Syn:* **in-channel signaling**. (From IEEE Std 610.7-1995 [B44].)

**1.4.191 intermediate hub (IH):** A hub that occupies any level below the header hub in a hierarchy of hubs. (See IEEE 802.3, 12.2.1 for details.)

**1.4.192 Inter-Packet Gap (IPG):** A delay or time gap between CSMA/CD packets intended to provide interframe recovery time for other CSMA/CD sublayers and for the Physical Medium. (See IEEE 802.3, 4.2.3.2.1 and 4.2.3.2.2.) For example, for 10BASE-T, the IPG is 9.6  $\mu$ s (96 bit times); for 100BASE-T, the IPG is 0.96  $\mu$ s (96 bit times).

**1.4.193 Inter-Repeater Link (IRL):** A mechanism for connecting two and only two repeater sets.

**1.4.194 intersymbol interference penalty:** The power penalty due to the finite bandwidth of the link. (See IEEE 802.3, Clause 38.)

**1.4.195 jabber:** A condition wherein a station transmits for a period of time longer than the maximum permissible packet length, usually due to a fault condition.

**1.4.196 Jabber function:** A mechanism for controlling abnormally long transmissions (i.e., jabber).

**1.4.197 jitter:** The variations of signal transitions from their ideal positions in time. Jitter may be characterized by its spectral properties and its distribution in time.

**1.4.198 jumper cable assembly:** An electrical or optical assembly, used for the bidirectional transmission and reception of information, consisting of a pair of transmission lines terminated at their ends with plug connectors. This assembly may or may not contain additional components, located between the plug connectors, to perform equalization. (See IEEE 802.3, Clause 39.)

**1.4.199 lane:** A bundle of signals that constitutes a logical subset of a point-to-point interconnect. A lane contains enough signals to communicate a quantum of data and/or control information between the two endpoints.

**1.4.200 LDPC(1723,2048) frame:** 64B/65B transmission code blocks mapped into a low density parity check (LDPC) frame with 1723 coded bits, 325 check bits and 1536 uncoded bits. (See IEEE 802.3, Clause 55.)

**1.4.201 link:** The transmission path between any two interfaces of generic cabling. (From ISO/IEC 11801.)

**1.4.202 Link codeword:** The 16 bits of data encoded into a Fast Link Pulse (FLP) Burst. (See IEEE 802.3, Clause 28.)

**1.4.203 link partner:** The device at the opposite end of a link segment from the local station. The link partner device may be either a DTE or a repeater. (See IEEE 802.3, Clause 28.)

**1.4.204 link penalties:** For fiber optic links, the power penalties of a link not attributed to link attenuation. These power penalties include modal noise, relative intensity noise (RIN), intersymbol interference (ISI), mode partition noise, extinction ratio, and eye-opening penalties.

**1.4.205 link pulse:** Communication mechanism used in 10BASE-T and 100BASE-T networks to indicate link status and (in Auto-Negotiation-equipped devices) to communicate information about abilities and negotiate communication methods. 10BASE-T uses Normal Link Pulses (NLPs), which indicate link status only. 10BASE-T and 100BASE-T nodes equipped with Auto-Negotiation exchange information using a Fast Link Pulse (FLP) mechanism that is compatible with NLP. (See IEEE 802.3, Clause 14 and Clause 28.)

**1.4.206 link section:** The portion of the link from the PSE to the PD.

**1.4.207 link segment:** The point-to-point full-duplex medium connection between two and only two Medium Dependent Interfaces (MDIs).

**1.4.208 Link Segment Delay Value (LSDV):** A number associated with a given segment that represents the delay on that segment used to assess path delays for 100 Mb/s CSMA/CD networks. LSDV is similar to SDV; however, LSDV values do not include the delays associated with attached end stations and/or repeaters. (See IEEE 802.3, 29.3.)

**1.4.209 local ability:** *See: ability.*

**1.4.210 local device:** The local device that may attempt to perform Auto-Negotiation with a link partner. The local device may be either a DTE or repeater. (See IEEE 802.3, Clause 28.)

**1.4.211 Logical Link Identifier (LLID):** A numeric identifier assigned to a P2MP association between an OLT and ONU established through the Point-to-Point Emulation sublayer. Each P2MP association is assigned a unique LLID. The P2MP association is bound to an ONU DTE, where a MAC would observe a private association.

**1.4.212 MAC frame:** Consists of the Destination Address, Source Address, Length/Type field, MAC Client Data, Pad (if required), and Frame Check Sequence.

**1.4.213 Management Information Base (MIB):** A repository of information to describe the operation of a specific network device.

**1.4.214 management interface:** An interface provided by both the Media Independent Interface (MII) or Gigabit Media Independent Interface (GMII) that provides access to management parameters and services.

**1.4.215 master Physical Layer (PHY):** Within IEEE 802.3, in a 100BASE-T2 or 1000BASE-T link containing a pair of PHYs, the PHY that uses an external clock for generating its clock signals to determine the timing of transmitter and receiver operations. It also uses the master transmit scrambler generator polynomial for side-stream scrambling. Master and slave PHY status is determined during the Auto-Negotiation process that takes place prior to establishing the transmission link. *See also: slave Physical Layer (PHY).*

**1.4.216 maximum differential input:** The largest value of peak-to-peak differential (ppd) amplitude at which a receiver is expected to operate, under worst-case conditions, without exceeding the objective bit error ratio.

**1.4.217 Media Access Control (MAC):** The data link sublayer that is responsible for transferring data to and from the Physical Layer.

**1.4.218 Media Independent Interface (MII):** A transparent signal interface at the bottom of the Reconciliation sublayer. (See IEEE 802.3, Clause 22.)

**1.4.219 Medium Attachment Unit (MAU):** A device containing an Attachment Unit Interface (AUI), Physical Medium Attachment (PMA), and Medium Dependent Interface (MDI) that is used to connect a repeater or data terminal equipment (DTE) to a transmission medium.

**1.4.220 Medium Dependent Interface (MDI):** The mechanical and electrical or optical interface between the transmission medium and the MAU (e.g., 10BASE-T) or the PHY (e.g., 1000BASE-T) and also between the transmission medium and any associated (optional per IEEE 802.3, Clause 33) Powered Device (PD) or Endpoint Power Sourcing Equipment (PSE).

**1.4.221 Message Code (MC):** The predefined 12-bit code contained in an Auto-Negotiation Message Page. (See IEEE 802.3, Clause 28.)

**1.4.222 Message Page (MP):** An Auto-Negotiation next page encoding that contains a predefined 12-bit Message Code. (See IEEE 802.3, Clause 28.)

**1.4.223 midspan:** An entity located within a link segment that is distinctly separate from and between the Medium Dependent Interfaces (MDIs).

**1.4.224 Midspan PSE:** Power Sourcing Equipment (PSE) that is located in the midspan.

**1.4.225 minimum differential sensitivity:** The smallest value of peak-to-peak differential (ppd) amplitude at which a receiver is expected to operate, under worst-case conditions, without exceeding the objective bit error ratio.

**1.4.226 mixing segment:** A medium that may be connected to more than two Medium Dependent Interfaces (MDIs).

**1.4.227 multiport device:** A device with multiple instances of MDI. (See IEEE 802.3, Clause 40 and Clause 42.)

**1.4.228 network control host:** A network management central control center that is used to configure agents, communicate with agents, and display information collected from agents.

**1.4.229 network interface device (NID):** A device that contains a MDI or a PI.

**1.4.230 next page:** General class of pages optionally transmitted by Auto-Negotiation able devices following the base link codeword negotiation. (See IEEE 802.3, Clause 28.)

**1.4.231 next page algorithm (NPA):** The algorithm that governs next page communication. (See IEEE 802.3, Clause 28.)

**1.4.232 Next Page bit:** A bit in the Auto-Negotiation base link codeword or next page encoding(s) that indicates that further link codeword transfer is required. (See IEEE 802.3, Clause 28.)

**1.4.233 nibble:** A group of four data bits. The unit of data exchange on the Media Independent Interface (MII). (See IEEE 802.3, Clause 22.)

**1.4.234 NLP:** *See:* **Normal Link Pulse (NLP).**

**1.4.235 Non-Return-to-Zero, Invert on Ones (NRZI):** An encoding technique used in FDDI (ISO/IEC 9314-1:1989, ISO/IEC 9314-2:1989, ISO/IEC 9314-3:1989) where a polarity transition represents a logical ONE. The absence of a polarity transition denotes a logical ZERO.

**1.4.236 Non-Return-to-Zero, Invert on Ones (NRZI)-bit:** A code-bit transferred in NRZI format. The unit of data passed across the Physical Medium Dependent (PMD) service interface in 100BASE-X.

**1.4.237 normalized amplitude:** The amplitude of a signal when driving its steady-state value; i.e., not under the influence of ringing or other dynamic influences.

**1.4.238 Normal Link Pulse (NLP):** An out-of-band communications mechanism used in 10BASE-T to indicate link status. (See IEEE 802.3, Figure 14–12.)

**1.4.239 Normal Link Pulse (NLP) Receive Link Integrity Test function:** A test function associated with Auto-Negotiation that allows backward compatibility with the 10BASE-T Link Integrity Test function of IEEE 802.3 Figure 14–6. (See IEEE 802.3, Clause 28.)

**1.4.240 Normal Link Pulse (NLP) sequence:** A Normal Link Pulse sequence, defined in IEEE 802.3, 14.2.1.1 as TP\_IDL.

**1.4.241 NRZI:** *See:* **Non-Return-to-Zero, Invert on Ones.**

**1.4.242 OAM Discovery:** Process that detects the presence and configuration of the OAM sublayer in the remote DTE.

**1.4.243 offline:** In 1000BASE-X, a DTE in its nonfunctional state. (See IEEE 802.3, Clause 37.)

**1.4.244 Operations, Administration, and Maintenance (OAM):** A group of network support functions that monitor and sustain segment operation, activities that are concerned with, but not limited to, failure detection, notification, location, and repairs that are intended to eliminate faults and keep a segment in an operational state and support activities required to provide the services of a subscriber access network to users/subscribers.

**1.4.245 optical fiber:** A filament-shaped optical waveguide made of dielectric materials.

**1.4.246 Optical Fiber Cable Interface:** *See:* **Fiber Optic Medium Dependent Interface (FOMDI).**

**1.4.247 optical fiber cable link segment:** A length of optical fiber cable that contains two optical fibers and is comprised of one or more optical fiber cable sections and their means of interconnection, with each optical fiber terminated at each end in the optical connector plug. (See IEEE 802.3, 9.9.5.1 and 9.9.5.1.)

**1.4.248 Optical Idle Signal:** The signal transmitted by the Fiber Optic Medium Attachment Unit (FOMAU) into its transmit optical fiber during the idle state of the DO circuit. (See IEEE 802.3, Clause 9.)

**1.4.249 optical interface:** The optical input and output connection interface to a 10BASE-FP Star. (See IEEE 802.3, Clause 15.)

**1.4.250 Optical Line Terminal (OLT):** The network-end DTE for an optical access network. The OLT is the master entity in a P2MP network with regard to the MPCP protocol.

**1.4.251 Optical Modulation Amplitude (OMA):** The absolute difference between the optical power of a logic one level and the optical power of a logic zero level.

**1.4.252 Optical Network Unit (ONU):** The subscriber-end DTE to an optical access network. An ONU is a slave entity in a P2MP network with regard to the MPCP protocol.

**1.4.253 ordered\_set:** As used in the 1000BASE-X PCS, a single special code-group, or a combination of special and data code-groups, used for the delineation of a packet and synchronization between the transmitter and receiver circuits at opposite ends of a link. (See IEEE 802.3, Clause 36.)

**1.4.254 out-of-band signaling:** The transmission of a signal using a frequency that is within the pass band of the transmission facility but outside a frequency range normally used for data transmission. *Contrast with:* **in-band signaling.** (From IEEE Std 610.7-1995 [B44].)

**1.4.255 overfilled launch:** The overfilled launch condition that excites both radial and azimuthal modes defined in ANSI/EIA/TIA 455-54A-1990 [B7].

**1.4.256 P2MP Discovery:** Process by which the OLT finds a newly attached and active ONU in the P2MP network, and by which the OLT and ONU exchange registration information. The OLT sends a GATE flagged for discovery.

**1.4.257 P2MP Discovery window:** A time period in a given wavelength band reserved by the OLT exclusively for the discovery process.

**1.4.258 P2MP Timestamp:** The timestamp used to synchronize slaves (e.g., ONUs) with the master (OLT) and for the ranging process.

**1.4.259 packet:** Consists of a MAC frame as defined previously, preceded by the Preamble and the Start Frame Delimiter, encoded, as appropriate, for the Physical Layer (PHY) type.

**1.4.260 page:** In Auto-Negotiation, the encoding for a link codeword. Auto-Negotiation can support an arbitrary number of link codeword encodings. The base page has a constant encoding as defined in 28.2.1.2. Additional pages may have a predefined encoding (*see: Message Page*) or may be custom encoded (*see: Unformatted Page*).

**1.4.261 PAM5×5:** Within IEEE 802.3, a block coding technique utilizing a 5×5 matrix (representing two 5-level signals) to generate pairs of quinary codes representing data nibbles and control characters. In 100BASE-T2, PAM5×5 code pairs are sent in parallel across two wire pairs. (See IEEE 802.3, Clause 32.)

**1.4.262 parallel detection:** In Auto-Negotiation, the ability to detect 100BASE-TX and 100BASE-T4 technology specific link signaling while also detecting the Normal Link Pulse (NLP) sequence or Fast Link Pulse (FLP) Burst sequence. (See IEEE 802.3, Clause 28.)

**1.4.263 Passive-Star Coupler:** A component of a 10BASE-FP fiber optic mixing segment that divides optical power received at any of N input ports among all N output ports. The division of optical power is approximately uniform. (See IEEE 802.3, Clause 15.)

**1.4.264 patch cord:** Flexible cable unit or element with connector(s) used to establish connections on a patch panel. (From ISO/IEC 11801:1995.)

**1.4.265 patch panel:** A cross-connect designed to accommodate the use of patch cords. It facilitates administration for moves and changes. (From ISO/IEC 11801:1995.)

**1.4.266 path:** The sequence of segments and repeaters providing the connectivity between two DTEs in a single collision domain. In CSMA/CD networks there is one and only one path between any two DTEs.

**1.4.267 Path Delay Value (PDV):** The sum of all Segment Delay Values for all segments along a given path. (See IEEE 802.3, Clause 13 and Clause 29.)

**1.4.268 Path Variability Value (PVV):** The sum of all Segment Variability Values for all the segments along a given path. (See IEEE 802.3, Clause 13.)

**1.4.269 pause:** A mechanism for full duplex flow control. (See IEEE 802.3, Annex 31B.)

**1.4.270 payload pointer:** An indicator of the location of the beginning of the synchronous payload envelope. This definition is derived from ANSI T1.416-1999 and ANSI T1.105-1995, which take precedence.

**1.4.271 Physical Coding Sublayer (PCS):** Within IEEE 802.3, a sublayer used in certain port types to couple the Media Independent Interface (MII), Gigabit Media Independent Interface (GMII) or 10 Gigabit Media Independent Interface (XGMII) and the Physical Medium Attachment (PMA). The PCS contains the functions to encode data bits for transmission via the PMA and to decode the received conditioned signal from the PMA. There are several PCS structures. (For example, see IEEE 802.3, Clause 23, Clause 24, Clause 32, Clause 36, Clause 40, Clause 48, and Clause 49.)

**1.4.272 Physical Layer entity (PHY):** Within IEEE 802.3, the portion of the Physical Layer between the Medium Dependent Interface (MDI) and the Media Independent Interface (MII), Gigabit Media Independent Interface (GMII) or 10 Gigabit Media Independent Interface (XGMII), consisting of the Physical Coding Sublayer (PCS), the Physical Medium Attachment (PMA), and, if present, the WAN Interface Sublayer (WIS) and Physical Medium Dependent (PMD) sublayers. The PHY contains the functions that transmit, receive, and manage the encoded signals that are impressed on and recovered from the physical medium. (For example, see IEEE 802.3, Clauses 23–26, Clause 32, Clause 36, Clause 40, Clauses 48–54, Clauses 58–63, Clause 65, and Clause 66.)

**1.4.273 Physical Medium Attachment (PMA) sublayer:** Within 802.3, that portion of the Physical Layer that contains the functions for transmission, reception, and (depending on the PHY) collision detection, clock recovery and skew alignment. (For example, see IEEE 802.3, Clauses 7, 12, 14, 16, 17, 18, 23, 24, 32, 36, 40, 51, 62, 63 and 66.)

**1.4.274 Physical Medium Dependent (PMD) sublayer:** Within 802.3, that portion of the Physical Layer responsible for interfacing to the transmission medium. The PMD is located just above the Medium Dependent Interface (MDI). (For example, see IEEE 802.3, Clause 25, Clause 26, Clause 38, Clause 39, Clause 54, Clauses 58-60, Clause 62, and Clause 63.)

**1.4.275 Physical Signaling Sublayer (PLS):** In 10BASE-T, that portion of the Physical Layer contained within the data terminal equipment (DTE) that provides the logical and functional coupling between the Medium Attachment Unit (MAU) and the Data Link Layer.

**1.4.276 Point-to-Multipoint network (P2MP):** A passive optical network providing transport of Ethernet frames (See IEEE 802.3, Clause 64 and Clause 65).

**1.4.277 pointer:** *See: payload pointer.*

**1.4.278 Point-to-point emulation (P2PE):** Emulation of private communication between two end-stations (e.g., ONU) in a P2MP. Emulation creates the equivalent of a star topology with the OLT in the nexus, and is required for compliance with IEEE 802.1D bridging.

**1.4.279 port:** A segment or Inter-Repeater Link (IRL) interface of a repeater unit.

**1.4.280 postamble:** In 10BROAD36, the bit pattern appended after the last bit of the Frame Check Sequence by the Medium Attachment Unit (MAU). The Broadband End-of-Frame Delimiter (BEOFD). (See IEEE 802.3, Clause 11.)

**1.4.281 power budget:** The minimum optical power available to overcome the sum of attenuation plus power penalties of the optical path between the transmitter and receiver calculated as the difference between the transmitter launch power (min) and the receive power (min).

**1.4.282 Power Interface (PI):** The mechanical and electrical interface between the Power Sourcing Equipment (PSE) or Powered Device (PD) and the transmission medium. In an Endpoint PSE and in a PD the Power Interface is the MDI.

**1.4.283 Power Sourcing Equipment (PSE):** A DTE or midspan device that provides the power to a single link section. DTE powering is intended to provide a single 10BASE-T, 100BASE-TX, or 1000BASE-T device with a unified interface for both the data it requires and the power to process these data.

**1.4.284 Powered Device (PD):** A device that is either drawing power or requesting power from a PSE.

**1.4.285 prepend:** To append to the beginning. For example, a Media Access Control (MAC) frame is prepended with a preamble, and appended with a frame check sequence (FCS).

**1.4.286 priority resolution:** A mechanism that allows a local device and its link partner to resolve to a single mode of operation given a set of prioritized rules governing resolution. (See IEEE 802.3, Clause 28 and Clause 37.)

**1.4.287 Priority Resolution Table:** The look-up table used by Auto-Negotiation to select the network connection type where more than one common network ability exists (100BASE-TX, 100BASE-T4, 10BASE-T, etc.) The priority resolution table defines the relative hierarchy of connection types from the highest common denominator to the lowest common denominator. (See IEEE 802.3, Clause 28.)

**1.4.288 PSE Group:** A PSE or a collection of PSEs that can be related to the logical arrangement for management within an encompassing system.

**1.4.289 Q:** In the context of a fiber optic communication system, one-half of the ratio of peak-to-peak signal to rms noise.

**1.4.290 QTag Prefix:** The first four octets of an Ethernet-encoded Tag Header. The Ethernet-encoded Tag Header is defined in IEEE 802.1Q.

**1.4.291 Q-tagged frame:** A MAC frame with a specific Type value, and that has a maximum length of 1522 octets. (See IEEE 802.3, 3.2.7 and IEEE 802.1Q, Annex C.)

**1.4.292 quad:** *See: star quad.*

**1.4.293 quinary:** Five-level.

**1.4.294 quinary symbol:** In 1000BASE-T, one of five numeric values corresponding to five voltage levels on a single balanced twisted pair. The values come from the set {2, 1, 0, -1, -2}. Table 40-1 lists groups of four quinary symbols. Idle is a special case where numeric values are limited to the set {2, 0, and -2}. (See IEEE 802.3, Clause 40.)

**1.4.295 radial overfilled launch:** A launch condition created when a multimode optical fiber is illuminated by the coherent optical output of a source operating in its lowest-order transverse mode in a manner that excites predominantly the radial modes of the multimode fiber.

**1.4.296 ranging:** A procedure by which the propagation delay between a master (e.g., OLT) and slave (e.g., ONU) is measured. The round trip delay computation is performed by the OLT, using the timestamp in MPCP messages from the ONU.

**1.4.297 receiver training:** Within IEEE 802.3, a start-up routine in 100BASE-T2 and 1000BASE-T used to acquire receiver parameters and synchronize the scramblers of two connected Physical Layers (PHYs).

**1.4.298 Reconciliation Sublayer (RS):** A 100BASE-T mapping function that reconciles the signals at the Media Independent Interface (MII) to the Media Access Control (MAC)-Physical Signaling Sublayer (PLS) service definitions. (See IEEE 802.3, Clause 22.)

**1.4.299 reflectance:** Ratio of reflected to incident power. This is the inverse of return loss.

**1.4.300 relative intensity noise:** The ratio of the variance in the optical power to the average optical power.

**1.4.301 remote fault:** The generic ability of a link partner to signal its status even in the event that it may not have an operational receive link. (See IEEE 802.3, Clause 28 and Clause 37.)

**1.4.302 renegotiation:** Restart of the Auto-Negotiation algorithm caused by management or user interaction. (See IEEE 802.3, Clause 28.)

**1.4.303 repeater:** Within IEEE 802.3, a device as specified in Clause 9 and Clause 27 that is used to extend the length, topology, or interconnectivity of the physical medium beyond that imposed by a single segment, up to the maximum allowable end-to-end transmission line length. Repeaters perform the basic actions of restoring signal amplitude, waveform, and timing applied to the normal data and collision signals. For wired star topologies, repeaters provide a data distribution function. In 100BASE-T, a device that allows the interconnection of 100BASE-T Physical Layer (PHY) network segments using similar or dissimilar PHY implementations (e.g., 100BASE-X to 100BASE-X, 100BASE-X to 100BASE-T4). Repeaters are only for use in half duplex mode networks. (See IEEE 802.3, Clause 9 and Clause 27.)



**1.4.304 repeater port:** *See: port.*

**1.4.305 repeater set:** A repeater unit plus its associated Physical Layer interfaces [Medium Attachment Units (MAUs) or PHYs] and, if present, Attachment Unit (AU) or Media Independent (MI) interfaces (i.e., AUIs, MIIs).

**1.4.306 repeater unit:** The portion of a repeater that is inboard of its Physical Medium Attachment (PMA)/Physical Signaling Sublayer (PLS), or PMA/Physical Coding Sublayer (PCS) interfaces.

**1.4.307 retraining:** Within IEEE 802.3, the process of re-acquiring receiver parameters and synchronizing the scramblers of two connected 100BASE-T2 PHYs or 1000BASE-T. *See: receiver training, blind mode.*

**1.4.308 return loss:** In 10BROAD36, the ratio in decibels of the power reflected from a port to the power incident to the port. An indicator of impedance matching in a broadband system. (See IEEE 802.3, Clause 11.)

**1.4.309  $RIN_x$ OMA:** Relative intensity noise. Laser noise in dB/Hz with x dB optical return loss, with respect to the optical modulation amplitude.

**1.4.310 rising edge:** A rising edge for a differential signal pair, e.g. signal(P,N) is when, signal(P) transitions from logic low to high and signal(N) transitions from logic high to low.

**1.4.311 RMS spectral width:** A measure of the optical wavelength range as defined by ANSI/EIA/TIA 455-127-1991 (FOTP-127) [B10].

**1.4.312 router:** A layer 3 interconnection device that appears as a Media Access Control (MAC) to a CSMA/CD collision domain. (See IEEE Std 610.7-1995 [B44].)

**1.4.313 run length:** The number of consecutive identical bits in a code-group. For example, the pattern 0011111010 has a run length of five. (See IEEE 802.3 Clause 36.)

**1.4.314 run-length-limited code:** Any transmission code that has limited run-length for its transmission. (See IEEE 802.3 Clause 36.)

**1.4.315 running disparity:** A binary parameter having a value of + or –, representing the imbalance between the number of ones and zeros in a sequence of 8B/10B code-groups. (See IEEE 802.3, 36.2.4.3.)

**1.4.316 scrambler:** A randomizing mechanism that is used to eliminate long strings of consecutive identical transmitted symbols and avoid the presence of spectral lines in the signal spectrum without changing the signaling rate. A self-synchronous scrambler is one in which the current state of the scrambler is the prior n bits of the scrambled output. Therefore, the descrambler can acquire the correct state directly from the received stream. A side-stream scrambler is one in which the current state of the scrambler is dependent only on the prior state of the scrambler and not on the transmitted data. Therefore, the descrambler must acquire state either by searching for a state that decodes a known pattern or by agreement to start at a known state in synchronization with the scrambler. A frame-synchronous scrambler is a side-stream scrambler that begins each frame in a known state. This definition is derived from ANSI T1.416-1999 and ANSI T1.105-1995, which take precedence.

**1.4.317 Seed:** In 10BROAD36, the 23 bits residing in the scrambler shift register prior to the transmission of a packet. (See IEEE 802.3, Clause 11.)

**1.4.318 segment:** The medium connection, including connectors, between Medium Dependent Interfaces (MDIs) in a CSMA/CD local area network.

**1.4.319 Segment Delay Value (SDV):** A number associated with a given segment that represents the delay on that segment including repeaters and end stations, if present, used to assess path delays for 10 Mb/s CSMA/CD networks. (See IEEE 802.3, 13.4.)

**1.4.320 Segment Variability Value (SVV):** A number associated with a given segment that represents the delay variability on that segment (including a repeater) for 10 Mb/s CSMA/CD networks. The SVVs for different segment types are specified in IEEE 802.3, Table 13–3. (See IEEE 802.3, 13.4.)

**1.4.321 shared service:** A CSMA/CD network in which the collision domain consists of more than two DTEs so that the total network bandwidth is shared among them.

**1.4.322 shielded twisted-pair (STP) cable:** An electrically conducting cable, comprising one or more elements, each of which is individually shielded. There may be an overall shield, in which case the cable is referred to as shielded twisted-pair cable with an overall shield (from ISO/IEC 11801:1995). Specifically for IEEE 802.3 100BASE-TX, 150  $\Omega$  balanced inside cable with performance characteristics specified to 100 MHz (i.e., performance to Class D link standards as per ISO/IEC 11801:1995). In addition to the requirements specified in ISO/IEC 11801:1995, IEEE Std 802.3, Clause 23 and Clause 25, provide additional performance requirements for 100BASE-T operation over STP.

**1.4.323 simplex fiber optic link segment:** A single fiber path between two Medium Attachment Units (MAUs) or PHYs, including the terminating connectors, consisting of one or more fibers joined serially with appropriate connection devices, for example, patch cables and wall plates. (See IEEE 802.3, Clause 15.)

**1.4.324 simplex link segment:** A path between two Medium Dependent Interfaces (MDIs), including the terminating connectors, consisting of one or more segments of twisted pair cable joined serially with appropriate connection devices, for example, patch cords and wall plates. (See IEEE 802.3, Figure 14–2.)

**1.4.325 single-port device:** A device with a single instance of MDI. (See IEEE 802.3, Clause 40.)

**1.4.326 skew between pairs:** The difference in arrival times of two initially coincident signals propagated over two different pairs, as measured at the receiving end of the cable. Total skew includes contributions from transmitter circuits as well as the cable.

**1.4.327 slave Physical Layer (PHY):** Within IEEE 802.3, in a 100BASE-T2 or 1000BASE-T link containing a pair of PHYs, the PHY that recovers its clock from the received signal and uses it to determine the timing of transmitter operations. It also uses the slave transmit scrambler generator polynomial for side-stream scrambling. Master and slave PHY status is determined during the Auto-Negotiation process that takes place prior to establishing the transmission link. *See also:* **master Physical Layer (PHY).**

**1.4.328 sliver:** A pulse with a duration less than that specified for that signal (e.g., truncated clock signal).

**1.4.329 special link (SL):** A transmission system that replaces the normal medium. (See IEEE 802.3, 12.8.)

**1.4.330 spectral width, full-width half maximum (FWHM):** The absolute difference between the wavelengths at which the spectral radiant intensity is 50% of the maximum. (See IEEE 802.3, Clause 15.)

**1.4.331 spectrum mask:** A graphic representation of the required power distribution as a function of frequency for a modulated transmission.

**1.4.332 star quad:** A cable element that comprises four insulated conductors twisted together. Two diametrically facing conductors form a transmission pair.

NOTE—Cables containing star quads can be used interchangeably with cables consisting of pairs, provided the electrical characteristics meet the same specifications. (From ISO/IEC 11801.)

**1.4.333 Start\_of\_Packet Delimiter (SPD):** In 1000BASE-X, a single code-group 8B/10B ordered\_set used to delineate the starting boundary of a data transmission sequence for a single packet. (See IEEE 802.3, Clause 36.)

**1.4.334 Start-of-Stream Delimiter (SSD):** Within IEEE 802.3, a pattern of defined codewords used to delineate the boundary of a data transmission sequence on the Physical Layer stream. The SSD is unique in that it may be recognized independent of previously defined code-group boundaries and it defines subsequent code-group boundaries for the stream it delimits. For 100BASE-T4, SSD is a pattern of three predefined sosb code-groups (one per wire pair) indicating the positions of the first data code-group on each wire pair. For 100BASE-X, SSD consists of the code-group sequence /J/K/. For 100BASE-T2, the SSD is indicated by two consecutive pairs of predefined PAM5×5 symbols ( $\pm 2$ ,  $\pm 2$ ) ( $\pm 2$ , 0) which are generated using unique SSD/ESD coding rules. For 1000BASE-T, the SSD is indicated by two consecutive vectors of four quinary symbols as specified in Table 40–1.

**1.4.335 stream:** The Physical Layer (PHY) encapsulation of a Media Access Control (MAC) frame. Depending on the particular PHY, the MAC frame may be modified or have information appended or prepended to it to facilitate transfer through the Physical Medium Attachment (PMA). Any conversion from a MAC frame to a PHY stream and back to a MAC frame is transparent to the MAC. (See IEEE 802.3, Clause 23 and Clause 24.)

**1.4.336 switch:** A layer 2 interconnection device that conforms to the ISO/IEC 10038 [ANSI/IEEE 802.1D-1998]. *Syn:* **bridge.**

**1.4.337 symbol:** Within IEEE 802.3, the smallest unit of data transmission on the medium. Symbols are unique to the coding system employed. 100BASE-T4 uses ternary symbols; 10BASE-T uses Manchester symbols; 100BASE-X uses binary symbols or code bits; 100BASE-T2 and 1000BASE-T uses quinary symbols.

**1.4.338 symbol period:** In 1000BASE-T, the time interval for transmission of one code-group. This is equivalent to eight nanoseconds. (See IEEE 802.3, Clause 40.)

**1.4.339 symbol rate (SR):** Within IEEE 802.3, the total number of symbols per second transferred to or from the Medium Dependent Interface (MDI) on a single wire pair. For 100BASE-T4, the symbol rate is 25 MBd; for 100BASE-X, the symbol rate is 125 MBd; for 100BASE-T2, the symbol rate is 25 MBd; for 1000BASE-T, the symbol rate is 125 MBd.

**1.4.340 symbol time (ST):** The duration of one symbol as transferred to and from the Medium Dependent Interface (MDI) via a single wire pair. The symbol time is the reciprocal of the symbol rate.

**1.4.341 Synchronous Payload Envelope (SPE):** A 125-microsecond frame structure composed of STS Path Overhead and bandwidth for payload (payload capacity). The equivalent SDH term is Virtual Container (VC). This definition is derived from ANSI T1.416-1999 and ANSI T1.105-1995, which take precedence.

**1.4.342 ternary symbol:** In 100BASE-T4, a ternary data element. A ternary symbol can have one of three values:  $-1$ , 0, or  $+1$ . (See IEEE 802.3, Clause 23.)

**1.4.343 Tomlinson-Harashima precoder (THP):** A precoding technique for intersymbol interference mitigation. (See IEEE 802.3, Clause 55.)

**1.4.344 transition density:** The number of times the stream of bits within an 8B/10B code-group changes its value. (See IEEE 802.3, Clause 36.)

**1.4.345 translation:** In a single-cable 10BROAD36 system, the process by which incoming transmissions at one frequency are converted into another frequency for outgoing transmission. The translation takes place at the headend. (See IEEE 802.3, Clause 11.)

**1.4.346 transmitter and dispersion penalty:** A measure of the performance of a transmitter relative to an ideal transmitter. (See IEEE 802.3, 52.9.10 and 58.7.9.)

**1.4.347 truncation loss:** In a modulated data waveform, the power difference before and after implementation filtering necessary to constrain its spectrum to a specified frequency band.

**1.4.348 trunk cable:** The main (often large diameter) cable of a coaxial cable system. (*See: drop cable.*)

**1.4.349 twinaxial cable:** A cable similar to coaxial cable in construction but containing two insulated inner conductors rather than one.

**1.4.350 twinaxial cable assembly:** An assembly containing multiple twinaxial cables, terminated in a connector at each end, for use as a link segment between MDIs, such as that used in 10GBASE-CX4.

**1.4.351 twisted pair:** A cable element that consists of two insulated conductors twisted together in a regular fashion to form a balanced transmission line. (From ISO/IEC 11801:1995.)

**1.4.352 twisted-pair cable:** A bundle of multiple twisted pairs within a single protective sheath. (From ISO/IEC 11801:1995.)

**1.4.353 twisted-pair cable binder group:** A group of twisted pairs within a cable that are bound together. Large telephone cables have multiple binder groups with high interbinder group near-end crosstalk loss.

**1.4.354 twisted-pair link:** A twisted-pair cable plus connecting hardware. (From ISO/IEC 11801:1995.) (See also IEEE 802.3, 14.1.2.)

**1.4.355 twisted-pair link segment:** In 100BASE-T, a twisted-pair link for connecting two Physical Layers (PHYs). (See also IEEE 802.3, 14.1.2.)

**1.4.356 Twisted Pair Medium Dependent Interface (TP MDI):** The mechanical and electrical interface between the transmission medium and the Medium Attachment Unit (MAU) or PHY, e.g., 10BASE-T, 100BASE-TX, or 1000BASE-T.

**1.4.357 Type:** A 2 octet value that indicates the nature of the MAC client protocol. Type values are assigned by the IEEE Registration Authority. (See: IEEE 802.3, 3.2.6.)

**1.4.358 type, length, value (TLV):** A short, variable length encoding of an information element consisting of sequential type, length, and value fields where the type field identifies the type of information, the length field indicates the length of the information field in octets, and the value field contains the information, itself (See IEEE 802.3, 57.5.2 and 57.5.3).

**1.4.359 uncorrelated jitter:** Jitter that is not associated with the sequence being transmitted. (See IEEE 802.3, 68.6.8.)

**1.4.360 Unformatted Page (UP):** A next page encoding that contains an unformatted 12-bit message field. Use of this field is defined through message codes and information contained in the UP. (See IEEE 802.3, 28.2.1.2.)

**1.4.361 unit interval (UI):** A period of time, usually allocated for the transmission of one symbol on one channel; the inverse of the modulation rate. Generally not the same as bit time (BT).

**1.4.362 unshielded twisted-pair cable (UTP):** An electrically conducting cable, comprising one or more pairs, none of which is shielded. There may be an overall shield, in which case the cable is referred to as unshielded twisted-pair with overall shield. (From ISO/IEC 11801:1995.)

**1.4.363 upstream:** In an access network, transmission away from the subscriber end of the link. Applicable to networks where there is a clear indication in each deployment as to which end of a link is closer to a subscriber.

**1.4.364 WAN Interface Sublayer (WIS):** Within 10GBASE-W, a sublayer used to couple the Physical Coding Sublayer (PCS) and the Physical Medium Attachment (PMA) sublayer. The WIS contains functions to perform SONET STS-192c/SDH VC-4-64c framing and scrambling. (See IEEE 802.3, Clause 50.)

**1.4.365 weight of 6T code group:** The algebraic sum of the logical ternary symbol values listed in the 100BASE-T4 8B6T code table. (See IEEE 802.3, Clause 23.)

**1.4.366 worst-case modal bandwidth (WCMB):** The lowest value of the modal bandwidth found when measured using either an overfilled launch (OFL) or a radial overfilled launch (ROFL).

**1.4.367 zero dispersion wavelength:** That wavelength where the chromatic dispersion of a fiber is zero.

## 1.5 Abbreviations

This standard contains the following abbreviations:

10P	label to indicate “pertains to 10PASS-TS port-type”
10P/2B	label to indicate “pertains to 10PASS-TS and 2BASE-TL port-types”
2B	label to indicate “pertains to 2BASE-TL port-type”
2-PAM	two level pulse amplitude modulation
8802-3	ISO/IEC 8802-3 (IEEE Std 802.3)
8802-5	ISO/IEC 8802-5 (IEEE Std 802.5)
AIS	Alarm Indication Signal
AN	Auto-Negotiation
ANSI	American National Standards Institute
ASIC	application-specific integrated circuit
ASN.1	Abstract Syntax Notation One as defined in ISO/IEC 8824:1990
AUI	attachment unit interface
BER	bit error ratio
BERT	bit error ratio tester
BIP	Bit Interleaved Parity
BP	backplane
BPSK	binary phase shift keying
BR	bit rate
BT	bit time
CAT3	Category 3 balanced cable
CAT4	Category 4 balanced cable
CAT5	Category 5 balanced cable
CAT6	Category 6 balanced cabling
CD0	clocked data zero
CD1	clocked data one
CDR	clock and data recovery
CID	Consecutive Identical Digit
CJPAT	continuous jitter test pattern
CMIP	common management information protocol as defined in ISO/IEC 9596-1:1991

CMIS	common management information service as defined in ISO/IEC 9595:1991
CMOS	complementary metal oxide semiconductor
CO	central office
CPE	customer premises equipment
CPR	coupled power ratio
CRC	cyclic redundancy check
CRPAT	continuous random test pattern
CRU	clock recovery unit
CRV	code rule violation
CS0	control signal zero
CS1	control signal one
CVH	clocked violation high
CVL	clocked violation low
CW	continuous wave
DA	destination address
DCD	duty cycle distortion
DDJ	data dependent jitter
DFE	decision feedback equalizer
DJ	deterministic jitter
DME	Differential Manchester encoding
DMT	discrete multi-tone
DSL	digital subscriber line
DSQ	double square
DTE	data terminal equipment
EFM	Ethernet in the first mile
EIA	Electronic Industries Association
ELFEXT	equal-level far-end crosstalk
EMI	electromagnetic interference
EPD	End_of_Packet delimiter
ERDI	Enhanced Remote Defect Indication
ESD	end of stream delimiter
FC-PH	Fibre Channel—Physical and Signaling Interface
FCS	frame check sequence
FDDI	fibre distributed data interface
FEC	forward error correction
FEXT	far-end crosstalk
FIFO	first in, first out
FIR	finite impulse response
FLP	fast link pulse
FOIRL	fiber optic inter-repeater link
FOMAU	fiber optic medium attachment unit
FOMDI	fiber optic medium dependent interface
FOPMA	fiber optic physical medium attachment
FOTP	fiber optic test procedure
FSW	frame synchronization word
GMII	Gigabit Media Independent Interface
HH	header hub
IB	indicator bits
IEC	International Electrotechnical Commission
IH	intermediate hub
IPG	inter-packet gap
IRL	inter-repeater link
ISI penalty	intersymbol interference penalty
ISO	International Organization for Standardization

LACP	Link Aggregation Control Protocol
LACPDU	Link Aggregation Control Protocol Data Unit
LAG	Link Aggregation Group
LAG ID	Link Aggregation Group Identifier
LAN	local area network
LCD	Loss Of Code-Group Delineation
LD	local device
LDPC	low density parity check
LLC	logical link control
LLID	logical link identifier
LOF	Loss Of Framing
LOP	Loss Of Pointer
LOS	Loss Of Signal
LP	link partner
LSDV	link segment delay value
LT	line termination
LVDS	Low-Voltage Differential Signals
MAC	medium access control
MAN	Metropolitan Area Network
MAU	medium attachment unit
MC	message code
MDELNEXT	multiple-disturber equal-level far-end crosstalk
MDFEXT	multiple-disturber far-end crosstalk
MDI	medium dependent interface
MDIO	management data input/output
MDNEXT	multiple-disturber near-end crosstalk
MIB	management information base
MII	media independent interface
MMD	MDIO Manageable Device
MMF	multimode fiber
MP	message page
MPCP	multipoint control protocol
MPS	Maintain Power Signature
Mux	multiplexer
NEXT	Near-end Crosstalk
NID	network interface device
NLP	normal link pulse
NP	next page
NPA	next page algorithm
NRZI	non return to zero and invert on ones
NT	network termination
NTT	Need To Transmit
OAM	operations, administration, and maintenance
OAMPDU	operations, administration, and maintenance protocol data unit
ODN	optical distribution network
OFL	overfilled launch
OFSTP	optical fiber system test procedure
OH	overhead
OIF	Optical Internetworking Forum
OLT	optical line terminal
OMA	Optical Modulation Amplitude
ONU	optical network unit
ORLT	optical return loss tolerance
P2MP	point to multipoint

P2P	point to point
P2PE	point-to-point emulation
PAF	PME aggregation function
PAM	pulse amplitude modulation
PCB	printed circuit board
PCS	physical coding sublayer
PD	Powered Device
PDU	Protocol Data Unit
PDV	path delay value
PHY	Physical Layer entity
PI	Power Interface
PICS	protocol implementation conformance statement
PIPO	parallel in parallel out
PISO	parallel in serial out
pk-pk	peak-to-peak
PLL	phase locked loop
PLM	Path Label Mismatch
PLS	physical signaling sublayer
PMA	physical medium attachment
PMD	physical medium dependent
PME	physical medium entity
PMI	physical medium independent
PMS-TC	physical media specific - transmission convergence
ppd	peak-to-peak differential
PRBS	pseudo random bit sequence
PSD	power spectral density
PSE	Power Sourcing Equipment
PVV	path variability value
RD	running disparity
REI	Remote Error Indication
RFI	radio frequency interference
RIN	relative intensity noise
RJ	random jitter
ROFL	radial overfilled launch
RS	reconciliation sublayer
SA	source address
SCB	single copy broadcast
SDH	Synchronous Digital Hierarchy
SDV	segment delay value
SEF	Severely Errored Frame
SELV	Safety Extra Low Voltage
SERDES	serializer and deserializer circuit
SES	Severely Errored Second
SFD	start-of-frame delimiter
SFDR	spurious free dynamic range
SHDSL	single-pair high-speed digital subscriber line
SIPO	serial in parallel out
SMF	single-mode fiber
SMSR	side mode suppression ratio
SNR	signal-to-noise ratio
SONET	Synchronous Optical Network
SPD	Start_of_Packet delimiter
SPE	Synchronous Payload Envelope
SR	symbol rate



SSD	start-of-stream delimiter
ST	symbol time
STA	station management entity
STP	shielded twisted pair (copper)
STS	Synchronous Transport Signal
SVV	segment variability value
TBI	Ten-Bit Interface
TC	transmission convergence
TCM	trellis coded modulation
TDP	transmitter and dispersion penalty
TDR	time domain reflectometer
THP	Tomlinson-Harashima precoder
TIA	Telecommunications Industry Association
TLV	Type/Length/Value
TPS-TC	transport protocol specific transmission convergence sublayer
TSS	Test Signal Structure
TWDP	transmitter waveform and dispersion penalty
UCT	unconditional transition
UI	unit interval
UJ	uncorrelated jitter
UP	unformatted page
UPBO	upstream power backoff
UTP	unshielded twisted pair
VC	Virtual Container
VDSL	very high speed digital subscriber line
VECP	vertical eye closure penalty
VLAN	Virtual Bridged Local Area Network (see IEEE Std 802.1Q)
VTU	VDSL transceiver unit
VTU-O	VTU at the central office end
VTU-R	VTU at the remote end
WAN	Wide Area Network
WCMB	worst-case modal bandwidth
WIS	WAN Interface Sublayer
WWDM	wide wavelength division multiplexing
XAUI	10 Gigabit Attachment Unit Interface
xDSL	generic term covering the family of all DSL technologies
XGMII	10 Gigabit Media Independent Interface
XGXS	XGMII Extender Sublayer
XNP	extended Next Page
XS	Extender Sublayer
XSBI	10 Gigabit Sixteen-Bit Interface



## 2. Media Access Control (MAC) service specification

### 2.1 Scope and field of application

This clause specifies the services provided by the Media Access Control (MAC) sublayer to the client of the MAC (see Figure 1–1). MAC clients may include the Logical Link Control (LLC) sublayer, Bridge Relay Entity, or other users of ISO/IEC LAN International Standard MAC services (see Figure 2–1). The services are described in an abstract way and do not imply any particular implementation or any exposed interface. Other clauses in this standard may add optional protocol sublayers directly above the MAC that preserve the service interface to the MAC client. Any augmentations to the MAC client interface are specified in the relevant sublayer clause (e.g., Clause 31).

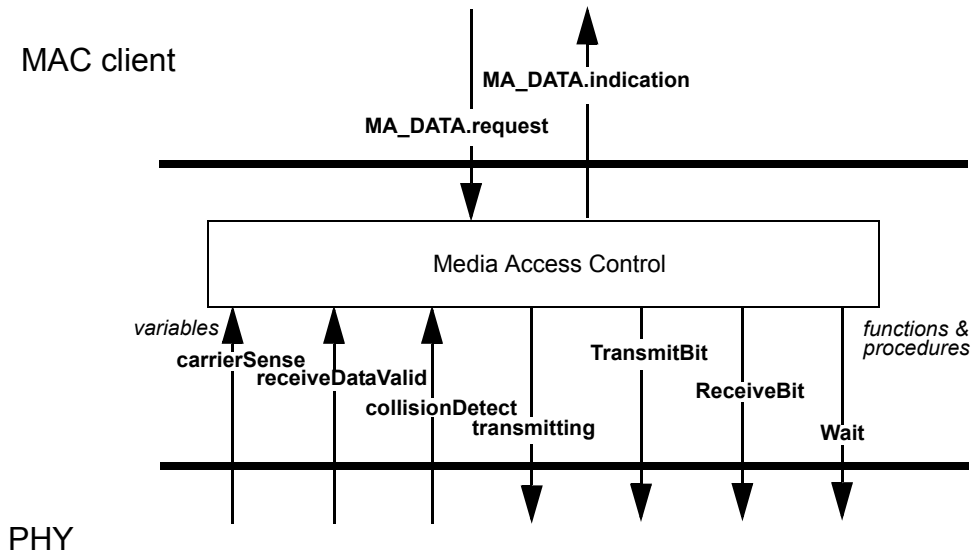


Figure 2–1—Service specification primitive relationships

### 2.2 Overview of the service

#### 2.2.1 General description of services provided by the layer

The services provided by the MAC sublayer allow the local MAC client entity to exchange LLC data units with peer LLC sublayer entities. Optional support may be provided for resetting the MAC sublayer entity to a known state.

#### 2.2.2 Model used for the service specification

The model used in this service specification is identical to that used in 1.2.2.

#### 2.2.3 Overview of interactions

MA\_DATA.request  
MA\_DATA.indication

## 2.2.4 Basic services

The MA\_DATA.request and MA\_DATA.indication service primitives described in this subclause are mandatory.

## 2.3 Detailed service specification

### 2.3.1 MA\_DATA.request

#### 2.3.1.1 Function

This primitive defines the transfer of data from a MAC client entity to a single peer entity or multiple peer entities in the case of group addresses.

#### 2.3.1.2 Semantics of the service primitive

The semantics of the primitive are as follows:

```
MA_DATA.request      (
                      destination_address,
                      source_address,
                      mac_service_data_unit,
                      frame_check_sequence
                      )
```

The destination\_address parameter may specify either an individual or a group MAC entity address. It must contain sufficient information to create the DA field that is prepended to the frame by the local MAC sublayer entity and any physical information. The source\_address parameter, if present, must specify an individual MAC address. If the source\_address parameter is omitted, the local MAC sublayer entity will insert a value associated with that entity. The mac\_service\_data\_unit parameter specifies the MAC service data unit to be transmitted by the MAC sublayer entity. There is sufficient information associated with the mac\_service\_data\_unit for the MAC sublayer entity to determine the length of the data unit. The frame\_check\_sequence parameter, if present, must specify the frame check sequence field for the frame (see 3.2.8). If the frame\_check\_sequence parameter is omitted, the local MAC sublayer entity will compute this field and append it to the end of the frame.

#### 2.3.1.3 When generated

This primitive is generated by the MAC client entity whenever data shall be transferred to a peer entity or entities. This can be in response to a request from higher protocol layers or from data generated internally to the MAC client, such as required by Type 2 LLC service.

#### 2.3.1.4 Effect of receipt

The receipt of this primitive will cause the MAC entity to insert all MAC specific fields, including DA, SA, and any fields that are unique to the particular media access method, and pass the properly formed frame to the lower protocol layers for transfer to the peer MAC sublayer entity or entities.

#### 2.3.1.5 Additional comments

If this primitive contains the frame\_check\_sequence parameter, the MAC client entity must take into account this parameter's special bit-transmission order requirements, as specified in 3.3.

The mapping between the MA\_UNITDATA.request primitive specified in ISO/IEC 15802-1 (for end stations) and the MA\_DATA.request primitive specified here is as follows:

- a) The user\_priority parameter specified for MA\_UNITDATA.request is not relevant for IEEE 802.3 operation and is ignored by MA\_DATA.request.
- b) The access\_priority parameter specified for MA\_UNITDATA.request is not relevant for IEEE 802.3 operation and is ignored by MA\_DATA.request.
- c) The frame\_check\_sequence parameter is not present for MA\_UNITDATA.request.

The mapping between the M\_UNITDATA.request primitive specified in IEEE Std 802.1D (for MAC Bridges) and the MA\_DATA.request primitive specified here is as follows:

- d) The frame\_type parameter specified for M\_UNITDATA.request is not relevant for IEEE 802.3 operation and is ignored by MA\_DATA.request.
- e) The mac\_action parameter specified for M\_UNITDATA.request is not relevant for IEEE 802.3 operation and is ignored by MA\_DATA.request.
- f) The user\_priority parameter specified for M\_UNITDATA.request is not relevant for IEEE 802.3 operation and is ignored by MA\_DATA.request.
- g) The access\_priority parameter specified for M\_UNITDATA.request is not relevant for IEEE 802.3 operation and is ignored by MA\_DATA.request.

## 2.3.2 MA\_DATA.indication

### 2.3.2.1 Function

This primitive defines the transfer of data from the MAC sublayer entity (through the optional MAC Control sublayer, if implemented) to the MAC client entity or entities in the case of group addresses.

### 2.3.2.2 Semantics of the service primitive

The semantics of the primitive are as follows:

```
MA_DATA.indication      (
                        destination_address,
                        source_address,
                        mac_service_data_unit,
                        frame_check_sequence,
                        reception_status
                        )
```

The destination\_address parameter may be either an individual or a group address as specified by the DA field of the incoming frame. The source\_address parameter is an individual address as specified by the SA field of the incoming frame. The mac\_service\_data\_unit parameter specifies the MAC service data unit as received by the local MAC entity. The frame\_check\_sequence parameter is the cyclic redundancy check value (see 3.2.9) as specified by the FCS field of the incoming frame. This parameter may be either omitted or (optionally) passed by the MAC sublayer entity to the MAC client. The reception\_status parameter is used to pass status information to the MAC client entity.

### 2.3.2.3 When generated

The MA\_DATA.indication is passed from the MAC sublayer entity (through the optional MAC Control sublayer, if implemented) to the MAC client entity or entities to indicate the arrival of a frame to the local MAC sublayer entity that is destined for the MAC client. Such frames are reported only if they are validly formed,

received without error, and their destination address designates the local MAC entity. Frames destined for the optional MAC Control sublayer are not passed to the MAC client if the MAC Control sublayer is implemented.

#### **2.3.2.4 Effect of receipt**

The effect of receipt of this primitive by the MAC client is unspecified.

#### **2.3.2.5 Additional comments**

If the local MAC sublayer entity is designated by the `destination_address` parameter of an `MA_DATA.request`, the indication primitive will also be invoked by the MAC entity to the MAC client entity. This characteristic of the MAC sublayer may be due to unique functionality within the MAC sublayer or characteristics of the lower layers (for example, all frames transmitted to the broadcast address will invoke `MA_DATA.indication` at all stations in the network including the station that generated the request).

If this primitive contains the `frame_check_sequence` parameter, the MAC client entity must take into account this parameter's special bit-transmission order requirements, as specified in 3.3.

The mapping between the `MA_DATA.indication` primitive specified here and the `MA_UNITDATA.indication` primitive specified in ISO/IEC 15802-1 (for end stations) is as follows:

- a) The `user_priority` parameter specified for `MA_UNITDATA.indication` is not relevant for IEEE 802.3 operation.
- b) The `frame_check_sequence` parameter is not present for `MA_UNITDATA.indication`.
- c) The `reception_status` parameter is not mapped to any parameter and is ignored by `MA_UNITDATA.indication`.

The mapping between the `MA_DATA.indication` primitive and the `M_UNITDATA.indication` primitive specified in IEEE Std 802.1D (for MAC Bridges) is as follows:

- a) The `frame_type` parameter specified for `M_UNITDATA.indication` is not relevant for IEEE 802.3 operation and is always assigned the value of `user_data_frame`.
- b) The `mac_action` parameter specified for `M_UNITDATA.indication` is not relevant for IEEE 802.3 operation and is always assigned the value of `request_with_no_response`.
- c) The `user_priority` parameter specified for `M_UNITDATA.indication` is not relevant for IEEE 802.3 operation.
- d) The `reception_status` parameter is not mapped to any parameter and is ignored by `M_UNITDATA.indication`.

### 3. Media Access Control (MAC) frame and packet specifications

#### 3.1 Overview

This clause defines the mapping between MAC service interface primitives and Ethernet packets, including the syntax and semantics of the various fields of MAC frames and the fields used to form those MAC frames into packets.

During Ethernet's history, capabilities have been added to allow data link layer (layer 2) protocol encapsulations within the MAC Client Data field. As a result, there are now more than one type of MAC frame.

The frame format specified in this clause includes the following three types of MAC frames:

- a) A basic frame
- b) A Q-tagged frame
- c) An envelope frame

All three frame types use the same Ethernet frame format.

#### 3.1.1 Packet format

Figure 3–1 shows the fields of a packet: the Preamble, Start Frame Delimiter (SFD), the addresses of the MAC frame's destination and source, a length or type field to indicate the length or protocol type of the following field that contains the MAC client data, a field that contains padding if required, and the Frame Check Sequence (FCS) field containing a cyclic redundancy check value to detect errors in a received MAC frame. An Extension field is added, if required (for 1000 Mb/s half duplex operation only). Of these fields, all are of fixed size except for the MAC Client Data, Pad and Extension fields, which may contain an integer number of octets between the minimum and maximum values that are determined by the specific implementation of the MAC. See 4.4 for particular MAC parameters.

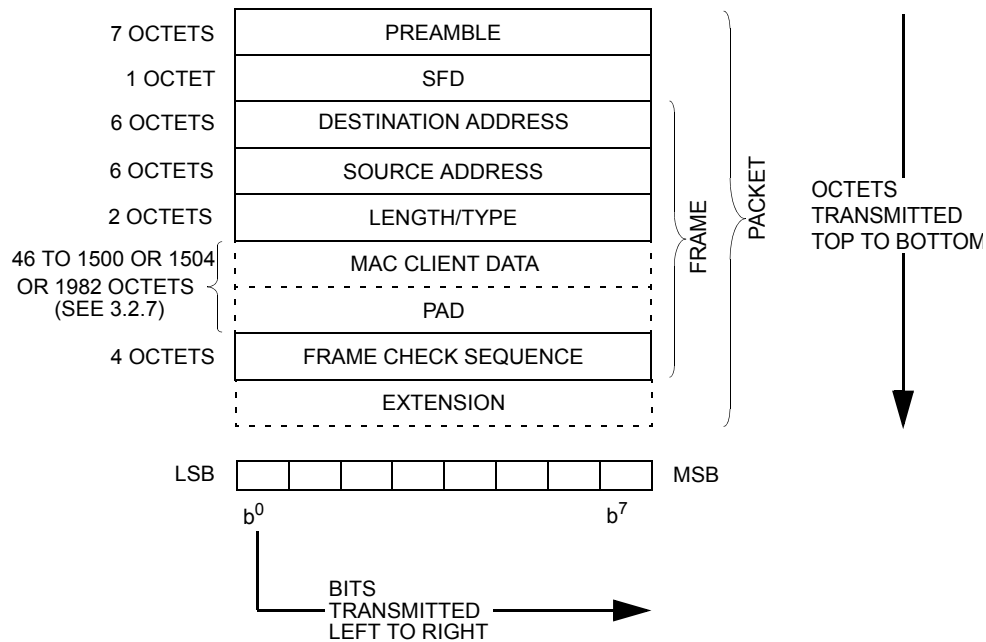


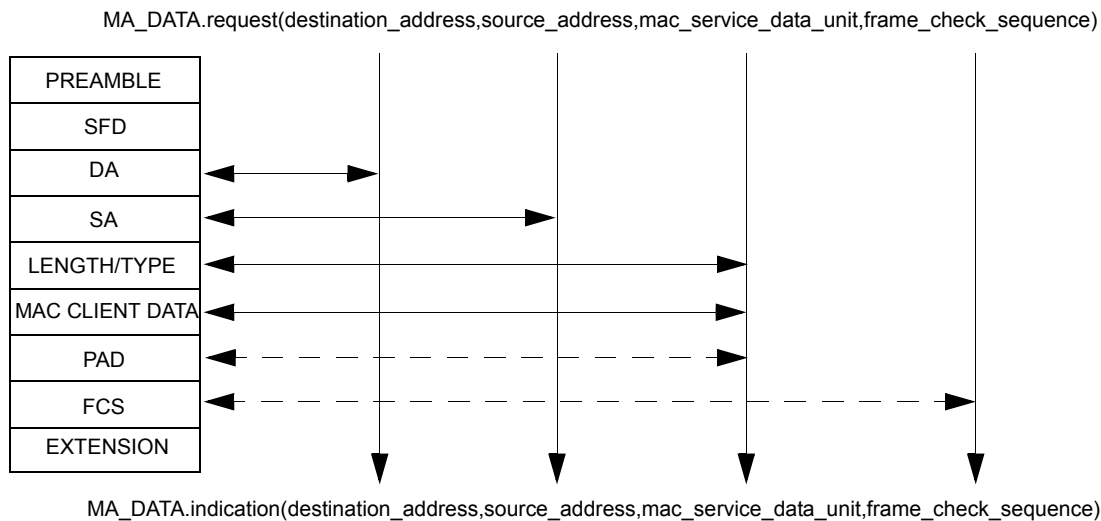
Figure 3–1—Packet format

The minimum and maximum MAC frame size limits in 4.4 refer to that portion of the packet from the dEsti-  
nation Address field through the Frame Check Sequence field, inclusive (i.e., the MAC frame).

Relative to Figure 3–1, the octets of a packet are transmitted from top to bottom, and the bits of each octet  
are transmitted from left to right.

### 3.1.2 Service interface mappings

Figure 3–2 shows the mapping of service interface parameters to the fields of a MAC frame within a packet.  
The MAC client may or may not supply Pad and FCS. For this reason the mappings for Pad and FCS are  
shown with dashed lines.



**Figure 3–2—Service primitive mappings**

## 3.2 Elements of the MAC frame and packet

A MAC frame is encapsulated in a packet by the MAC. This subclause describes in detail the fields of the  
MAC frame and the additional fields that the MAC creates to encapsulate the MAC frame. These fields are  
described in order of transmission.

### 3.2.1 Preamble field

The Preamble field is a 7-octet field that is used to allow the PLS circuitry to reach its steady-state synchro-  
nization with the received packet’s timing (see 4.2.5).

### 3.2.2 Start Frame Delimiter (SFD) field

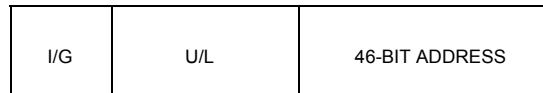
The SFD field is the sequence 10101011. It immediately follows the preamble pattern. A MAC frame starts  
immediately after the SFD.

### 3.2.3 Address fields

Each MAC frame shall contain two address fields: the Destination Address field and the Source Address  
field, in that order. The Destination Address field shall specify the destination addressee(s) for which the  
MAC frame is intended. The Source Address field shall identify the station from which the MAC frame was  
initiated. The representation of each address field shall be as follows (see Figure 3–3):



- a) Each address field shall be 48 bits in length.
- b) The first bit (LSB) shall be used in the Destination Address field as an address type designation bit to identify the Destination Address either as an individual or as a group address. If this bit is 0, it shall indicate that the address field contains an individual address. If this bit is 1, it shall indicate that the address field contains a group address that identifies none, one or more, or all of the stations connected to the LAN. In the Source Address field, the first bit is reserved and set to 0.
- c) The second bit shall be used to distinguish between locally or globally administered addresses. For globally administered (or U, universal) addresses, the bit is set to 0. If an address is to be assigned locally, this bit shall be set to 1. Note that for the broadcast address, this bit is also a 1.
- d) Each octet of each address field shall be transmitted least significant bit first.



I/G = 0 INDIVIDUAL ADDRESS  
 I/G = 1 GROUP ADDRESS  
 U/L = 0 GLOBALLY ADMINISTERED ADDRESS  
 U/L = 1 LOCALLY ADMINISTERED ADDRESS

**Figure 3–3—Address field format**

### 3.2.3.1 Address designation

A MAC sublayer address is one of two types:

- a) *Individual Address*. The address associated with a particular station on the network.
- b) *Group Address*. A multidestination address, associated with one or more stations on a given network. There are two kinds of multicast addresses:
  - 1) *Multicast-Group Address*. An address associated by higher-level convention with a group of logically related stations.
  - 2) *Broadcast Address*. A distinguished, predefined multicast address that always denotes the set of all stations on a given LAN.

All 1's in the Destination Address field shall be predefined to be the Broadcast Address. This group shall be predefined for each communication medium to consist of all stations actively connected to that medium; it shall be used to broadcast to all the active stations on that medium. All stations shall be able to recognize the Broadcast Address. It is not necessary that a station be capable of generating the Broadcast Address.

The address space shall also be partitioned into locally administered and globally administered addresses. The nature of a body and the procedures by which it administers these global (U) addresses is beyond the scope of this standard.<sup>18</sup>

### 3.2.4 Destination Address field

The Destination Address field specifies the station(s) for which the MAC frame is intended. It may be an individual or multicast (including broadcast) address.

<sup>18</sup>For information on how to use MAC addresses, see IEEE Std 802-2001, Overview and Architecture. To apply for an Organizationally Unique Identifier for building a MAC address, contact the Registration Authority, IEEE Standards Department, P.O. Box 1331, 445 Hoes Lane, Piscataway, NJ 08855-1331, USA; +1 732 562 3813; fax +1 732 562 1571. URL: <http://standards.ieee.org/>.

### 3.2.5 Source Address field

The Source Address field specifies the station sending the MAC frame. The Source Address field is not interpreted by the MAC sublayer.

### 3.2.6 Length/Type field

This two-octet field takes one of two meanings, depending on its numeric value. For numerical evaluation, the first octet is the most significant octet of this field.

- a) If the value of this field is less than or equal to 1500 decimal (05DC hexadecimal), then the Length/Type field indicates the number of MAC client data octets contained in the subsequent MAC Client Data field of the basic frame (Length interpretation).
- b) If the value of this field is greater than or equal to 1536 decimal (0600 hexadecimal), then the Length/Type field indicates the nature of the MAC client protocol (Type interpretation).<sup>19</sup>  
The Length and Type interpretations of this field are mutually exclusive.

When used as a Type field, it is the responsibility of the MAC client to ensure that the MAC client operates properly when the MAC sublayer pads the supplied MAC Client data, as discussed in 3.2.7.

Regardless of the interpretation of the Length/Type field, if the length of the MAC Client Data field is less than the minimum required for proper operation of the protocol, a Pad field (a sequence of octets) will be added after the MAC Client Data field but prior to the FCS field, specified below. The procedure that determines the size of the Pad field is specified in 4.2.8. The Length/Type field is transmitted and received with the high order octet first.

NOTE—Clause 2 of IEEE Std 802a-2003 (an amendment to IEEE Std 802) defines a set of Type values and associated mechanisms for use in prototype and vendor-specific protocol development.

### 3.2.7 MAC Client Data field

The MAC Client Data field contains a sequence of octets. Full data transparency is provided in the sense that any arbitrary sequence of octet values may appear in the MAC Client Data field up to a maximum field length determined by the particular implementation.

Ethernet implementations shall support at least one of three maximum MAC Client Data field sizes defined as follows:

- a) 1500 decimal—basic frames (see 1.4.73)
- b) 1504 decimal—Q-tagged frames (see 1.4.291)
- c) 1982 decimal—envelope frames (see 1.4.151)

If layer management is implemented, frames with a MAC Client Data field larger than the supported maximum MAC Client Data field size are counted. It is recommended that new implementations support the transmission and reception of envelope frames, item c) above.

NOTE 1—The envelope frame is intended to allow inclusion of additional prefixes and suffixes required by higher layer encapsulation protocols (see 1.4.x) such as those defined by the IEEE 802.1 working group (such as Provider Bridges and MAC Security), ITU-T or IETF (such as MPLS). The original MAC Client Data field maximum remains 1500 octets while the encapsulation protocols may add up to an additional 482 octets. Use of these extra octets for other purposes is not recommended, and may result in MAC frames being dropped or corrupted as they may violate maximum MAC frame size restrictions if encapsulation protocols are required to operate on them.

<sup>19</sup>Type field assignments are administered by the Registration Authority, IEEE Standards Department, P.O. Box 1331, 445 Hoes Lane, Piscataway, NJ 08855-1331, USA; +1 732 562 3813; fax +1 732 562 1571. URL: <http://standards.ieee.org/>.

NOTE 2—All IEEE 802.3 MAC frames share a common format. The processing of the three types of MAC frames is not differentiated within the IEEE 802.3 MAC, except for management. However, they may be distinguished within the MAC client.

NOTE 3—All Q-tagged frames are envelope frames, but not all envelope frames are Q-tagged frames.

See 4.4 for a discussion of MAC parameters; see 4.2.3.3 for a discussion of the minimum frame size and minFrameSize.

### 3.2.8 Pad field

A minimum MAC frame size is required for correct CSMA/CD protocol operation (see 4.2.3.3 and 4.4). If necessary, a Pad field (in units of octets) is appended after the MAC Client Data field prior to calculating and appending the FCS field. The size of the Pad, if any, is determined by the size of the MAC Client Data field supplied by the MAC client and the minimum MAC frame size and address size MAC parameters (see 4.4).

The length of the Pad field required for MAC Client Data that is clientDatasize/8 octets long is  $\max [0, \text{minFrameSize} - (\text{clientDatasize} + 2 \times \text{addressSize} + 48)]$  bits.

### 3.2.9 Frame Check Sequence (FCS) field

A cyclic redundancy check (CRC) is used by the transmit and receive algorithms to generate a CRC value for the FCS field. The FCS field contains a 4-octet (32-bit) CRC value. This value is computed as a function of the contents of the protected fields of the MAC frame: the Destination Address, Source Address, Length/Type field, MAC Client Data, and Pad (that is, all fields except FCS). The encoding is defined by the following generating polynomial.

$$G(x) = x^{32} + x^{26} + x^{23} + x^{22} + x^{16} + x^{12} + x^{11} + x^{10} + x^8 + x^7 + x^5 + x^4 + x^2 + x + 1$$

Mathematically, the CRC value corresponding to a given MAC frame is defined by the following procedure:

- a) The first 32 bits of the frame are complemented.
- b) The  $n$  bits of the protected fields are then considered to be the coefficients of a polynomial  $M(x)$  of degree  $n - 1$ . (The first bit of the Destination Address field corresponds to the  $x^{(n-1)}$  term and the last bit of the MAC Client Data field (or Pad field if present) corresponds to the  $x^0$  term.)
- c)  $M(x)$  is multiplied by  $x^{32}$  and divided by  $G(x)$ , producing a remainder  $R(x)$  of degree  $\leq 31$ .
- d) The coefficients of  $R(x)$  are considered to be a 32-bit sequence.
- e) The bit sequence is complemented and the result is the CRC.

The 32 bits of the CRC value are placed in the FCS field so that the  $x^{31}$  term is the left-most bit of the first octet, and the  $x^0$  term is the right most bit of the last octet. (The bits of the CRC are thus transmitted in the order  $x^{31}, x^{30}, \dots, x^1, x^0$ .) See Hammond, et al. [B37].

### 3.2.10 Extension field

The Extension field follows the FCS field, and is made up of a sequence of extension bits, which are readily distinguished from data bits. The length of the field is in the range of zero to  $(\text{slotTime} - \text{minFrameSize})$  bits, inclusive. The contents of the Extension field are not included in the FCS computation.

The Extension field may have a length of greater than zero under the conditions that are described in 4.2.3.4. The length of the Extension field will be zero under all other conditions. Implementations defined in 4.4.2 may ignore this field altogether if the number of bit times in the slotTime parameter is equal to the number of bits in the minFrameSize parameter.

### 3.3 Order of bit transmission

Each octet of the MAC frame, with the exception of the FCS, is transmitted least significant bit first.

### 3.4 Invalid MAC frame

An invalid MAC frame shall be defined as one that meets at least one of the following conditions:

- a) The frame length is inconsistent with a length value specified in the length/type field. If the length/type field contains a type value as defined by 3.2.6, then the frame length is assumed to be consistent with this field and should not be considered an invalid frame on this basis.
- b) It is not an integral number of octets in length.
- c) The bits of the incoming frame (exclusive of the FCS field itself) do not generate a CRC value identical to the one received.

The contents of invalid MAC frames shall not be passed to the LLC or MAC Control sublayers.<sup>20</sup> The occurrence of invalid MAC frames may be communicated to network management.

---

<sup>20</sup>Invalid MAC frames may be ignored, discarded, or used in a private manner by MAC clients other than LLC or MAC control. The use of such frames is beyond the scope of this standard.

## 4. Media Access Control

### 4.1 Functional model of the MAC method

#### 4.1.1 Overview

The architectural model described in Clause 1 is used in this clause to provide a functional description of the LAN CSMA/CD MAC sublayer.

The MAC sublayer defines a medium-independent facility, built on the medium-dependent physical facility provided by the Physical Layer, and under the access-layer-independent LAN LLC sublayer (or other MAC client). It is applicable to a general class of local area broadcast media suitable for use with the media access discipline known as Carrier Sense Multiple Access with Collision Detection (CSMA/CD).

The LLC sublayer and the MAC sublayer together are intended to have the same function as that described in the OSI model for the Data Link Layer alone. In a broadcast network, the notion of a data link between two network entities does not correspond directly to a distinct physical connection. Nevertheless, the partitioning of functions presented in this standard requires two main functions generally associated with a data link control procedure to be performed in the MAC sublayer. They are as follows:

- a) Data encapsulation (transmit and receive)
  - 1) Framing (frame boundary delimitation, frame synchronization)
  - 2) Addressing (handling of source and destination addresses)
  - 3) Error detection (detection of physical medium transmission errors)
- b) Media Access Management
  - 1) Medium allocation (collision avoidance)
  - 2) Contention resolution (collision handling)

An optional MAC control sublayer, architecturally positioned between LLC (or other MAC client) and the MAC, is specified in Clause 31. This MAC Control sublayer is transparent to both the underlying MAC and its client (typically LLC). The MAC sublayer operates independently of its client; i.e., it is unaware whether the client is LLC or the MAC Control sublayer. This allows the MAC to be specified and implemented in one manner, whether or not the MAC Control sublayer is implemented. References to LLC as the MAC client in text and figures apply equally to the MAC Control sublayer, if implemented.

This standard provides for two modes of operation of the MAC sublayer:

- a) In *half duplex* mode, stations contend for the use of the physical medium, using the CSMA/CD algorithms specified. Bidirectional communication is accomplished by rapid exchange of frames, rather than full duplex operation. Half duplex operation is possible on all supported media; it is required on those media that are incapable of supporting simultaneous transmission and reception without interference, for example, 10BASE2 and 100BASE-T4.
- b) The *full duplex* mode of operation can be used when all of the following are true:
  - 1) The physical medium is capable of supporting simultaneous transmission and reception without interference (e.g., 10BASE-T, 10BASE-FL, and 100BASE-TX/FX).
  - 2) There are exactly two stations on the LAN. This allows the physical medium to be treated as a full duplex point-to-point link between the stations. Since there is no contention for use of a shared medium, the multiple access (i.e., CSMA/CD) algorithms are unnecessary.
  - 3) Both stations on the LAN are capable of and have been configured to use full duplex operation.

The most common configuration envisioned for full duplex operation consists of a central bridge (also known as a switch) with a dedicated LAN connecting each bridge port to a single device.

The formal specification of the MAC in 4.2 comprises both the half duplex and full duplex modes of operation. The remainder of this clause provides a functional model of the CSMA/CD MAC method.

#### **4.1.2 CSMA/CD operation**

This subclause provides an overview of frame transmission and reception in terms of the functional model of the architecture. This overview is descriptive, rather than definitional; the formal specifications of the operations described here are given in 4.2 and 4.3. Specific implementations for CSMA/CD mechanisms that meet this standard are given in 4.4. Figure 1–1 provides the architectural model described functionally in the subclauses that follow.

The Physical Layer Signaling (PLS) component of the Physical Layer provides an interface to the MAC sublayer for the serial transmission of bits onto the physical media. For completeness, in the operational description that follows some of these functions are included as descriptive material. The concise specification of these functions is given in 4.2 for the MAC functions and in Clause 7 for PLS.

Transmit frame operations are independent from the receive frame operations. A transmitted frame addressed to the originating station will be received and passed to the MAC client at that station. This characteristic of the MAC sublayer may be implemented by functionality within the MAC sublayer or full duplex characteristics of portions of the lower layers.

##### **4.1.2.1 Normal operation**

###### **4.1.2.1.1 Transmission without contention**

When a MAC client requests the transmission of a frame, the Transmit Data Encapsulation component of the CSMA/CD MAC sublayer constructs the frame from the client-supplied data. It prepends a preamble and a Start Frame Delimiter to the beginning of the frame. Using information provided by the client, the CSMA/CD MAC sublayer also appends a Pad at the end of the MAC information field of sufficient length to ensure that the transmitted frame length satisfies a minimum frame-size requirement (see 4.2.3.3). It also prepends destination and source addresses, the length/type field, and appends a frame check sequence to provide for error detection. If the MAC supports the use of client-supplied frame check sequence values, then it shall use the client-supplied value, when present. If the use of client-supplied frame check sequence values is not supported, or if the client-supplied frame check sequence value is not present, then the MAC shall compute this value. The frame is then handed to the Transmit Media Access Management component in the MAC sublayer for transmission.

In half duplex mode, Transmit Media Access Management attempts to avoid contention with other traffic on the medium by monitoring the carrier sense signal provided by the Physical Layer Signaling (PLS) component and deferring to passing traffic. When the medium is clear, frame transmission is initiated (after a brief interframe delay to provide recovery time for other CSMA/CD MAC sublayers and for the physical medium). The MAC sublayer then provides a serial stream of bits to the Physical Layer for transmission.

In half duplex mode, at an operating speed of 1000 Mb/s, the minimum frame size is insufficient to ensure the proper operation of the CSMA/CD protocol for the desired network topologies. To circumvent this problem, the MAC sublayer will append a sequence of extension bits to frames which are less than slotTime bits in length so that the duration of the resulting transmission is sufficient to ensure proper operation of the CSMA/CD protocol.

In half duplex mode, at an operating speed of 1000 Mb/s, the CSMA/CD MAC may optionally transmit additional frames without relinquishing control of the transmission medium, up to a specified limit.

In full duplex mode, there is no need for Transmit Media Access Management to avoid contention with other traffic on the medium. Frame transmission may be initiated after the interframe delay, regardless of the

presence of receive activity. In full duplex mode, the MAC sublayer does not perform either carrier extension or frame bursting.

The Physical Layer performs the task of generating the signals on the medium that represent the bits of the frame. Simultaneously, it monitors the medium and generates the collision detect signal, which in the contention-free case under discussion, remains off for the duration of the frame. A functional description of the Physical Layer is given in Clause 7 and beyond.

When transmission has completed without contention, the CSMA/CD MAC sublayer so informs the MAC client and awaits the next request for frame transmission.

#### **4.1.2.1.2 Reception without contention**

At each receiving station, the arrival of a frame is first detected by the Physical Layer, which responds by synchronizing with the incoming preamble, and by turning on the receiveDataValid signal. As the encoded bits arrive from the medium, they are decoded and translated back into binary data. The Physical Layer passes subsequent bits up to the MAC sublayer, where the leading bits are discarded, up to and including the end of the preamble and Start Frame Delimiter.

Meanwhile, the Receive Media Access Management component of the MAC sublayer, having observed receiveDataValid, has been waiting for the incoming bits to be delivered. Receive Media Access Management collects bits from the Physical Layer entity as long as the receiveDataValid signal remains on. When the receiveDataValid signal is removed, the frame is truncated to an octet boundary, if necessary, and passed to Receive Data Decapsulation for processing.

Receive Data Decapsulation checks the frame's Destination Address field to decide whether the frame should be received by this station. If so, it passes the Destination Address (DA), the Source Address (SA), the Length/Type, the Data and (optionally) the Frame Check Sequence (FCS) fields to the MAC client, along with an appropriate status code, as defined in 4.3.2. It also checks for invalid MAC frames by inspecting the frame check sequence to detect any damage to the frame enroute, and by checking for proper octet-boundary alignment of the end of the frame. Frames with a valid FCS may also be checked for proper octet-boundary alignment.

In half duplex mode, at an operating speed of 1000 Mb/s, frames may be extended by the transmitting station under the conditions described in 4.2.3.4. The extension is discarded by the MAC sublayer of the receiving station, as defined in the procedural model in 4.2.9.

#### **4.1.2.2 Access interference and recovery**

In half duplex mode, if multiple stations attempt to transmit at the same time, it is possible for them to interfere with each other's transmissions, in spite of their attempts to avoid this by deferring. When transmissions from two stations overlap, the resulting contention is called a collision. Collisions occur only in half duplex mode, where a collision indicates that there is more than one station attempting to use the shared physical medium. In full duplex mode, two stations may transmit to each other simultaneously without causing interference. The Physical Layer may generate a collision indication, but this is ignored by the full duplex MAC.

A given station can experience a collision during the initial part of its transmission (the collision window) before its transmitted signal has had time to propagate to all stations on the CSMA/CD medium. Once the collision window has passed, a transmitting station is said to have acquired the medium; subsequent collisions are avoided since all other (properly functioning) stations can be assumed to have noticed the signal and to be deferring to it. The time to acquire the medium is thus based on the round-trip propagation time of the Physical Layer whose elements include the PLS, PMA, and physical medium.

In the event of a collision, the transmitting station's Physical Layer initially notices the interference on the medium and then turns on the collision detect signal. In half duplex mode, this is noticed in turn by the Transmit Media Access Management component of the MAC sublayer, and collision handling begins. First, Transmit Media Access Management enforces the collision by transmitting a bit sequence called jam. In 4.4, implementations that use this enforcement procedure are provided. This ensures that the duration of the collision is sufficient to be noticed by the other transmitting station(s) involved in the collision. After the jam is sent, Transmit Media Access Management terminates the transmission and schedules another transmission attempt after a randomly selected time interval. Retransmission is attempted again in the face of repeated collisions. Since repeated collisions indicate a busy medium, however, Transmit Media Access Management attempts to adjust to the medium load by backing off (voluntarily delaying its own retransmissions to reduce its load on the medium). This is accomplished by expanding the interval from which the random retransmission time is selected on each successive transmit attempt. Eventually, either the transmission succeeds, or the attempt is abandoned on the assumption that the medium has failed or has become overloaded.

In full duplex mode, a station ignores any collision detect signal generated by the Physical Layer. Transmit Media Access Management in a full duplex station will always be able to transmit its frames without contention, so there is never any need to jam or reschedule transmissions.

At the receiving end, the bits resulting from a collision are received and decoded by the PLS just as are the bits of a valid frame. Fragmentary frames received during collisions are distinguished from valid transmissions by the MAC sublayer's Receive Media Access Management component.

#### **4.1.3 Relationships to the MAC client and Physical Layers**

The CSMA/CD MAC sublayer provides services to the MAC client required for the transmission and reception of frames. Access to these services is specified in 4.3. The CSMA/CD MAC sublayer makes a best effort to acquire the medium and transfer a serial stream of bits to the Physical Layer. Although certain errors are reported to the client, error recovery is not provided by MAC. Error recovery may be provided by the MAC client or higher (sub)layers.

### **4.2 CSMA/CD Media Access Control (MAC) method: Precise specification**

#### **4.2.1 Introduction**

A precise algorithmic definition is given in this subclause, providing procedural model for the CSMA/CD MAC process with a program in the computer language Pascal. See references [B13] and [B24] for resource material. Note whenever there is any apparent ambiguity concerning the definition of some aspect of the CSMA/CD MAC method, it is the Pascal procedural specification in 4.2.7 through 4.2.10 which should be consulted for the definitive statement. Subclauses 4.2.2 through 4.2.6 provide, in prose, a description of the access mechanism with the formal terminology to be used in the remaining subclauses.

#### **4.2.2 Overview of the procedural model**

The functions of the CSMA/CD MAC method are presented below, modeled as a program written in the computer language Pascal. This procedural model is intended as the primary specification of the functions to be provided in any CSMA/CD MAC sublayer implementation. It is important to distinguish, however, between the model and a real implementation. The model is optimized for simplicity and clarity of presentation, while any realistic implementation shall place heavier emphasis on such constraints as efficiency and suitability to a particular implementation technology or computer architecture. In this context, several important properties of the procedural model shall be considered.



#### 4.2.2.1 Ground rules for the procedural model

- a) First, it shall be emphasized that *the description of the MAC sublayer in a computer language is in no way intended to imply that procedures shall be implemented as a program executed by a computer*. The implementation may consist of any appropriate technology including hardware, firmware, software, or any combination.
- b) Similarly, it shall be emphasized that it is the behavior of any MAC sublayer implementations that shall match the standard, not their internal structure. The internal details of the procedural model are useful only to the extent that they help specify that behavior clearly and precisely.
- c) The handling of incoming and outgoing frames is rather stylized in the procedural model, in the sense that frames are handled as single entities by most of the MAC sublayer and are only serialized for presentation to the Physical Layer. In reality, many implementations will instead handle frames serially on a bit, octet or word basis. This approach has not been reflected in the procedural model, since this only complicates the description of the functions without changing them in any way.
- d) The model consists of algorithms designed to be executed by a number of concurrent processes; these algorithms collectively implement the CSMA/CD procedure. The timing dependencies introduced by the need for concurrent activity are resolved in two ways:
  - 1) *Processes Versus External Events*. It is assumed that the algorithms are executed “very fast” relative to external events, in the sense that a process never falls behind in its work and fails to respond to an external event in a timely manner. For example, when a frame is to be received, it is assumed that the Media Access procedure ReceiveFrame is always called well before the frame in question has started to arrive.
  - 2) *Processes Versus Processes*. Among processes, no assumptions are made about relative speeds of execution. This means that each interaction between two processes shall be structured to work correctly independent of their respective speeds. Note, however, that the timing of interactions among processes is often, in part, an indirect reflection of the timing of external events, in which case appropriate timing assumptions may still be made.

It is intended that the concurrency in the model reflect the parallelism intrinsic to the task of implementing the MAC client and MAC procedures, although the actual parallel structure of the implementations is likely to vary.

#### 4.2.2.2 Use of Pascal in the procedural model

Several observations need to be made regarding the method with which Pascal is used for the model. Some of these observations are as follows:

- a) The following limitations of the language have been circumvented to simplify the specification:
  - 1) The elements of the program (variables and procedures, for example) are presented in logical groupings, in top-down order. Certain Pascal ordering restrictions have thus been circumvented to improve readability.
  - 2) The *process* and *cycle* constructs of Concurrent Pascal, a Pascal derivative, have been introduced to indicate the sites of autonomous concurrent activity. As used here, a process is simply a parameterless procedure that begins execution at “the beginning of time” rather than being invoked by a procedure call. A cycle statement represents the main body of a process and is executed repeatedly forever.
  - 3) The lack of variable array bounds in the language has been circumvented by treating frames as if they are always of a single fixed size (which is never actually specified). The size of a frame depends on the size of its data field, hence the value of the “pseudo-constant” frameSize should be thought of as varying in the long term, even though it is fixed for any given frame.
  - 4) The use of a variant record to represent a frame (as fields and as bits) follows the spirit but not the letter of the Pascal Report, since it allows the underlying representation to be viewed as two different data types.
- b) The model makes no use of any explicit interprocess synchronization primitives. Instead, all interprocess interaction is done by way of carefully stylized manipulation of shared variables. For

example, some variables are set by only one process and inspected by another process in such a manner that the net result is independent of their execution speeds. While such techniques are not generally suitable for the construction of large concurrent programs, they simplify the model and more nearly resemble the methods appropriate to the most likely implementation technologies (microcode, hardware state machines, etc.)

#### 4.2.2.3 Organization of the procedural model

The procedural model used here is based on seven cooperating concurrent processes. The Frame Transmitter process and the Frame Receiver process are provided by the clients of the MAC sublayer (which may include the LLC sublayer) and make use of the interface operations provided by the MAC sublayer. The other five processes are defined to reside in the MAC sublayer. The seven processes are as follows:

- a) Frame Transmitter process
- b) Frame Receiver process
- c) Bit Transmitter process
- d) Bit Receiver process
- e) Deference process
- f) BurstTimer process
- g) SetExtending process

This organization of the model is illustrated in Figure 4–1 and reflects the fact that the communication of entire frames is initiated by the client of the MAC sublayer, while the timing of collision backoff and of individual bit transfers is based on interactions between the MAC sublayer and the Physical-Layer-dependent bit time.

Figure 4–1 depicts the static structure of the procedural model, showing how the various processes and procedures interact by invoking each other. Figure 4–2a, 4–2b, 4–3a, and 4–3b summarize the dynamic behavior of the model during transmission and reception, focusing on the steps that shall be performed, rather than the procedural structure that performs them. The usage of the shared state variables is not depicted in the figures, but is described in the comments and prose in the following subclauses.

#### 4.2.2.4 Layer management extensions to procedural model

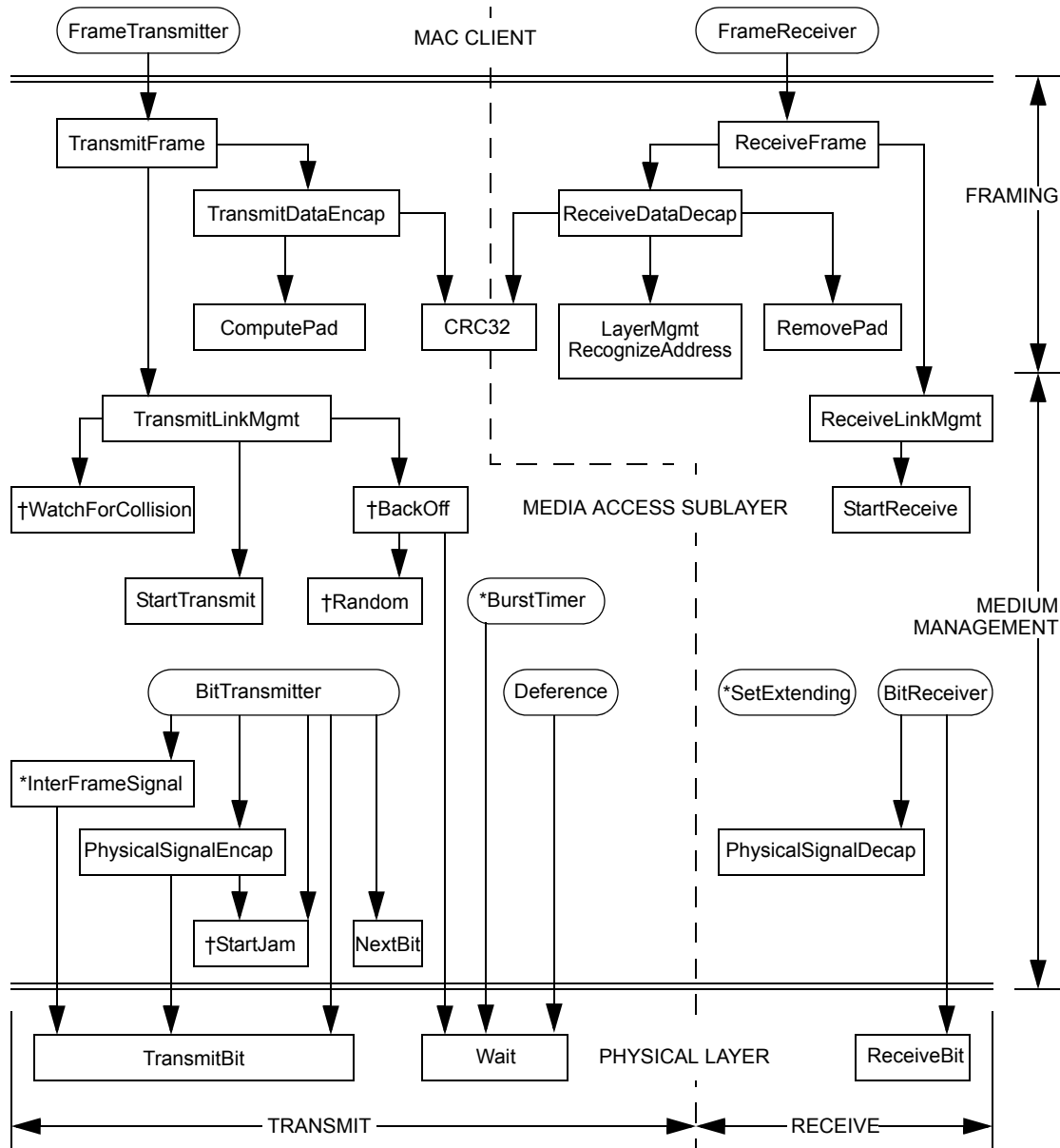
In order to incorporate network management functions, this Procedural Model has been expanded beyond that provided in ISO/IEC 8802-3:1990. Network management functions have been incorporated in two ways. First, 4.2.7–4.2.10, 4.3.2, Figure 4–2a, and Figure 4–2b have been modified and expanded to provide management services. Second, Layer Management procedures have been added as 5.2.4. Note that Pascal variables are shared between Clause 4 and Clause 5. Within the Pascal descriptions provided in Clause 4, a “‡” in the left margin indicates a line that has been added to support management services. These lines are only required if Layer Management is being implemented. These changes do not affect any aspect of the MAC behavior as observed at the LLC-MAC and MAC-PLS interfaces of ISO/IEC 8802-3:1990.

The Pascal procedural specification shall be consulted for the definitive statement when there is any apparent ambiguity concerning the definition of some aspect of the CSMA/CD MAC access method.

The Layer Management facilities provided by the CSMA/CD MAC and Physical Layer management definitions provide the ability to manipulate management counters and initiate actions within the layers. The managed objects within this standard are defined as sets of attributes, actions, notifications, and behaviors in accordance with IEEE Std 802.1F-1993, and ISO/IEC International Standards for network management.

#### 4.2.3 Packet transmission model

Packet transmission includes the following data encapsulation and Media Access management aspects:



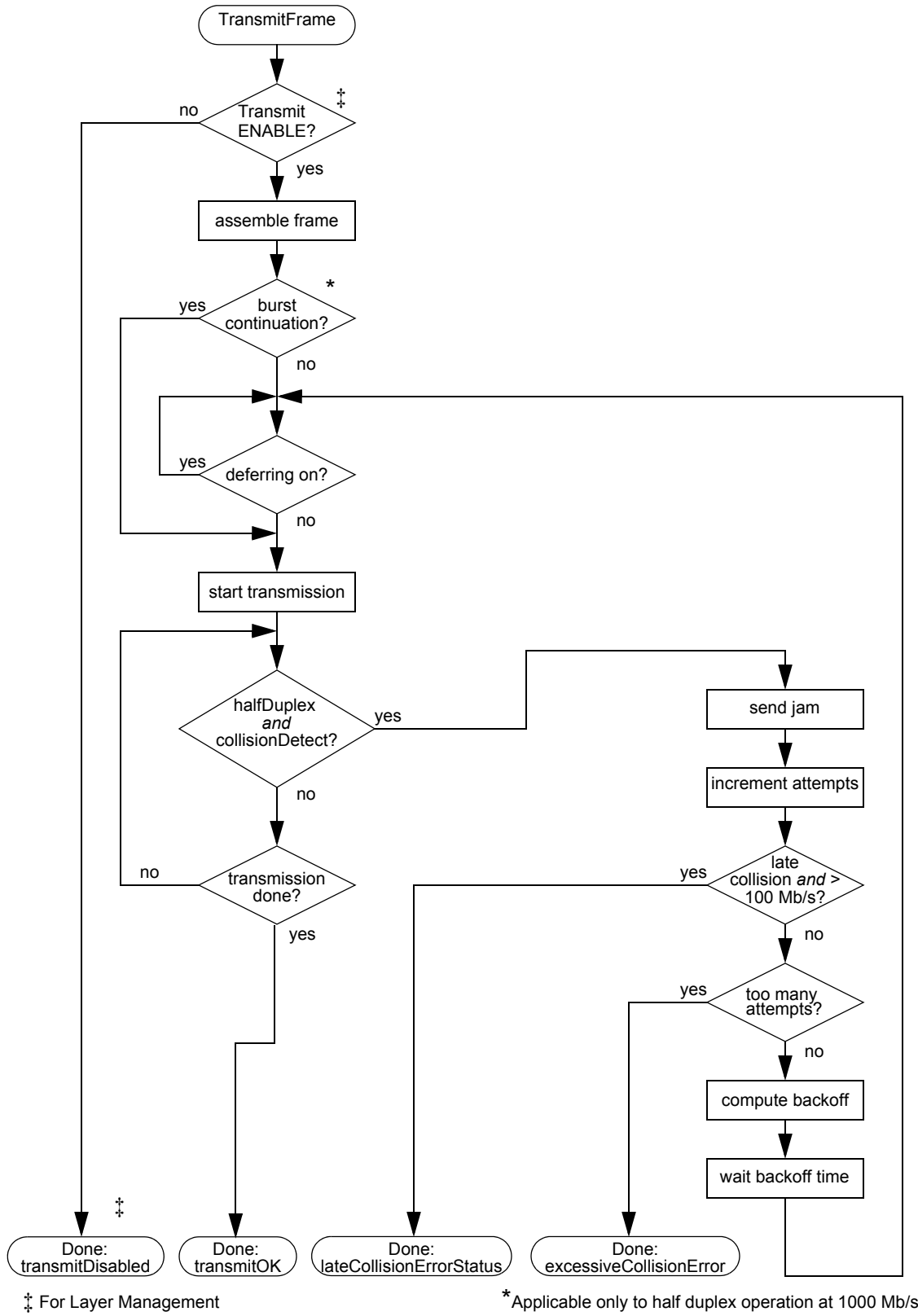
† Not applicable to full duplex operation.  
\* Applicable only to half duplex operation at 1000 Mb/s.

**Figure 4–1—Relationship among CSMA/CD procedures**

- a) Transmit Data Encapsulation includes the assembly of the outgoing packet (from the values provided by the MAC client) and frame check sequence generation (if not provided by the MAC client).
- b) Transmit Media Access Management includes carrier deference, interpacket gap, collision detection and enforcement, collision backoff and retransmission, carrier extension and packet bursting.

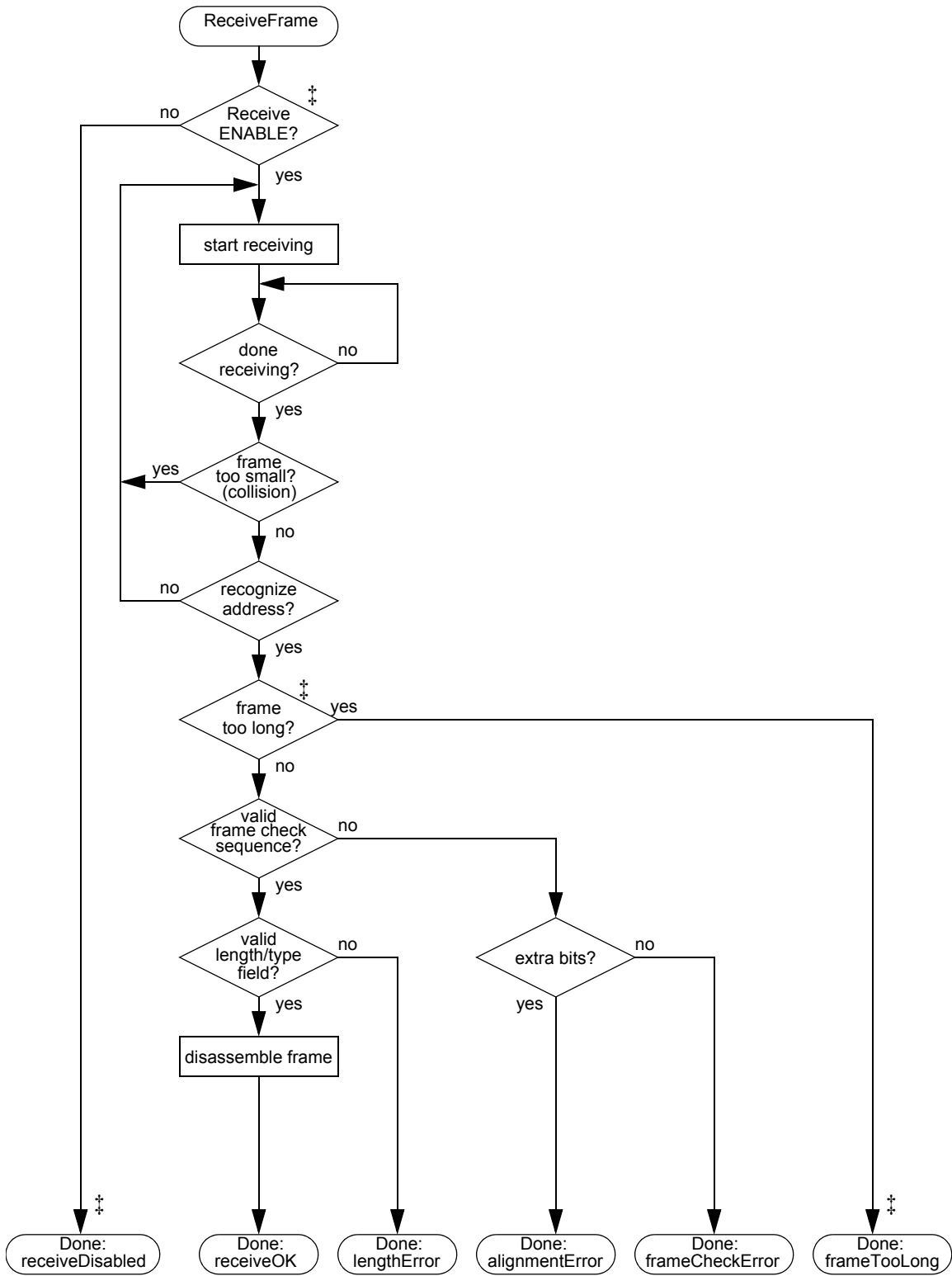
**4.2.3.1 Transmit data encapsulation**

The fields of the CSMA/CD MAC frame are set to the values provided by the MAC client as arguments to the TransmitFrame operation (see 4.3) with the following possible exceptions: the padding field, the extension field, and the frame check sequence. The padding field is necessary to enforce the minimum frame size.



a) TransmitFrame

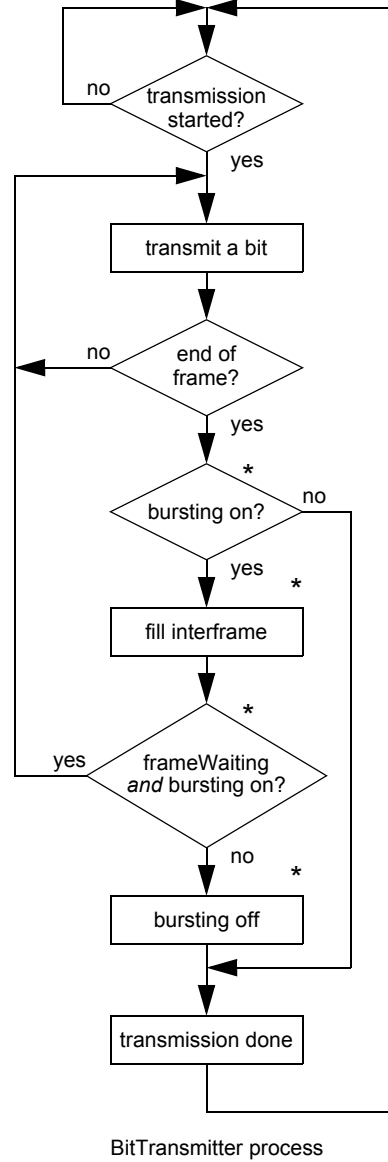
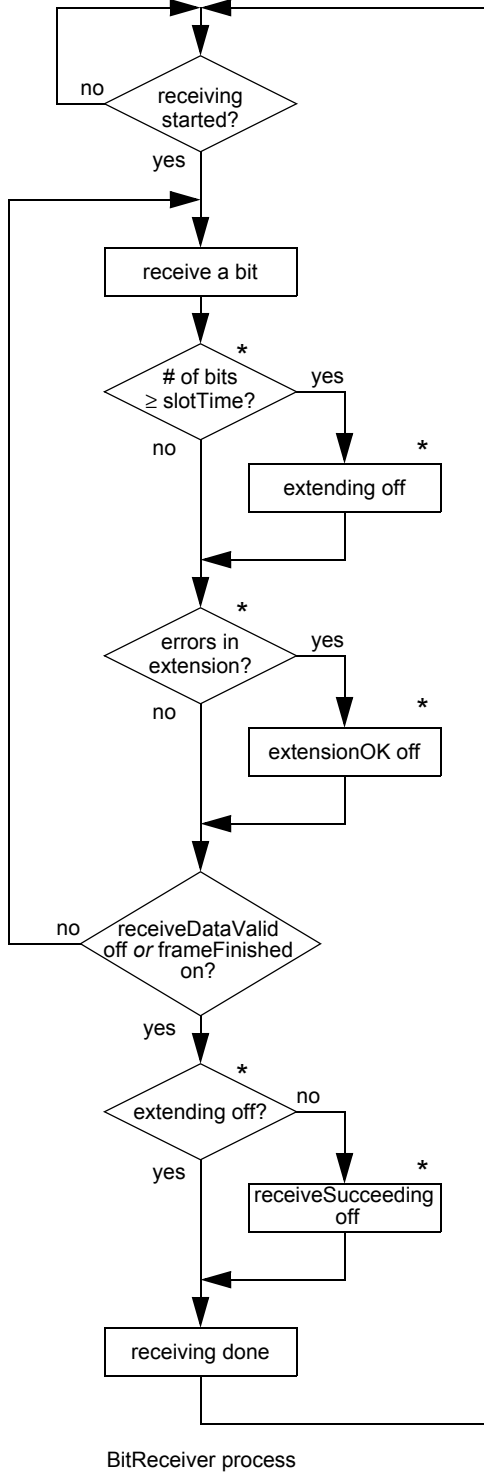
Figure 4-2a—Control flow summary



‡ For Layer Management

b) ReceiveFrame

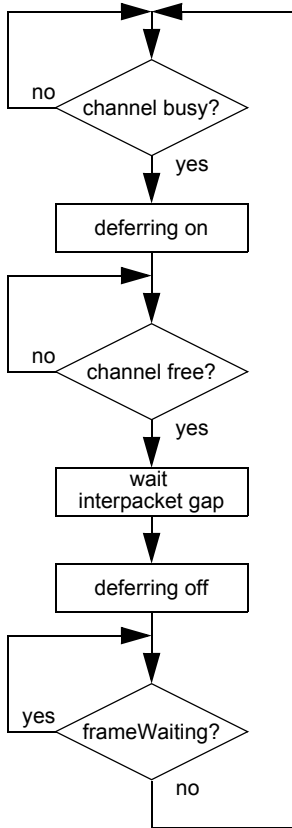
Figure 4-2b—Control flow summary



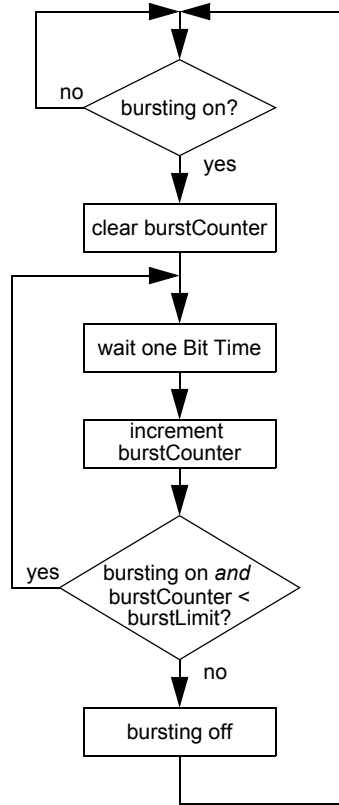
\* Applicable only to half duplex operation at 1000 Mb/s

a) MAC sublayer

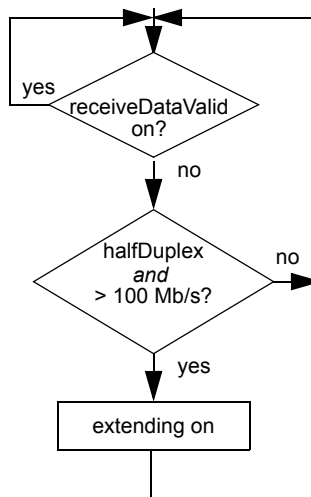
Figure 4-3a—Control flow



Deference process



\*BurstTimer process



\*SetExtending process

\*Applicable only to half duplex operation at 1000 Mb/s

**b) MAC sublayer**

**Figure 4-3b—Control flow**

The extension field is necessary to enforce the minimum carrier event duration on the medium in half duplex mode at an operating speed of 1000 Mb/s. The frame check sequence field may be (optionally) provided as an argument to the MAC sublayer. It is optional for a MAC to support the provision of the frame check sequence in such an argument. If this field is provided by the MAC client, the padding field shall also be provided by the MAC client, if necessary. If this field is not provided by the MAC client, or if the MAC does not support the provision of the frame check sequence as an external argument, it is set to the CRC value generated by the MAC sublayer, after appending the padding field, if necessary.

#### 4.2.3.2 Transmit media access management

##### 4.2.3.2.1 Deference

When a packet is submitted by the MAC client for transmission, the transmission is initiated as soon as possible, but in conformance with the rules of deference stated below. The rules of deference differ between half duplex and full duplex modes.

a) *Half duplex mode*

Even when it has nothing to transmit, the CSMA/CD MAC sublayer monitors the physical medium for traffic by watching the carrierSense signal provided by the PLS. Whenever the medium is busy, the CSMA/CD MAC defers to the passing packet by delaying any pending transmission of its own. After the last bit of the passing packet (that is, when *carrierSense* changes from true to false), the CSMA/CD MAC continues to defer for a proper interPacketGap (see 4.2.3.2.2).

If, at the end of the interPacketGap, a packet is waiting to be transmitted, transmission is initiated independent of the value of carrierSense. When transmission has completed (or immediately, if there was nothing to transmit) the CSMA/CD MAC sublayer resumes its original monitoring of carrierSense.

NOTE—It is possible for the PLS carrier sense indication to fail to be asserted briefly during a collision on the media. If the Deference process simply times the interpacket gap based on this indication it is possible for a short interpacket gap to be generated, leading to a potential reception failure of a subsequent frame. To enhance system robustness the following optional measures, as specified in 4.2.8, are recommended when interPacketGapPart1 is other than zero:

Start the timing of the interPacketGap as soon as transmitting and carrierSense are both false. Reset the interPacketGap timer if carrierSense becomes true during the first 2/3 of the interPacketGap timing interval. During the final 1/3 of the interval, the timer shall not be reset to ensure fair access to the medium. An initial period shorter than 2/3 of the interval is permissible including zero.

b) *Full duplex mode*

In full duplex mode, the CSMA/CD MAC does not defer pending transmissions based on the carrierSense signal from the PLS. Instead, it uses the internal variable *transmitting* to maintain proper MAC state while the transmission is in progress. After the last bit of a transmitted frame, (that is, when *transmitting* changes from true to false), the MAC continues to defer for a proper interPacketGap (see 4.2.3.2.2).

##### 4.2.3.2.2 Interpacket gap

As defined in 4.2.3.2.1, the rules for deferring to passing packets ensure a minimum interpacket spacing of interPacketGap bit times. This is intended to provide interpacket recovery time for other CSMA/CD sublayers and for the physical medium.

Note that interPacketGap is the minimum value of the interpacket gap. If necessary for implementation reasons, a transmitting sublayer may use a larger value with a resulting decrease in its throughput. The larger value is determined by the parameters of the implementation, see 4.4.



A larger value for interpacket gap is used for dynamically adapting the nominal data rate of the MAC sublayer to SONET/SDH data rates (with packet granularity) for WAN-compatible applications of this standard. While in this optional mode of operation, the MAC sublayer counts the number of bits sent during a frame's transmission. After the packet's transmission has been completed, the MAC sublayer extends the minimum interpacket gap by a number of bits that is proportional to the length of the previously transmitted packet. For more details, see 4.2.7 and 4.2.8.

#### 4.2.3.2.3 Collision handling (half duplex mode only)

Once a CSMA/CD sublayer has finished deferring and has started transmission, it is still possible for it to experience contention for the medium. Collisions can occur until acquisition of the network has been accomplished through the deference of all other stations' CSMA/CD sublayers.

The dynamics of collision handling are largely determined by a single parameter called the slot time. This single parameter describes three important aspects of collision handling:

- a) It is an upper bound on the acquisition time of the medium.
- b) It is an upper bound on the length of a packet fragment generated by a collision.
- c) It is the scheduling quantum for retransmission.

To fulfill all three functions, the slot time shall be larger than the sum of the Physical Layer round-trip propagation time and the Media Access Layer maximum jam time. The slot time is determined by the parameters of the implementation, see 4.4.

#### 4.2.3.2.4 Collision detection and enforcement (half duplex mode only)

Collisions are detected by monitoring the collisionDetect signal provided by the Physical Layer. When a collision is detected during a packet transmission, the transmission is not terminated immediately. Instead, the transmission continues until additional bits specified by jamSize have been transmitted (counting from the time collisionDetect went on). This collision enforcement or jam guarantees that the duration of the collision is sufficient to ensure its detection by all transmitting stations on the network. The content of the jam is unspecified; it may be any fixed or variable pattern convenient to the Media Access implementation; however, the implementation shall not be intentionally designed to be the 32-bit CRC value corresponding to the (partial) packet transmitted prior to the jam.

#### 4.2.3.2.5 Collision backoff and retransmission (half duplex mode only)

When a transmission attempt has terminated due to a collision, it is retried by the transmitting CSMA/CD sublayer until either it is successful or a maximum number of attempts (attemptLimit) have been made and all have terminated due to collisions. Note that all attempts to transmit a given packet are completed before any subsequent outgoing packets are transmitted. The scheduling of the retransmissions is determined by a controlled randomization process called "truncated binary exponential backoff." At the end of enforcing a collision (jamming), the CSMA/CD sublayer delays before attempting to retransmit the packet. The delay is an integer multiple of slotTime. The number of slot times to delay before the  $n$ th retransmission attempt is chosen as a uniformly distributed random integer  $r$  in the range:

$$0 \leq r < 2^k$$

where

$$k = \min(n, 10)$$

If all attemptLimit attempts fail, this event is reported as an error. Algorithms used to generate the integer  $r$  should be designed to minimize the correlation between the numbers generated by any two stations at any given time.

Note that the values given above define the most aggressive behavior that a station may exhibit in attempting to retransmit after a collision. In the course of implementing the retransmission scheduling procedure, a station may introduce extra delays that will degrade its own throughput, but in no case may a station's retransmission scheduling result in a lower average delay between retransmission attempts than the procedure defined above.

#### 4.2.3.2.6 Full duplex transmission

In full duplex mode, there is never contention for a shared physical medium. The Physical Layer may indicate to the MAC that there are simultaneous transmissions by both stations, but since these transmissions do not interfere with each other, a MAC operating in full duplex mode must not react to such Physical Layer indications. Full duplex stations do not defer to received traffic, nor abort transmission, jam, backoff, and reschedule transmissions as part of Transmit Media Access Management. Transmissions may be initiated whenever the station has a packet queued, subject only to the interpacket gap required to allow recovery for other sublayers and for the physical medium.

#### 4.2.3.2.7 Packet bursting (half duplex mode only)

At an operating speed of 1000 Mb/s, an implementation may optionally transmit a series of packets without relinquishing control of the transmission medium. This mode of operation is referred to as *burst mode*. Once a packet has been successfully transmitted, the transmitting station can begin transmission of another packet without contending for the medium because all of the other stations on the network will continue to defer to its transmission, provided that it does not allow the medium to assume an idle condition between packets. The transmitting station fills the interpacket gap interval with extension bits, which are readily distinguished from data bits at the receiving stations, and which maintain the detection of carrier in the receiving stations. The transmitting station is allowed to initiate packet transmission until a specified limit, referred to as burstLimit, is reached. The value of burstLimit is specified in 4.4.2. Figure 4–4 shows an example of transmission with packet bursting.

The first packet of a burst will be extended, if necessary, as described in 4.2.3.4. Subsequent packets within a burst do not require extension. In a properly configured network, and in the absence of errors, collisions cannot occur during a burst at any time after the first packet of a burst (including any extension) has been transmitted. Therefore, the MAC will treat any collision that occurs after the first packet of a burst, or that occurs after the slotTime has been reached in the first packet of a burst, as a late collision.

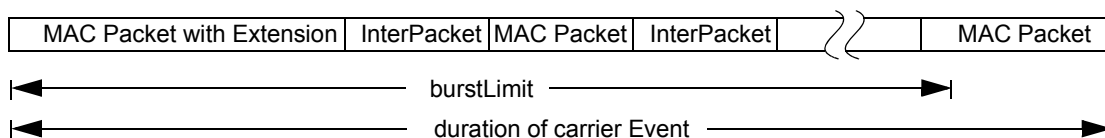


Figure 4–4—Packet bursting

#### 4.2.3.3 Minimum frame size

The CSMA/CD Media Access mechanism requires that a minimum frame length of minFrameSize bits be transmitted. If frameSize is less than minFrameSize, then the CSMA/CD MAC sublayer shall append extra bits in units of octets (Pad), after the end of the MAC Client Data field but prior to calculating and appending the FCS (if not provided by the MAC client). The number of extra bits shall be sufficient to ensure that the frame, from the DA field through the FCS field inclusive, is at least minFrameSize bits. If the FCS is

(optionally) provided by the MAC client, the Pad shall also be provided by the MAC client. The content of the Pad is unspecified.

#### 4.2.3.4 Carrier extension (half duplex mode only)

At an operating speed of 1000 Mb/s, the slotTime employed at slower speeds is inadequate to accommodate network topologies of the desired physical extent. Carrier Extension provides a means by which the slotTime can be increased to a sufficient value for the desired topologies, without increasing the minFrameSize parameter, as this would have deleterious effects. Non-data bits, referred to as extension bits, are appended to frames that are less than slotTime bits in length so that the resulting transmission is at least one slotTime in duration. Carrier Extension can be performed only if the underlying Physical Layer is capable of sending and receiving symbols that are readily distinguished from data symbols, as is the case in most Physical Layers that use a block encoding/decoding scheme. The maximum length of the extension is equal to the quantity (slotTime – minFrameSize). Figure 4–5 depicts a frame with carrier extension.

The MAC continues to monitor the medium for collisions while it is transmitting extension bits, and it will treat any collision that occurs after the threshold (slotTime) as a late collision.

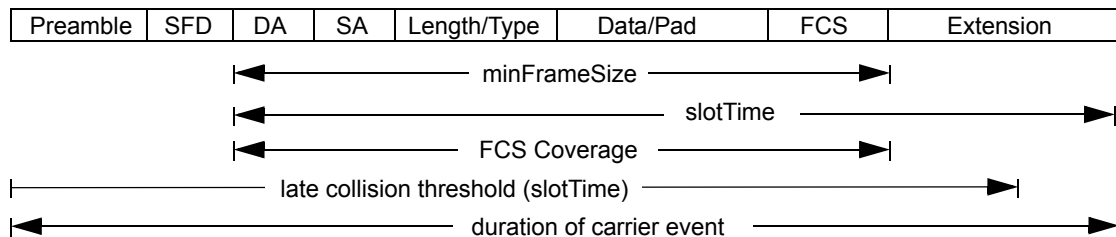


Figure 4–5—Frame with carrier extension

#### 4.2.4 Frame reception model

CSMA/CD MAC sublayer frame reception includes both data decapsulation and Media Access management aspects:

- Receive Data Decapsulation comprises address recognition, frame check sequence validation, and frame disassembly to pass the fields of the received frame to the MAC client.
- Receive Media Access Management comprises recognition of collision fragments from incoming frames and truncation of frames to octet boundaries.

##### 4.2.4.1 Receive data decapsulation

###### 4.2.4.1.1 Address recognition

The CSMA/CD MAC sublayer is capable of recognizing individual and group addresses.

- Individual Addresses.* The CSMA/CD MAC sublayer recognizes and accepts any frame whose DA field contains the individual address of the station.
- Group Addresses.* The CSMA/CD MAC sublayer recognizes and accepts any frame whose DA field contains the Broadcast address.

The CSMA/CD MAC sublayer is capable of activating some number of group addresses as specified by higher layers. The CSMA/CD MAC sublayer recognizes and accepts any frame whose Destination Address field contains an active group address. An active group address may be deactivated.

The MAC sublayer may also provide the capability of operating in the promiscuous receive mode. In this mode of operation, the MAC sublayer recognizes and accepts all valid frames, regardless of their Destination Address field values.

#### 4.2.4.1.2 Frame check sequence validation

FCS validation is essentially identical to FCS generation. If the bits of the incoming frame (exclusive of the FCS field itself) do not generate a CRC value identical to the one received, an error has occurred and the frame is identified as invalid.

#### 4.2.4.1.3 Frame disassembly

Upon recognition of the Start Frame Delimiter at the end of the preamble sequence, the CSMA/CD MAC sublayer accepts the frame. If there are no errors, the frame is disassembled and the fields are passed to the MAC client by way of the output parameters of the ReceiveFrame operation.

#### 4.2.4.2 Receive media access management

##### 4.2.4.2.1 Framing

The CSMA/CD sublayer recognizes the boundaries of an incoming MAC frame by monitoring the receive-DataValid signal provided by the Physical Layer. Two possible length errors can occur that indicate ill-framed data: the MAC frame may be too long, or its length may not be an integer number of octets.

- a) *Maximum Frame Size.* The receiving CSMA/CD sublayer is not required to enforce the MAC frame size limit, but it is allowed to truncate MAC frames longer than `maxFrameSizeLimit` octets (see 4.2.7.1). If optional layer management is implemented, such frames may be counted whether or not they are truncated. They may also be reported as an implementation-dependent error.

**CAUTION**

It is recommended that any implementation that truncates MAC frames should invalidate those frames as they may have severely weakened error protection and may cause serious problems if forwarded to the MAC client.

- b) *Integer Number of Octets in Frame.* Since the format of a valid MAC frame specifies an integer number of octets, only a collision or an error can produce a MAC frame with a length that is not an integer multiple of 8 bits. Complete MAC frames (that is, not rejected as collision fragments; see 4.2.4.2.2) that do not contain an integer number of octets are truncated to the nearest octet boundary. If frame check sequence validation detects an error in such a MAC frame, the status code `alignmentError` is reported.

When a burst of MAC frames is received while operating in half duplex mode at an operating speed of 1000 Mb/s, the individual MAC frames within the burst are delimited by sequences of interpacket fill symbols, which are conveyed to the receiving MAC sublayer as extension bits. Once the collision filtering requirements for a given MAC frame, as described in 4.2.4.2.2, have been satisfied, the receipt of an extension bit can be used as an indication that all of the data bits of the MAC frame have been received.

##### 4.2.4.2.2 Collision filtering

In the absence of a collision, the shortest valid transmission in half duplex mode must be at least one `slotTime` in length. Within a burst of frames, the first frame of a burst must be at least `slotTime` bits in length in order to be accepted by the receiver, while subsequent frames within a burst must be at least `minFrameSize` in length. Anything less is presumed to be a fragment resulting from a collision, and is discarded by the receiver. In half duplex mode, occasional collisions are a normal part of the Media Access management procedure. The discarding of such a fragment by a MAC is not reported as an error.

The shortest valid transmission in full duplex mode must be at least `minFrameSize` in length. While collisions do not occur in full duplex mode MACs, a full duplex MAC nevertheless discards received frames containing less than `minFrameSize` bits. The discarding of such a frame by a MAC is not reported as an error.

#### 4.2.5 Preamble generation

In a LAN implementation, most of the Physical Layer components are allowed to provide valid output some number of bit times after being presented valid input signals. Thus it is necessary for a preamble to be sent before the start of data, to allow the PLS circuitry to reach its steady state. Upon request by `TransmitLinkMgmt` to transmit the first bit of a new frame, `PhysicalSignalEncap` shall first transmit the preamble, a bit sequence used for physical medium stabilization and synchronization, followed by the Start Frame Delimiter. If, while transmitting the preamble or Start Frame Delimiter, the collision detect variable becomes true, any remaining preamble and Start Frame Delimiter bits shall be sent. The preamble pattern is:

```
10101010 10101010 10101010 10101010 10101010 10101010 10101010
```

The bits are transmitted in order, from left to right. The nature of the pattern is such that, for Manchester encoding, it appears as a periodic waveform on the medium that enables bit synchronization. It should be noted that the preamble ends with a “0.”

#### 4.2.6 Start frame sequence

The `receiveDataValid` signal is the indication to the MAC that the frame reception process should begin. Upon reception of the sequence 10101011 following the assertion of `receiveDataValid`, `PhysicalSignalDecap` shall begin passing successive bits to `ReceiveLinkMgmt` for passing to the MAC client.

#### 4.2.7 Global declarations

This subclause provides detailed formal specifications for the CSMA/CD MAC sublayer. It is a specification of generic features and parameters to be used in systems implementing this media access method. Subclause 4.4 provides values for these sets of parameters for recommended implementations of this media access mechanism.

##### 4.2.7.1 Common constants, types, and variables

The following declarations of constants, types and variables are used by the MAC frame transmission and reception sections of each CSMA/CD sublayer:

```
const
  addressSize = 48; {In bits, in compliance with 3.2.3}
  lengthOrTypeSize = 16; {In bits}
  clientDataSize = ...; {In bits, size of MAC Client Data; see 4.2.2.2, a) 3)}
  padSize = ...; {In bits, = max (0, minFrameSize – (2 x addressSize + lengthOrTypeSize +
                                clientDataSize + crcSize))}
  dataSize = ...; {In bits, = clientDataSize + padSize}
  crcSize = 32; {In bits, 32-bit CRC}
  frameSize = ...; {In bits, = 2 x addressSize + lengthOrTypeSize + dataSize + crcSize; see 4.2.2.2, a)}
  minFrameSize = ...; {In bits, see 4.4}
  maxBasicFrameSize = 1518; {In octets, see 3.2.7, 4.4}
  maxEnvelopeFrameSize = 2000; {In octets, see 3.2.7, 4.4}
  qTagPrefixSize = 4; {In octets, length of Q-tag prefix, see 3.2.7, 4.4}
  maxFrameSizeLimit = maxBasicFrameSize or (maxBasicFrameSize + qTagPrefixSize) or
    maxEnvelopeFrameSize ; {in octets}
```

```

extend = ...; {Boolean, true if (slotTime — minFrameSize) > 0, false otherwise}
extensionBit = ...; {A non-data value which is used for carrier extension and interpacket
    during bursts}
extensionErrorBit = ...; {A non-data value which is used to jam during carrier extension}
minTypeValue = 1536; {Minimum value of the Length/Type field for Type interpretation}
maxBasicDataSize = 1500;
    {In octets, the maximum length of the MAC Client Data field of the basic frame.}
slotTime = ...; {In bit times, unit of time for collision handling, implementation-dependent, see 4.4}
preambleSize = 56; {In bits, see 4.2.5}
sfdSize = 8; {In bits, Start Frame Delimiter}
headerSize = 64; {In bits, sum of preambleSize and sfdSize}
type
    Bit = (0, 1);
    PhysicalBit = (0, 1, extensionBit, extensionErrorBit);
        {Bits transmitted to the Physical Layer can be either 0, 1, extensionBit or
        extensionErrorBit. Bits received from the Physical Layer can be either 0, 1
        or extensionBit}
    AddressValue = array [1..addressSize] of Bit;
    LengthOrTypeValue = array [1..lengthOrTypeSize] of Bit;
    DataValue = array [1..dataSize] of Bit; {Contains the portion of the MAC frame that starts with the first
        bit following the Length/Type field and ends with the last bit
        prior to the FCS field.}
    CRCValue = array [1..crcSize] of Bit;
    PreambleValue = array [1..preambleSize] of Bit;
    SfdValue = array [1..sfdSize] of Bit;
    ViewPoint = (fields, bits); {Two ways to view the contents of a frame}
    HeaderViewPoint = (headerFields, headerBits);
    Frame = record {Format of MAC frame}
        case view: ViewPoint of
            fields: (
                destinationField: AddressValue;
                sourceField: AddressValue;
                lengthOrTypeField: LengthOrTypeValue;
                dataField: DataValue;
                fcsField: CRCValue);
            bits: (contents: array [1..frameSize] of Bit)
        end; {MAC frame}
    Header = record {Format of Preamble and Start Frame Delimiter}
        case headerView: HeaderViewPoint of
            headerFields: (
                preamble: PreambleValue;
                sfd: SfdValue);
            headerBits: (headerContents: array [1..headerSize] of Bit)
        end; {Defines header for MAC frame}
    TransmitStatus = (transmitOK, excessiveCollisionError, lateCollisionErrorStatus);
‡ TransmitStatus = (transmitDisabled, transmitOK, excessiveCollisionError,
    lateCollisionErrorStatus);
    ReceiveStatus = (receiveOK, lengthError, frameCheckError, alignmentError);
‡ ReceiveStatus = (receiveDisabled, receiveOK, frameTooLong, frameCheckError,
    lengthError, alignmentError);
var
    halfDuplex: Boolean; {Indicates the desired mode of operation. halfDuplex is a static variable; its value
        shall only be changed by the invocation of the Initialize procedure}

```

**4.2.7.2 Transmit state variables**

The following items are specific to packet transmission. (See also 4.4.)

*const*

interPacketGap = ...; {In bit times, minimum gap between packets, see 4.4}  
interPacketGapPart1 = ...; {In bit times, duration of the first portion of  
interPacketGap. In the  
range of 0 to 2/3 of interPacketGap}  
interPacketGapPart2 = ...; {In bit times, duration of the remainder of  
interPacketGap. Equal to  
interPacketGap –  
interPacketGapPart1}  
ipgStretchRatio = ...; {In bits, determines the number of bits in a packet that  
require one octet of interPacketGap extension,  
when ipgStretchMode is enabled;  
see 4.4 and 4.2.8}  
attemptLimit = ...; {Max number of times to attempt transmission}  
backOffLimit = ...; {Limit on number of times to back off}  
burstLimit= ...; {In bits, limit for initiation of packet transmission in Burst Mode,  
see 4.4 and 4.2.8}  
jamSize = ...; {In bits, the value depends upon port type and duplex/half-duplex mode.  
See 4.1.2.2 and 4.4.}

*var*

outgoingFrame: Frame; {The frame to be transmitted}  
outgoingHeader: Header;  
currentTransmitBit, lastTransmitBit: 1..frameSize; {Positions of current and last outgoing bits in  
outgoingFrame}  
lastHeaderBit: 1..headerSize;  
deferring: Boolean; {Implies any pending transmission must wait for the medium to clear}  
frameWaiting: Boolean; {Indicates that outgoingFrame is deferring}  
attempts: 0..attemptLimit; {Number of transmission attempts on outgoingFrame}  
newCollision: Boolean; {Indicates that a collision has occurred but has not yet been jammed}  
transmitSucceeding: Boolean; {Running indicator of whether transmission is succeeding}  
burstMode: Boolean; {Indicates the desired mode of operation, and enables the transmission of  
multiple frames in a single carrier event. burstMode is a static variable; its  
value shall only be changed by the invocation of the Initialize procedure}  
bursting: Boolean; {In burstMode, the given station has acquired the medium and the burst timer has  
not yet expired}  
burstStart: Boolean; {In burstMode, indicates that the first frame transmission is in progress}  
extendError: Boolean; {Indicates a collision occurred while sending extension bits}  
ipgStretchMode: Boolean; {Indicates the desired mode of operation, and enables  
the lowering of the average data rate  
of the MAC sublayer (with packet granularity), using  
extension of the minimum interPacketGap.  
ipgStretchMode is a static  
variable; its value shall only be changed by the invocation of the Initialize  
procedure}  
ipgStretchCount: 0..ipgStretchRatio; {In bits, a running  
counter that counts the number of bits during a  
packet's transmission that are to be considered for the  
minimum interPacketGap extension,  
while operating in ipgStretchMode}  
ipgStretchSize: 0..((maxFrameSizeLimit) × 8 + headerSize + interPacketGap

```

+ ipgStretchRatio – 1) div ipgStretchRatio);
{In octets, a running counter that counts the integer number of octets that are to be
added to the minimum interPacketGap, while operating in
ipgStretchMode}

```

#### 4.2.7.3 Receive state variables

The following items are specific to frame reception. (See also 4.4.)

```

var
incomingFrame: Frame; {The frame being received}
receiving: Boolean; {Indicates that a frame reception is in progress}
excessBits: 0..7; {Count of excess trailing bits beyond octet boundary}
receiveSucceeding: Boolean; {Running indicator of whether reception is succeeding}
validLength: Boolean; {Indicator of whether received frame has a length error}
exceedsMaxLength: Boolean; {Indicator of whether received frame has a length longer than the
maximum permitted length}
extending: Boolean; {Indicates whether the current frame is subject to carrier extension}
extensionOK: Boolean; {Indicates whether any bit errors were found in the extension part of a packet,
which is not checked by the CRC}
passReceiveFCSEMode: Boolean; {Indicates the desired mode of operation, and enables passing of
the frame check sequence field of all received frames from the
MAC sublayer to the MAC client. passReceiveFCSEMode is a
static variable}

```

#### 4.2.7.4 State variable initialization

The procedure Initialize must be run when the MAC sublayer begins operation, before any of the processes begin execution. Initialize sets certain crucial shared state variables to their initial values. (All other global variables are appropriately reinitialized before each use.) Initialize then waits for the medium to be idle, and starts operation of the various processes.

NOTE—Care should be taken to ensure that the time from the completion of the Initialize process to when the first packet transmission begins is at least an interPacketGap.

If Layer Management is implemented, the Initialize procedure shall only be called as the result of the initializeMAC action (30.3.1.2.1).

```

procedure Initialize;
begin
frameWaiting := false;
deferring := false;
newCollision := false;
transmitting := false; {An interface to Physical Layer; see below}
receiving := false;
halfDuplex := ...; {True for half duplex operation, false for full duplex operation. For operation at
speeds above 1000 Mb/s, halfDuplex shall always be false}
bursting := false;
burstMode := ...; { True for half duplex operation at an operating speed of 1000
Mb/s, when multiple frames' transmission in a single carrier event is desired and
supported, false otherwise}
extending := extend and halfDuplex;
ipgStretchMode := ...; {True for operating speeds above 1000 Mb/s when lowering the average data rate
of the MAC sublayer (with frame granularity) is desired and supported, false

```



```

                                otherwise}
    ipgStretchCount := 0;
    ipgStretchSize := 0;
    passReceiveFCSEMode := ...; {True when enabling the passing of the frame check sequence of all
                                received frames from the MAC sublayer to the MAC client is desired and
                                supported, false otherwise}
    if halfDuplex then while carrierSense or receiveDataValid do nothing
    else while receiveDataValid do nothing
    {Start execution of all processes}
end; {Initialize}

```

#### 4.2.8 Frame transmission

The algorithms in this subclause define MAC sublayer frame transmission. The function `TransmitFrame` implements the frame transmission operation provided to the MAC client.

The `TransmitFrame` operation is synchronous. Its duration is the entire attempt to transmit the frame; when the operation completes, transmission has either succeeded or failed, as indicated by the `TransmitStatus` status code.

The `transmitDisabled` status code (if layer management is implemented) indicates that the transmitter is not enabled. Successful transmission is indicated by the status code `transmitOK`. The code `excessiveCollisionError` indicates that the transmission attempt was aborted due to excessive collisions, because of heavy traffic or a network failure. MACs operating in the half duplex mode at the speed of 1000 Mb/s are required to report `lateCollisionErrorStatus` in response to a late collision; MACs operating in the half duplex mode at speeds of 100 Mb/s and below are not required to do so. `TransmitStatus` is not used by the service interface defined in 2.3.1. `TransmitStatus` may be used in an implementation dependent manner.

```

function TransmitFrame (
    destinationParam: AddressValue;
    sourceParam: AddressValue;
    lengthOrTypeParam: LengthOrTypeValue;
    dataParam: DataValue;
    fcsParamValue: CRCValue;
    fcsParamPresent: Bit): TransmitStatus;
procedure TransmitDataEncap; {Nested procedure; see body below}
begin
    if transmitEnabled then
        begin
            TransmitDataEncap;
            TransmitFrame := TransmitLinkMgmt
        end
    else TransmitFrame := transmitDisabled
end; {TransmitFrame}

```

If transmission is enabled, `TransmitFrame` calls the internal procedure `TransmitDataEncap` to construct the frame. Next, `TransmitLinkMgmt` is called to perform the actual transmission. The `TransmitStatus` returned indicates the success or failure of the transmission attempt.

`TransmitDataEncap` builds the frame and places the 32-bit CRC in the frame check sequence field:

```

procedure TransmitDataEncap;
begin

```

```

with outgoingFrame do
  begin {Assemble frame}
    view := fields;
    destinationField := destinationParam;
    sourceField := sourceParam;
    lengthOrTypeField := lengthOrTypeParam;
    if fcsParamPresent then
      begin
        dataField := dataParam; {No need to generate pad if the FCS is passed from MAC client}
        fcsField := fcsParamValue {Use the FCS passed from MAC client}
      end
    else
      begin
        dataField := ComputePad(dataParam);
        fcsField := CRC32(outgoingFrame)
      end;
    view := bits
  end {Assemble frame}
with outgoingHeader do
  begin
    headerView := headerFields;
    preamble := ...; {* '1010...10,' LSB to MSB*}
    sfd := ...; {* '10101011,' LSB to MSB*}
    headerView := headerBits
  end
end; {TransmitDataEncap}

```

If the MAC client chooses to generate the frame check sequence field for the frame, it passes this field to the MAC sublayer via the `fcsParamValue` parameter. If the `fcsParamPresent` parameter is true, `TransmitDataEncap` uses the `fcsParamValue` parameter as the frame check sequence field for the frame. Such a frame shall not require any padding, since it is the responsibility of the MAC client to ensure that the frame meets the `minFrameSize` constraint. If the `fcsParamPresent` parameter is false, the `fcsParamValue` parameter is unspecified. `TransmitDataEncap` first calls the `ComputePad` function, followed by a call to the `CRC32` function to generate the padding (if necessary) and the frame check sequence field for the frame internally to the MAC sublayer.

`ComputePad` appends an array of arbitrary bits to the MAC client data to pad the frame to the minimum frame size:

```

function ComputePad(var dataParam: DataValue): DataValue;
begin
  ComputePad := {Append an array of size padSize of arbitrary bits to the MAC client dataField}
end; {ComputePad}

```

`TransmitLinkMgmt` attempts to transmit the frame. In half duplex mode, it first defers to any passing traffic. In half duplex mode, if a collision occurs, transmission is terminated properly and retransmission is scheduled following a suitable backoff interval:

```

function TransmitLinkMgmt: TransmitStatus;
begin
  attempts := 0;
  transmitSucceeding := false;
  lateCollisionCount := 0;

```

```

deferred := false; {Initialize}
excessDefer := false;
while (attempts < attemptLimit) and (not transmitSucceeding)
    and (not extend or lateCollisionCount = 0) do
    {No retransmission after late collision if operating at 1000 Mb/s}
begin {Loop}
    if bursting then {This is a burst continuation}
        frameWaiting := true {Start transmission without checking deference}
    else {Non bursting case, or first frame of a burst}
        begin
            if attempts > 0 then BackOff;
            frameWaiting := true;
            while deferring do {Defer to passing frame, if any21}
                if halfDuplex then deferred := true;
            burstStart := true;
            if burstMode then bursting := true
        end;
        lateCollisionError := false;
        StartTransmit;
        frameWaiting := false;
        if halfDuplex then
            begin
                while transmitting do WatchForCollision;
                if lateCollisionError then lateCollisionCount := lateCollisionCount + 1;
                attempts := attempts + 1
            end {Half duplex mode}
        else while transmitting do nothing {Full duplex mode}
    end; {Loop}
    LayerMgmtTransmitCounters; {Update transmit and transmit error counters in 5.2.4.2}
    if transmitSucceeding then
        begin
            if burstMode then burstStart := false; {Can't be the first frame anymore}
            TransmitLinkMgmt := transmitOK
        end
    else if (extend and lateCollisionCount > 0) then TransmitLinkMgmt := lateCollisionErrorStatus;
    else TransmitLinkMgmt := excessiveCollisionError
end; {TransmitLinkMgmt}

```

Each time a frame transmission attempt is initiated, StartTransmit is called to alert the BitTransmitter process that bit transmission should begin:

```

procedure StartTransmit;
begin
    currentTransmitBit := 1;
    lastTransmitBit := frameSize;
    lastHeaderBit := headerSize;
    transmitSucceeding := true;
    transmitting := true
end; {StartTransmit}

```

<sup>21</sup> The Deference process ensures that the reception of traffic does not cause deferring to be true when in full duplex mode. Deferring is used in full duplex mode to enforce the minimum interpacket gap spacing.

In half duplex mode, TransmitLinkMgmt monitors the medium for contention by repeatedly calling WatchForCollision, once frame transmission has been initiated:

```

procedure WatchForCollision;
begin
  if transmitSucceeding and collisionDetect then
    begin
      if currentTransmitBit > (slotTime – headerSize) then lateCollisionError := true;
      newCollision := true;
      transmitSucceeding := false;
      if burstMode then
        begin
          bursting := false;
          if not burstStart then
            lateCollisionError := true {Every collision is late, unless it hits the first frame in a burst}
          end
        end
      end; {WatchForCollision}

```

WatchForCollision, upon detecting a collision, updates newCollision to ensure proper jamming by the BitTransmitter process. The current transmit bit number is checked to see if this is a late collision. If the collision occurs later than a collision window of slotTime bits into the packet, it is considered as evidence of a late collision. The point at which the collision is received is determined by the network media propagation time and the delay time through a station and, as such, is implementation-dependent (see 4.1.2.2). While operating at speeds of 100 Mb/s or lower, an implementation may optionally elect to end retransmission attempts after a late collision is detected. While operating at the speed of 1000 Mb/s, an implementation shall end retransmission attempts after a late collision is detected.

After transmission of the jam has been completed, if TransmitLinkMgmt determines that another attempt should be made, BackOff is called to schedule the next attempt to retransmit the frame.

```

function Random (low, high: integer): integer;
begin
  Random := ... {Uniformly distributed random integer r, such that low ≤ r < high}
end; {Random}

```

BackOff performs the truncated binary exponential backoff computation and then waits for the selected multiple of the slot time:

```

var maxBackOff: 2..1024; {Working variable of BackOff}
procedure BackOff;
begin
  if attempts = 1 then maxBackOff := 2
  else if attempts ≤ backOffLimit then maxBackOff := maxBackOff × 2;
  Wait(slotTime × Random(0, maxBackOff))
end; {BackOff}

```

BurstTimer is a process that does nothing unless the bursting variable is true. When bursting is true, BurstTimer increments burstCounter until the burstLimit limit is reached, whereupon BurstTimer assigns the value false to bursting:

```

process BurstTimer;
begin

```

```

cycle
  while not bursting do nothing; {Wait for a burst}
  Wait(burstLimit);
  bursting := false
end {burstMode cycle}
end; {BurstTimer}

```

The Deference process runs asynchronously to continuously compute the proper value for the variable *deferring*. In the case of half duplex burst mode, *deferring* remains true throughout the entire burst. Interpacket gap spacing may be used to lower the average data rate of a MAC at operating speeds above 1000 Mb/s in the full duplex mode, when it is necessary to adapt it to the data rate of a WAN-based Physical Layer. When interpacket stretching is enabled, *deferring* remains true throughout the entire extended interpacket gap, which includes the sum of *interPacketGap* and the interpacket extension as determined by the *BitTransmitter*:

```

process Deference;
  var realTimeCounter: integer; wasTransmitting: Boolean;
  begin
    if halfDuplex then cycle {Half duplex loop}
      while not carrierSense do nothing; {Watch for carrier to appear}
      deferring := true; {Delay start of new transmissions}
      wasTransmitting := transmitting;
      while carrierSense or transmitting do wasTransmitting := wasTransmitting or transmitting;
      if wasTransmitting then Wait(interPacketGapPart1) {Time out first part of
        interpacket gap}
      else
        begin
          realTimeCounter := interPacketGapPart1;
          repeat
            while carrierSense do realTimeCounter := interPacketGapPart1;
            Wait(1);
            realTimeCounter := realTimeCounter – 1
          until (realTimeCounter = 0)
        end;
        Wait(interPacketGapPart2); {Time out second part of
          interpacket gap}
        deferring := false; {Allow new transmissions to proceed}
        while frameWaiting do nothing {Allow waiting transmission, if any}
      end {Half duplex loop}
    else cycle {Full duplex loop}
      while not transmitting do nothing; {Wait for the start of a transmission}
      deferring := true; {Inhibit future transmissions}
      while transmitting do nothing; {Wait for the end of the current transmission}
      Wait(interPacketGap + ipgStretchSize × 8); {Time out entire interpacket
        gap and IPG extension}
      if not frameWaiting then {Don't roll over the remainder into the next frame}
        begin
          Wait(8);
          ipgStretchCount := 0
        end
      deferring := false {Don't inhibit transmission}
    end {Full duplex loop}
  end; {Deference}

```

If the `ipgStretchMode` is enabled, the Deference process continues to enforce interpacket gap for an additional number of bit times, after the completion of timing the `interPacketGap`. The additional number of bit times is reflected by the variable `ipgStretchSize`. If the variable `ipgStretchCount` is less than `ipgStretchRatio` and the next frame is ready for transmission (variable `frameWaiting` is true), the Deference process enforces interpacket gap only for the integer number of octets, as indicated by `ipgStretchSize`, and saves `ipgStretchCount` for the next frame's transmission. If the next frame is not ready for transmission (variable `frameWaiting` is false), then the Deference process initializes the `ipgStretchCount` variable to zero.

The `BitTransmitter` process runs asynchronously, transmitting bits at a rate determined by the Physical Layer's `TransmitBit` operation:

```

process BitTransmitter;
begin
  cycle {Outer loop}
    if transmitting then
      begin {Inner loop}
        extendError := false;
        if ifsStretchMode then {Calculate the counter values}
          begin
            ipgStretchSize := (ipgStretchCount + headerSize +
              frameSize + interPacketGap) div
              ipgStretchRatio; {Extension of the
              interpacket gap}
            ipgStretchCount := (ipgStretchCount + headerSize +
              frameSize + interPacketGap)
              mod ipgStretchRatio {Remainder to carry over into
              the next frame's transmission}
          end;
        PhysicalSignalEncap; {Send preamble and start of frame delimiter}
        while transmitting do
          begin
            if (currentTransmitBit > lastTransmitBit) then TransmitBit(extensionBit)
            else if extendError then TransmitBit(extensionErrorBit) {Jam in extension}
            else TransmitBit(outgoingFrame[currentTransmitBit]);
            if newCollision then StartJam else NextBit
          end;
          if bursting then
            begin
              interPacketSignal;
              if extendError then
                if transmitting then transmitting := false
                  {TransmitFrame may have been called during
                  interPacketSignal}
                else IncLargeCounter(lateCollision);
                  {Count late collisions which were missed by TransmitLinkMgmt}
                bursting := bursting and (frameWaiting or transmitting)
            end
          end {Inner loop}
        end {Outer loop}
      end; {BitTransmitter}

```

The bits transmitted to the Physical Layer can take one of four values: data zero (0), data one (1), extension-Bit (EXTEND), or extensionErrorBit (EXTEND\_ERROR). The values `extensionBit` and `extensionErrorBit` are not transmitted between the first preamble bit of a frame and the last data bit of a frame under any cir-

cumstances. The BitTransmitter calls the procedure TransmitBit with bitParam = extensionBit only when it is necessary to perform carrier extension on a frame after all of the data bits of a frame have been transmitted. The BitTransmitter calls the procedure TransmitBit with bitParam = extensionErrorBit only when it is necessary to jam during carrier extension.

```

procedure PhysicalSignalEncap;
begin
  while currentTransmitBit ≤ lastHeaderBit do
    begin
      TransmitBit(outgoingHeader[currentTransmitBit]); {Transmit header one bit at a time}
      currentTransmitBit := currentTransmitBit + 1
    end;
    if newCollision then StartJam else currentTransmitBit := 1
  end; {PhysicalSignalEncap}

```

The procedure interPacketSignal fills the interpacket interval between the frames of a burst with extensionBits. InterPacketSignal also monitors the variable collisionDetect during the interpacket interval between the frames of a burst, and will end a burst if a collision occurs during the interpacket interval. The procedural model is defined such that a MAC operating in the burstMode will emit an extraneous sequence of interPacketSize extensionBits in the event that there are no additional frames ready for transmission after interPacketSignal returns. Implementations may be able to avoid sending this extraneous sequence of extensionBits if they have access to information (such as the occupancy of a transmit queue) that is not assumed to be available to the procedural model.

```

procedure interPacketSignal;
  var interPacketCount, interPacketTotal: integer;
begin
  interPacketCount := 0;
  interPacketTotal := interPacketSpacing;
  while interPacketCount < interPacketTotal do
    begin
      if not extendError then TransmitBit(extensionBit)
      else TransmitBit(extensionErrorBit);
      interPacketCount := interPacketCount + 1;
      if collisionDetect and not extendError then
        begin
          bursting := false;
          extendError := true;
          interPacketCount := 0;
          interPacketTotal := jamSize
        end
    end
  end; {interPacketSignal}

```

```

procedure NextBit;
begin
  currentTransmitBit := currentTransmitBit + 1;
  if halfDuplex and burstStart and transmitSucceeding then {Carrier extension may be required}
    transmitting := (currentTransmitBit ≤ max(lastTransmitBit, slotTime))
  else transmitting := (currentTransmitBit ≤ lastTransmitBit)
end; {NextBit}

```

```

procedure StartJam;
begin

```

```

    extendError := currentTransmitBit > lastTransmitBit;
    currentTransmitBit := 1;
    lastTransmitBit := jamSize;
    newCollision := false
end; {StartJam}

```

BitTransmitter, upon detecting a new collision, immediately enforces it by calling StartJam to initiate the transmission of the jam. The jam should contain a sufficient number of bits of arbitrary data so that it is assured that both communicating stations detect the collision. (StartJam uses the first set of bits of the frame up to jamSize, merely to simplify this program.)

#### 4.2.9 Frame reception

The algorithms in this subclause define CSMA/CD Media Access sublayer frame reception.

The function ReceiveFrame implements the frame reception operation provided to the MAC client.

The ReceiveFrame operation is synchronous. The operation does not complete until a frame has been received. The fields of the frame are delivered via the output parameters with a status code.

The receiveDisabled status code (if layer management is implemented) indicates that the receiver is not enabled. Successful reception is indicated by the status code receiveOK. The frameTooLong error code (if layer management is implemented) indicates that the last frame received had a frameSize beyond the maximum allowable frame size. The code frameCheckError indicates that the frame received was damaged by a transmission error. The lengthError indicates that the lengthOrTypeParam value was both consistent with a length interpretation of this field (i.e., its value was less than or equal to maxValidFrame), and inconsistent with the frameSize of the received frame. The code alignmentError indicates that the frame received was damaged, and that in addition, its length was not an integer number of octets. ReceiveStatus is not mapped to any MAC client parameter by the service interface defined in 2.3.2. ReceiveStatus may be used in an implementation dependent manner.

```

function ReceiveFrame (
    var destinationParam: AddressValue;
    var sourceParam: AddressValue;
    var lengthOrTypeParam: LengthOrTypeValue;
    var dataParam: DataValue;
    var fcsParamValue: CRCValue;
    var fcsParamPresent: Bit): ReceiveStatus;
function ReceiveDataDecap: ReceiveStatus; {Nested function; see body below}
begin
    if receiveEnabled then
        repeat
            ReceiveLinkMgmt;
            ReceiveFrame := ReceiveDataDecap;
        until receiveSucceeding
    else ReceiveFrame := receiveDisabled
end; {ReceiveFrame}

```

If enabled, ReceiveFrame calls ReceiveLinkMgmt to receive the next valid frame, and then calls the internal function ReceiveDataDecap to return the frame's fields to the MAC client if the frame's address indicates that it should do so. The returned ReceiveStatus indicates the presence or absence of detected transmission errors in the frame.

```

function ReceiveDataDecap: ReceiveStatus;

```



```

‡   var status: ReceiveStatus; {Holds receive status information}
begin
‡   with incomingFrame do
‡     begin
‡       view := fields;
‡       receiveSucceeding := LayerMgmtRecognizeAddress(destinationField);
‡       if receiveSucceeding then
‡         begin {Disassemble MAC frame}
‡           destinationParam := destinationField;
‡           sourceParam := sourceField;
‡           lengthOrTypeParam := lengthOrTypeField;
‡           dataParam := RemovePad(lengthOrTypeField, dataField);
‡           fcsParamValue := fcsField;
‡           fcsParamPresent := passReceiveFCSType;
‡           exceedsMaxLength := ...; {Check to determine if received MAC frame size exceeds
‡                                     maxFrameSizeLimit.
‡                                     MAC implementations use maxFrameSizeLimit to
‡                                     determine if management counts the frame as too long.
‡                                     It is recommended that new implementations support
‡                                     maxFrameSizeLimit = maxEnvelopeFrameSize }
‡           if exceedsMaxLength then status := frameTooLong
‡           else if fcsField = CRC32(incomingFrame) and extensionOK then
‡             if validLength then status := receiveOK else status := lengthError
‡             else if excessBits = 0 or not extensionOK then status := frameCheckError
‡             else status := alignmentError;
‡             LayerMgmtReceiveCounters(status); {Update receive counters in 5.2.4.3}
‡           view := bits
‡         end {Disassemble MAC frame}
‡       end; {With incomingFrame}
‡       ReceiveDataDecap := status
‡     end; {ReceiveDataDecap}

function LayerMgmtRecognizeAddress(address: AddressValue): Boolean;
begin
  if {promiscuous receive enabled} then LayerMgmtRecognizeAddress := true;
  if address = ... {MAC station address} then LayerMgmtRecognizeAddress := true;
  if address = ... {Broadcast address} then LayerMgmtRecognizeAddress := true;
  if address = ... {One of the addresses on the multicast list and multicast reception is enabled} then
    LayerMgmtRecognizeAddress := true;
  LayerMgmtRecognizeAddress := false
end; {LayerMgmtRecognizeAddress}

```

The function RemovePad strips any padding that was generated to meet the minFrameSize constraint, if possible. When the MAC sublayer operates in the mode that enables passing of the frame check sequence field of all received MAC frames to the MAC client (passReceiveFCSType variable is true), it shall not strip the padding and it shall leave the data field of the MAC frame intact. Length checking is provided for Length interpretations of the Length/Type field. For Length/Type field values in the range between maxBasicDataSize and minTypeValue, the behavior of the RemovePad function is unspecified:

```

function RemovePad(var lengthOrTypeParam: LengthOrTypeValue; dataParam: DataValue): DataValue;
begin
  if lengthOrTypeParam ≥ minTypeValue then
    begin
      validLength := true; {Don't perform length checking for Type field interpretations}
    end
  end
end

```

```

    RemovePad := dataParam
  end
else if lengthOrTypeParam ≤ maxBasicDataSize then
  begin
    validLength := {For length interpretations of the Length/Type field, check to determine if value
                    represented by Length/Type field matches the received clientDataSize};
    if validLength and not passReceiveFCSTypeMode then
      RemovePad := {Truncate the dataParam (when present) to the value represented by the
                   lengthOrTypeParam (in octets) and return the result}
    else RemovePad := dataParam
  end
end; {RemovePad}

```

ReceiveLinkMgmt attempts repeatedly to receive the bits of a frame, discarding any fragments from collisions by comparing them to the minimum valid frame size:

```

procedure ReceiveLinkMgmt;
  begin
    repeat
      StartReceive;
      while receiving do nothing; {Wait for frame to finish arriving}
      excessBits := frameSize mod 8;
      frameSize := frameSize – excessBits; {Truncate to octet boundary}
      receiveSucceeding := receiveSucceeding and (frameSize ≥ minFrameSize)
                          {Reject collision fragments}

    until receiveSucceeding
  end; {ReceiveLinkMgmt}

procedure StartReceive;
  begin
    receiveSucceeding := true;
    receiving := true
  end; {StartReceive}

```

The BitReceiver process runs asynchronously, receiving bits from the medium at the rate determined by the Physical Layer's ReceiveBit operation, partitioning them into frames, and optionally receiving them:

```

process BitReceiver;
  var  b: PhysicalBit;
       incomingFrameSize: integer; {Count of all bits received in frame including extension}
       frameFinished: Boolean;
       enableBitReceiver: Boolean;
       currentReceiveBit: 1..frameSize; {Position of current bit in incomingFrame}

  begin
    cycle {Outer loop}
    if receiveEnabled then
      begin {Receive next frame from Physical Layer}
        currentReceiveBit := 1;
        incomingFrameSize := 0;
        frameFinished := false;
        enableBitReceiver := receiving;
        PhysicalSignalDecap; {Skip idle and extension, strip off preamble and sfd}
        if enableBitReceiver then extensionOK := true;
        while receiveDataValid and not frameFinished do

```

```

begin {Inner loop to receive the rest of an incoming frame}
  b := ReceiveBit; {Next bit from physical medium}
  incomingFrameSize := incomingFrameSize + 1;
  if b = 0 or b = 1 then {Normal case}
    if enableBitReceiver then {Append to frame}
      begin
        if incomingFrameSize > currentReceiveBit then extensionOK := false;
          {Errors in the extension get mapped to data bits on input}
        incomingFrame[currentReceiveBit] := b;
        currentReceiveBit := currentReceiveBit + 1
      end
    else if not extending then frameFinished := true; {b must be an extensionBit}
    if incomingFrameSize ≥ slotTime then extending := false
  end; {Inner loop}
  if enableBitReceiver then
    begin
      frameSize := currentReceiveBit - 1;
      receiveSucceeding := not extending;
      receiving := false
    end
  end {Enabled}
end {Outer loop}
end; {BitReceiver}

```

The bits received from the Physical Layer can take one of three values: data zero (0), data one (1), or extensionBit (EXTEND). The value extensionBit will not occur between the first preamble bit of a frame and the last data bit of a frame in normal circumstances. Extension bits are counted by the BitReceiver but are not appended to the incoming frame. The BitReceiver checks whether the bit received from the Physical Layer is a data bit or an extensionBit before appending it to the incoming frame. Thus, the array of bits in incomingFrame will only contain data bits. The underlying Reconciliation Sublayer (RS) maps incoming EXTEND\_ERROR bits to normal data bits. Thus, the reception of additional data bits after the frame extension has started is an indication that the frame should be discarded.

```

procedure PhysicalSignalDecap;
begin
  {Receive one bit at a time from physical medium until a valid sfd is detected, discard bits and return}
end; {PhysicalSignalDecap}

```

The process SetExtending controls the extending variable, which determines whether a received frame must be at least slotTime bits in length or merely minFrameSize bits in length to be considered valid by the BitReceiver. SetExtending sets the extending variable to true whenever receiveDataValid is de-asserted, while in half duplex mode at an operating speed of 1000 Mb/s:

```

process SetExtending;
begin
  cycle {Loop forever}
    while receiveDataValid do nothing;
    extending := extend and halfDuplex
  end {Loop}
end; {SetExtending}

```

#### 4.2.10 Common procedures

The function CRC32 is used by both the transmit and receive algorithms to generate a 32-bit CRC value:

```
function CRC32(f: Frame): CRCValue;  
begin  
    CRC32 := {The 32-bit CRC for the entire frame as defined in 3.2.9, excluding the FCS field (if present)}  
end; {CRC32}
```

Purely to enhance readability, the following procedure is also defined:

```
procedure nothing; begin end;
```

The idle state of a process (that is, while waiting for some event) is cast as repeated calls on this procedure.

## 4.3 Interfaces to/from adjacent layers

### 4.3.1 Overview

The purpose of this clause is to provide precise definitions of the interfaces between the architectural layers defined in Clause 1 in compliance with the Media Access Service Specification given in Clause 2. In addition, the services required from the physical medium are defined.

The notation used here is the Pascal language, in keeping with the procedural nature of the precise MAC sublayer specification (see 4.2). Each interface is described as a set of procedures or shared variables, or both, that collectively provide the only valid interactions between layers. The accompanying text describes the meaning of each procedure or variable and points out any implicit interactions among them.

Note that the description of the interfaces in Pascal is a notational technique, and in no way implies that they can or should be implemented in software. This point is discussed more fully in 4.2, that provides complete Pascal declarations for the data types used in the remainder of this clause. Note also that the synchronous (one frame at a time) nature of the frame transmission and reception operations is a property of the architectural interface between the MAC client and MAC sublayers, and need not be reflected in the implementation interface between a station and its sublayer.

### 4.3.2 MAC service

The services provided to the MAC client by the MAC sublayer are transmission and reception of MAC frames using service primitives MA\_DATA.request and MA\_DATA.indication, as defined in Clause 2. For historical reasons the MAC sublayer definitions use two functions, TransmitFrame and ReceiveFrame, defined in 4.2.8 and 4.2.9. The relationship between these two functions and the service primitives is defined by the MAC client state diagrams in 4.3.2.1 and 4.3.2.2.

#### 4.3.2.1 MAC client transmit interface state diagram

##### 4.3.2.1.1 Variables

data

The value of mac\_service\_data\_unit excluding the first two octets (Length/Type field).

destination\_address

The Destination Address field parsed from the client request.

fcsPresent

Indicates whether the MA\_DATA.request service primitive contained the frame\_check\_sequence field.

frame\_check\_sequence

The fcs field parsed from the client request.

lengthOrType

The value of the first two octets at the start of the mac\_service\_data\_unit.

mac\_service\_data\_unit

The concatenation of the lengthOrType field and the data field parsed from the client request.

source\_address

The Source Address field parsed from the client request.

TransmitStatus

Indicates the status of the transmitted MAC frame. See 4.2.8.

#### 4.3.2.1.2 Functions

TransmitFrame

The MAC sublayer function invoked to transmit a MAC frame with the specified parameters. See 4.2.8.

#### 4.3.2.1.3 Messages

MA\_DATA.request

The service primitive used to convey a MAC frame to be transmitted from the MAC client. See 2.3.1.

#### 4.3.2.1.4 MAC client transmit interface state diagram

Figure 4–6 specifies the behavior of the transmit interface from the MAC client.

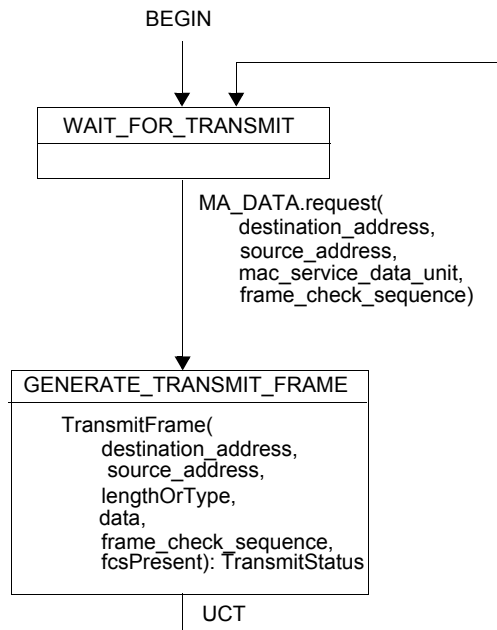


Figure 4–6— MAC client transmit interface state diagram

#### 4.3.2.2 MAC client receive interface state diagram

##### 4.3.2.2.1 Variables

destination\_address

The Destination Address field parsed from the received MAC frame.

- source\_address  
The Source Address field parsed from the received MAC frame.
- lengthOrType  
The lengthOrType field parsed from the received MAC frame.
- data  
The data payload field parsed from the received MAC frame.
- fcsPresent  
A Boolean set by the MAC sublayer.
- ReceiveStatus  
Indicates the status of the received MAC frame.
- mac\_service\_data\_unit  
The concatenation of the lengthOrType field and the data field parsed from the received MAC frame.
- frame\_check\_sequence  
The fcs field parsed from the received MAC frame.

**4.3.2.2.2 Functions**

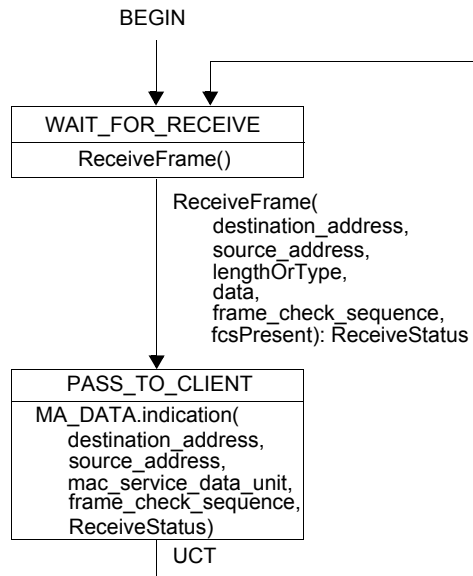
- ReceiveFrame  
The MAC sublayer function invoked to accept an incoming MAC frame with the specified parameters. See 4.2.9.

**4.3.2.2.3 Messages**

- MA\_DATA.indication  
The service primitive used to transfer an incoming MAC frame to the MAC client with the specified parameters. See 2.3.2.

**4.3.2.2.4 MAC client receive interface state diagram**

Figure 4–7 specifies the behavior of the receive interface to the MAC client.



**Figure 4–7—MAC client receive interface state diagram**

### 4.3.3 Services required from the Physical Layer

The interface through which the CSMA/CD MAC sublayer uses the facilities of the Physical Layer consists of a function, a pair of procedures and four Boolean variables:

**Table 4–1—Physical Layer interface**

Function	Procedures	Variables
ReceiveBit	TransmitBit Wait	collisionDetect carrierSense receiveDataValid transmitting

During transmission, the contents of an outgoing frame are passed from the MAC sublayer to the Physical Layer by way of repeated use of the TransmitBit operation:

*procedure* TransmitBit (bitParam: PhysicalBit);

Each invocation of TransmitBit passes one new bit of the outgoing frame to the Physical Layer. The TransmitBit operation is synchronous. The duration of the operation is the entire transmission of the bit. The operation completes, when the Physical Layer is ready to accept the next bit and it transfers control to the MAC sublayer.

The overall event of data being transmitted is signaled to the Physical Layer by way of the variable transmitting:

*var* transmitting: Boolean;

Before sending the first bit of a frame, the MAC sublayer sets transmitting to true, to inform the Physical Media Access that a stream of bits will be presented via the TransmitBit operation. After the last bit of the frame has been presented, the MAC sublayer sets transmitting to false to indicate the end of the frame.

The presence of a collision in the physical medium is signaled to the MAC sublayer by the variable collisionDetect:

*var* collisionDetect: Boolean;

The collisionDetect signal remains true during the duration of the collision.

NOTE—In full duplex mode, collision indications may still be generated by the Physical Layer; however, they are ignored by the full duplex MAC.

The collisionDetect signal is generated only during transmission and is never true at any other time; in particular, it cannot be used during frame reception to detect collisions between overlapping transmissions from two or more other stations.

During reception, the contents of an incoming frame are retrieved from the Physical Layer by the MAC sublayer via repeated use of the ReceiveBit operation:

*function* ReceiveBit: PhysicalBit;

Each invocation of ReceiveBit retrieves one new bit of the incoming frame from the Physical Layer. The ReceiveBit operation is synchronous. Its duration is the entire reception of a single bit. Upon receiving a bit, the MAC sublayer shall immediately request the next bit until all bits of the frame have been received. (See 4.2 for details.)

The overall event of data being received is signaled to the MAC sublayer by the variable `receiveDataValid`:

```
var receiveDataValid: Boolean;
```

When the Physical Layer sets `receiveDataValid` to true, the MAC sublayer shall immediately begin retrieving the incoming bits by the `ReceiveBit` operation. When `receiveDataValid` subsequently becomes false, the MAC sublayer can begin processing the received bits as a completed frame. If an invocation of `ReceiveBit` is pending when `receiveDataValid` becomes false, `ReceiveBit` returns an undefined value, which should be discarded by the MAC sublayer. (See 4.2 for details.)

NOTE—When a burst of frames is received in half duplex mode at an operating speed of 1000 Mb/s, the variable `receiveDataValid` will remain true throughout the burst. Furthermore, the variable `receiveDataValid` remains true throughout the extension field. In these respects, the behavior of the variable `receiveDataValid` is different from the underlying GMII signal `RX_DV`, from which it may be derived. See 35.2.1.7.

The overall event of activity on the physical medium is signaled to the MAC sublayer by the variable `carrierSense`:

```
var carrierSense: Boolean;
```

In half duplex mode, the MAC sublayer shall monitor the value of `carrierSense` to defer its own transmissions when the medium is busy. The Physical Layer sets `carrierSense` to true immediately upon detection of activity on the physical medium. After the activity on the physical medium ceases, `carrierSense` is set to false. Note that the true/false transitions of `carrierSense` are not defined to be precisely synchronized with the beginning and the end of the frame, but may precede the beginning and lag the end, respectively. (See 4.2 for details.) In full duplex mode, `carrierSense` is undefined.

The Physical Layer also provides the procedure `Wait`:

```
procedure Wait (bitTimes: integer);
```

This procedure waits for the specified number of bit times. This allows the MAC sublayer to measure time intervals in units of the (physical-medium-dependent) bit time.

Another important property of the Physical Layer, which is an implicit part of the interface presented to the MAC sublayer, is the round-trip propagation time of the physical medium. Its value represents the maximum time required for a signal to propagate from one end of the network to the other, and for a collision to propagate back. The round-trip propagation time is primarily (but not entirely) a function of the physical size of the network. The round-trip propagation time of the Physical Layer is defined in 4.4 for a selection of physical media.

## 4.4 Specific implementations

### 4.4.1 Compatibility overview

To provide total compatibility at all levels of the standard, it is required that each network component implementing the CSMA/CD MAC sublayer procedure adheres rigidly to these specifications. The information provided in 4.4.2 provides design parameters for specific implementations of this access method. Variations from these values result in a system implementation that violates the standard.

A DTE shall be capable of operating in half duplex mode, full duplex mode, or both. In any given instantiation of a network conforming to this standard, all stations shall be configured to use the same mode of operation, either half duplex or full duplex.



All DTEs connected to a repeater or a mixing segment shall be configured to use the half duplex mode of operation. When a pair of DTEs are connected to each other with a link segment, both devices shall be configured to use the same mode of operation, either half duplex or full duplex.

#### 4.4.2 MAC parameters

The parameter values shown in Table 4–2 shall be used for their corresponding MAC data rate.

**Table 4–2—MAC parameters**

Parameters	MAC data rate		
	Up to and including 100 Mb/s	1 Gb/s	10 Gb/s
slotTime	512 bit times	4096 bit times	not applicable
interPacketGap <sup>a</sup>	96 bits	96 bits	96 bits
attemptLimit	16	16	not applicable
backoffLimit	10	10	not applicable
jamSize	32 bits	32 bits	not applicable
maxBasicFrameSize	1518 octets	1518 octets	1518 octets
maxEnvelopeFrameSize	2000 octets	2000 octets	2000 octets
minFrameSize	512 bits (64 octets)	512 bits (64 octets)	512 bits (64 octets)
burstLimit	not applicable	65 536 bits	not applicable
ipgStretchRatio	not applicable	not applicable	104 bits

<sup>a</sup>References to interFrameGap or interFrameSpacing in other clauses (e.g., 13, 35, and 42) shall be interpreted as interPacketGap

NOTE 1—For 10 Mb/s operation, the spacing between two successive non-colliding packets, from start of idle at the end of the first packet to start of Preamble of the subsequent packet, can have a minimum value of 47 BT (bit times), at the AUI receive line of the DTE. This interPacketGap shrinkage is caused by variable network delays, added preamble bits, and clock skew.

NOTE 2—For 1BASE-5operation, see also DTE Deference Delay in 12.9.2.

NOTE 3—For 1 Gb/s operation, the spacing between two non-colliding packets, from the last bit of the FCS field of the first packet to the first bit of the Preamble of the second packet, can have a minimum value of 64 BT (bit times), as measured at the GMII receive signals at the DTE. This interPacketGap shrinkage may be caused by variable network delays, added preamble bits, and clock tolerances.

NOTE 4—For 10 Gb/s operation, the spacing between two packets, from the last bit of the FCS field of the first packet to the first bit of the Preamble of the second packet, can have a minimum value of 40 BT (bit times), as measured at the XGMII receive signals at the DTE. This interPacketGap shrinkage may be caused by variable network delays and clock tolerances.

NOTE 5—For 10 Gb/s operation, the value of ipgStretchRatio of 104 bits adapts the average data rate of the MAC sublayer to SONET/SDH STS-192 data rate (with frame granularity), for WAN-compatible applications of this standard.

NOTE 6—For 10 Mb/s half-duplex operation, the use of envelope frames is not recommended for use with repeaters, as described in Clause 9, as a result of possible frame corruption due to clock skew.

**WARNING**

Any deviation from the above specified values may affect proper operation of the network.

**4.4.3 Configuration guidelines**

The operational mode of the MAC may be determined either by the Auto-Negotiation functions specified in Clause 28 and Clause 37, or through manual configuration. When manual configuration is used, the devices on both ends of a link segment must be configured to matching modes to ensure proper operation. When Auto-Negotiation is used, the MAC must be configured to the mode determined by Auto-Negotiation before assuming normal operation.

NOTE—Improper configuration of duplex modes may result in improper network behavior.

## 5. Layer Management

All parts of Clause 5, except for 5.2.4 and its subclauses, are deprecated by Clause 30.

### 5.1 Introduction

This clause provides the Layer Management specification for DTEs based on the CSMA/CD access method. It defines facilities comprised of a set of statistics and actions needed to provide Layer Management services. The information in this clause should be used in conjunction with the Procedural Model defined in 4.2.7–4.2.10. The Procedural Model provides a formal description of the relationship between the CSMA/CD Layer Entities and the Layer Management facilities.

This Layer Management specification has been developed in accordance with the OSI management architecture as specified in the ISO Management Framework document, ISO/IEC 7498-4:1989. It is independent of any particular management application or management protocol.

The management facilities defined in this standard may be accessed both locally and remotely. Thus, the Layer Management specification provides facilities that can be accessed from within a station or can be accessed remotely by means of a peer management protocol operating between application entities. The encoding appropriate for use with ISO CMIP and ISO/IEC 15802-2:1995 protocols can be found in Annex H.

In CSMA/CD no peer management facilities are necessary for initiating or terminating normal protocol operations or for handling abnormal protocol conditions. The monitoring of these activities is done by the carrier sense and collision detection mechanisms. Since these activities are necessary for normal operation of the protocol, they are not considered to be a function of Layer Management and are therefore not discussed in this clause.

Implementation of DTE Management is not a requirement for conformance to Clause 4 and Clause 7.

#### 5.1.1 Systems Management overview

Within the ISO/IEC Open Systems Interconnection (OSI) architecture, the need to handle the special problems of initializing, terminating, and monitoring ongoing activities and assisting in their harmonious operations, as well as handling abnormal conditions, is recognized. These needs are collectively addressed by the systems management component of the OSI architecture.

A Management Protocol is required for the exchange of information between systems on a network. This Layer Management clause is independent of any particular Management Protocol.

This Layer Management clause, in conjunction with the Layer Management standards of other layers, provides the means to perform various management functions. Layer Management collects information needed from the MAC and Physical Layers. It also provides a means to exercise control over those layers.

The relationship between the various management entities and the layer entities according to the ISO model is shown in Figure 19–1.

#### 5.1.2 Layer Management model

The Layer Management facilities provided by the CSMA/CD MAC and Physical Layer management definitions provide the ability to manipulate management counters and initiate actions within the layers.

The managed objects within this standard are defined as sets of attributes, actions, notifications, and behaviors in accordance with IEEE Std 802-2001 and ISO/IEC International Standards for network management.

The precise semantics of the relationship between the CSMA/CD Layer Entities and the Layer Management facilities are defined in 4.2.7–4.2.10 and in 5.2.4.

### **5.1.3 Packages**

This standard and ISO/IEC guidelines make provision for grouping attributes, operations and notifications in implementation groups or “packages” within each managed object class. DTE Management has two packages that are required for management at the minimum conformance configuration. The basic package is also useful for system configurations that wish to implement MAU Management without DTE Management. The packages for DTE Management are specified in Table 1.

### **5.1.4 Conformance requirements**

Implementation of both the basic and the mandatory package of the MAC entity are the minimum requirements for claiming conformance to DTE Management.

## **5.2 Management facilities**

### **5.2.1 Introduction**

This subclause of the standard defines the Layer Management facilities for the ISO/IEC 8802-3 CSMA/CD MAC and Physical Layers. The intent of this subclause is to furnish a management specification that can be used by the wide variety of different DTE devices that may be attached to a network specified by this standard. Thus, a comprehensive list of management facilities is provided.

The improper use of some of the facilities described in this subclause may cause serious disruption of the network. In accordance with ISO management architecture, any necessary security provisions should be provided by the Agent in the Local System Environment. This can be in the form of specific security features or in the form of security features provided by the peer communication facilities.

All counters defined in this specification are assumed to be wraparound counters. Wraparound counters are those that automatically go from their maximum value (or final value) to zero and continue to operate. These unsigned counters do not provide for any explicit means to return them to their minimum (zero), i.e., reset. Because of their nature, wraparound counters should be read frequently enough to avoid loss of information.

### **5.2.2 DTE MAC Sublayer Management facilities**

This subclause defines the Layer Management facilities specific to the MAC sublayer Managed Object Class. Note that with regard to reception-related error statistics, a hierarchical order has been established such that when multiple error statuses can be associated with one frame, only one status is returned to the LLC. This hierarchy in descending order is as follows:

frameTooLong

alignmentError

frameCheckError

lengthError

The counters are primarily incremented based on the status returned to the LLC, and therefore the hierarchical order of the counters is determined by the order of the status. Frame fragments are not included in any of the statistics unless otherwise stated. In implementing any of the specified actions, receptions and transmissions that are in progress are completed before the action takes effect.

**Table 5-1—Packages**

			Excessive Deferral Package (Optional)	Array Package (Optional)	Optional Package (Optional)	Recommended Package (Optional)	Mandatory Package (Mandatory)	Basic Package (Mandatory)
<b>oMAC-entity</b> managed object class								
aMACID	ATTRIBUTE	GET	X					
aFramesTransmittedOK	ATTRIBUTE	GET		X				
aSingleCollisionFrames	ATTRIBUTE	GET		X				
aMultipleCollisionFrames	ATTRIBUTE	GET		X				
aFramesReceivedOK	ATTRIBUTE	GET		X				
aFrameCheckSequenceErrors	ATTRIBUTE	GET		X				
aAlignmentErrors	ATTRIBUTE	GET		X				
acInitializeMAC	ACTION		X					
aOctetsTransmittedOK	ATTRIBUTE	GET			X			
aFramesWithDeferredXmissions	ATTRIBUTE	GET			X			
aLateCollisions	ATTRIBUTE	GET			X			
aFramesAbortedDueToXSColls	ATTRIBUTE	GET			X			
aFramesLostDueToIntMACXmitError	ATTRIBUTE	GET			X			
aCarrierSenseErrors	ATTRIBUTE	GET			X			
aOctetsReceivedOK	ATTRIBUTE	GET			X			
aFramesLostDueToIntMACRevError	ATTRIBUTE	GET			X			
aPromiscuousStatus	ATTRIBUTE	GET-SET			X			
aReadMulticastAddressList	ATTRIBUTE	GET			X			
acAddGroupAddress	ACTION				X			
acDeleteGroupAddress	ACTION				X			
aMulticastFramesXmittedOK	ATTRIBUTE	GET			X			
aBroadcastFramesXmittedOK	ATTRIBUTE	GET			X			
aFramesWithExcessiveDeferral	ATTRIBUTE	GET					X	
aMulticastFramesReceivedOK	ATTRIBUTE	GET			X			
aBroadcastFramesReceivedOK	ATTRIBUTE	GET			X			
aInRangeLengthErrors	ATTRIBUTE	GET			X			
aOutOfRangeLengthField	ATTRIBUTE	GET			X			
aFrameTooLongErrors	ATTRIBUTE	GET			X			
aMACEnableStatus	ATTRIBUTE	GET-SET			X			
aTransmitEnableStatus	ATTRIBUTE	GET-SET			X			
aMulticastReceiveStatus	ATTRIBUTE	GET-SET			X			
aReadWriteMACAddress	ATTRIBUTE	GET-SET			X			
acExecuteSelfTest	ACTION				X			
aCollisionFrames	ATTRIBUTE	GET					X	
<b>oResourceTypeID</b> managed object class								
aResourceTypeIDName	ATTRIBUTE	GET	X					
aResourceInfo	ATTRIBUTE	GET	X					
<b>oPHY-entity</b> managed object class								
aPHYID	ATTRIBUTE	GET			X			
aSQETestErrors	ATTRIBUTE	GET			X			

### 5.2.2.1 DTE MAC sublayer attributes

#### 5.2.2.1.1 aMACID

ATTRIBUTE

APPROPRIATE SYNTAX:

INTEGER

BEHAVIOUR DEFINED AS:

The value of aMACID is assigned so as to uniquely identify a MAC among the subordinate managed objects of the containing object.

#### 5.2.2.1.2 aFramesTransmittedOK

ATTRIBUTE

APPROPRIATE SYNTAX:

Generalized nonresetable counter. This counter has a maximum increment rate of 16 000 counts per second.

BEHAVIOUR DEFINED AS:

A count of frames that are successfully transmitted. This counter is incremented when the TransmitStatus is reported as transmitOK. The actual update occurs in the LayerMgmtTransmitCounters procedure (5.2.4.2).

#### 5.2.2.1.3 aSingleCollisionFrames

ATTRIBUTE

APPROPRIATE SYNTAX:

Generalized nonresetable counter. This counter has a maximum increment rate of 13 000 counts per second.

BEHAVIOUR DEFINED AS:

A count of frames that are involved in a single collision and are subsequently transmitted successfully. This counter is incremented when the result of a transmission is reported as transmitOK and the attempt value is 2. The actual update occurs in the LayerMgmtTransmitCounters procedure (5.2.4.2).

#### 5.2.2.1.4 aMultipleCollisionFrames

ATTRIBUTE

APPROPRIATE SYNTAX:

Generalized nonresetable counter. This counter has a maximum increment rate of 11 000 counts per second.

BEHAVIOUR DEFINED AS:

A count of frames that are involved in more than one collision and are subsequently transmitted successfully. This counter is incremented when the TransmitStatus is reported as transmitOK and the value of the attempts variable is greater than 2 and less or equal to attemptLimit. The actual update occurs in the LayerMgmtTransmitCounters procedure (5.2.4.2).

#### 5.2.2.1.5 aFramesReceivedOK

ATTRIBUTE

APPROPRIATE SYNTAX:

Generalized nonresetable counter. This counter has a maximum increment rate of 16 000 counts per second.

BEHAVIOUR DEFINED AS:

A count of frames that are successfully received (receiveOK). This does not include frames received with frame-too-long, FCS, length or alignment errors, or frames lost due to internal MAC sublayer error. This counter is incremented when the ReceiveStatus is reported as receiveOK. The actual update occurs in the LayerMgmtReceiveCounters procedure (5.2.4.3).

#### 5.2.2.1.6 aFrameCheckSequenceErrors

ATTRIBUTE

APPROPRIATE SYNTAX:

Generalized nonresetable counter. This counter has a maximum increment rate of 16 000 counts per second.

BEHAVIOUR DEFINED AS:

A count of frames that are an integral number of octets in length and do not pass the FCS check. This counter is incremented when the ReceiveStatus is reported as frameCheckError. The actual update occurs in the LayerMgmtReceiveCounters procedure (5.2.4.3).

#### 5.2.2.1.7 aAlignmentErrors

ATTRIBUTE

APPROPRIATE SYNTAX:

Generalized nonresetable counter. This counter has a maximum increment rate of 16 000 counts per second.

BEHAVIOUR DEFINED AS:

A count of frames that are not an integral number of octets in length and do not pass the FCS check. This counter is incremented when the ReceiveStatus is reported as alignmentError. The actual update occurs in the LayerMgmtReceiveCounters procedure (5.2.4.3).

#### 5.2.2.1.8 aOctetsTransmittedOK

ATTRIBUTE

APPROPRIATE SYNTAX:

Generalized nonresetable counter. This counter has a maximum increment rate of 1 230 000 counts per second.

BEHAVIOUR DEFINED AS:

A count of data and padding octets of frames that are successfully transmitted. This counter is incremented when the TransmitStatus is reported as transmitOK. The actual update occurs in the LayerMgmtTransmitCounters procedure (5.2.4.2).

#### 5.2.2.1.9 aFramesWithDeferredXmissions

ATTRIBUTE

APPROPRIATE SYNTAX:

Generalized nonresetable counter. This counter has a maximum increment rate of 13 000 counts per second.

BEHAVIOUR DEFINED AS:

A count of frames whose transmission was delayed on its first attempt because the medium was busy. This counter is incremented when the boolean variable deferred has been asserted by the TransmitLinkMgmt function (4.2.8). Frames involved in any collisions are not counted. The actual update occurs in the LayerMgmtTransmitCounters procedure (5.2.4.2).

#### 5.2.2.1.10 aLateCollisions

ATTRIBUTE

APPROPRIATE SYNTAX:

Generalized nonresetable counter. This counter has a maximum increment rate of 16 000 counts per second.

BEHAVIOUR DEFINED AS:

A count of the times that a collision has been detected later than 512 bit times into the transmitted packet. A late collision is counted twice, i.e., both as a collision and as a lateCollision. This counter is incremented when the lateCollisionCount variable is nonzero. The actual update is incremented in the LayerMgmtTransmitCounters procedure (5.2.4.2).

#### 5.2.2.1.11 aFramesAbortedDueToXSColls

ATTRIBUTE

APPROPRIATE SYNTAX:

Generalized nonresetable counter. This counter has a maximum increment rate of 3255 counts per second.

BEHAVIOUR DEFINED AS:

A count of the frames that due to excessive collisions are not transmitted successfully. This counter is incremented when the value of the attempts variable equals attemptLimit during a transmission. The actual update occurs in the LayerMgmtTransmitCounters procedure (5.2.4.2).

#### 5.2.2.1.12 aFramesLostDueToIntMACXmitError

ATTRIBUTE

APPROPRIATE SYNTAX:

Generalized nonresetable counter. This counter has a maximum increment rate of 75 000 counts per second.

BEHAVIOUR DEFINED AS:

A count of frames that would otherwise be transmitted by the station, but could not be sent due to an internal MAC sublayer transmit error. If this counter is incremented, then none of the other counters in this subclause are incremented. The exact meaning and mechanism for incrementing this counter is implementation dependent.



**5.2.2.1.13 aCarrierSenseErrors**

ATTRIBUTE

APPROPRIATE SYNTAX:

Generalized nonresetable counter. This counter has a maximum increment rate of 16 000 counts per second.

BEHAVIOUR DEFINED AS:

A count of times that the carrierSense variable was not asserted or was deasserted during the transmission of a frame without collision (see 7.2.4.6). This counter is incremented when the carrierSenseFailure flag is true at the end of transmission. The actual update occurs in the LayerMgmtTransmitCounters procedure (5.2.4.2).

**5.2.2.1.14 aOctetsReceivedOK**

ATTRIBUTE

APPROPRIATE SYNTAX:

Generalized nonresetable counter. This counter has a maximum increment rate of 1 230 000 counts per second.

BEHAVIOUR DEFINED AS:

A count of data and padding octets in frames that are successfully received. This does not include octets in frames received with frame-too-long, FCS, length or alignment errors, or frames lost due to internal MAC sublayer error. This counter is incremented when the result of a reception is reported as a receiveOK status. The actual update occurs in the LayerMgmtReceiveCounters procedure (5.2.4.3).

**5.2.2.1.15 aFramesLostDueToIntMACRcvError**

ATTRIBUTE

APPROPRIATE SYNTAX:

Generalized nonresetable counter. This counter has a maximum increment rate of 16 000 counts per second.

BEHAVIOUR DEFINED AS:

A count of frames that would otherwise be received by the station, but could not be accepted due to an internal MAC sublayer receive error. If this counter is incremented, then none of the other counters in this subclause are incremented. The exact meaning and mechanism for incrementing this counter is implementation dependent.

**5.2.2.1.16 aPromiscuousStatus**

ATTRIBUTE

APPROPRIATE SYNTAX:

BOOLEAN

BEHAVIOUR DEFINED AS:

A GET operation returns the value true for promiscuous mode enabled, and false otherwise.

Frames without errors received solely because this attribute has the value true are counted as frames received correctly; frames received in this mode that do contain errors update the appropriate error counters.

A SET operation to the value true provides a means to cause the LayerMgmtRecognizeAddress function to accept frames regardless of their destination address.

A SET operation to the value false causes the MAC sublayer to return to the normal operation of carrying out address recognition procedures for station, broadcast, and multicast group addresses (LayerMgmtRecognizeAddress function).;

#### **5.2.2.1.17 aReadMulticastAddressList**

ATTRIBUTE

APPROPRIATE SYNTAX:

Sequence of MAC addresses.

BEHAVIOUR DEFINED AS:

Return the current multicast address list.;

#### **5.2.2.1.18 aMulticastFramesXmittedOK**

ATTRIBUTE

APPROPRIATE SYNTAX:

Generalized nonresetable counter. This counter has a maximum increment rate of 16 000 counts per second.

BEHAVIOUR DEFINED AS:

A count of frames that are successfully transmitted, as indicated by the status value transmitOK, to a group destination address other than broadcast. The actual update occurs in the LayerMgmtTransmitCounters procedure (5.2.4.2).

#### **5.2.2.1.19 aBroadcastFramesXmittedOK**

ATTRIBUTE

APPROPRIATE SYNTAX:

Generalized nonresetable counter. This counter has a maximum increment rate of 16 000 counts per second.

BEHAVIOUR DEFINED AS:

A count of the frames that were successfully transmitted, as indicated by the TransmitStatus transmitOK, to the broadcast address. Frames transmitted to multicast addresses are not broadcast frames and are excluded. The actual update occurs in the LayerMgmtTransmitCounters procedure (5.2.4.2).

#### **5.2.2.1.20 aFramesWithExcessiveDeferral**

ATTRIBUTE

APPROPRIATE SYNTAX:

Generalized nonresetable counter. This counter has a maximum increment rate of 412 counts per second.

BEHAVIOUR DEFINED AS:

A count of frames that deferred for an excessive period of time. This counter may only be incremented once per LLC transmission. This counter is incremented when the excessDefer flag is set. The actual update occurs in the LayerMgmtTransmitCounters procedure (5.2.4.2).

**5.2.2.1.21 aMulticastFramesReceivedOK**

ATTRIBUTE

APPROPRIATE SYNTAX:

Generalized nonresetable counter. This counter has a maximum increment rate of 16 000 counts per second.

BEHAVIOUR DEFINED AS:

A count of frames that are successfully received and are directed to an active nonbroadcast group address. This does not include frames received with frame-too-long, FCS, length, or alignment errors, or frames lost due to internal MAC sublayer error. This counter is incremented as indicated by the receiveOK status, and the value in the destinationField. The actual update occurs in the LayerMgmtReceiveCounters procedure (5.2.4.3).

**5.2.2.1.22 aBroadcastFramesReceivedOK**

ATTRIBUTE

APPROPRIATE SYNTAX:

Generalized nonresetable counter. This counter has a maximum increment rate of 16 000 counts per second.

BEHAVIOUR DEFINED AS:

A count of frames that are successfully received and are directed to the broadcast group address. This does not include frames received with frame-too-long, FCS, length, or alignment errors, or frames lost due to internal MAC sublayer error. This counter is incremented as indicated by the receiveOK status, and the value in the destinationField. The actual update occurs in the LayerMgmtReceiveCounters procedure (5.2.4.3).

**5.2.2.1.23 aInRangeLengthErrors**

ATTRIBUTE

APPROPRIATE SYNTAX:

Generalized nonresetable counter. This counter has a maximum increment rate of 16 000 counts per second.

BEHAVIOUR DEFINED AS:

A count of frames with a length field value between the minimum unpadded LLC data size and the maximum allowed LLC data size, inclusive, that does not match the number of LLC data octets received. The counter also contains frames with a length field value less than the minimum unpadded LLC data size. The actual update occurs in the LayerMgmtReceiveCounters procedure (5.2.4.3).

**5.2.2.1.24 aOutOfRangeLengthField**

ATTRIBUTE

APPROPRIATE SYNTAX:

Generalized nonresetable counter. This counter has a maximum increment rate of 16 000 counts per second.

BEHAVIOUR DEFINED AS:

A count of frames with a length field value greater than the maximum allowed LLC data size. The actual update occurs in the LayerMgmtReceiveCounters procedure (5.2.4.3).

#### 5.2.2.1.25 aFrameTooLongErrors

ATTRIBUTE

APPROPRIATE SYNTAX:

Generalized nonresetable counter. This counter has a maximum increment rate of 815 counts per second.

BEHAVIOUR DEFINED AS:

A count of frames that are received and exceed the maximum permitted frame size. This counter is incremented when the status of a frame reception is frameTooLong. The actual update occurs in the LayerMgmtReceiveCounters procedure (5.2.4.3).

#### 5.2.2.1.26 aMACEnableStatus

ATTRIBUTE

APPROPRIATE SYNTAX:

BOOLEAN

BEHAVIOUR DEFINED AS:

True if MAC sublayer is enabled, and false if disabled. This is accomplished by setting or checking the values of the receiveEnabled and transmitEnabled variables.;

Setting to true provides a means to cause the MAC sublayer to enter the normal operational state at idle. The PLS is reset by this operation (see 7.2.2.2.1). This is accomplished by setting receiveEnabled and transmitEnabled to true.

Setting to false causes the MAC sublayer to end all transmit and receive operations, leaving it in a disabled state. This is accomplished by setting receiveEnabled and transmitEnabled to false.

#### 5.2.2.1.27 aTransmitEnableStatus

ATTRIBUTE

APPROPRIATE SYNTAX:

BOOLEAN

BEHAVIOUR DEFINED AS:

True if transmission is enabled, and false otherwise. This is accomplished by setting or checking the value of the transmitEnabled variable.

Setting this to true provides a means to enable MAC sublayer frame transmission (TransmitFrame function). This is accomplished by setting transmitEnabled to true.

Setting this to false will inhibit the transmission of further frames by the MAC sublayer (TransmitFrame function). This is accomplished by setting transmitEnabled to false.

#### 5.2.2.1.28 aMulticastReceiveStatus

ATTRIBUTE

APPROPRIATE SYNTAX:

BOOLEAN

BEHAVIOUR DEFINED AS:

True if multicast receive is enabled, and false otherwise.;

Setting this to true provides a means to cause the MAC sublayer to return to the normal operation of multicast frame reception.

Setting this to false will inhibit the reception of further multicast frames by the MAC sublayer.

#### 5.2.2.1.29 aReadWriteMACAddress

ATTRIBUTE

APPROPRIATE SYNTAX:

MACAddress

BEHAVIOUR DEFINED AS:

Read the MAC station address or change the MAC station address to the one supplied (RecognizeAddress function). Note that the supplied station address shall not have the group bit set and shall not be the null address.

#### 5.2.2.1.30 aCollisionFrames

ATTRIBUTE

APPROPRIATE SYNTAX:

A SEQUENCE of 32 generalized nonresetable counters. Each counter has a maximum increment rate of 13 000 counts per second.

BEHAVIOUR DEFINED AS:

A histogram of collision activity. The indices of this array (1 to attemptLimit–1) denote the number of collisions experienced in transmitting a frame. Each element of this array contains a counter that denotes the number of frames that have experienced a specific number of collisions. When the TransmitStatus is reported as transmitOK and the value of the attempts variable equals n, then collisionFrames[n–1] counter is incremented. The elements of this array are incremented in the LayerMgmtTransmitCounters procedure (5.2.4.2).

### 5.2.2.2 DTE MAC Sublayer actions

#### 5.2.2.2.1 acInitializeMAC

ACTION

APPROPRIATE SYNTAX:

None required

BEHAVIOUR DEFINED AS:

This action provides a means to call the Initialize procedure (4.2.7.4). This action also results in the initialization of the PLS.

#### 5.2.2.2.2 acAddGroupAddress

ACTION

APPROPRIATE SYNTAX:

MACAddress

BEHAVIOUR DEFINED AS:

Add the supplied multicast group address to the address recognition filter (RecognizeAddress function).

### 5.2.2.2.3 acDeleteGroupAddress

ACTION

APPROPRIATE SYNTAX:

MACAddress

BEHAVIOUR DEFINED AS:

Delete the supplied multicast group address from the address recognition filter (RecognizeAddress function).

### 5.2.2.2.4 acExecuteSelfTest

ACTION

APPROPRIATE SYNTAX:

None required

BEHAVIOUR DEFINED AS:

Execute a self-test and report the results (success or failure). The actual mechanism employed to carry out the self-test is not defined in this standard.

## 5.2.2.3 ResourceTypeID Managed Object Class

### 5.2.2.3.1 ResourceTypeID

Implementation of this managed object in accordance with the definition contained in IEEE Std 802.1F-1993 is a conformance requirement of this standard. A single instance of the Resource Type ID managed object exists within the DTE-MAC managed object class. The managed object itself is contained in IEEE Std 802.1F-1993; therefore, only the name binding appears in this standard.

## 5.2.3 DTE Physical Sublayer Management facilities

This subclause defines the Layer Management facilities specific to the Physical Layer Signaling (PLS) sublayer Managed Object Class. The PLS is required to be within a managed CSMA/CD port of a DTE. Management of that portion of the physical sublayer whose physical containment within the DTE is optional is outside the scope of this subclause.

### 5.2.3.1 DTE Physical Sublayer attributes

#### 5.2.3.1.1 aPHYID

ATTRIBUTE

APPROPRIATE SYNTAX:

INTEGER

BEHAVIOUR DEFINED AS:

The value of aPHYID is assigned so as to uniquely identify a PHY, i.e., Physical Layer among the subordinate managed objects of system (systemID and system are defined in ISO/IEC 10165-2:1992).;

#### 5.2.3.1.2 aSQETestErrors

ATTRIBUTE

APPROPRIATE SYNTAX:

Generalized nonresetable counter. This counter has a maximum increment rate of 16 000 counts per second.

## BEHAVIOUR DEFINED AS:

A count of times that the SQE\_TEST\_ERROR was received. The SQE\_TEST\_ERROR is set in accordance with the rules for verification of the SQE detection mechanism in the PLS Carrier Sense Function (see 7.2.4.6).

**5.2.4 DTE Management procedural model**

The following model provides the descriptions for Layer Management facilities.

**5.2.4.1 Common constants and types**

The following are the common constants and types required for the Layer Management procedures:

*const*

maxDeferTime = ...;  $\{2 \times (\text{maxBasicFrameSize} \times 8), \text{ for operating speeds of 100 Mb/s and below, and } 2 \times (\text{burstLimit} + \text{maxBasicFrameSize} \times 8 + \text{headerSize}) \text{ for operating speeds greater than 100 Mb/s, in bits, error timer limit for maxDeferTime}\}$

*type*

CounterLarge = 0..maxLarge; {see footnote<sup>22</sup>}.

**5.2.4.2 Transmit variables and procedures**

The following items are specific to frame transmission:

*var*

excessDefer: Boolean; {set in process DeferTest}  
 carrierSenseFailure: Boolean; {set in process CarrierSenseTest}  
 transmitEnabled: Boolean; {set by MAC action}  
 lateCollisionError: Boolean; {set in Section 4 procedure WatchForCollision}  
 deferred: Boolean; {set in Section 4 function TransmitLinkMgmt}  
 carrierSenseTestDone: Boolean; {set in process CarrierSenseTest}  
 lateCollisionCount: 0..attemptLimit – 1; {count of late collision that is used in Clause 4  
 TransmitLinkMgmt and BitTransmitter}  
 {MAC transmit counters}  
 framesTransmittedOK: CounterLarge; {mandatory}  
 singleCollisionFrames: CounterLarge; {mandatory}  
 multipleCollisionFrames: CounterLarge; {mandatory}  
 collisionFrames: array [1..attemptLimit – 1] of CounterLarge; {recommended}  
 octetsTransmittedOK: CounterLarge; {recommended}  
 deferredTransmissions: CounterLarge; {recommended}  
 multicastFramesTransmittedOK: CounterLarge; {optional}  
 broadcastFramesTransmittedOK: CounterLarge; {optional}  
 {MAC transmit error counters}  
 lateCollision: CounterLarge; {recommended}  
 excessiveCollision: CounterLarge; {recommended}  
 carrierSenseErrors: CounterLarge; {optional}  
 excessiveDeferral: CounterLarge; {optional}  
 halfDuplex: Boolean; {Indicates the desired mode. halfDuplex is a static variable; its value does  
 not change between invocations of the Initialize procedure}

<sup>22</sup>The CounterLarge declaration is an example of how to declare a counter. This particular example produces a 32 bit counter.

Procedure `LayerMgmtTransmitCounters` is invoked from the `TransmitLinkMgmt` function and from the `BitTransmitter` process in 4.2.8 to update the transmit and transmit error counters.

```
procedure LayerMgmtTransmitCounters;  
begin  
  if halfDuplex then  
    while not carrierSenseTestDone do nothing;  
  if transmitSucceeding then  
    begin  
      IncLargeCounter(framesTransmittedOK);  
      SumLarge(octetsTransmittedOK, dataSize/8); {dataSize (in bits) is defined in 4.2.7.1}  
      if destinationField = ... {check to see if to a multicast destination}  
        then IncLargeCounter(multicastFramesTransmittedOK);  
      if destinationField = ... {check to see if to a broadcast destination}  
        then IncLargeCounter(broadcastFramesTransmittedOK);  
  
      if attempts > 1 then  
        begin {transmission delayed by collision}  
          if attempts = 2 then  
            IncLargeCounter(singleCollisionFrames) {delay by 1 collision}  
          else {attempts > 2, delayed by multiple collisions}  
            IncLargeCounter(multipleCollisionFrames)  
            IncLargeCounter(collisionFrames[attempts – 1])  
          end {delay by collision}  
        end; {transmitSucceeding}  
  
      if deferred and (attempts = 1) then  
        IncLargeCounter(deferredTransmissions);  
      if lateCollisionCount > 0 then {test if late collision detected}  
        SumLarge(lateCollision, lateCollisionCount);  
      if attempts = attemptLimit and not transmitSucceeding then  
        IncLargeCounter(excessiveCollision);  
      if carrierSenseFailure then  
        IncLargeCounter(carrierSenseErrors);  
      if excessDefer then  
        IncrementLargeCounter(excessiveDeferral)  
    end; {LayerMgmtTransmitCounters}
```

The `DeferTest` process sets the `excessDefer` flag if a transmission attempt has been deferred for a period of time longer than `maxDeferTime`.

```
process DeferTest;  
  var deferBitTimer: 0..maxDeferTime;  
begin  
  cycle  
  begin  
    deferBitTimer := 0;  
    while frameWaiting and not excessDefer do  
      begin  
        Wait(oneBitTime); {see 4.3.3}  
        if deferBitTimer = maxDeferTime then  
          excessDefer := true  
        else  
          deferBitTimer := deferBitTimer + 1  
      end
```



```

    end; {while}
    while transmitting do nothing
  end {cycle}
end; {DeferTest}

```

The CarrierSenseTest process sets the carrierSenseFailure flag if carrier sense disappears while transmitting or if it never appears during an entire transmission.

```

process CarrierSenseTest;
  var
    carrierSeen: Boolean; {Running indicator of whether or not carrierSense has been true at any
                          time during the current transmission}
    collisionSeen: Boolean; {Running indicator of whether or not the collisionDetect asserted any
                            time during the entire transmission}

  begin
    cycle {main loop}
    while not transmitting do nothing; {wait for start of transmission}
    carrierSenseFailure := false;
    carrierSeen := false;
    collisionSeen := false;
    carrierSenseTestDone := false;
    while transmitting do
      begin {inner loop}
        if carrierSense then
          carrierSeen := true;
        else
          if carrierSeen then {carrierSense disappeared before end of transmission}
            carrierSenseFailure := true;
          if collisionDetect then
            collisionSeen := true
          end; {inner loop}
        if not carrierSeen then
          carrierSenseFailure := true {carrier sense never appeared}
        else
          if collisionSeen then
            carrierSenseFailure := false;
          carrierSenseTestDone := true
        end {main loop}
      end; {CarrierSenseTest}
    end;
  end;

```

#### 5.2.4.3 Receive variables and procedures

The following items are specific to frame reception:

```

var
  receiveEnabled: Boolean; {set by MAC action}
  {MAC receive counters}
  framesReceivedOK: CounterLarge; {mandatory}
  octetsReceivedOK: CounterLarge; {recommended}

  {MAC receive error counters}
  frameCheckSequenceErrors: CounterLarge; {mandatory}
  alignmentErrors: CounterLarge; {mandatory}
  inRangeLengthErrors: CounterLarge; {optional}

```

outOfRangeLengthField: CounterLarge; {optional}  
frameTooLongErrors: CounterLarge; {optional}

{MAC receive address counters}  
multicastFramesReceivedOK: CounterLarge; {optional}  
broadcastFramesReceivedOK: CounterLarge; {optional}

Procedure LayerMgmtReceiveCounters is called by the ReceiveDataDecap function in 4.2.9 and increments the appropriate receive counters.

```
procedure LayerMgmtReceiveCounters (status: ReceiveStatus);  
begin  
  case status of  
    receiveDisabled:  
      begin  
        nothing  
      end; {receiveDisabled}  
    receiveOK:  
      begin  
        IncLargeCounter(framesReceivedOK);  
        SumLarge(octetsReceivedOK, dataSize/8); {dataSize (in bits) is defined in 4.2.7.1}  
        if destinationField = ... {check to see if to a multicast destination}  
          then IncLargeCounter(multicastFramesReceivedOK);  
        if destinationField = ... {check to see if to a broadcast destination}  
          then IncLargeCounter(broadcastFramesReceivedOK)  
        end; {receiveOK}  
    frameTooLong:  
      begin  
        IncLargeCounter(frameTooLongErrors)  
      end; {frameTooLong}  
    frameCheckError:  
      begin  
        IncLargeCounter(frameCheckSequenceErrors)  
      end; {frameCheckError}  
    alignmentError:  
      begin  
        IncLargeCounter(alignmentErrors)  
      end; {alignmentError}  
    lengthError: {Note that ReceiveStatus is never lengthError for a type interpretation of the  
                  Length/Type field. See 4.2.9}  
      begin  
        if {Length/Type field value is between the minimum MAC client data size that does not  
           require padding and maxBasicDataSize inclusive, and does not match the number of data  
           octets received} or {Length/Type field value is less than the minimum allowed MAC  
           client data size that does not require padding and the number of MAC client data octets  
           received is greater than the minimum MAC client data size that does not  
           require padding}  
          then  
            IncLargeCounter(inRangeLengthError);  
          if {Length/Type field value is greater than maxBasicDataSize} then  
            IncLargeCounter(outOfRangeLengthField)  
          end {lengthError}  
        end {case status}  
      end; {LayerMgmtReceiveCounters}
```

Function `LayerMgmtRecognizeAddress` checks if reception of certain addressing types has been enabled. Note that in Pascal, assignment to a function causes the function to return immediately.

```
function LayerMgmtRecognizeAddress(address: AddressValue): Boolean;
begin
  if {promiscuous receive enabled} then
    LayerMgmtRecognizeAddress := true;
  if address = ... {MAC station address} then
    LayerMgmtRecognizeAddress := true;
  if address = ... {broadcast address} then
    LayerMgmtRecognizeAddress := true;
  if address = ... {one of the addresses on the multicast list and multicast reception is enabled} then
    LayerMgmtRecognizeAddress := true;
  LayerMgmtRecognizeAddress := false
end; {LayerMgmtRecognizeAddress}
```

#### 5.2.4.4 Common procedures

Procedure `LayerMgmtInitialize` initializes all the variables and constants required to implement Layer Management.

```
procedure LayerMgmtInitialize;
begin
  {initialize flags for enabling/disabling transmission and reception}
  receiveEnabled := true;
  transmitEnabled := true;
  {initialize transmit flags for DeferTest and CarrierSenseTest}
  deferred := false;
  lateCollisionError := false;
  excessDefer := false;
  carrierSenseFailure := false;
  carrierSenseTestDone := false

  {Initialize all MAC sublayer management counters to zero}

end; {LayerMgmtInitialize}
```

Procedure `IncLargeCounter` increments a 32-bit wraparound counter.

```
procedure IncLargeCounter (var counter: CounterLarge);
begin
  {increment the 32-bit counter}
end; {IncLargeCounter}
```

Procedure `SumLarge` adds a value to a 32-bit wraparound counter.

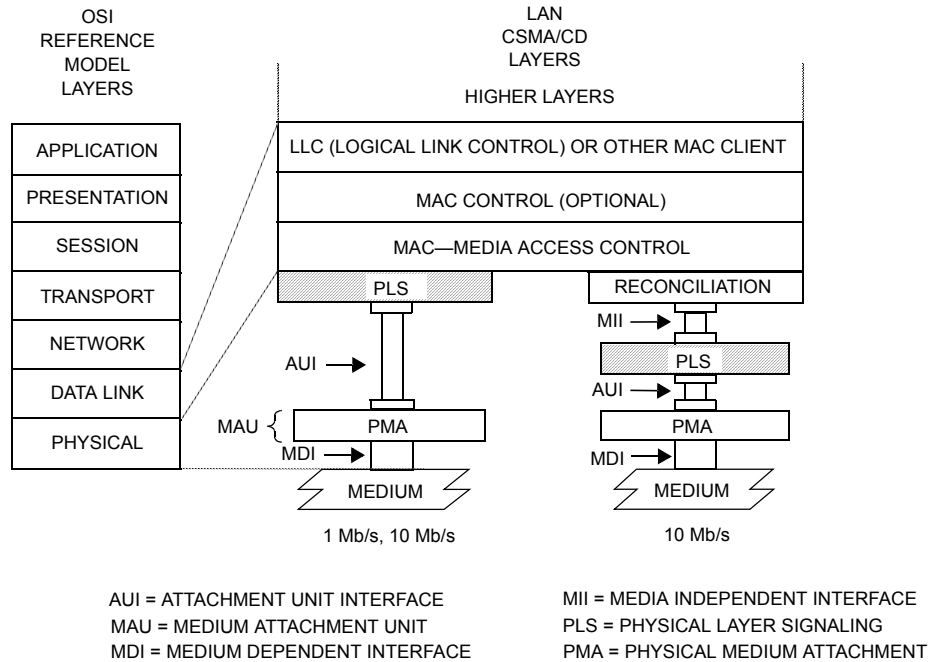
```
procedure SumLarge (
  var counter: CounterLarge;
  var offset: Integer);
begin
  {add offset to the 32-bit counter}
end; {SumLarge}
```



## 6. Physical Signaling (PLS) service specifications

### 6.1 Scope and field of application

This clause specifies the services provided by the PLS sublayer to the MAC sublayer for 1 Mb/s and 10 Mb/s implementations of this standard (see Figure 6–1). The services are described in an abstract way and do not imply any particular implementation.



**Figure 6–1—PLS service specification relationship to the ISO/IEC Open Systems Interconnection (OSI) reference model and the IEEE 802.3 CSMA/CD LAN model**

### 6.2 Overview of the service

#### 6.2.1 General description of services provided by the layer

The services provided by the PLS sublayer allow the local MAC sublayer entity to exchange data bits (PLS data\_units) with peer MAC sublayer entities.

#### 6.2.2 Model used for the service specification

The model used in this service specification is identical to that used in 1.2.2.1.

#### 6.2.3 Overview of interactions

The primitives associated with the MAC sublayer to PLS sublayer interface fall into two basic categories:

- a) Service primitives that support MAC peer-to-peer interactions.
- b) Service primitives that have local significance and support sublayer-to-sublayer interactions.

The following primitives are grouped into these two categories:

- a) Peer-to-Peer
  - PLS\_DATA.request
  - PLS\_DATA.indication
- b) Sublayer-to-Sublayer
  - PLS\_CARRIER.indication
  - PLS\_SIGNAL.indication
  - PLS\_DATA\_VALID.indication

The PLS\_DATA primitives support the transfer of data from a single MAC sublayer entity to all other peer MAC sublayer entities contained within the same LAN defined by the broadcast medium.

NOTE—In half duplex mode, all bits transferred from a MAC sublayer entity will in turn be received by the entity itself.

The PLS\_CARRIER, PLS\_DATA\_VALID, and the PLS\_SIGNAL primitives provide information needed by the local MAC sublayer entity to perform the media access functions.

## 6.2.4 Basic services and options

All of the service primitives described in this subclause are considered mandatory.

## 6.3 Detailed service specification

### 6.3.1 Peer-to-peer service primitives

#### 6.3.1.1 PLS\_DATA.request

##### 6.3.1.1.1 Function

This primitive defines the transfer of data from the MAC sublayer to the local PLS entity.

##### 6.3.1.1.2 Semantics of the service primitive

The primitive shall provide the following parameters:

PLS\_DATA.request (OUTPUT\_UNIT)

The OUTPUT\_UNIT parameter can take on one of three values: ONE, ZERO, or DATA\_COMPLETE and represent a single data bit. The DATA\_COMPLETE value signifies that the Media Access Control sublayer has no more data to output.

##### 6.3.1.1.3 When generated

This primitive is generated by the MAC sublayer to request the transmission of a single data bit on the physical medium or to stop transmission.

##### 6.3.1.1.4 Effect of receipt

The receipt of this primitive will cause the PLS entity to encode and transmit either a single data bit or to cease transmission.

### 6.3.1.2 PLS\_DATA.indication

#### 6.3.1.2.1 Function

This primitive defines the transfer of data from the PLS sublayer to the MAC sublayer.

#### 6.3.1.2.2 Semantics of the service primitive

The semantics of the service primitive are as follows:

PLS\_DATA. indicate (INPUT\_UNIT)

The INPUT\_UNIT parameter can take one of two values each representing a single bit: ONE or ZERO.

#### 6.3.1.2.3 When generated

The PLS\_DATA.indication is generated to all MAC sublayer entities in the network after a PLS\_DATA.request is issued.

NOTE—In half duplex mode, an indication is also presented to the MAC entity that issued the request.

#### 6.3.1.2.4 Effect of receipt

The effect of receipt of this primitive by the MAC sublayer is not specified in this Clause.

### 6.3.2 Sublayer-to-sublayer service primitives

#### 6.3.2.1 PLS\_CARRIER.indication

##### 6.3.2.1.1 Function

This primitive transfers the status of the activity on the physical medium from the PLS sublayer to the MAC sublayer.

##### 6.3.2.1.2 Semantics of the service primitive

The semantics of the primitive are as follows:

PLS\_CARRIER.indication (CARRIER\_STATUS)

The CARRIER\_STATUS parameter can take one of two values: CARRIER\_ON or CARRIER\_OFF. The CARRIER\_ON value indicates that the DTE Physical Layer had received an *input* message or a *signal\_quality\_error* message from the MAU. The CARRIER\_OFF value indicates that the DTE Physical Layer had received an *input\_idle* message and is not receiving an SQE *signal\_quality\_error* message from the MAU.

##### 6.3.2.1.3 When generated

The PLS\_CARRIER.indication service primitive is generated whenever CARRIER\_STATUS makes a transition from CARRIER\_ON to CARRIER\_OFF or vice versa.

##### 6.3.2.1.4 Effect of receipt

The effect of receipt of this primitive by the MAC sublayer is not specified in this Clause.

### **6.3.2.2 PLS\_SIGNAL.indication**

#### **6.3.2.2.1 Function**

This primitive transfers the status of the Physical Layer signal quality from the PLS sublayer to the MAC sublayer.

#### **6.3.2.2.2 Semantics of the service primitive**

The semantics of the service primitive are as follows:

PLS\_SIGNAL.indication (SIGNAL\_STATUS)

The SIGNAL\_STATUS parameter can take one of two values: SIGNAL\_ERROR or NO\_SIGNAL\_ERROR. The SIGNAL\_ERROR value indicates to the MAC sublayer that the PLS has received a *signal\_quality\_error* message from the MAU. The NO\_SIGNAL\_ERROR value indicates that the PLS has ceased to receive *signal\_quality\_error* messages from the MAU.

#### **6.3.2.2.3 When generated**

The PLS\_SIGNAL.indication service primitive is generated whenever SIGNAL\_STATUS makes a transition from SIGNAL\_ERROR to NO\_SIGNAL\_ERROR or vice versa.

#### **6.3.2.2.4 Effect of receipt**

The effect of receipt of this primitive by the MAC sublayer is not specified in this Clause.

### **6.3.2.3 PLS\_DATA\_VALID.indication**

#### **6.3.2.3.1 Function**

This primitive provides a facility for transferring framing information to the MAC sublayer.

#### **6.3.2.3.2 Semantics of the service primitive**

The semantics of the service primitive are as follows:

PLS\_DATA\_VALID.indication (DATA\_VALID\_STATUS)

The DATA\_VALID\_STATUS parameter can take one of two values: DATA\_VALID or DATA\_NOT\_VALID. The DATA\_VALID value indicates that the INPUT\_UNIT parameter of the PLS\_DATA.indication primitive contains valid data of an incoming frame. The DATA\_NOT\_VALID value indicates that the INPUT\_UNIT parameter of the PLS\_DATA.indication primitive does not contain valid data of an incoming frame.

#### **6.3.2.3.3 When generated**

The PLS\_DATA\_VALID.indication service primitive is generated whenever the DATA\_VALID\_STATUS parameter makes a transition from DATA\_VALID to DATA\_NOT\_VALID or vice versa.

#### **6.3.2.3.4 Effect of receipt**

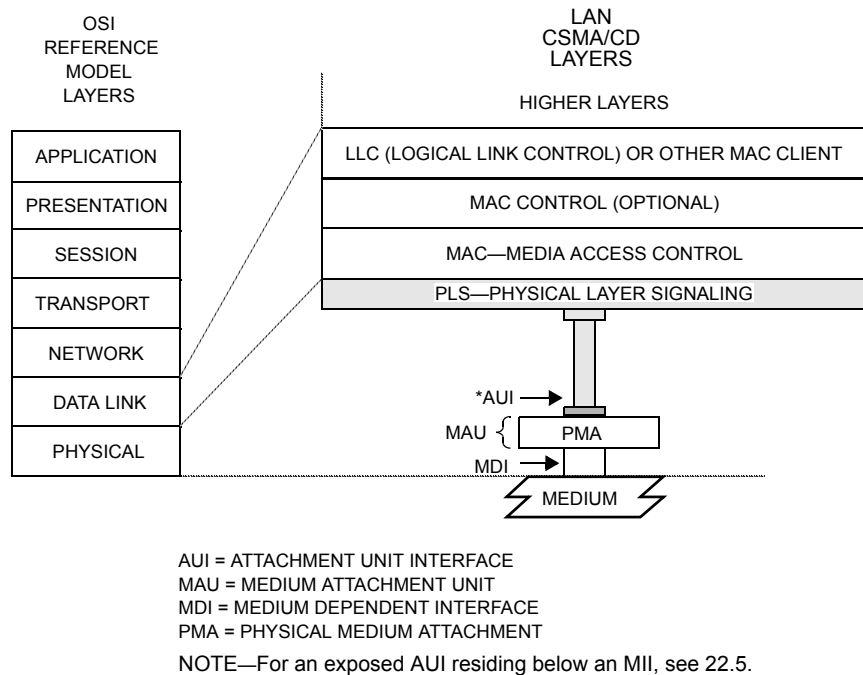
The effect of receipt of this primitive by the MAC sublayer is not specified in this Clause.



## 7. Physical Signaling (PLS) and Attachment Unit Interface (AUI) specifications

### 7.1 Scope

This clause defines the logical, electrical, and mechanical characteristics for the PLS and AUI between Data Terminal Equipment and Medium Attachment Units used in CSMA/CD local area networks. The relationship of this specification to the entire IEEE LAN standard is shown in Figure 7–1. The purpose of this interface is to provide an interconnection that is simple and inexpensive and that permits the development of simple and inexpensive MAUs.



**Figure 7–1—Physical Layer partitioning, relationship to the ISO/IEC Open Systems Interconnection (OSI) reference model**

This interface has the following characteristics:

- Capable of supporting one or more of the specified data rates.
- Capable of driving up to 50 m of cable.
- Permits the DTE to test the AUI, AUI cable, MAU, and the medium itself.
- Supports MAUs for baseband coax, baseband twisted-pair, broadband coax, and baseband fiber.

#### 7.1.1 Definitions

See 1.4.

#### 7.1.2 Summary of major concepts

- Each direction of data transfer is serviced with two (making a total of four) balanced circuits: “Data” and “Control.”

- b) The Data and Control circuits are independently self-clocked, thereby, eliminating the need for separate timing circuits. This is accomplished with encoding of all signals. The Control circuit signaling rate is nominally (but not of necessity exactly) equal to the Data circuit signaling rate.
- c) The Data circuits are used only for data transfer. No control signals associated with the interface are passed on these circuits. Likewise, the Control circuits are used only for control message transfer. No data signals associated with the interface are passed on these circuits.

### 7.1.3 Application

This standard applies to the interface used to interconnect Data Terminal Equipment (DTE) to a MAU that is not integrated as a physical part of the DTE. This interface is used to

- a) Provide the DTE with media independence for baseband coax, baseband twisted pair, broadband coax, and baseband fiber media so that identical PLS, MAC, and MAC clients may be used with any of these media.
- b) Provide for the separation, by cable of up to 50 m, of the DTE and the MAU.

### 7.1.4 Modes of operation

The AUI can operate in two different modes. All interfaces shall support the normal mode. The monitor mode is optional.

When the interface is being operated in the *normal* mode, the AUI is logically connected to the MDI. The DTE is required to follow the media access algorithms, which provide a single access procedure compatible with all LAN media, to send data over the AUI. The MAU always sends back to the DTE whatever data the MAU receives on the MDI.

When the interface is in the optional *monitor* mode, the MAUs transmitter is logically isolated from the medium. The MAU, in this mode, functions as an observer on the medium. Both the input function and the signal quality error function are operational (see the MAU state diagrams for specific details).

The PLS and AUI as specified here are able to support DTEs and MAUs operating in either half duplex or full duplex modes without change to the PLS or AUI. Full duplex MAUs do not support the monitor mode.

### 7.1.5 Allocation of function

The allocation of functions in the AUI is such that the majority of the functionality required by the interface can be provided by the DTE, leaving the MAU as simple as possible. This division of functions is based upon the recognition of the fact that since, in many cases, the MAU may be located in an inaccessible location adjacent to the physical medium, service of the MAU may often be difficult and expensive.

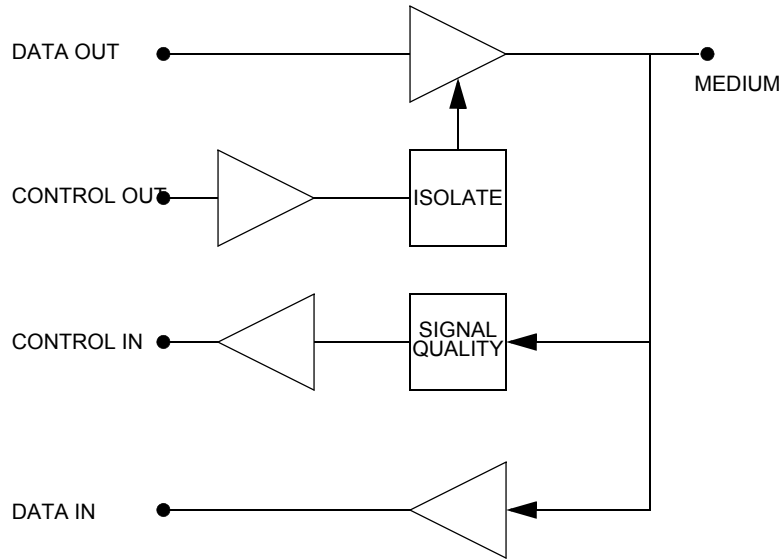
## 7.2 Functional specification

The AUI is designed to make the differences among the various media as transparent as possible to the DTE. The selection of logical control signals and the functional procedures are all designed to this end. Figure 7–2 is a reference model, a generalized MAU as seen by the DTE through the AUI.

Many of the terms used in this subclause are specific to the interface between this sublayer and the MAC sublayer. These terms are defined in the Service Specification for the PLS sublayer.

### 7.2.1 PLS–PMA (DTE–MAU) Interface protocol

The DTE and MAU communicate by means of a simple protocol across the AUI.



NOTE—The AUI (comprised of DO, DI, CO, CI circuits) is not exposed when the MAU is, optionally, part of the DTE.

**Figure 7–2—Generalized MAU model**

**7.2.1.1 PLS to PMA messages**

The following messages can be sent by PLS sublayer entities in the DTE to PMA sublayer entities in the MAU:

Message	Meaning
output	Output information
output_idle	No data to be output
normal	Cease to isolate the MAU
(Optional)	
isolate	Isolate MAU
mau_request	Request that the MAU be made available

**7.2.1.1.1 output message**

The PLS sublayer sends an *output* message to the PMA sublayer when the PLS sublayer receives an OUTPUT\_UNIT from the MAC sublayer.

The physical realization of the *output* message is a CD0 or a CD1 sent by the DTE to the MAU on the Data Out circuit. The DTE sends a CD0 if the OUTPUT\_UNIT is a ZERO or a CD1 if the OUTPUT\_UNIT is a ONE. This message is time coded—that is, once this message has been sent, the function is not completed over the AUI until one bit time later. The *output* message cannot be sent again until the bit cell being sent as a result of sending the previous *output* message is complete.

#### **7.2.1.1.2 *output\_idle* message**

The PLS sublayer sends an *output\_idle* message to the PMA sublayer at all times when the MAC sublayer is not in the process of transferring output data across the MAC to PLS interface. The *output\_idle* message is no longer sent (and the first OUTPUT\_UNIT is sent using the *output* message) as soon after the arrival of the first OUTPUT\_UNIT as the MAU can be made available for data output. The *output\_idle* message is again sent to the MAU when the DATA\_COMPLETE is received from the MAC sublayer. The detailed usage of the *output\_idle* message is shown in Figure 7–5.

The physical realization of the *output\_idle* message is IDL sent by the DTE to the MAU on the Data Out circuit.

#### **7.2.1.1.3 *normal* message**

The PLS sublayer sends a *normal* message to the PMA sublayer after it receives the PLS *start* message from the PLS Reset and Identify function. The *normal* message is also sent after receipt of RESET\_MONITOR\_MODE from the management entity. The *normal* message is sent continuously by the PLS sublayer to the MAU, unless the PLS Output function requires that the *mau\_request* message be sent to permit data output. If *mau\_request* is sent during data output, the sending of *normal* will be resumed when the PLS Output function returns to the IDLE state. The *normal* signal is reset by the SET\_MONITOR\_MODE (this reset function is described more fully by Figure 7–4).

#### **7.2.1.1.4 *isolate* message (optional)**

The PLS sublayer sends an *isolate* message to the PMA (in the MAU) whenever the PLS sublayer receives SET\_MONITOR\_MODE from the management entity. In response to the *isolate* message, the MAU causes the means employed to impress data on the physical medium to be positively prevented from affecting the medium. Since signaling and isolation techniques differ from medium to medium, the manner in which this positive isolation of the transmitting means is accomplished is specified in the appropriate MAU subclause. However, the intent of this positive isolation of the transmitter is to ensure that the MAU will not interfere with the physical medium in such a way as to affect transmissions of other stations even in the event that the means normally employed to prevent the transmitter from affecting the medium have failed to do so. The specification of positive isolation is not to be construed to preclude use of either active or passive devices to accomplish this function.

The physical realization of the *isolate* message is a CS0 signal sent by the DTE to the MAU over the Control Out circuit.

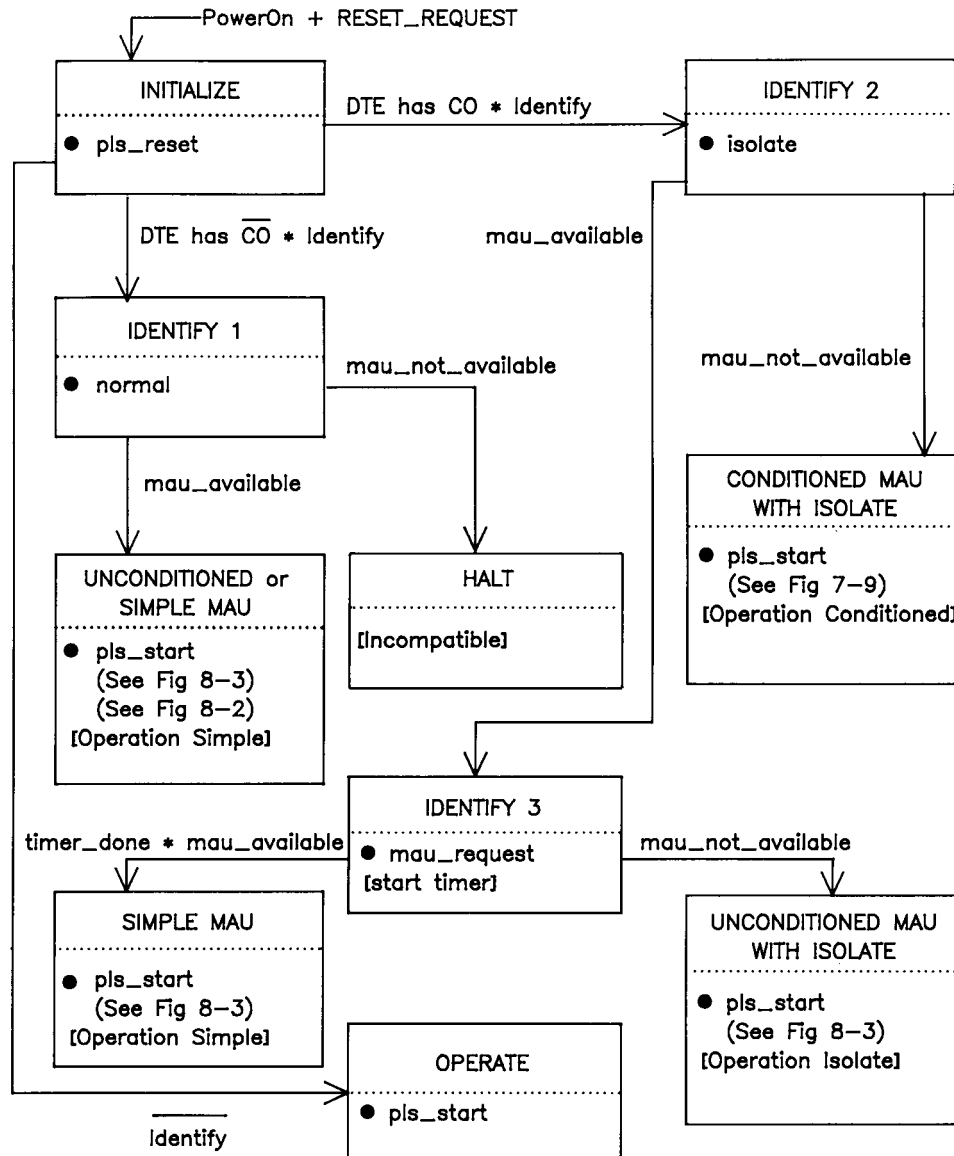
#### **7.2.1.1.5 *mau\_request* message (optional)**

The PLS sublayer sends the *mau\_request* message to the PMA sublayer if the PMA sublayer is sending the *mau\_not\_available* message and the MAC sublayer has sent the first OUTPUT\_UNIT of a new transmission. The PLS sublayer continues to send the *mau\_request* message to the MAU until the MAC sublayer sends the DATA\_COMPLETE request to the PLS sublayer across the MAC to PLS interface. See Figure 7–3, Figure 7–5, and Figure 7–9 for details.

In addition, the *mau\_request* message is used by the Reset and Identify function in the IDENTIFY 3 state to determine whether the MAU has the Isolate function.

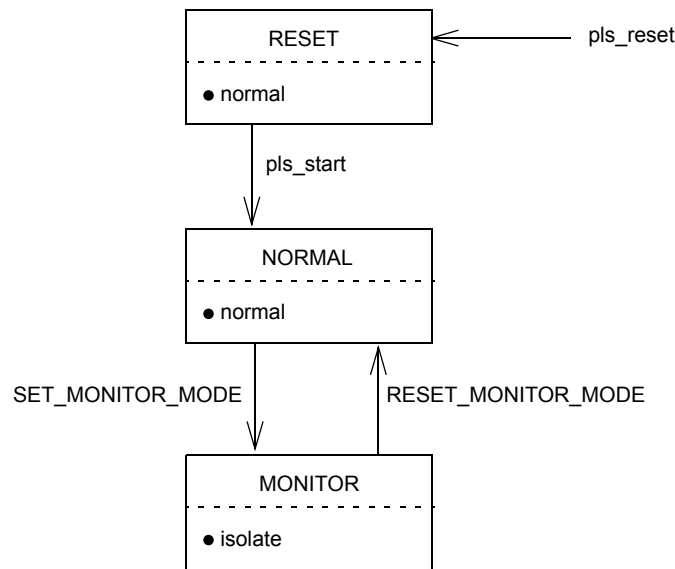
The physical realization of *mau\_request* is a CS1 sent by the DTE to the MAU on the Control Out circuit.

The physical realization of the *normal* message is the IDL signal sent by the DTE to the MAU on the Control Out circuit. In the absence of the CO circuit, MAUs implementing the Isolate function shall act as if the *normal* message is present. The CO circuit components may be absent from the DTE, AUI, or MAU.



NOTES: (1) All states may be omitted except INITIALIZE and OPERATE  
 (2) "Identify" means DTE can recognize uniquely all CI messages and the entire function has been implemented  
 (3) "Identify" with bar means DTE fails to recognize *mau\_not\_available* or has a partial implementation of the function

Figure 7-3—PLS Reset and Identify function



NOTE—Monitor State is optional

**Figure 7-4—PLS Mode function**

### 7.2.1.2 PMA to PLS interface

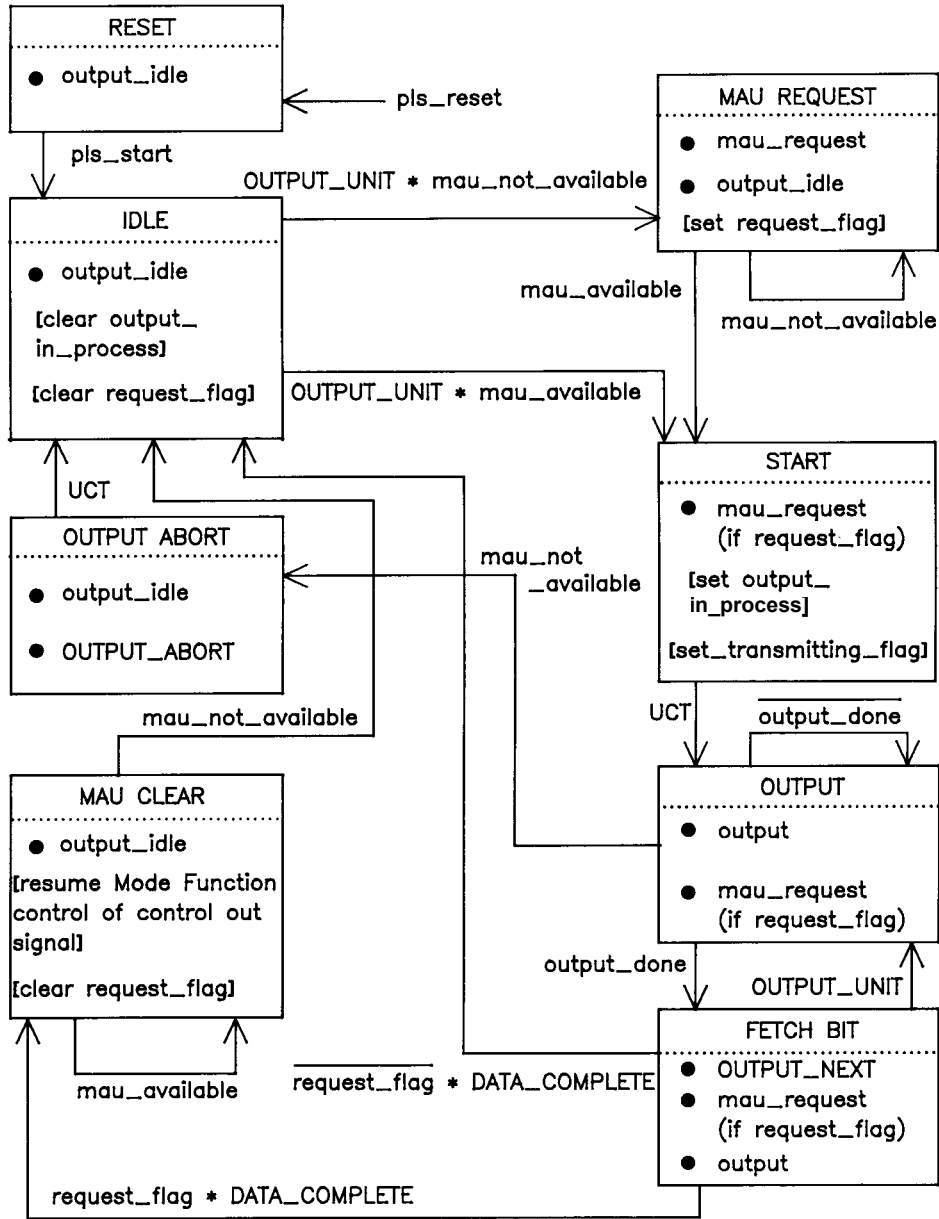
The following messages can be sent by the Physical Medium Attachment sublayer entities in the MAU to the PLS sublayer entities in the DTE:

Message	Meaning
input	Input information
input_idle	No input information
signal_quality_error	Error detected by MAU
mau_available	MAU is available for output
(Optional)	
mau_not_available	MAU is not available for output

In systems operating in full duplex mode, it is permitted, but not required, to implement the *signal\_quality\_error* message.

#### 7.2.1.2.1 input message

The PMA sublayer sends an *input* message to the PLS sublayer when the MAU has received a bit from the medium and is prepared to transfer this bit to the DTE. The actual mapping of the signals on the medium to the type of *input* message to be sent to the DTE is contained in the specifications for each specific MAU type. In general, when the *signal\_quality\_error* message is being sent by the MAU, the symmetry specifications for circuit DI are not guaranteed to be met.



NOTE: UCT = unconditional transition

Figure 7-5—PLS Output function

The physical realization of the *input* message consists of CD0 or CD1 waveforms. If the *signal\_quality\_error* message is being sent from the MAU, the input waveform is unpredictable.

NOTE—This signal is not necessarily retimed by the MAU. Consult the appropriate MAU specification for timing and jitter.

#### 7.2.1.2.2 *input\_idle* message

The PMA sublayer sends an *input\_idle* message to the PLS sublayer when the MAU does not have data to send to the DTE.

The physical realization of the *input\_idle* message is an IDL sent by the MAU to the DTE on the Data In circuit.

#### 7.2.1.2.3 *signal\_quality\_error* message

The PMA sublayer sends a *signal\_quality\_error* message to the PLS sublayer in response to any of three possible conditions. These conditions are improper signals on the medium, collision on the medium, and reception of the *output\_idle* message. They are described in the lettered paragraphs that follow. The physical realization of the *signal\_quality\_error* message is a CS0 sent by the MAU to the DTE on the Control In circuit.

In systems operating in half duplex mode, the MAU is required to assert the *signal\_quality\_error* message at the appropriate times whenever the MAU is powered, and not just when the DTE is requesting data output. In systems operating in full duplex mode, it is permitted, but not required, to implement the *signal\_quality\_error* message. See Figure 7-9, Figure 8-2, and Figure 8-3 for details.

- a) Improper Signals on the Medium. The MAU may send the *signal\_quality\_error* message at any time due to improper signals on the medium. The exact nature of these improper signals are medium-dependent. Typically, this condition might be caused by a malfunctioning MAU (for example, repeater or head-end) connected to the medium or by a break or short in the medium. See the appropriate MAU specification for specific conditions that may cause improper signals on a given medium.
- b) Collision. Collision occurs when more than one MAU is transmitting on the medium. The local MAU shall send the *signal\_quality\_error* message in every instance when it is possible for it to ascertain that more than one MAU is transmitting on the medium. The MAU shall make the best determination possible. The MAU shall not send the *signal\_quality\_error* message when it is unable to determine conclusively that more than one MAU is transmitting.
- c) *signal\_quality\_error* Message Test. The MAU sends the *signal\_quality\_error* message at the completion of the Output function. See Figure 7-9 and Clause 8 for a more complete description of this test.

#### 7.2.1.2.4 *mau\_available* message

The PMA sublayer sends the *mau\_available* message to the PLS sublayer when the MAU is available for output. The *mau\_available* message is always sent by a MAU that is always prepared to output data except when it is required to signal the *signal\_quality\_error* message. Such a MAU does not require *mau\_request* to prepare itself for data output. See Figure 7-3, Figure 7-5, and Figure 7-9 for details.

The physical realization of the *mau\_available* message is an IDL sent by the MAU to the DTE on the Control In circuit.

#### 7.2.1.2.5 *mau\_not\_available* message (optional)

The PMA sublayer sends a *mau\_not\_available* message to the PLS sublayer when the MAU is not available for output. Figure 7-5 shows the relationship of *mau\_not\_available* to the Output function.

The *mau\_not\_available* message is also used by a MAU that contains the Isolate function and does not need to be conditioned for output to signal the presence of the Isolate function during the PLS Reset function (see Figure 7-3 and Figure 8-3).



The physical realization of the *mau\_not\_available* message is a CS1 sent by the MAU to the DTE on the Control In circuit.

## 7.2.2 PLS interface to MAC and management entities

The PLS sublayer interfaces described here are for reference only. This clause specifies the services sent between the MAC sublayer and the PLS sublayer.

### 7.2.2.1 PLS–MAC interface

The following messages can be sent between PLS sublayer entities and MAC sublayer entities:

Message	Meaning
OUTPUT_UNIT	Data sent to the MAU
OUTPUT_STATUS	Response to OUTPUT_UNIT
INPUT_UNIT	Data received from the MAU
CARRIER_STATUS	Indication of channel activity
SIGNAL_STATUS	Indication of error/no error condition
DATA_VALID_STATUS	Indication of input activity

#### 7.2.2.1.1 OUTPUT\_UNIT

The MAC sublayer sends the PLS sublayer an OUTPUT\_UNIT every time the MAC sublayer has a bit to send. Once the MAC sublayer has sent an OUTPUT\_UNIT to the PLS sublayer, it may not send another OUTPUT\_UNIT until it has received an OUTPUT\_STATUS message from the PLS sublayer. The OUTPUT\_UNIT is a ONE if the MAC sublayer wants the PLS sublayer to send a CD1 to the PMA sublayer, a ZERO if a CD0 is desired, or a DATA\_COMPLETE if an IDL is desired.

#### 7.2.2.1.2 OUTPUT\_STATUS

The PLS sublayer sends the MAC sublayer OUTPUT\_STATUS in response to every OUTPUT\_UNIT received by the PLS sublayer. OUTPUT\_STATUS sent is an OUTPUT\_NEXT if the PLS sublayer is ready to accept the next OUTPUT\_UNIT from the MAC sublayer, or an OUTPUT\_ABORT if the PLS sublayer was not able to process the previous OUTPUT\_UNIT. (The purpose of OUTPUT\_STATUS is to synchronize the MAC sublayer data output with the data rate of the physical medium.)

#### 7.2.2.1.3 INPUT\_UNIT

The PLS sublayer sends the MAC sublayer an INPUT\_UNIT every time the PLS receives an *input* message from the PMA sublayer. The INPUT\_UNIT is a ONE if the PLS sublayer receives a CD1 from the PMA sublayer, a ZERO if the PLS sublayer receives a CD0 from the PMA sublayer.

#### 7.2.2.1.4 CARRIER\_STATUS

The PLS sublayer sends the MAC sublayer CARRIER\_STATUS whenever the PLS sublayer detects a change in carrier status. The PLS sublayer sends CARRIER\_ON when it receives an *input* or *signal\_quality\_error* message from the PMA and the previous CARRIER\_STATUS that the PLS sublayer sent to the MAC sublayer was CARRIER\_OFF. The PLS sublayer sends CARRIER\_OFF when it receives an *input\_idle* from the PMA sublayer, no *signal\_quality\_error* (either *mau\_available* or *mau\_not\_available*)

message and the previous CARRIER\_STATUS that the PLS sublayer sent to the MAC sublayer was CARRIER\_ON.<sup>23</sup>

### 7.2.2.1.5 SIGNAL\_STATUS

The PLS sublayer sends the MAC sublayer SIGNAL\_STATUS whenever the PLS sublayer detects a change in the signal quality (as reported by the PMA). The PLS sublayer sends SIGNAL\_ERROR when it receives a *signal\_quality\_error* message from the PMA sublayer and the previous SIGNAL\_STATUS the PLS sublayer sent was NO\_SIGNAL\_ERROR. The PLS sublayer sends NO\_SIGNAL\_ERROR when it receives no *signal\_quality\_error* (either *mau\_available* or *mau\_not\_available*) message from the PMA sublayer and the previous CARRIER\_STATUS that the PLS sent to the MAC sublayer was SIGNAL\_ERROR.<sup>24</sup>

### 7.2.2.1.6 DATA\_VALID\_STATUS

The PLS sublayer sends the MAC sublayer DATA\_VALID\_STATUS whenever the PLS sublayer detects a change in receive data status. The PLS sublayer sends DATA\_VALID when it receives an *input* message from the PMA and the previous DATA\_VALID\_STATUS that the PLS sublayer sent to the MAC sublayer was DATA\_NOT\_VALID. The PLS sublayer sends DATA\_NOT\_VALID when it is not receiving an input message from the PMA and the previous DATA\_VALID\_STATUS that the PLS sublayer sent to the MAC sublayer was DATA\_VALID.

### 7.2.2.2 PLS–management entity interface

The following messages may be sent between the PLS sublayer entities and intralayer or higher layer management entities:

Message	Meaning
RESET_REQUEST	Reset PLS to initial “Power On” state
RESET_RESPONSE	Provides operational information
MODE_CONTROL	Control operation
SQE_TEST	Signal Quality Error test results

#### 7.2.2.2.1 RESET\_REQUEST

The management entity sends the PLS sublayer RESET\_REQUEST when the PLS sublayer needs to be reset to a known state. Upon receipt of RESET\_REQUEST, the PLS sublayer resets all internal logic and restarts all functions. See Figure 7–3 for details.

<sup>23</sup> Formerly, the Carrier Sense function described in Figure 7–8 generated the CARRIER\_STATUS message described above. For the sake of consistency with common implementation practice, the variable carrierSense (see 4.3.3) is generated directly by the Carrier Sense function in recent editions of the standard.

The mapping between the CARRIER\_STATUS message and the carrierSense variable is as follows. When the carrierSense variable changes from False to True, the CARRIER\_STATUS message is sent with the parameter CARRIER\_ON. When the value of the carrierSense variable changes from True to False, the CARRIER\_STATUS message is sent with the parameter CARRIER\_OFF.

<sup>24</sup> Formerly, the PLS Error Sense function described in Figure 7–7 generated the SIGNAL\_STATUS message described above. For the sake of consistency with common implementation practice, the variable collisionDetect (see 4.3.3) is generated directly by the PLS Error Sense function in recent editions of the standard.

The mapping between the SIGNAL\_STATUS message and the collisionDetect variable is as follows. When the collisionDetect variable changes from False to True, the SIGNAL\_STATUS message is sent with the parameter SIGNAL\_ERROR. When the value of the collisionDetect variable changes from True to False, the SIGNAL\_STATUS message is sent with the parameter NO\_SIGNAL\_ERROR.

### 7.2.2.2.2 RESET\_RESPONSE

The PLS sublayer sends the management entity RESET\_RESPONSE upon completion of the Reset and Identify function (see Figure 7–3 and 7.2.4.1) whether invoked due to power on or due to a RESET\_REQUEST. Which RESET\_RESPONSE was sent is determined by the Reset and Identify function. A RESET\_RESPONSE of OPERATION SIMPLE, OPERATION ISOLATE, or OPERATION CONDITIONED is sent if the MAU is compatible with the DTE and the MAU is simple (no isolate) or if the DTE does not support Isolate even if Isolate is supported by the MAU, supports Isolate but does not require conditioning, or supports Isolate and does require conditioning to output. A RESET\_RESPONSE of INCOMPATIBLE is sent if the MAU is not compatible with the DTE (that is, the MAU requires conditioning but the DTE does not support conditioning).

### 7.2.2.2.3 MODE\_CONTROL

The management entity sends MODE\_CONTROL to the PLS sublayer to control PLS functions. MODE\_CONTROL capabilities are as follows:

Message	Meaning
ACTIVATE PHYSICAL	Supply power on circuit VP
DEACTIVATE PHYSICAL	Remove power from circuit VP
SET_MONITOR_MODE	Send Isolate to MAU
RESET_MONITOR_MODE	Send Normal to MAU

### 7.2.2.2.4 SQE\_TEST

The PLS sublayer sends SQE\_TEST to the management entity at the conclusion of each *signal\_quality\_error* test (see Output Function, 7.2.4.3). The PLS sublayer sends SQE\_TEST\_ERROR if the *signal\_quality\_error* test fails or SQE\_TEST\_OK if the *signal\_quality\_error* test passes.

In systems operating in full duplex mode, it is permitted, but not required, to implement the SQE\_TEST message.<sup>25</sup>

## 7.2.3 Frame structure

Frames transmitted on the AUI shall have the following structure:

<silence><preamble><sfd><data><etd><silence>

<sup>25</sup>Formerly, the PLS Carrier Sense function described in Figure 7–8 generated the SQE\_TEST message described above. For the sake of consistency with common implementation practice, the variable SQETestError is generated directly by the PLS Carrier Sense function in recent editions of the standard.

The mapping between the SQE\_TEST message and the PLS Carrier Sense function described in Figure 7–8 is as follows. When the transition from the state WAIT 1 to the state FAILURE occurs, the SQE\_TEST message is sent with the parameter SQE\_TEST\_ERROR. When the transition from either the state WAIT 1 or the state ABORT\_TEST to the state WAIT 2 occurs, the SIGNAL\_STATUS message is sent with the parameter NO\_SIGNAL\_ERROR.

The frame elements shall have the following characteristics:

Element	Characteristics
<silence>	= no transitions
<preamble>	= alternating (CD1) and (CD0)   56 bit times (ending in CD0)
<sfid>	= (CD1)(CD0)(CD1)(CD0)(CD1)(CD0)(CD1)(CD1)
<data>	= 8 × N instances of CD0 or CD1
<etd>	= IDL

### 7.2.3.1 Silence

The <silence> delimiter provides an observation window for an unspecified period of time during which no transitions occur on the AUI. The minimum length of this period is specified by the access procedure.

### 7.2.3.2 Preamble

The <preamble> delimiter begins a frame transmission and provides a signal for receiver synchronization. The signal shall be an alternating pattern of (CD1) and (CD0). This pattern shall be transmitted on the Data Out circuit by the DTE to the MAU for a minimum of 56 bit times at the beginning of each frame. The last bit of the preamble (that is, the final bit of preamble before the start of frame delimiter) shall be a CD0.

The DTE is required to supply at least 56 bits of preamble in order to satisfy system requirements. System components consume preamble bits in order to perform their functions. The number of preamble bits sourced ensures an adequate number of bits are provided to each system component to correctly implement its function.

### 7.2.3.3 Start of Frame Delimiter (SFD)

The <sfid> indicates the start of a frame, and follows the preamble. The <sfid> element of a frame shall be

(CD1)(CD0)(CD1)(CD0)(CD1)(CD0)(CD1)(CD1)

### 7.2.3.4 Data

The <data> in a transmission shall be in multiples of eight (8) encoded data bits (CD0s and CD1s).

### 7.2.3.5 End of transmission delimiter

The <etd> delimiter indicates the end of a transmission and serves to turn off the transmitter. The signal shall be start of IDL.

## 7.2.4 PLS functions

The PLS sublayer functions consist of a Reset and Identify function and five simultaneous and asynchronous functions. These functions are Output, Input, Mode, Error Sense, and Carrier Sense. All of the five functions are started immediately following the completion of the Reset and Identify function. These functions are depicted in the state diagrams shown in Figure 7–3 through Figure 7–8, using notation described in 1.2.1.

### 7.2.4.1 Reset and Identify function

The Reset and Identify function is executed any time either of two conditions occur. These two conditions are “power on” and the receipt of RESET\_REQUEST from the management entity. The Reset and Identify function initializes all PLS functions, and (optionally) determines the capability of the MAU attached to the AUI. Figure 7–3 is the state diagram of the Reset and Identify function. The Identify portion of the function is optional.

### 7.2.4.2 Mode function

The MAU functions in two modes: normal and monitor. The monitor mode is optional. The state diagram of Figure 7–4 depicts the operation of the Mode function. When the MAU is operating in the normal mode, it functions as a direct connection between the DTE and the medium. Data sent from the DTE are impressed onto the medium by the MAU and all data appearing on the medium are sent to the DTE by the MAU. When the MAU is operating in the monitor mode, data appearing on the medium is sent to the DTE by the MAU as during the normal mode. *signal\_quality\_error* is also asserted on the AUI as during operation in the normal mode. However, in the monitor mode, the means employed to impress data on the physical medium is positively prevented from affecting the medium. Since signaling and isolation techniques differ from medium to medium, the manner in which this positive isolation of the transmitting means is accomplished is specified in the appropriate MAU document. However, the intent of this positive isolation of the transmitter is to ensure that the MAU will not interfere with the physical medium in such a way as to affect transmission of other stations even in the event of failure of the normal transmitter disabling control paths within the transmitting mechanism of the MAU.

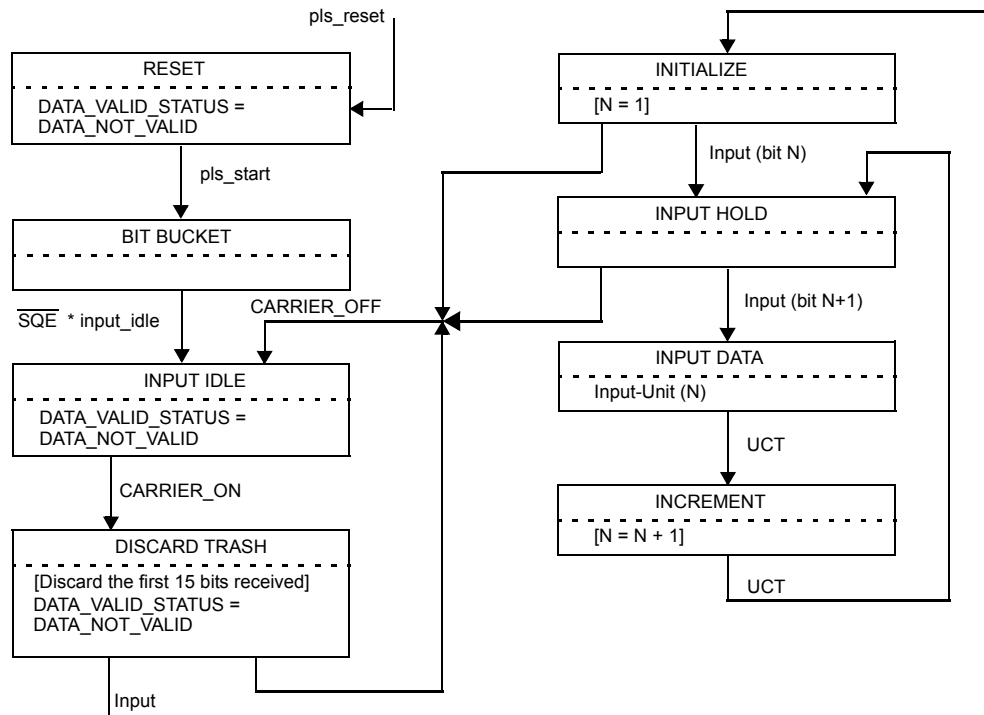


Figure 7–6—PLS Input and Data\_Valid function

The monitor mode is intended to permit a network station to determine if it is the source of interference observed on the medium.

NOTE—The monitor mode is intended to be used only by Network Management for fault isolation and network operation verification. It is intended that the *isolate* message provide direct control over the mode function so that these tasks can be performed. IMPROPER USE OF THE ISOLATE FUNCTION CAN CAUSE ERRONEOUS FRAMES. Clause 5, Layer Management, provides details on the proper use of this function.

### 7.2.4.3 Output function

The PLS sublayer Output function transparently performs the tasks of conditioning the MAU for output and data transfer from the MAC sublayer to the MAU. The state diagram of Figure 7–5 depicts the Output function operation.

At the conclusion of the Output function, if a collision has not occurred, a test is performed to verify operation of the signal quality detection mechanism in the MAU and to verify the ability of the AUI to pass the *signal\_quality\_error* message to the PLS sublayer. The operation of this test in the DTE is shown in Figure 7–8.

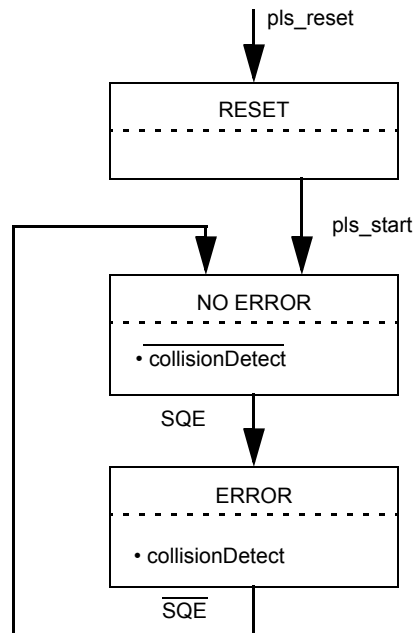
NOTE—In systems operating in full duplex mode, it is permitted, but not required, to implement the *signal\_quality\_error* message test.

### 7.2.4.4 Input function

The PLS sublayer Input function transparently performs the task of data transfer from the MAU to the MAC sublayer. Additionally, the Input function sends DATA\_VALID\_STATUS to the MAC sublayer, as appropriate. The state diagram of Figure 7–6 depicts the Input function operation.

### 7.2.4.5 Error Sense function

The PLS sublayer Error Sense function performs the task of sending collisionDetect to the MAC sublayer whenever the PLS receives the *signal\_quality\_error* message from the PMA sublayer. The state diagram of Figure 7–7 depicts the Error Sense function operation.



NOTE—SQE = *signal\_quality\_error*

Figure 7–7—PLS Error Sense function

### 7.2.4.6 Carrier Sense function

The PLS sublayer Carrier Sense function performs the task of sending carrierSense and sqeTestError to the MAC sublayer. The state diagram of Figure 7–8 depicts the Carrier Sense function operation.<sup>26</sup>

Verification of the *signal\_quality\_error* detection mechanism occurs in the following manner (in the absence of a fault on the medium):

- a) At the conclusion of the Output function, the DTE opens a time window during which it expects to see the *signal\_quality\_error* message asserted on the Control In circuit. The time window begins when carrierSense de-asserts and the variable transmitting is false. The duration of the window shall be at least 4.0  $\mu$ s but no more than 8.0  $\mu$ s. During the time window (depicted as carrier\_inhibit\_timer, Figure 7–8) the carrierSense function is inhibited.
- b) The MAU, upon waiting Tw after the conclusion of output, activates as much of the *signal\_quality\_error* detecting mechanism as is possible without placing signals on the medium, thus sending the *signal\_quality\_error* message across the AUI for 10 bit times  $\pm$  5 bit times (10/BR seconds  $\pm$  5/BR seconds).
- c) The DTE interprets the reception of the *signal\_quality\_error* message from the MAU as indication that the *signal\_quality\_error* detecting mechanism is operational and the *signal\_quality\_error* message may be both sent by the MAU and received by the DTE.

NOTE 1—The occurrence of multiple (overlapping) transmitters on the medium during the time that the test window is open, as specified above, will satisfy the test and will verify proper operation of the signal quality error detecting mechanism and sending and receiving of the appropriate physical error message.

NOTE 2—If *signal\_quality\_error* exists at the DTE before CARRIER\_OFF occurs, then the Collision Presence test sequence within the PLS as described in 7.2.4.3 above shall be aborted as shown in Figure 7–8.

NOTE 3—In systems operating in full duplex mode, it is permitted, but not required, to implement the *signal\_quality\_error* message test.

## 7.3 Signal characteristics

### 7.3.1 Signal encoding

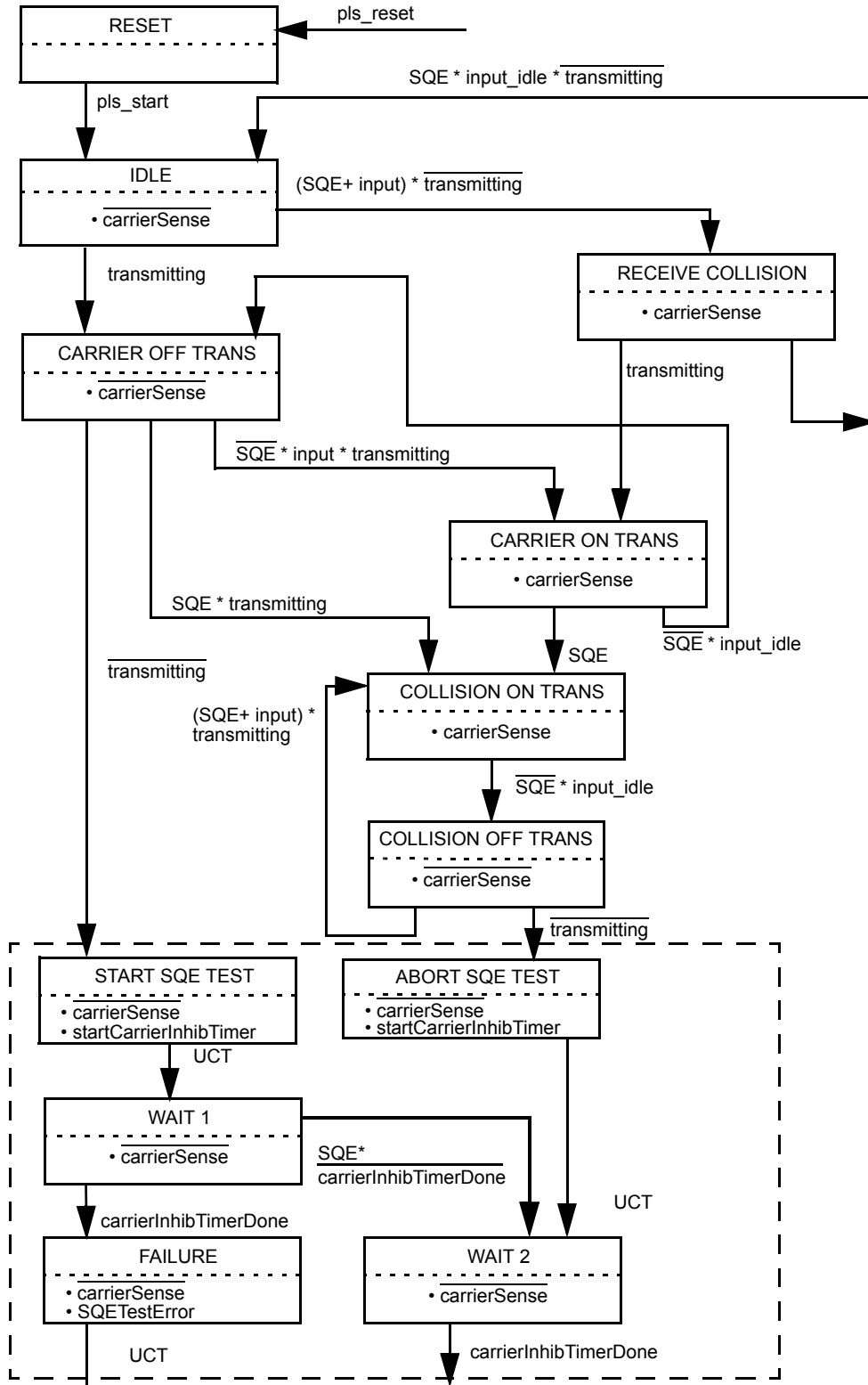
Two different signal encoding mechanisms may be used by the AUI. One of the mechanisms is used to encode data, the other to encode control.

#### 7.3.1.1 Data encoding

Manchester encoding is used for the transmission of data across the AUI. Manchester encoding is a binary signaling mechanism that combines data and clock into “bit-symbols.” Each bit-symbol is split into two halves with the second half containing the binary inverse of the first half; a transition always occurs in the middle of each bit-symbol. During the first half of the bit-symbol, the encoded signal is the logical complement of the bit value being encoded. During the second half of the bit-symbol, the encoded signal is the uncomplemented value of the bit being encoded. Thus, a CD0 is encoded as a bit-symbol in which the first half is HI and the second half is LO. A CD1 is encoded as a bit-symbol in which the first half is LO and the second half is HI. Examples of Manchester waveforms are shown in Figure 7–10.

<sup>26</sup>Formerly, this function utilized the variable output\_in\_process generated by the PLS output function described in Figure 7–5. For the sake of consistency with common implementation practice, the variable transmitting (see 4.3.3) is utilized directly by the PLS Carrier Sense function in recent editions of the standard.

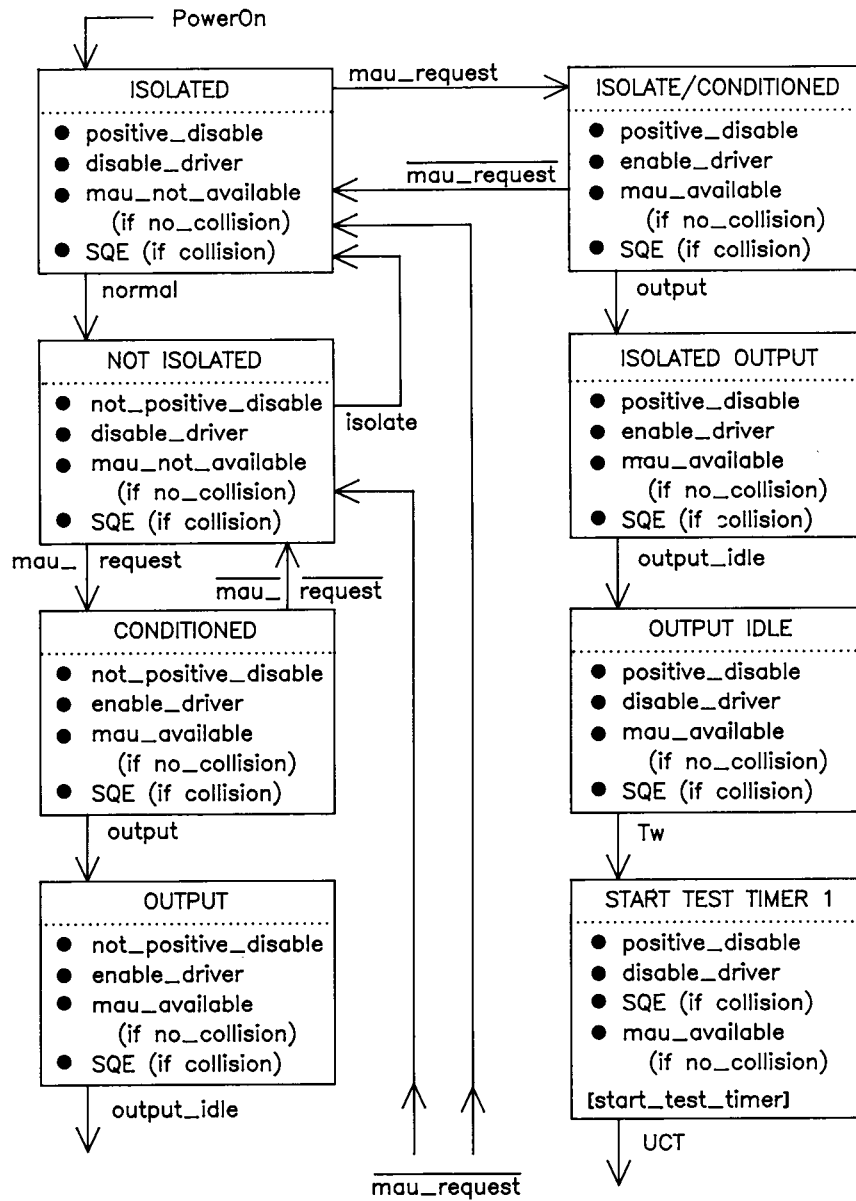
The mapping between variable output\_in\_process and the variable transmitting is as follows. When output\_in\_process is true, transmitting is true; when output\_in\_process is false, transmitting is false.



NOTE 1—UCT is unconditional transition; SQE is *signal\_quality\_error*.  
NOTE 2—States within the dotted box are not implemented for the PLS sublayer within a repeater port.

Figure 7-8—PLS Carrier Sense function



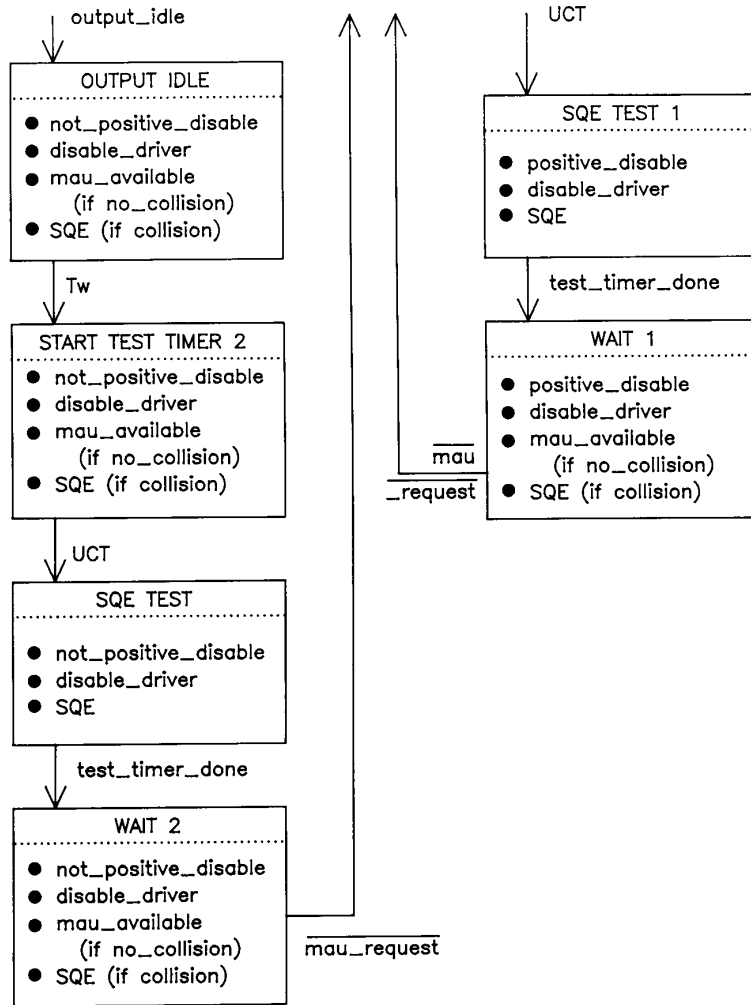


NOTE—See Figure 8-2 and Figure 8-3 for simple and isolate type MAUs.

a)

**Figure 7-9—Interface function for MAU with conditioning**

The line condition IDL is also used as an encoded signal. An IDL always starts with a HI signal level. Since IDL always starts with a HI signal, an additional transition will be added to the data stream if the last bit sent was a zero. This transition cannot be confused with clocked data (CD0 or CD1) since the transition will occur at the start of a bit cell. There will be no transition in the middle of the bit cell. The IDL condition, as sent by a driver, shall be maintained for a minimum of 2 bit times. The IDL condition shall be detected within 1.6 bit times at the receiving device.



NOTE—See Figure 8–2 and Figure 8–3 for simple and isolate type MAUs.

b)

**Figure 7–9—(Continued) Interface function for MAU with conditioning**

- a) System jitter considerations make detection of IDL (etd, end transmission delimiter) earlier than 1.3 bit times impractical. The specific implementation of the phase-locked loop or equivalent clock recovery mechanism determines the lower bound on the actual IDL detection time. Adequate margin between lower bound and 1.6 bit times should be considered.
- b) Recovery of timing implicit in the data is easily accomplished at the receiving side of the interface because of the wealth of binary transitions guaranteed to be in the encoded waveform, independent of the data sequence. A phase-locked loop or equivalent mechanism maintains continuous tracking of the phase of the information on the Data circuit.

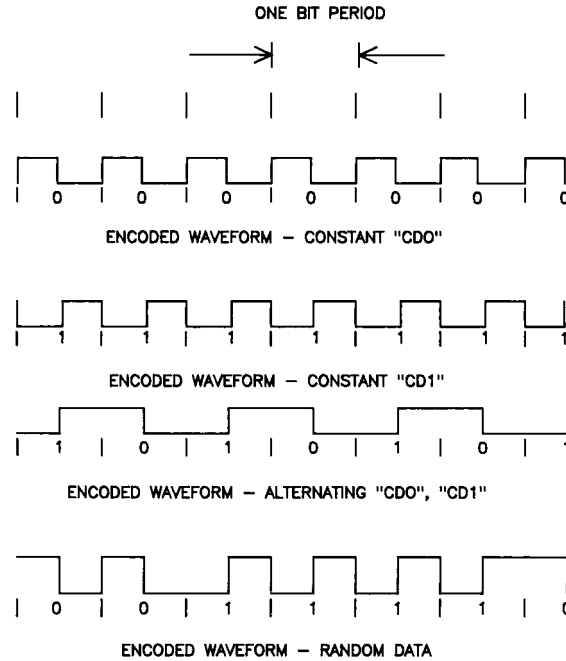


Figure 7-10—Examples of Manchester waveforms

### 7.3.1.2 Control encoding

A simpler encoding mechanism is used for control signaling than for data signaling. The encoded symbols used in this signaling mechanism are CS0, CS1, and IDL. The CS0 signal is a signal stream of frequency equal to the bit rate (BR). The CS1 signal is a signal stream of frequency equal to half of the bit rate (BR/2). If the interface supports more than one bit rate (see 4.2), the bit rate in use on the data circuits is the one to which the control signals are referenced. The IDL signal used on the control circuits is the same as the IDL signal defined for the data circuits (see 7.3.1.1). The Control Out circuit is optional (O) as is one message on Control In.

The frequency tolerance of the CS1 and CS0 signals on the CO circuit shall be  $\pm 5\%$  and that of the CS1 signal on the CI circuit shall be  $\pm 15\%$ . The duty cycle of the above signals is nominally 50%/50% and shall be no worse than 60%/40%. The CS0 signal on the CI circuit shall have a frequency tolerance of BR +25%, -15% with the pulse widths no less than 35 ns and no greater than 70 ns at the zero crossing points.

The meaning of the signals on the Control Out circuit (DTE to MAU) are as follows:

Signal	Message	Description
IDL	normal	Instructs the MAU to enter (remain in) normal mode
CS1	<i>mau_request</i> (O)	Requests that the MAU should be made available
CS0	<i>isolate</i> (O)	Instructs the MAU to enter (remain in) monitor mode

The meaning of the signals on the Control In circuit (MAU to DTE) are as follows:

Signal	Message	Description
IDL	mau_available	Indicates that the MAUs ready to output data
CS1	mau_not_available	Indicates that the MAU is not ready to output data
CS0	<i>signal_quality_error</i>	Indicates that the MAU has detected an error output data

### 7.3.2 Signaling rate

Multiple signaling rates are encompassed by this standard. The signaling rate specified here is 10 million bits per second  $\pm 0.01\%$ .

It is intended that a given MDI operate at a single data rate. It is not precluded that specific DTE and MAU designs be manually switched or set to alternate rates. A given local network shall operate at a single signaling rate. To facilitate the configuration of operational systems, DTE and MAU devices shall be labeled with the actual signaling rate used with that device.

### 7.3.3 Signaling levels

Exact voltage and current specifications are listed in 7.4.

## 7.4 Electrical characteristics

Terms BR and BR/2 have very specific meaning as used in this subclause. The term BR is used to mean the bit rate of the highest signaling rate supported by any one implementation of this interface, BR/2 is used to mean half the bit rate of the lowest signaling rate supported by any one implementation of this interface (see 7.3.2). An interface may support one or more signaling rates.

NOTE—The characteristics of the driver and receiver can be achieved with standard ECL logic with the addition of an appropriate coupling network; however, this implementation is not mandatory.

### 7.4.1 Driver characteristics

The driver is a differential driver capable of driving the specified  $78\ \Omega$  interface cable. Only the parameters necessary to ensure compatibility with the specified receiver and to assure personnel safety at the interface connector are specified in the following subclauses.

#### 7.4.1.1 Differential output voltage, loaded

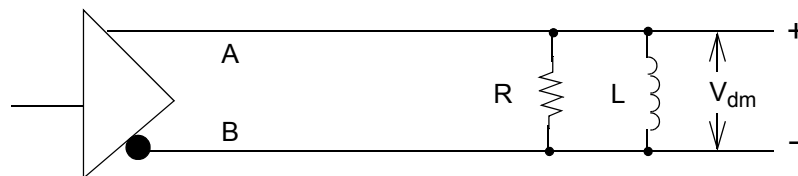
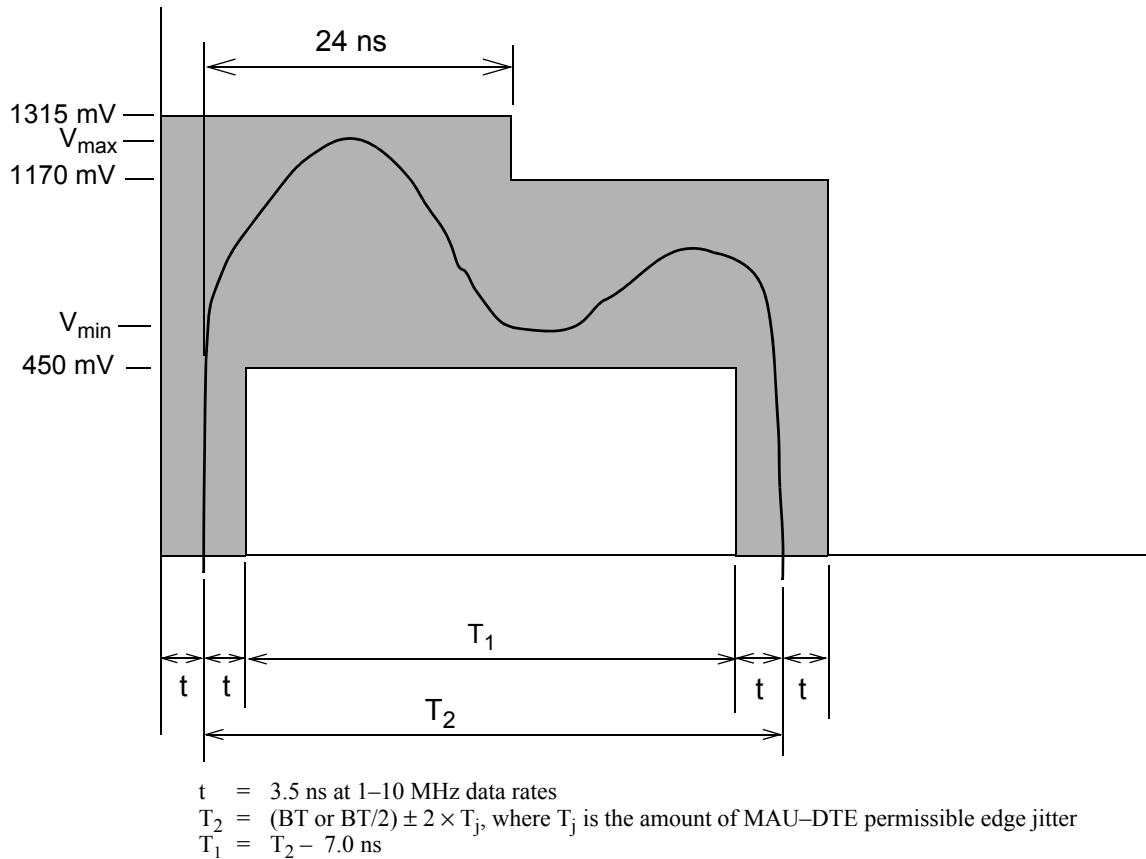
Drivers shall meet all requirements of this subclause under *two* basic sets of test conditions (that is, each of two resistive values). For drivers located within a DTE, a combined inductive load of  $27\ \mu\text{H} \pm 1\%$  and either a  $73\ \Omega$  or  $83\ \Omega \pm 1\%$  resistive load shall be used. For a driver located within a MAU, a combined inductive load of  $50\ \mu\text{H} \pm 1\%$  and either  $73\ \Omega$  or  $83\ \Omega \pm 1\%$  resistive load shall be used.

The differential output voltage,  $V_{\text{dm}}$ , is alternately positive and negative in magnitude with respect to zero voltage. The value of  $V_{\text{dm}}$  into either of the two test loads identified above ( $R = 73\ \Omega$  or  $83\ \Omega \pm 1\%$ ) at the interface connector of the driving unit shall satisfy conditions defined by values  $V_{\text{min}}$  and  $V_{\text{max}}$  shown in Figure 7–11 for signals in between BR and BR/2 meeting the frequency and duty cycle tolerances specified for the signal being driven. The procedure for measuring and applying the test condition is as follows:

- a) Construct a template representing the shaded area of Figure 7–11. Once constructed, the template may be shifted along the time axis in order to accommodate differences in the 10% to 50% and 50% to 90% transition times of the driver waveform.
- b) Find the peak value of  $V_{\text{dm}}$ . This is  $V_{\text{max}}$ .
- c) Find the minimum value of  $V_{\text{dm}}$  during the period between the shaded regions for the waveform's rising and falling transitions (time T1 in Figure 7–11). This minimum value is  $V_{\text{min}}$ .
- d)  $V_{\text{max}}$  shall be  $< 1315\ \text{mV}$ ,  $V_{\text{min}}$  shall be  $> 450\ \text{mV}$ , and  $V_{\text{max}}/V_{\text{min}}$  shall be  $< 1.37$ .
- e)  $V_{\text{dm}}$  shall remain  $< 1170\ \text{mV}$  24 ns after a zero crossing.
- f) The waveform shall remain within the shaded area limits.

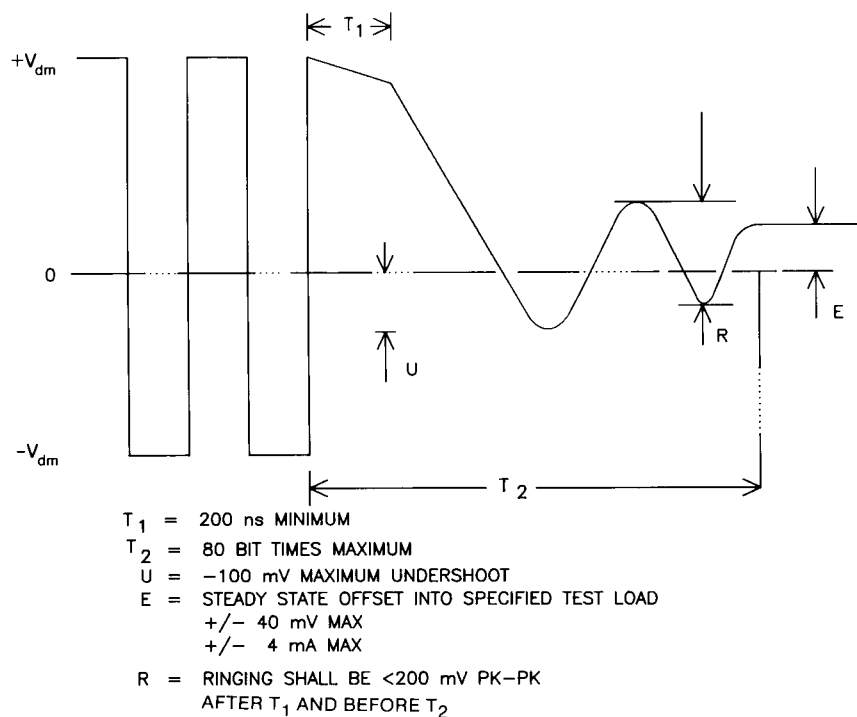
The differential output voltage magnitude,  $V_{dm}$ , into either of the two test loads identified above, at the interface connector of the driving unit during the idle state shall be within 40 mV of 0 V. The current into either of the two test loads shall be limited to 4 mA.

When a driver, connected to the appropriate two test loads identified above, enters the idle state, it shall maintain a minimum differential output voltage of at least 380 mV for at least 2 bit times after the last low to high transition.



**Figure 7-11—Differential output voltage, loaded**

For drivers on either the CO or CI circuits, the first transition or the last positive going transition may occur asynchronously with respect to the timing of the following transitions or the preceding transition(s), respectively.



**Figure 7-12—Generalized driver waveform**

#### 7.4.1.2 Requirements after idle

When the driver becomes nonidle after a period of idle on the interface circuit, the differential output voltage at the interface connector shall meet the requirements of 7.4.1.1 beginning with the second bit transmitted. The first bit sent over the driver circuit may contain phase violations or invalid data.

#### 7.4.1.3 AC common-mode output voltage

The magnitude of the ac component of the common-mode output voltage of the driver, measured between the midpoint of a test load consisting of a pair of matched  $39 \Omega \pm 1\%$  resistors and circuit VC, as shown in Figure 7-13, shall not exceed 2.5 V peak from 30 Hz to 40 kHz and 160 mV peak from 40 kHz to BR.

#### 7.4.1.4 Differential output voltage, open circuit

The differential output voltage into an open circuit, measured at the interface connector of the driving unit, shall not exceed 13 V peak.

#### 7.4.1.5 DC common-mode output voltage

The magnitude of the dc component of the common-mode output voltage of the driver, measured between the midpoint of a test load consisting of a pair of matched  $39 \Omega \pm 1\%$  resistors and circuit VC, as shown in Figure 7-13, shall not exceed 5.5 V.

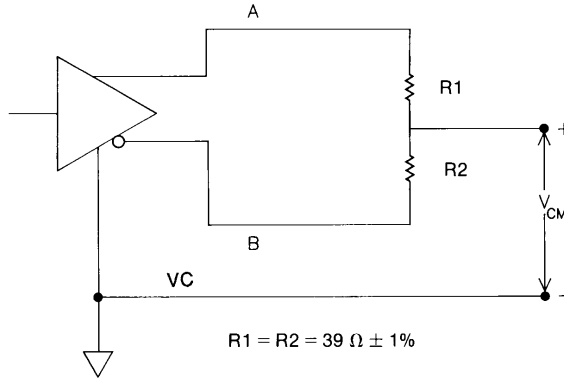


Figure 7–13—Common-mode output voltage

7.4.1.6 Fault tolerance

Any single driver in the interface, when idle or driving any permissible signal, shall tolerate the application of each of the faults specified by the switch settings in Figure 7–14 indefinitely; and after the fault condition is removed, the operation of the driver, according to the specifications of 7.4.1.1 through 7.4.1.5, shall not be impaired.

In addition, the magnitude of the output current from either output of the driver under any of the fault conditions specified shall not exceed 150 mA.

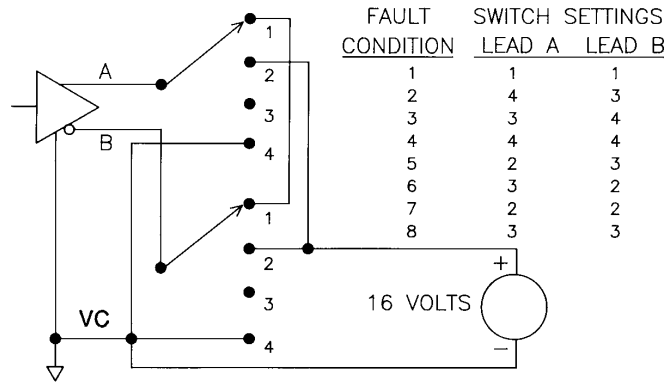


Figure 7–14—Driver fault conditions

7.4.2 Receiver characteristics

The receiver specified terminates the interface cable in its characteristic impedance. The receiver shall function normally over the specified dc and ac common-mode ranges.

7.4.2.1 Receiver threshold levels

When the receiving interface circuit at the interface connector of the receiving equipment is driven by a differential input signal at either BR or BR/2 meeting the frequency and duty cycle tolerances specified for the receiving circuit, when the A lead is 160 mV positive with respect to the B lead, the interface circuit is in the

HI state, and when the A lead is 160 mV negative with respect to the B lead, the interface circuit is in the LO state. The receiver output shall assume the intended HI and LO states for the corresponding input conditions.

If the receiver has a squelch feature, the specified receive threshold levels apply only when the squelch is allowing the signal to pass through the receiver.

NOTE—The specified threshold levels do not take precedence over the duty cycle and jitter tolerance specified elsewhere. Both sets of specifications must be met.

#### 7.4.2.2 AC differential input impedance

The ac differential input impedance for AUI receivers located in MAUs shall have a real part of  $77.83 \Omega \pm 6\%$ , with the sign of the imaginary part positive, and the phase angle of the impedance in degrees less than or equal to 0.0338 times the real part of the impedance, when measured with a 10 MHz sine wave.

The ac differential input impedance for AUI receivers located in the DTE shall have a real part of  $77.95 \Omega \pm 6\%$ , with the sign of the imaginary part positive, and the phase angle of the impedance in degrees less than or equal to 0.0183 times the real part of the impedance, when measured with a 10 MHz sine wave.

A  $78 \Omega \pm 6\%$  resistor in parallel with an inductance of greater than 27  $\mu\text{H}$  or 50  $\mu\text{H}$  for receivers in the MAU and DTE respectively, satisfies this requirement.

#### 7.4.2.3 AC common-mode range

When the receiving interface circuit at the receiving equipment is driven by a differential input signal at either BR or BR/2 meeting the frequency and duty cycle tolerances specified for the circuit being driven, the receiver output shall assume the proper output state as specified in 7.4.2.1, in the presence of a peak common-mode ac sine wave voltage either of from 30 Hz to 40 kHz referenced to circuit VC in magnitude from 0 V to 3 V, or in magnitude 0 V to 200 mV for ac voltages of from 40 kHz to BR as shown in Figure 7–15.

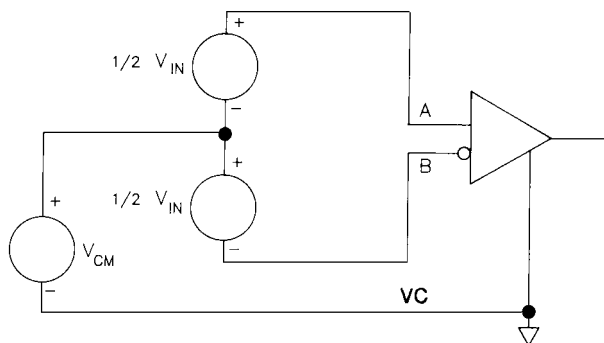


Figure 7–15—Common-mode input test

#### 7.4.2.4 Total common-mode range

When the receiving interface circuit at the receiving equipment is driven by a differential input signal at either BR or BR/2 meeting the frequency and duty cycle tolerances specified for the circuit being driven, the receiver output shall assume the intended output state as specified in 7.4.2.1 in the presence of a total common-mode voltage, dc plus ac, referenced to circuit VC in magnitude from 0 V to 5.5 V, as shown in the test setup of Figure 7–15. The ac component shall not exceed the requirements of 7.4.2.3.

The receiver shall be so designed that the magnitude of the current from the common-mode voltage source used in the test shall not exceed 1 mA.



### 7.4.2.5 Idle input behavior

When the receiver becomes nonidle after a period of idle on the interface circuit, the characteristics of the signal at the output of the receiver shall stabilize within the startup delay allowed for the device incorporating the receiver so that it is not prevented from meeting the jitter specifications established for that device.

The receiving unit shall take precautions to ensure that a HI to idle transition is not falsely interpreted as an idle to nonidle transition, even in the presence of signal droop due to ac coupling in the interface driver or receiver circuits.

### 7.4.2.6 Fault tolerance

Any single receiver in the interface shall tolerate the application of each of the faults specified by the switch settings in Figure 7–16 indefinitely, and after the fault condition is removed, the operation of the receiver according to the specifications of 7.4.2.1 through 7.4.2.6 shall not be impaired.

In addition, the magnitude of the current into either input of the receiver under any of the fault conditions specified shall not exceed 3 mA.

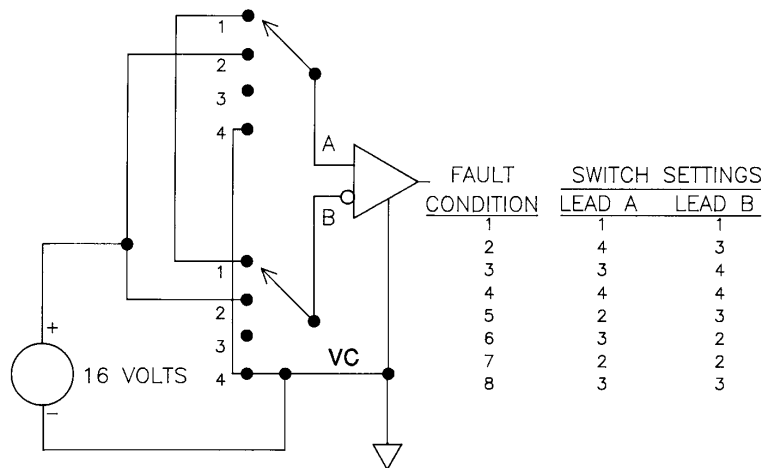


Figure 7–16—Receiver fault conditions

### 7.4.3 AUI cable characteristics

The interface cable consists of individually shielded twisted pairs of wires with an overall shield covering these individual shielded wire pairs. These shields must provide sufficient shielding to meet the requirements of protection against rf interference and the following cable parameters. Individual shields for each signal pair are electrically isolated from the outer shield but not necessarily from each other.

The overall shield shall be returned to the MAU and DTE Units via the AUI connector shell as defined in 7.6.2 and 7.6.3. If a common drain wire is used for all the signal pair shields, then it shall be connected to pin 4 and pin 1. Individual drain wire returns for each signal pair may be used (see 7.6.3). It is recommended that individual drain wires be used on all control and data circuit shields to meet satisfactory crosstalk levels. If individual drain wires are used, they shall be interconnected within the AUI cable at each end and shall be connected at least to pin 4 and pin 1 at each end of the cable.

The presence of the Control Out signal pair is optional. If driver or receiver circuit components for CO are not provided, consideration should be given to properly terminating the CO signal pair within the DTE and MAU to preclude erroneous operation.

#### 7.4.3.1 Conductor size

The dc power pair in the interconnecting cable, voltage common and voltage minus, shall be composed of a twisted pair of sufficient gauge stranded wires to result in a nominal dc resistance not to exceed 1.75  $\Omega$  per conductor.

Conductor size for the signal pairs shall be determined according to the ac related parameters in 7.4.3.2 through 7.4.3.6.

#### 7.4.3.2 Pair-to-pair balanced crosstalk

The balanced crosstalk from one pair of wires to any other pair in the same cable sheath (when each pair is driven per 7.4.1.1 through 7.4.1.5) shall have a minimum value of 40 dB of attenuation measured over the range of BR/2 to BR.

#### 7.4.3.3 Differential characteristic impedance

The differential characteristic impedance for all signal pairs shall be equal within 3  $\Omega$  and shall be  $78 \Omega \pm 5 \Omega$  measured at a frequency of BR.

#### 7.4.3.4 Transfer impedance

- a) The common-mode transfer impedance shall not exceed the values shown in Figure 7–17 over the indicated frequency range.
- b) The differential mode transfer impedance for all pairs shall be at least 20 dB below the common-mode transfer impedance.

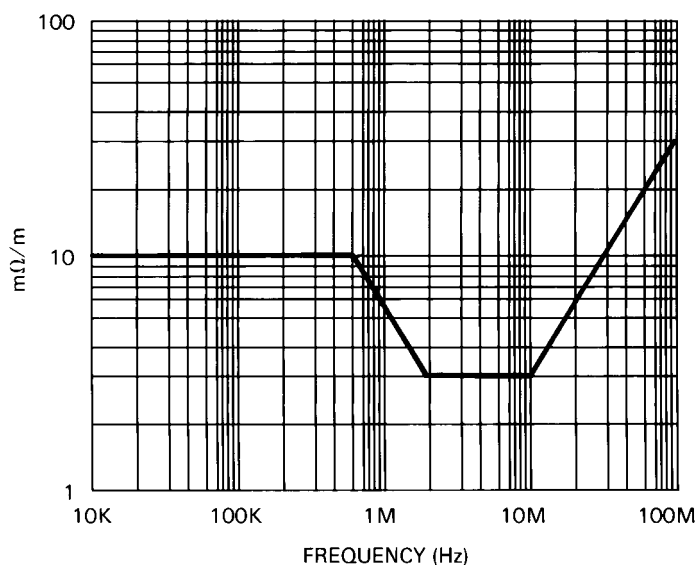


Figure 7–17—Common-mode transfer impedance

### 7.4.3.5 Attenuation

Total cable attenuation levels between driver and receiver (at separate stations) for each signal pair shall not exceed 3 dB over the frequency range of BR/2 to BR (Hz) for sinewave measurements.

### 7.4.3.6 Timing jitter

Cable meeting this specification shall exhibit edge jitter of no more than 1.5 ns at the receiving end when the longest legal length of the cable as specified in 7.4.3.1 through 7.4.3.7 is terminated in a  $78 \Omega \pm 1\%$  resistor at the receiving end and is driven with pseudorandom Manchester encoded binary data from a data generator which exhibits no more than 0.5 ns of edge jitter on half bit cells of exactly 1/2 BT and whose output meets the specifications of 7.4.1.1 through 7.4.1.5. This test shall be conducted in a noise-free environment. The above specified component is not to introduce more than 1 ns of edge jitter into the system.

NOTE—Special attention will have to be applied to the cable characteristics and length at 20 Mb/s.

### 7.4.3.7 Delay

Total signal delay between driver and receiver (at separate stations) for each signal pair shall not exceed 257 ns.

## 7.5 Functional description of interchange circuits

### 7.5.1 General

The AUI consists of either three or four differential signal circuits, power, and ground. Two of the circuits carry encoded data and two carry encoded control information. Circuits DO (Data Out) and CO (Control Out) are sourced by the DTE, and circuits DI (Data In) and CI (Control In) are sourced by the MAU. The interface also provides for power transfer from the DTE to the MAU. The CO circuit is optional.

### 7.5.2 Definition of interchange circuits

The following circuits are defined by this specification:

Circuit	Name	Signal direction		Remarks
		to MAU	from MAU	
DO	Data Out	X		Encoded Data
DI	Data In		X	Encoded Data
CO	Control Out	X		Encoded Control
CI	Control In		X	Encoded Control
VP	Voltage Plus	X		12 V
VC	Voltage Common	X		Return for VP
PG	Protective Ground	X		Shield

### 7.5.2.1 Circuit DO—Data Out

The Data Out (DO) circuit is sourced by the DTE. It is a differential pair consisting of DO-A (Data Out circuit A) and DO-B (Data Out circuit B).

The signal transferred over this circuit is Manchester encoded. An *output* message containing a one bit is encoded as CD1. An *output\_idle* message is encoded as an IDL.

The following symmetry requirements shall be met when the DTE transfers pseudorandom Manchester encoded binary data over a DO circuit loaded by the test load specified in 7.4.1.1.

Bit cells generated internal to the DTE are required to be 1 BT within the permitted tolerance on data rate specified in 7.3.2. Half bit cells in each data bit are to be exactly 1/2 BT (that is, the reference point for edge jitter measurements) within the permitted tolerance on the data rate specified in 7.3.2. Each transition on the DO circuit is permitted to exhibit edge jitter not to exceed 0.5 ns in each direction. This means that any transition may occur up to 0.5 ns earlier or later than this transition would have occurred had no edge jitter occurred on this signal.

### 7.5.2.2 Circuit DI—Data In

The Data In (DI) circuit is sourced by the MAU. It is a differential pair consisting of DI-A (Data In circuit A) and DI-B (Data In circuit B).

The signal transferred over this circuit is Manchester encoded. An *input* message containing a zero bit is encoded as CD0. An *input* message containing a one bit is encoded as CD1. An *input\_idle* message is encoded as an IDL.

A DTE meeting this specification shall be able to receive, on the DI circuit without a detectable FCS error, normal preamble data arranged in legal length packets as sent by another station to the DTE. The test generator for the data on the DI circuit shall meet the requirements for drivers in MAUs specified in 7.4.1.1 through 7.4.1.5 and shall drive the DI circuit through a zero length AUI cable. Random amounts of edge jitter from 0 ns to 12 ns on either side of each transition shall be added by the test generator to transitions in bits in the preamble, and random amounts of edge jitter of from 0 ns to 18 ns on either side of each transition shall be added to the transitions in all bits in the frame. Preamble length from the test generator shall be 47 bits of preamble, followed by the 8 bit SFD.

NOTE—A significant portion of the system jitter may be nonrandom in nature and consists of a steady-state shift of the midbit transitions in either direction from their nominal placement. A 16.5 ns edge jitter is expected on the transmitted signal at the receiving DTE, worst case. The difference between 16.5 ns and 18 ns jitter represents receiver design margin.

### 7.5.2.3 Circuit CO—Control Out (optional)

The Control Out (CO) circuit is sourced by the DTE. It is a differential pair consisting of CO-A (Control Out circuit A) and CO-B (Control Out circuit B).

The signal transferred over this circuit is encoded as described in 7.3.1.2. A *mau\_request* message is encoded as CS1. A *normal* message is encoded as IDL. An *isolate* message is encoded as CS0.

### 7.5.2.4 Circuit CI—Control In

The Control In (CI) circuit is sourced by the MAU. It is a differential pair consisting of CI-A (Control In circuit A) and CI-B (Control In circuit B).

The signal transferred over this circuit is encoded as described in 7.3.1.2. A *mau\_available* message is encoded as IDL. A *mau\_not\_available* message is encoded as CS1. A *signal\_quality\_error* message is encoded as a CS0.

#### 7.5.2.5 Circuit VP—Voltage Plus

The Voltage Plus (VP) circuit is sourced from the DTE. It shall be capable of operating at one fixed level between + 12 V dc – 6% and + 15 V dc + 5% with respect to circuit VC at the DTE AUI for all currents from 0 to 500 mA. The source shall provide protection for this circuit against an overload condition. The method of overload protection is not specified; however, under no conditions of operation, either normal or overload, shall the source apply a voltage to circuit VP of less than 0 or greater than + 15.75 V dc as specified above. MAU designers are cautioned that protection means employed by power sources may cause the voltage at signal VP to drop below the minimum operational voltage specified without going completely to zero volts when loads drawing in excess of the current supplied are applied between VP and VC. Adequate provisions shall be made to ensure that such a condition does not cause the MAU to disrupt the medium.

#### 7.5.2.6 Circuit VC—Voltage Common

Circuit VC is the ground return to the power source for circuit VP, capable of sinking 2.0 A. Also, all common-mode terminators for AUI circuits shall be made to circuit VC.

#### 7.5.2.7 Circuit PG—Protective Ground

Circuit PG shall be connected to chassis ground through a maximum dc resistance of 20 m $\Omega$  at the DTE end.

#### 7.5.2.8 Circuit shield terminations

Individual pin terminations shall meet the following requirements:

- a) Pins 1, 4, 8, 11, 14 connected to logic ground in the DTE
- b) Pins 1, 4, 8, 11, 14 capacitively coupled to VC in MAU
- c) Impedance to ground < 5  $\Omega$  at the lowest operational BR/2 in the MAU and at the highest BR in the DTE

### 7.6 Mechanical characteristics

#### 7.6.1 Definition of mechanical interface

All connectors used shall be as specified in 7.6.2. The DTE shall have a female connector and the MAU shall have a male connector. The MAU may be plugged directly into the DTE or may be connected by one or more cable segments whose total length is less than or equal to 50 m. All cable segments shall have a male connector on one end and a female connector on the other end. All female connectors shall have the slide latch, and all male connectors shall have the locking posts (as defined in Figure 7–18, Figure 7–19, and Figure 7–20) as the retention system.

#### 7.6.2 Line interface connector

A 15-pole connector having the mechanical mateability dimensions as specified in IEC 60807-2 with gold-plated contacts shall be used for the line interface connector. The shells of these connectors shall be tin plated to ensure the integrity of the cable shield to chassis current path. The resistance of the cable shield to equipment chassis shall not exceed 5 m $\Omega$ , after a minimum of 500 cycles of mating and unmating.

In order to ensure intermateability of connectors obtained from different manufacturers, the connector with female contacts shall conform to IEC 60807-2 and have gold-plated contacts and tin-plated shells. All additions to provide for female shell to male shell conductivity shall be on the shell of the connector with male contacts. There should be multiple contact points around the sides of this shell to provide for shield continuity.

NOTE—Use of similar metallic surfaces on connector conductors and similar metallic surfaces on the connector shells minimizes galvanic action and reduced performance.

The connector is not specified to prevent operator contact with the shield, and precautions shall be taken at installation time to ensure that the installer is warned that the shield is not to be brought into contact with any hazardous voltage while being handled by operating personnel. See reference [B50].

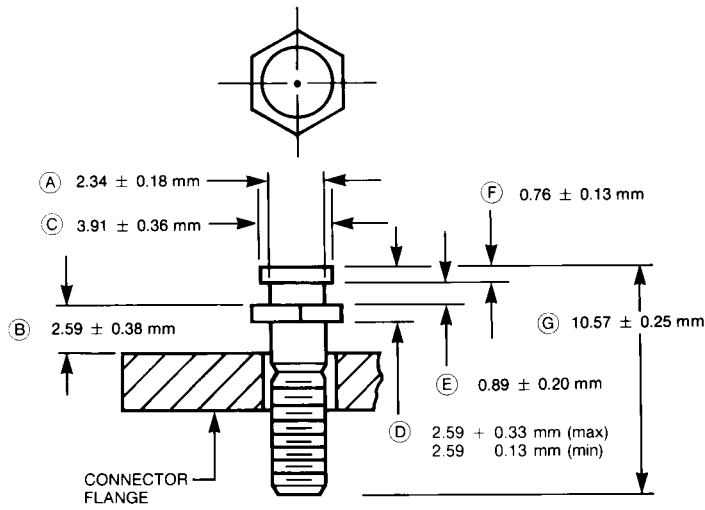
### 7.6.3 Contact assignments

The following table shows the assignment of circuits to connector contacts.

Contact	Circuit	Use
3	DO-A	Data Out circuit A
10	DO-B	Data Out circuit B
11	DO-S	Data Out circuit shield
5	DI-A	Data In circuit A
12	DI-B	Data In circuit B
4	DI-S	Data In circuit shield
7	CO-A	Control Out circuit A
15	CO-B	Control Out circuit B
8	CO-S	Control Out circuit shield
2	CI-A	Control in circuit A
9	CI-B	Control In circuit B
1	CI-S	Control In circuit shield
6	VC	Voltage Common
13	VP	Voltage Plus
14	VS	Voltage Shield
Shell	PG	Protective Ground (Conductive Shell)

NOTE—Voltage Plus and Voltage Common use a single twisted pair in the AUI cable.

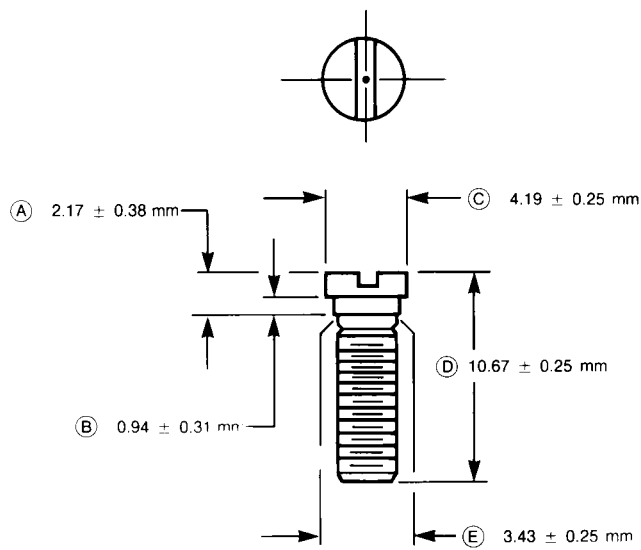
As indicated in 7.4.2.1, the A lead of a circuit is positive relative to the B lead for a HI signal and negative for a LO signal.



**LEGEND**

- A = (0.092 ± 0.007 inches)
- B = (0.102 ± 0.015 inches)
- C = (0.154 ± 0.014 inches)
- D = 0.102 ± 0.13 inches (max)  
0.102 - 0.05 inches (min)
- E = (0.035 ± 0.008 inches)
- F = (0.03 ± 0.005 inches)
- G = (0.416 ± 0.010 inches)

**LOCKING POST**

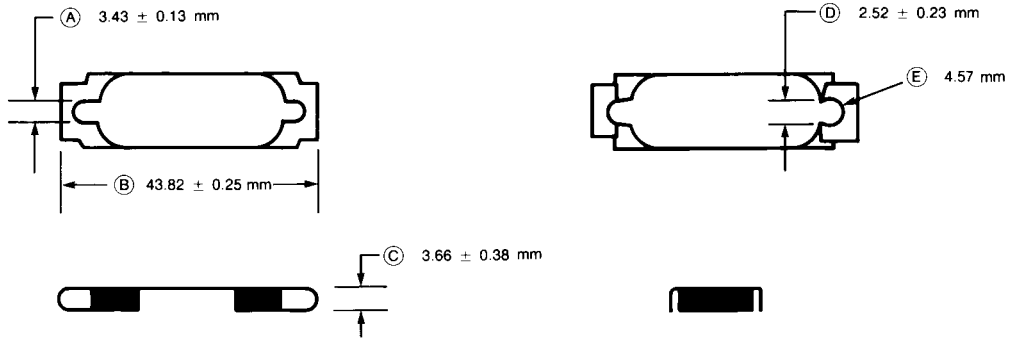


**LEGEND**

- A = (0.085 ± 0.015 inches)
- B = (0.037 ± 0.012 inches)
- C = (0.165 ± 0.010 inches diameter)
- D = (0.420 ± 0.010 inches)
- E = (0.135 ± 0.010 inches diameter)

**SLIDE LATCH SCREW**

**Figure 7-18—Connector locking posts**

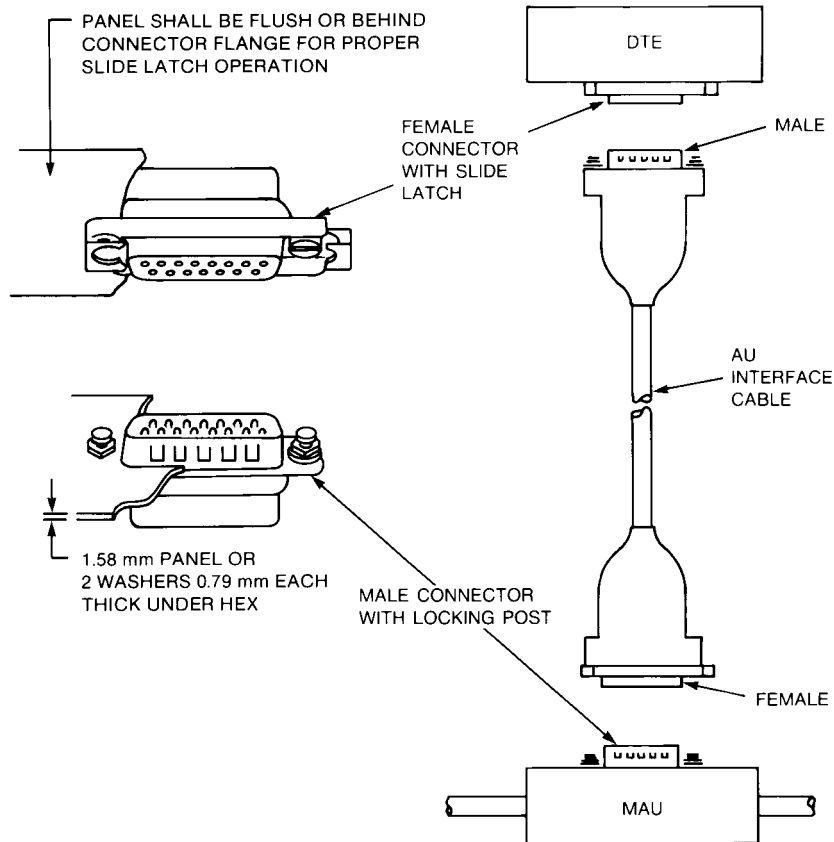


**LEGEND**

- A = (0.135 ± 0.005 inches)
- B = (1.725 ± 0.010 inches)
- C = (0.144 ± 0.015 inches)
- D = (0.099 ± 0.009 inches)
- E = (0.180 inches diam min)

**Figure 7-19—Connector slide latch**

(material 24 gauge maximum)



**Figure 7-20—Connector hardware and AUI cable configuration**



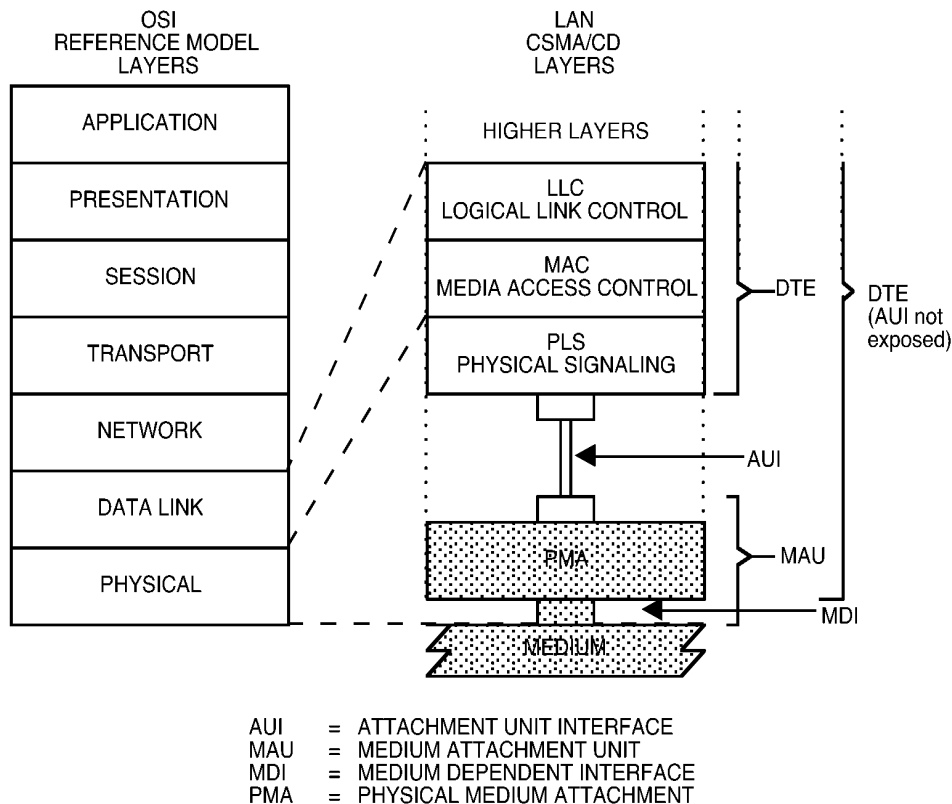
## 8. Medium Attachment Unit and baseband medium specifications, type 10BASE5

NOTE—This MAU is not recommended for new installations. Since September 2003, maintenance changes are no longer being considered for this clause.

### 8.1 Scope

#### 8.1.1 Overview

This standard defines the functional, electrical, and mechanical characteristics of the MAU and one specific medium for use with local networks. The relationship of this specification to the entire ISO/IEC Local Network International Standard is shown in Figure 8–1. The purpose of the MAU is to provide a simple, inexpensive, and flexible means of attaching devices to the local network medium.



**Figure 8–1—Physical Layer partitioning, relationship to the ISO/IEC Open Systems Interconnection (OSI) reference model**

#### 8.1.1.1 Medium Attachment Unit

The MAU has the following general characteristics:

- Enables coupling the PLS by way of the AUI to the explicit baseband coaxial transmission system defined in this clause of the standard.
- Supports message traffic at a data rate of 10 Mb/s (alternative data rates may be considered in future additions to the standard).
- Provides for driving up to 500 m of coaxial trunk cable without the use of a repeater.
- Permits the DTE to test the MAU and the medium itself.

- e) Supports system configurations using the CSMA/CD access mechanism defined with baseband signaling.
- f) Supports a bus topology interconnection means.

### **8.1.1.2 Repeater unit**

The repeater unit is used to extend the physical system topology, has the same general characteristics as defined in 8.1.1.1, and provides for coupling together two or more 500 m coaxial trunk cable segments. Multiple repeater units are permitted within a single system to provide a maximum trunk cable connection path of 2.5 km between any two MAUs.

### **8.1.2 Definitions**

See 1.4.

### **8.1.3 Application perspective: MAU and MEDIUM objectives**

This subclause states the broad objectives and assumptions underlying the specifications defined throughout this subclause of the standard.

#### **8.1.3.1 Object**

- a) Provide the physical means for communication between local network data link entities.

NOTE—This standard covers a portion of the physical layer as defined in the OSI Reference Model and, in addition, the physical medium itself, which is beyond the scope of the OSI Reference Model.

- b) Define a physical interface that can be implemented independently among different manufacturers of hardware and achieve the intended level of compatibility when interconnected in a common local network.
- c) Provide a communication channel capable of high bandwidth and low bit error ratio performance. The resultant mean bit error ratio, at the physical layer service interface should be less than one part in  $10^8$  (on the order of one part in  $10^9$  at the link level).
- d) Provide for ease of installation and service.
- e) Provide for high network availability (ability of a station to gain access to the medium and enable the data link connection in a timely fashion).
- f) Enable relatively low-cost implementations.

#### **8.1.3.2 Compatibility considerations**

All implementations of this baseband coaxial system shall be compatible at the MDI.

This standard provides one explicit trunk cable medium specification for the interconnection of all MAU devices. The medium itself, the functional capability of the MAU, and the AUI are defined to provide the highest possible level of compatibility among devices designed by different manufacturers. Designers are free to implement circuitry within the MAU in an application-dependent manner provided the MD Interface and AUI specifications are satisfied.

Subsystems based on this specification may be implemented in several different ways provided compatibility at the medium is maintained. It is possible, for example, to design an integrated station where the MAU is contained within a physical DTE system component, thereby eliminating the AUI cable. The device designer (and system user) shall then consider such factors as topological flexibility, system availability, and configurability.

### 8.1.3.3 Relationship to PLS and AU interface

This subclause defines the primary physical layer for the LAN, a layer comprised of both the physical medium and the rudimentary circuitry necessary to couple a station's message path directly to/from the medium. The complete logical physical layer of the LAN may reside physically in two distinct locations, the MAU and the DTE. Therefore, a close relationship exists between this subclause and Clause 7. This subclause specifies all of the physical medium parameters, all of the PMA logical functions residing in the physical MAU, and references the AUI associated with and defined throughout Clause 7.

NOTE—The design of a physical MAU component requires the use of both this subclause and Clause 7 for the PLS and AUI specifications.

### 8.1.3.4 Modes of operation

The MAU is capable of operating in either a “Normal” mode or an optional “Monitor” mode.

- a) *Normal mode.* The MAU functions as a direct connection between the baseband medium and the DTE. Data output from the DTE is output to the coaxial trunk medium and all data on the coaxial trunk medium is input to the DTE. This mode is the “normal” mode of operation for the intended message traffic between stations.
- b) *Monitor mode.* The MAU Transmit function is disabled to prevent data from being output on the trunk coaxial medium while the receive function and collision presence function remain active for purposes of monitoring medium message traffic. This mode also serves as a limited test mode at the same time it isolates the MAU transmitter from the medium. Under most local (that is, intrastation) fault conditions the monitor mode enables continued use of the network while the local station is being serviced.

## 8.2 MAU functional specifications

The MAU component provides the means by which signals on the four physically separate AUI signal circuits to/from the DTE and their associated interlayer messages are coupled to the single coaxial cable baseband signal line. To achieve this basic objective, the MAU component contains the following functional capabilities to handle message flow between the DTE and the baseband medium:

- a) *Transmit function.* The ability to transmit serial data bit streams on the baseband medium from the local DTE entity and to one or more remote DTE entities on the same network.
- b) *Receive function.* The ability to receive serial data bit streams over the baseband medium.
- c) *Collision Presence function.* The ability to detect the presence of two or more stations' concurrent transmissions.
- d) *Monitor function (Optional).* The ability to inhibit the normal transmit data stream to the medium at the same time the normal receive function and collision presence function remain operational.
- e) *Jabber function.* The ability to automatically interrupt the transmit function and inhibit an abnormally long output data stream.

### 8.2.1 MAU Physical Layer functions

#### 8.2.1.1 Transmit function requirements

At the start of a frame transmission on the coaxial cable, no more than 2 bits (2 full bit cells) of information may be received from the DO circuit and not transmitted onto the coaxial medium. In addition, it is permissible for the first bit sent to contain encoded phase violations or invalid data; however, all successive bits of the frame shall be reproduced with no more than the specified amount of jitter. The second bit cell transmitted onto the coaxial cable shall be carried from the DO signal line and transmitted onto the coaxial trunk

cable medium with the correct timing and signal levels. The steady-state propagation delay between the DO circuit receiver input and the coaxial cable output shall not exceed one-half bit cell. At the start of transmission, the MAU bit loss plus steady-state propagation delay between the DO and the coaxial cable shall vary by less than 2 bits between successive packets separated by 96 bit times or less. There shall be no logical signal inversions between the branch cable DO circuit and the coaxial trunk cable (for example, a “high” logic level input to the MAU shall result in the less negative current flow value on the trunk coaxial medium). A positive signal on the A signal lead of the DO circuit shall result in a more positive voltage level on the trunk coaxial medium. It is assumed that the AUI shall provide adequate protection against noise. It is recommended that the designer provide an implementation in which a minimum threshold signal is required to establish a transmit bit stream.

The Transmit function shall output a signal on the trunk coaxial medium whose levels and waveform comply with 8.3.1.3.

In addition, when the DO circuit has gone idle after a frame is output, the MAU shall then activate the collision presence function as close to the trunk coaxial cable as possible without introducing an extraneous signal on the trunk coaxial medium. The MAU shall initiate the collision presence state within 0.6  $\mu$ s to 1.6  $\mu$ s after the start of the output idle signal and shall maintain an active collision presence state for a time equivalent to 10 bit cells  $\pm$  5 bit cells.

### 8.2.1.2 Receive function requirements

The signal from the coaxial trunk cable shall be directly coupled to the receiver and subsequently ac coupled before reaching the receive circuit connected to the DTE. The receive function shall output a signal onto the DI circuit of the AUI cable that complies with the AUI specification for drivers in MAUs.

At the start of a frame reception from the coaxial cable, no more than 5 bits (five full bit cells) of information may be received from the coaxial cable and not transmitted onto the receive (DI) circuit. In addition, it is permissible for the first bit sent over the receive circuit to contain encoded phase violations or invalid data; however, all successive bits of the frame shall reproduce the incoming signal with no more than the above specified amount of jitter. This implies that the second bit cell sent onto the DI circuit presents valid data to the branch cable. The steady-state propagation delay between the coaxial cable and the receive (DI) circuit output shall not exceed one-half bit cell. At the start of reception, the MAU bit loss plus steady-state propagation delay between the coaxial cable and the DI circuit shall vary by less than 5 bits between successive packets separated by 96 bit times or less when the signal level on the coaxial cable is constant (that is, when both packets are transmitted by the same MAU). There are no logical signal inversions between the coaxial (trunk) cable and the MAU (branch) cable receive circuit.

A MAU meeting this specification shall exhibit edge jitter into the DI pair when terminated in the appropriate test load specified in 7.4.3.6, of no more than 8.0 ns in either direction when it is installed on the distant end of all lengths between 2.5 m and 500 m of the cable specified in 8.4.1.1 through 8.4.2.1.5 terminated at both ends with terminators meeting the impedance requirements of 8.5.2.1 and driven at one end with pseudorandom Manchester encoded binary data from a data generator that exhibits no more than 1.0 ns of edge jitter in either direction on half-bit cells of exactly 1/2 BT and whose output meets the specifications of 8.3.1.3 except that the risetime of the signal must be 30 ns + 0, – 2 ns. This test shall be conducted in a noise-free environment. The combination of coaxial cable and MAU receiver introduce no more than 6 ns of edge jitter into the system.

The local transmit and receive functions shall operate simultaneously while connected to the medium operating in the half duplex operating mode.

### 8.2.1.3 Collision Presence function requirements

The signal presented to the CI circuit in the absence of a collision shall be the IDL signal except when the MAU is required to signal the CS1 signal.

The signal presented to the CI circuit during the presence of a collision shall be the CS0 signal encoded as specified in 7.3.1.2. Under no conditions shall the collision presence function generate an output when only one MAU is transmitting. Table 8–1 summarizes the allowable conditions under which collisions shall be detected.

- a) Collision Assertion
  - 1) In the case where the MAU has been transmitting for at least 20 bit times before the arrival at the MAU on the coaxial cable of a transmission from another MAU, the CS0 signal shall be presented to the CI circuit no more than 17 bit times after the arrival at the MAU on the MDI of a transmission from another MAU. Arrival at the MAU shall be considered to be the time when the transmission of the other MAU causes the dc level on the MDI to become more negative.
  - 2) In all other cases where the MAU is transmitting, the CS0 signal shall be presented to the CI circuit no more than 29 bit times after the later of start of transmission by the MAU and the arrival of a transmission from another MAU.
- b) Collision De-assertion
  - 1) In the case where a collision has occurred between the MAU and one other MAU, the IDL signal shall be presented to the CI circuit no more than 17 bit times after either the end of transmission by the MAU or the arrival of the end of transmission from the other MAU, whichever occurs earlier. The arrival of the end of transmission from the other MAU shall be the time when the cessation of transmission causes the dc level on the MDI to become less negative.
  - 2) In the case where a collision has occurred between more than two MAUs, the IDL signal shall be presented to the CI circuit no more than 29 bit times after the arrival of the end of transmission from all but one MAU.

These timing conditions shall be met for all data bit patterns and combinations of MDI, MAU transmit levels, and MAU locations on the segment.

The collision presence function may, in some implementations, be able to sense an abnormal (for example, open) medium.

**Table 8–1—Generation of collision presence signal**

MAU	Numbers of transmitters		
	<2	=2	>2
Transmitting	N	Y	Y
Not transmitting	N	Y	Y
Y= shall generate SQE message N= shall not generate SQE message			

### 8.2.1.4 Monitor function requirements (optional)

Upon receipt of the *isolate* message the MAU shall, within 20 ms (implementations: solid-state preferred, relay switched permitted), disable the transmit function in such a way as to prevent both the transmission of signals on the trunk coaxial medium and any abnormal loading by the disabled transmitter on the trunk coaxial medium itself. The monitor function is intended to prevent a malfunctioning active component (for example, transmit driver) from bringing down the network. The *isolate* message shall not interact with the

receive or collision presence functions, thus permitting the normal operational mode wherein all data appearing on the trunk coaxial medium are carried to the DTE on the DI signal circuit.

NOTE—Verification for successful execution of the *isolate* message requires use of the trunk coaxial medium itself. This level of guaranteed performance requires use of system layers above the physical layer and implies some interruption of normal trunk coaxial medium message traffic.

### 8.2.1.5 Jabber function requirements

The MAU shall contain a self-interrupt capability to inhibit transmit data from reaching the medium. Hardware within the MAU (with no external message other than the detection of output data, bits, or leakage, by way of the transmit function) shall provide a nominal window of at least 20 ms to at most 150 ms during which time a normal data link frame may be transmitted. If the frame length exceeds this duration, the jabber function shall inhibit further output data from reaching the medium.

When the transmit function has been positively disabled, the MAU shall then activate the collision presence function as close to the trunk coaxial medium as possible without introducing an extraneous signal on the trunk coaxial medium. A MAU without the monitor function may reset the jabber and collision presence functions on power reset. Alternatively, a MAU without the monitor function may reset these functions after a period of 0.5 s  $\pm$  50% if the monitor function has not been implemented. If the monitor function has been implemented then it shall be used to reset the collision presence and jabber functions.

## 8.2.2 MAU interface messages

### 8.2.2.1 DTE physical layer to MAU physical layer messages

The following messages can be sent by the DTE physical layer entities to the MAU physical layer entities:

Message	Circuit	Signal	Meaning
<i>output</i>	DO	CD1, CD0	Output information
<i>output_idle</i>	DO	IDL	No data to be output
<i>normal</i>	CO	IDL	Assume the nonintrusive state on the trunk coaxial medium
(Optional circuit)			
<i>isolate</i>	CO	CS0(BR)	Positively disable the trunk coaxial medium transmitter

### 8.2.2.2 MAU physical layer to DTE physical layer

The following messages can be sent by the MAU physical layer entities to the DTE physical layer entities:

Message	Circuit	Signal	Meaning
<i>input</i>	DI	CD1, CD0	Input information
<i>input_idle</i>	DI	IDL	No information to be input
<i>mau_available</i>	CI	IDL	MAU is available for output
<i>signal_quality_error</i>	CI	CS0	Error detected by MAU

#### 8.2.2.2.1 *input* message

The MAU physical layer sends an *input* message to the DTE physical layer when the MAU has a bit of data to send to the DTE. The physical realization of the input message is a CD0 or CD1 sent by the MAU to the DTE on the data in circuit. The MAU sends CD0 if the *input* bit is a zero or CD1 if the *input* bit is a one. No retiming of the CD1 or CD0 signals takes place within the MAU.

#### 8.2.2.2.2 *input\_idle* message

The MAU physical layer sends an *input\_idle* message to the DTE physical layer when the MAU does not have data to send to the DTE. The physical realization of the *input\_idle* message is the IDL signal sent by the MAU to the DTE on the data in circuit.

#### 8.2.2.2.3 *mau\_available* message

The MAU physical layer sends the *mau\_available* message to the DTE physical layer when the MAU is available for output. The *mau\_available* message is always sent by a MAU that is always prepared to output data unless the *signal\_quality\_error* message shall be sent instead. Such a MAU does not require *mau\_request* to prepare itself for data output. The physical realization of the *mau\_available* message is an IDL signal sent by the MAU to the DTE on the control in circuit.

#### 8.2.2.2.4 *signal\_quality\_error* message

The *signal\_quality\_error* message shall be implemented in the following fashion:

- a) The *signal\_quality\_error* message shall not be sent by the MAU if no MAU or only one MAU is transmitting on the trunk coaxial medium in the normal mode.
- b) If two or more remote MAUs are transmitting on the trunk coaxial medium, but the MAU connected to the local node is not transmitting, then the local MAU shall send the *signal\_quality\_error* message.
- c) When the local MAU is transmitting on the trunk coaxial medium, all occurrences of one or more additional MAUs transmitting shall cause the *signal\_quality\_error* message to be sent by the local MAU to its DTE.
- d) When the MAU has completed each output frame it shall perform an SQE test sequence, as defined in Figure 8–2 and Figure 8–3.
- e) When the MAU has inhibited the transmit function it shall send the *signal\_quality\_error* message in accordance with the jabber function requirements of 8.2.1.5.

The physical realization of the *signal\_quality\_error* message is the CS0 signal sent by the MAU to the DTE on the control in circuit. See 8.2.1.3 for timing requirements on the assertion and de-assertion of the CS0 signal in a collision.

Note that the MAU is required to assert the *signal\_quality\_error* message at the appropriate times whenever the MAU is powered and not just when the DTE is providing output data.

### 8.2.3 MAU state diagrams

The state diagrams, Figure 8–2 (a–d), Figure 8–3, and Figure 8–4, depict the full set of allowed MAU state functions relative to the control circuits of the DTE-MAU interface for MAUs without conditioning requirements. Messages used in these state diagrams are explained below:

- a) *positive\_disable*. Activates the positive means provided in the MAU transmitter to prevent interference with the trunk coaxial medium.
- b) *enable\_driver*. Activates the path employed during normal operation to cause the MAU transmitter to impress data onto the trunk coaxial medium.
- c) *disable\_driver*. Deactivates the path employed during normal operation to cause the MAU transmitter to impress data onto the trunk coaxial medium.
- d) *no\_collision*. Signifies that the condition of multiple transmitters simultaneously active on the trunk coaxial medium does not exist.
- e) *collision*. Signifies that the condition of multiple transmitters simultaneously active on the trunk coaxial medium does exist.
- f) *not\_positive\_disable*. Deactivates the positive means provided in the MAU transmitter to prevent interference with the trunk coaxial medium.

When no state is asserting the message *signal\_quality\_error*, the message *MAU\_input\_idle* is sent.

## 8.3 MAU–medium electrical characteristics

### 8.3.1 MAU-to-coaxial cable interface

The following subclauses describe the interface between the MAU and the coaxial cable. Negative current is defined as current into the MAU (out of the center conductor of the cable).

#### 8.3.1.1 Input impedance

The shunt capacitance presented to the coaxial cable by the MAU circuitry (not including the means of attachment to the coaxial cable) is recommended to be no greater than 2 pF. The resistance to the coaxial cable shall be greater than 100 k $\Omega$ .

**The total capacitive load due to MAU circuitry and the mechanical connector as specified in 8.5.3.2 shall be no greater than 4 pF.**

These conditions shall be met in the power-off and power-on, not transmitting states (over the frequencies BR/2 to BR).

The magnitude of the reflection from a MAU shall not be more than that produced by a 4 pF capacitance when measured by both a 25 ns rise time and 25 ns fall time waveform. This shall be met in both the power on and power off, not transmitting states.



### 8.3.1.2 Bias current

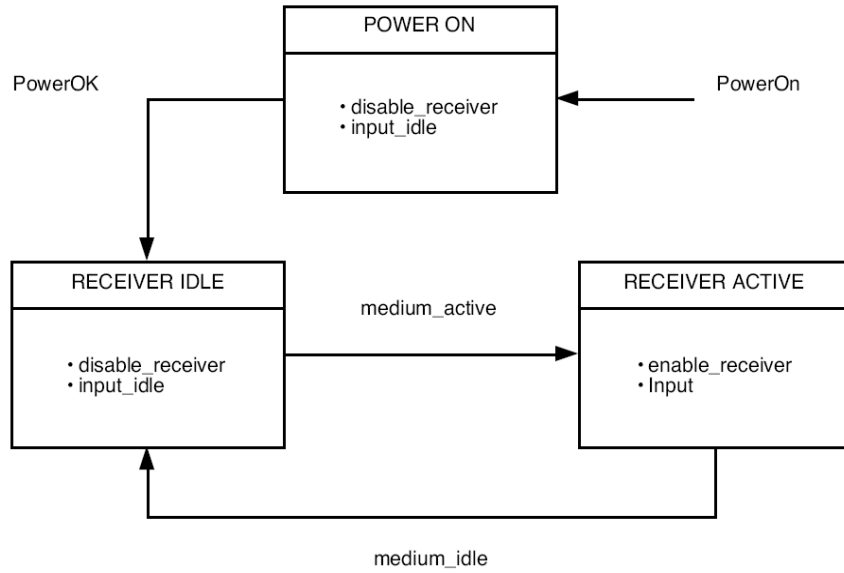
The MAU shall draw (from the cable) between  $+2 \mu\text{A}$  and  $-25 \mu\text{A}$  in the power-off and the power-on, not transmitting states.

### 8.3.1.3 Coaxial cable signaling levels

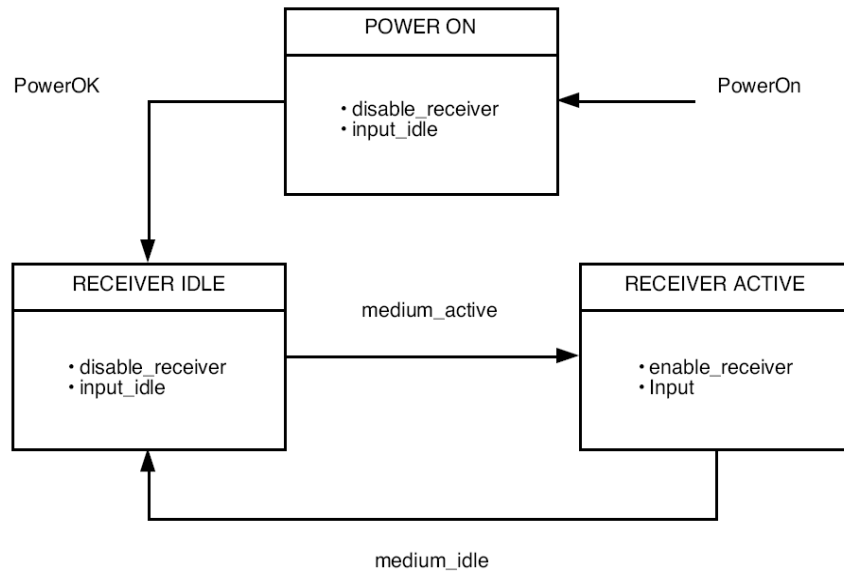
The signal on the coaxial cable due to a single MAU as measured at the MAU transmitter output is composed of an ac component and an offset component. Expressed in terms of current immediately adjacent to the MAU connection (just prior to splitting the current flow in each direction) the signal has an offset component (direct current including the effects of timing distortion) of from  $-37 \text{ mA}$  minimum to  $-45 \text{ mA}$  maximum and an ac component from  $+28 \text{ mA}$  up to the offset value.

The current drive limit shall be met even in the presence of one other MAU transmitter. A MAU shall be capable of maintaining at least  $2.2 \text{ V}$  of average dc level on the coaxial cable in the presence of two or more other MAUs transmitting concurrently. The MAU shall, in addition, sink no more than  $\pm 250 \mu\text{A}$  when the voltage on the center conductor of the cable drops to  $-10 \text{ V}$  when the MAU is transmitting.

The MAU shall sink no more than  $-25 \mu\text{A}$  when the voltage on the center conductor of the cable drops to  $-7 \text{ V}$  when the MAU is transmitting.

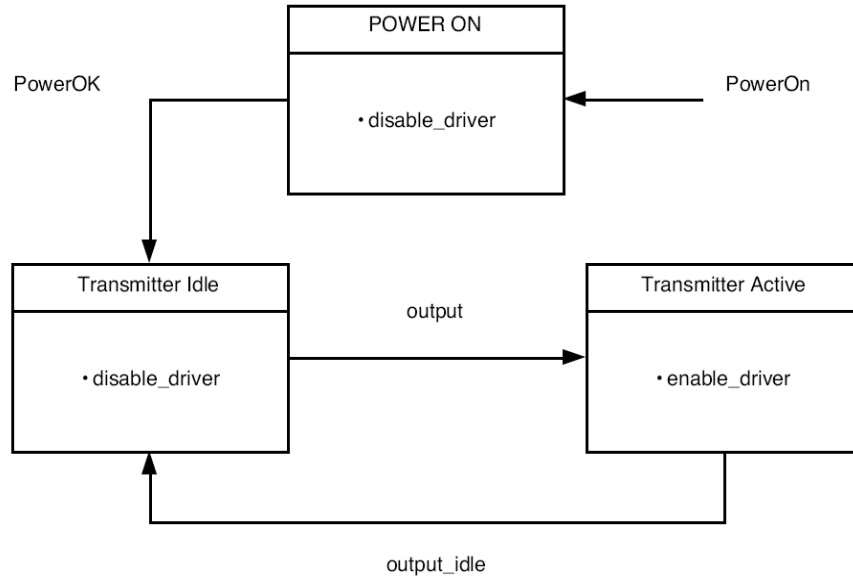


a) Receive function state diagram

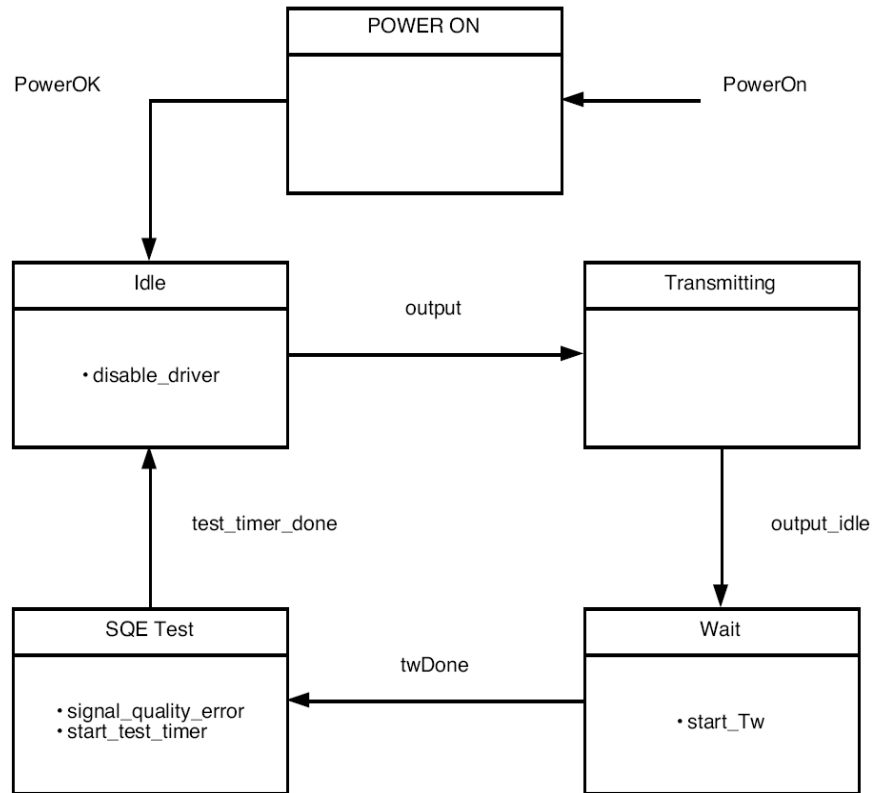


b) Collision Presence function state diagram

Figure 8–2—Interface function: Simple MAU without isolate capability

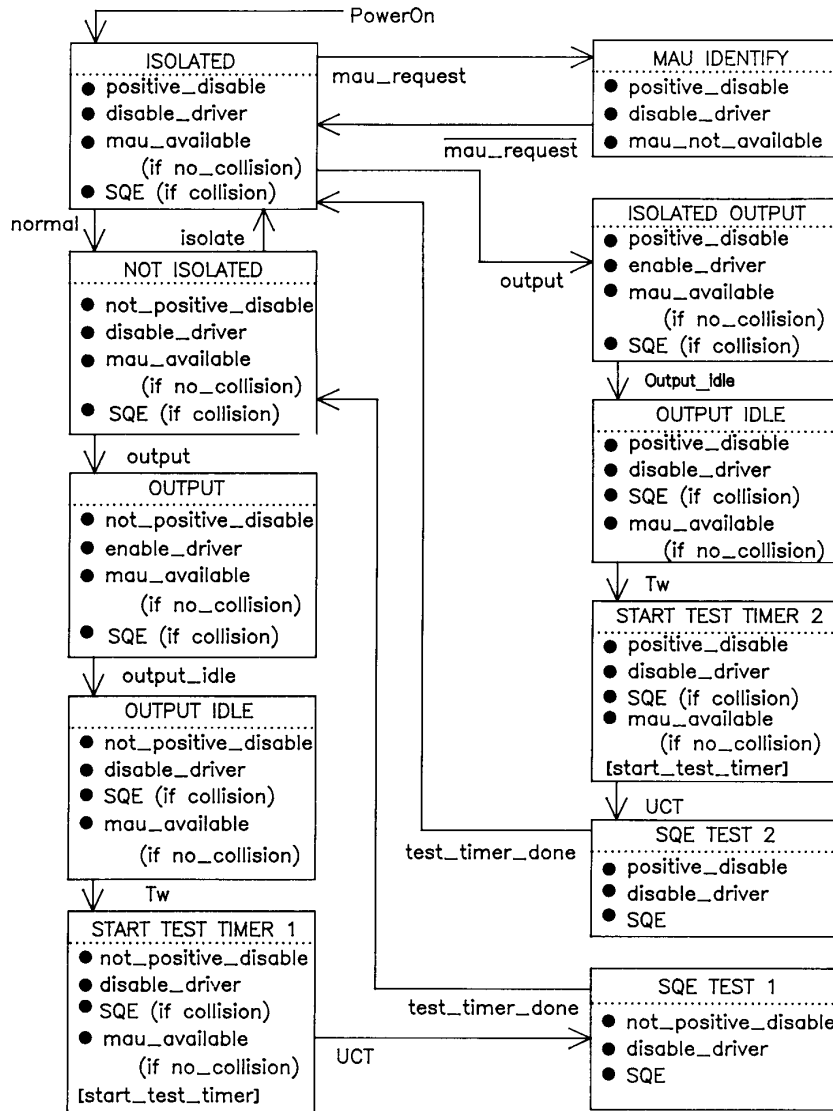


**c) Transmit function state diagram**



**d) SQE test state diagram**

**Figure 8-2—(Continued)**  
**Interface function: Simple MAU without isolate capability**



NOTE: UCT = unconditional transition  
Tw = wait time, see 8.2.1.1

Figure 8-3—Interface function: Simple MAU with isolate capability

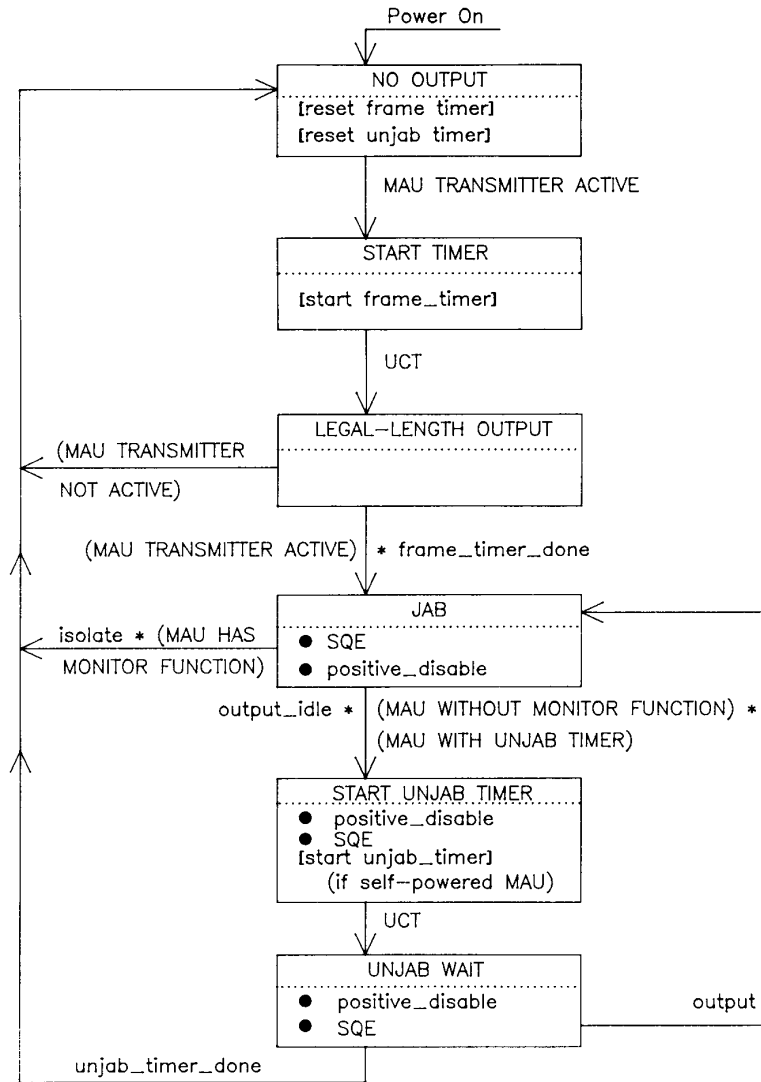


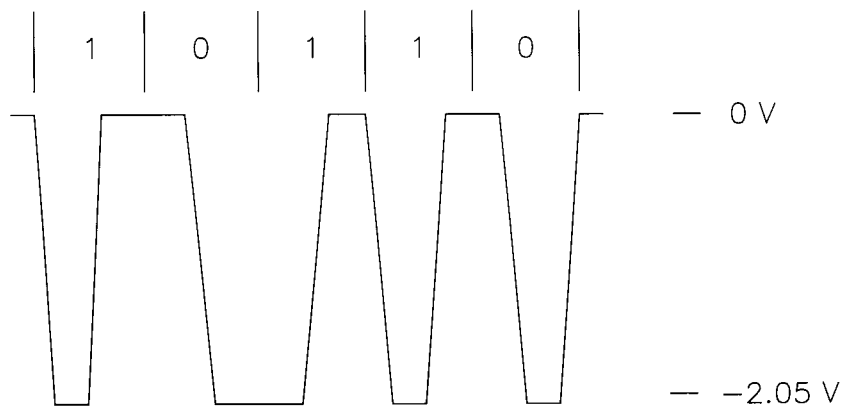
Figure 8-4—Jabber function

The actual current measured at a given point on the cable is a function of the transmitted current and the cable loss to the point of measurement. Negative current is defined as current out of the center conductor of the cable (into the MAU). The 10–90% rise/fall times shall be  $25 \text{ ns} \pm 5 \text{ ns}$  at 10 Mb/s. The rise and fall times shall match within 2 ns. Figure 8–5 and Figure 8–6 shows typical waveforms present on the cable. Harmonic content generated from the BR fundamental periodic input shall meet the following requirements:

- 2nd and 3rd Harmonics: at least 20 dB below fundamental
- 4th and 5th Harmonics: at least 30 dB below fundamental
- 6th and 7th Harmonics: at least 40 dB below fundamental
- All higher Harmonics: at least 50 dB below fundamental

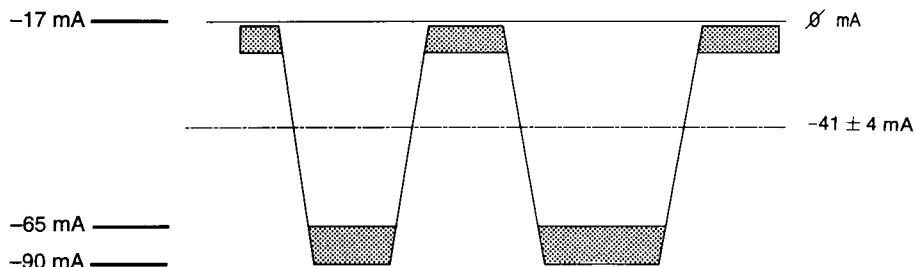
NOTE—Even harmonics are typically much lower.

The above specifications concerning harmonics cannot be satisfied by a square-wave with a single-pole filter, nor can they be satisfied by an output waveform generator employing linear ramps without additional waveshaping. The signals as generated from the encoder within PLS shall appear on the coaxial cable without any inversions (see Figure 8–6).



- NOTES: (1) Voltages given are nominal, for a single transmitter  
 (2) Rise and fall time is 25 ns nominal at 10 Mb/s rate  
 (3) Voltages are measured on terminated coaxial cable adjacent to transmitting MAU  
 (4) Manchester coding

**Figure 8–5—Typical coaxial trunk cable signal waveform**



**Figure 8–6—Recommended driver current signal levels**

### 8.3.1.4 Transmit output levels symmetry

Signals received from the AUI DO circuit shall be transmitted onto the coaxial cable with the characteristics specified in 8.3.1.3. Since the coaxial cable proceeds in two directions from the MAU, the current into the MAU is nominally twice the current measured on the coaxial cable.

The output signal of a MAU meeting this specification shall exhibit edge jitter of no more than 2.5 ns into a  $25\ \Omega \pm 1\%$  resistor substituted for the connection to the coaxial cable when the DO circuit into the MAU is driven through a zero length AUI cable with pseudorandom Manchester encoded binary data from a data generator that exhibits no more than 0.5 ns of edge jitter on half bit cells of exactly 1/2 BT whose output meets the specifications of 7.4.1.1 through 7.4.1.5. The above specified component is not to introduce more than 2 ns of edge jitter into the system.

The MAU shall not transmit a negative going edge after cessation of the CD output data stream on DO or before the first edge of the next frame on the DO circuit.

### 8.3.1.5 Collision detect thresholds

Receive mode collision detection indicates that a nontransmitting MAU has the capability to detect collisions when two or more MAUs are transmitting simultaneously. For receive mode collision detection, the MAU's collision detection threshold shall be within the range  $-1448\ \text{mV}$  to  $-1590\ \text{mV}$ . The actual dc voltage on the cable during a noncollision transmission has a maximum value of  $-1293\ \text{mV}$ . The lower threshold limit of  $-1448\ \text{mV}$  allows 55 mV for sending end overshoot during preamble and filter impulse response during the remainder of the packet. These limits take account of up to 12% collision detect filter impulse response. If a specific filter implementation has a higher value of impulse response, the lower threshold limit of 1448 mV shall be replaced by  $1293\ \text{mV} \times [1 + \text{impulse response}]$ .

All MAUs are required to implement receive mode collision detection.

NOTE—The above threshold limits are measured at the coaxial cable center conductor with respect to the shield at the MAU connector. The MAU designer must take into account circuit offsets, low-frequency noise (for example, 50 Hz, 60 Hz), and 5 MHz ripple at the filter output in determining the actual internal threshold value and its tolerance.

## 8.3.2 MAU electrical characteristics

### 8.3.2.1 Electrical isolation

The MAU must provide isolation between the AUI cable and the coaxial trunk cable. This isolation shall withstand at least one of the following electrical strength tests:

- a) 1500 V rms at 50 Hz to 60 Hz for 60 s, applied as specified in 5.3.2 of IEC 60950: 1991.
- b) 2250 Vdc for 60 s, applied as specified in 5.3.2 of IEC 60950: 1991.
- c) A sequence of ten 2400 V impulses of alternating polarity, applied at intervals of not less than 1 s. The shape of the impulses shall be 1.2/50  $\mu\text{s}$  (1.2  $\mu\text{s}$  virtual front time, 50  $\mu\text{s}$  virtual time of half value), as defined in IEC 60060.

There shall be no isolation breakdown, as defined in 5.3.2 of IEC 60950: 1991, during the test. The resistance after the test shall be at least 2 M $\Omega$ , measured at 500 Vdc. In addition, the isolation impedance between the DTE and the coaxial cable shield shall be less than 15  $\Omega$  between 3 MHz and 30 MHz.

#### CAUTION

The current electrical isolation requirement is a change that was incorporated into IEEE Std 802.3-1996. Older editions of IEEE Std 802.3 had a significantly lower isolation requirement.

### **8.3.2.2 Power consumption**

The current drawn by the MAU shall not exceed 0.5 A as powered by the AUI source. The MAU shall be capable of operating from all possible voltage sources as supplied by the DTE through the resistance of all permissible AUI cables. The MAU shall not disrupt the trunk coaxial medium should the DTE power source fall below the minimum operational level under abnormal MAU load conditions.

The MAU shall be labeled externally to identify the maximum value of current required by the device at any specified input voltage.

### **8.3.2.3 Reliability**

The MAU shall be designed to provide an MTBF of at least 1 million hours of continuous operation without causing communication failure among other stations attached to the local network medium. Component failures within the MAU electronics should not prevent communication among other MAUs on the coaxial cable. Connectors and other passive components comprising the means of connecting the MAU to the coaxial cable shall be designed to minimize the probability of total network failure.

It should be noted that a fault condition that causes a MAU to draw in excess of 2 mA may cause communication failure among other stations.

### **8.3.3 MAU–DTE electrical characteristics**

The electrical characteristics for the driver and receiver components connected to the branch cable within the MAU shall be identical to those as specified in Clause 7 of this standard.

### **8.3.4 MAU–DTE mechanical connection**

The MAU shall be provided with a 15-pin male connector as specified in detail in the AUI specification, Clause 7.

## **8.4 Characteristics of the coaxial cable**

The trunk cable is of constant impedance, coaxial construction. It is terminated at each end by a terminator (see 8.5.2), and provides the transmission path for MAU device connection. Coaxial cable connectors are used to make the connection from the cable to the terminators, and between cable sections (if needed). The cable has various electrical and mechanical requirements that shall be met to ensure proper operation.

### **8.4.1 Coaxial cable electrical parameters**

#### **8.4.1.1 Characteristic impedance**

The average characteristic cable impedance shall be  $50 \pm 2 \Omega$ , measured at 10 MHz according to IEC 60096-1: 1986 and Amd. 2: 1993. Periodic variations in impedance along a single piece of cable may be up to  $\pm 3 \Omega$  sinusoidal centered around the average value, with a period of less than 2 m.

NOTE—If the requirements of 8.4.2.1.1 item b), 8.4.2.1.2, 8.4.2.1.3, and 8.4.2.1.4 item b) are met, then it is expected that the characteristic impedance periodicity requirement shall be considered met.

#### **8.4.1.2 Attenuation**

The attenuation of a 500 m cable segment shall not exceed 8.5 dB (17 dB/km) measured with a 10 MHz sine wave, nor 6.0 dB (12 dB/km) measured with a 5 MHz sine wave.



### 8.4.1.3 Velocity of propagation

The minimum required velocity of propagation is  $0.77 c$ .

### 8.4.1.4 Edge jitter, untapped cable

Untapped coaxial cable meeting this specification shall exhibit edge jitter of no more than 8.0 ns in either direction at the receiving end when 500 m of the cable is terminated at both ends with terminators meeting the impedance requirements of 8.5.2.1 and is driven at one end with pseudorandom Manchester-encoded binary data from a data generator that exhibits no more than 1.0 ns of edge jitter in either direction on half bit cells of exactly  $1/2 BT$  and whose output meets the specifications of 8.3.1.3 except that the rise time of the signal must be  $30 \text{ ns} + 0, - 2 \text{ ns}$ , and no offset component in the output current is required. This test shall be conducted in a noise-free environment. The above specified component is not to introduce more than 7 ns of edge jitter into the system.

### 8.4.1.5 Transfer impedance

The coaxial cable medium shall provide sufficient shielding capability to minimize its susceptibility to external noise and also to minimize the generation of interference by the medium and related signals. While the cable construction is not mandated, it is necessary to indicate a measure of performance expected from the cable component. A cable's EMC performance is determined, to a large extent, by the transfer impedance value of the cable. See reference [B49].

The transfer impedance of the cable shall not exceed the values shown in Figure 8–7 as a function of frequency.

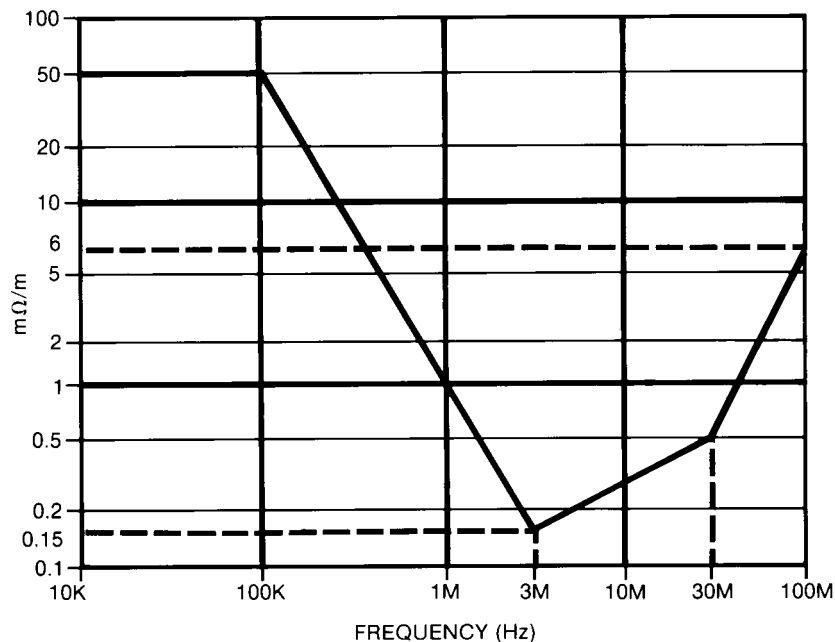


Figure 8–7—Maximum coaxial cable transfer impedance

### 8.4.1.6 Cable dc loop resistance

The sum of the center conductor resistance plus the shield resistance, measured at  $20^\circ \text{C}$ , shall not exceed  $10 \text{ m}\Omega/\text{m}$ .

## 8.4.2 Coaxial cable properties

### 8.4.2.1 Mechanical requirements

The cable used should be suitable for routing in various environments, including but not limited to, dropped ceilings, raised floors, cable troughs, and throughout open floor space. The jacket shall provide insulation between the cable sheath and any building structural metal. Also, the cable shall be capable of accepting coaxial cable connectors, described in 8.5. The cable shall conform to the following requirements.

#### 8.4.2.1.1 General construction

- a) The coaxial cable shall consist of a center conductor, dielectric, shield system, and overall insulating jacket.
- b) The concentricity (for example, positional relationship between center conductor to shield system and outer jacket) of the coaxial cable elements shall be greater than 92% as measured in accordance with the following general configuration:

$$\frac{(\text{jacket radius}) - (\text{center offset})}{\text{jacket radius}} \times 100 \geq 92\%$$

It is assumed that the offset and radius values are worst case at any point within the measured system.

- c) The coaxial cable jacket, shield system, and dielectric material shall be pierceable either by means of the connector type specified in 8.5.3.2 or by an external core tool. Overall cable system pierceability (the ability of a tap probe to pierce the jacket, shields, and dielectric cable system without substantial dielectric deformation and without causing a short circuit between center conductor and shield system) is a vital parameter affecting tap connection reliability.

Pierceability of the cable system can be measured in terms of the probe's load versus displacement signature. A pierceable cable exists where the displacement is  $\geq 1.52$  mm (0.06 in) between rupture (piercing) of the shield system and contact with the center conductor.

- d) The coaxial cable shall be sufficiently flexible to support a bend radius of 254 mm (10 in).

#### 8.4.2.1.2 Center conductor

The center conductor shall be 2.17 mm  $\pm$  0.013 mm (0.0855 in  $\pm$  0.0005 in) diameter tinned or plain solid copper.

#### 8.4.2.1.3 Dielectric material

The dielectric may be of any type provided the conditions of 8.4.1.2, 8.4.1.3, and 8.4.2.1.1 item d) are met.

#### 8.4.2.1.4 Shielding system

- a) The shielding system may contain both braid and foil elements sufficient to meet the transfer impedance of 8.4.1.5 and the EMC specifications of 8.7.2.
- b) The inside diameter of the innermost shield shall be 6.00 mm (0.236 in) minimum.
- c) The outside diameter of the outermost shield shall be 8.00 mm  $\pm$  0.40 mm (0.315 in  $\pm$  0.016 in).
- d) The outermost shield shall be a tinned copper braid. The percent coverage shall be sufficient to meet 8.4.1.5, 8.4.1.6, 8.5.3.2.3, and 8.7.2.

#### 8.4.2.1.5 Overall jacket

- a) Any one of several jacket materials shall be used provided the specifications of 8.4.1 and 8.4.2 are met.

- b) Either of two jacket dimensions may be used for the two broad classes of materials, provided the specification of 8.4.2.1.1 are met:
  - 1) Polyvinyl Chloride (for example, PVC) or equivalent having an OD of  $10.3 \text{ mm} \pm 0.25 \text{ mm}$  ( $0.406 \text{ nominal} \pm 0.010 \text{ in}$ ).
  - 2) Fluoropolymer (for example, FEP, E-CTFE) or equivalent having an OD of  $9.525 \text{ mm} \pm 0.254 \text{ mm}$  ( $0.375 \text{ nominal} \pm 0.010 \text{ in}$ ).

The cable shall meet applicable flammability and smoke criteria and local and national codes for the installed environment. See 8.7.4. Different types of cable sections (for example, polyvinyl chloride and fluoropolymer dielectric) may be interconnected, while meeting the sectioning requirements of 8.6. See references [B20] and [B55].

#### 8.4.2.2 Jacket marking

The cable jacket shall be marked in a color contrasting with the background color of the jacket. The markings shall be spaced at  $2.5 \text{ m} \pm 5 \text{ cm}$  regularly along the entire length of the cable. It is permissible for the 2.5 m spacing to be interrupted at discontinuities between cable sections joined by connectors. (See 8.6.2.2 for MAU placement rules that mandate cable markings.) It is recommended that the base color of the jacket itself be a bright color (for example, yellow) other than that normally used for power mains.

#### 8.4.3 Total segment dc loop resistance

The sum of the center conductor, connectors, and shield resistance shall not exceed  $5 \Omega$  total per segment.

Each in-line connector pair or MAU shall be no more than  $10 \text{ m}\Omega$ . Use of these components reduces the overall allowable segment length accordingly. Values given above are at  $20 \text{ }^\circ\text{C}$ . For temperature variations, cable length shall be adjusted accordingly such that the  $5 \Omega$  total is not exceeded.

If a trunk coaxial cable segment consists of several cable sections, then all connectors and internal resistance of the shield and center conductor shall be included in the loop resistance measurement.

### 8.5 Coaxial trunk cable connectors

The trunk coaxial medium requires termination and may be extended or partitioned into sections. Devices to be attached to the medium as MAUs require a means of connection to the medium. Two basic connector types provide the necessary connection means:

- a) Standard Type N connectors (IEC 60169-16)
- b) A coaxial “tap” connector

All Type N connectors shall be of the  $50 \Omega$  constant impedance type. Since the frequencies present in the transmitted data are well below UHF range (being band-limited to approximately 20 MHz), high-quality versions of the connectors are not required (but are recommended).

All of the coaxial tap connectors shall follow the requirements as defined in 8.5.3.

#### 8.5.1 Inline coaxial extension connector

All coaxial cables shall be terminated with the Type N plug connectors. A means shall be provided to ensure that the connector shell (which connects to the cable sheath) does not make contact with any building metal or other unintended conductor. An insulating sleeve or boot slipped over the connector at installation time is suitable.

Inline coaxial extensions between two sections of coaxial cable shall be made with a pair of Type N receptacle connectors joined together to form one “barrel.” An insulating sleeve or boot shall also be provided with each barrel assembly.

## **8.5.2 Coaxial cable terminator**

### **8.5.2.1 Termination**

Coaxial cable terminators are used to provide a termination impedance for the cable equal in value to its characteristic impedance, thereby minimizing reflection from the ends of the cables. Terminators shall be packaged within an inline female receptacle connector. The termination impedance shall be  $50 \Omega \pm 1\%$  measured from 0 MHz to 20 MHz, with the magnitude of the phase angle of the impedance not to exceed  $5^\circ$ . The terminator power rating shall be 1 W or greater.

### **8.5.2.2 Earthing**

Either the coaxial cable terminator or inline extension connector provides a convenient location for meeting the earth grounding requirement of 8.6.2.3. It is recommended that a ground lug with current rating of at least 1500 ampacity be provided on one of the two terminators or on one extension connector used within a cable segment.

NOTE 1—A single ground return lug on an inline connector located in the center of the cable transmission system may be used to satisfy this requirement.

NOTE 2—Alternatively, terminators might be supplied in pairs, one with and one without the ground lug connection point.

## **8.5.3 MAU-to-coaxial cable connection**

A means shall be provided to allow for attaching a MAU to the coaxial cable. The connection shall not disturb the transmission line characteristics of the cable significantly; it shall present a predictably low shunt capacitance, and therefore a negligibly short stub length. This is facilitated by the MAU being located as close to its cable connection as possible; the MAU and connector are normally considered to be one assembly. Long (greater than 30 mm) connections between the coaxial cable and the input of the MAU jeopardize this objective.

Overall system performance is dependent largely on the MAU-to-coaxial cable connection being of low shunt capacitance.

If the design of the connection is such that the coaxial cable is to be severed to install the MAU, the coaxial cable segment shall still meet the sectioning requirements of 8.6.2.1. Coaxial connectors used on a severed cable shall be Type N, as specified in 8.5.1.

The Type N connectors selected should be of high quality (that is, low contact resistance) to minimize the impact on system performance.

If the design of the connection is such that the piercing tap connector is to be used without severing the cable, then the tap connector and cable assembly shall conform to the mechanical and electrical requirements as defined throughout 8.5.3.1 and 8.5.3.2.

### **8.5.3.1 Electrical requirements**

Requirements for the coaxial tap connector are as follows:

- a) *Capacitance*: 2 pF nominal connector loading measured at 10 MHz.

NOTE—**Total** capacitance of tap and active circuitry connected directly shall be no greater than 4 pF. Specific implementations may allocate capacitance between tap and circuitry as deemed appropriate.

- b) *Contact resistance* (applies to center conductor and shield contacts): 50 mΩ maximum for both shield and center conductor over useful connector lifetime.
- c) *Contact material*: surface material on signal probe or shield sufficient to meet contact resistance requirements in environment and over time.
- d) *Voltage rating*: 600 V dc or ac rms maximum.
- e) *Insulation*: dc leakage resistance of tap housing shall be higher than 1 GΩ between braid and external conductors in the normal operating environment.
- f) *Probe current rating*: 0.1 A per contact (probe and shield).
- g) *Shield current rating*: 1 A surge for 1 s.

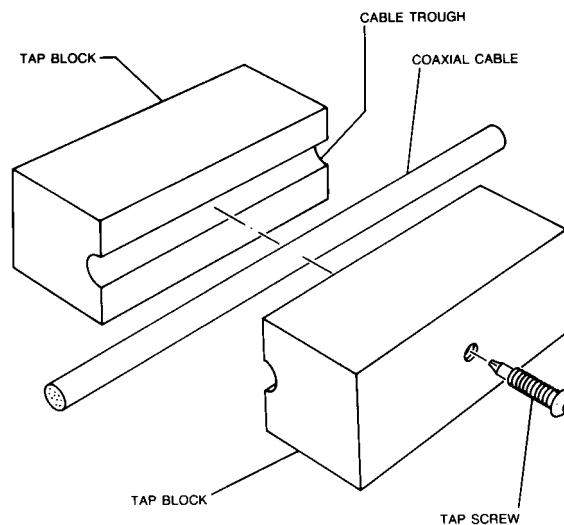
### 8.5.3.2 Mechanical requirements

#### 8.5.3.2.1 Connector housing

Shielding characteristics: > 40 dB at 50 MHz.

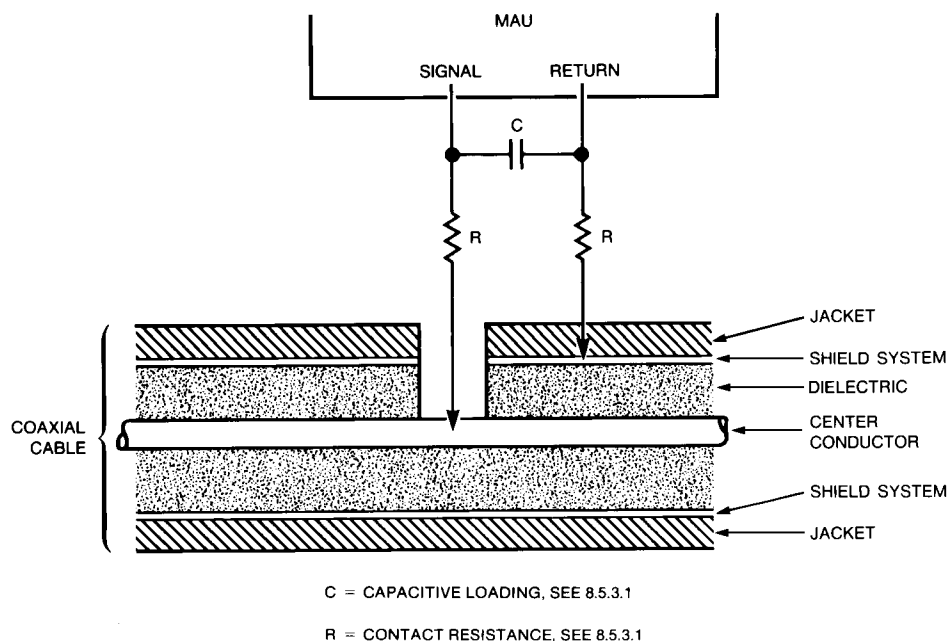
#### 8.5.3.2.2 Contact reliability

Overall performance of the LAN system depends to a large extent on the reliability of the coaxial cable medium and the connection to that medium. Tap connection systems should consider the relevant electrical and mechanical parameters at the point of electrical connection between tap probe and cable center conductor to ensure that a reliable electrical contact is made and retained throughout the useful life of these components. It is recommended that some means be provided to ensure relatively constant contact loading over time, with creep, in temperature, and typical environment. Typical coaxial tap connector configurations are shown in Figure 8–8 and Figure 8–9. See references [B3], [B1], and [B2].



NOTE: **Tutorial only** and **not** part of specification

**Figure 8–8—Coaxial tap connector configuration concepts**



**Figure 8-9—Typical coaxial tap connection circuit**

### 8.5.3.2.3 Shield probe characteristics

The shield probe shall penetrate the cable jacket and outer layer(s) of the shield system to make effective capture of the outer braid (pick 2 or more typical strands).

## 8.6 System considerations

### 8.6.1 Transmission system model

The maximum configuration for the physical transmission system is as follows:

- a) A trunk coaxial cable, terminated in its characteristic impedance at each end, constitutes a coaxial cable segment. A coaxial cable segment may contain a maximum of 500 m of coaxial cable and a maximum of 100 MAUs. The propagation velocity of the coaxial cable is assumed to be 0.77 c minimum ( $c = 300\,000$  km/s). The maximum end-to-end propagation delay for a coaxial cable segment is 2165 ns.
- b) Repeater sets are required for segment interconnection. Repeater sets occupy MAU positions on coaxial cable segments and count toward the maximum number of MAUs on a coaxial cable segment. Repeater sets may be located in any MAU position on a coaxial cable segment.
- c) The repeater unit specified in Clause 9 provides the means for connecting 10 Mb/s baseband segments into a CSMA/CD network. The proper operation of a CSMA/CD network requires network size to be limited to control round-trip propagation delay to meet the requirements of 4.2.3.2.3 and 4.4.2, and the number of repeaters between any two DTEs to be limited in order to limit the shrinkage of interpacket gap as it travels through the network. Configuration rules, which ensure that these limits are not exceeded, are given in Clause 13.

## 8.6.2 Transmission system requirements

### 8.6.2.1 Cable sectioning

The 500 m maximum length coaxial cable segment need not be made from a single, homogeneous length of cable. The boundary between two cable sections (joined by coaxial connectors: two male plugs and a barrel) represents a signal reflection point due to the impedance discontinuity caused by the batch-to-batch impedance tolerance of the cable. Since the worst-case variation from  $50\ \Omega$  is  $2\ \Omega$ , a possible worst-case reflection of 4% may result from the joining of two cable sections. The configuration of long cable segments (up to 500 m) from smaller sections must be made with care. The following *recommendations* apply, and are given *in order of preference*:

- a) If possible, the total segment should be made from one homogeneous (no breaks) cable. This is feasible for short segments, and results in minimal reflections from cable impedance discontinuities.
- b) If cable segments are built up from smaller sections, it is recommended that all sections come from the same manufacturer and lot. This is equivalent to using a single cable, since the cable discontinuities are due to extruder limitations, and not extruder-to-extruder tolerances. There are no restrictions in cable sectioning if this method is used. However, if a cable section in such a system is later replaced, it shall be replaced either with another cable from the same manufacturer and lot, or with one of the standard lengths described below.
- c) If uncontrolled cable sections must be used in building up a longer segment, the lengths should be chosen so that reflections, when they occur, do not have a high probability of adding in phase. This can be accomplished by using lengths that are odd integral multiples of a half wavelength in the cable at 5 MHz; this corresponds to using lengths of 23.4 m, 70.2 m, and 117 m ( $\pm 0.5$  m) for all sections. These are considered to be the standard lengths for all cable sections. Using these lengths exclusively, any mix or match of cable sections may be used to build up a 500 m segment without incurring excessive reflections.

NOTE—If cable segments are to be added to existing installations, then care shall be taken (explicit physical or TDR measurements) to ensure that no more than a 500 m cable segment results.

- d) As a last resort, an arbitrary configuration of cable sections may be employed, if it has been confirmed by analysis or measurement that the worst-case signal reflection due to the impedance discontinuities at any point on the cable does not exceed 7% of the incident wave when driven by a MAU meeting these specifications.

### 8.6.2.2 MAU placement

MAU components and their associated connections to the cable cause signal reflections due to their noninfinite bridging impedance. While this impedance shall be implemented as specified in Clause 7, placement of MAUs along the coaxial cable must also be controlled to ensure that reflections from the MAU do not add in phase to a significant degree.

Coaxial cables marked as specified in 8.4.2.2 have marks at regular 2.5 m spacing; a MAU shall only be placed at a mark on the cable. This guarantees both a minimum spacing between MAUs of 2.5 m, and controlling the relative spacing of MAUs to ensure nonalignment on fractional wavelength boundaries.

The total number of MAUs on a cable segment shall not exceed 100.

### 8.6.2.3 Trunk cable system grounding

The *shield conductor* of each coaxial cable segment shall make electrical contact with an *effective earth reference* (see [B14], Articles 250 and 800) *at one point and shall not make electrical contact with earth elsewhere* on such objects as building structural metal, ducting, plumbing fixture, or other unintended

conductor. Insulators may be used to cover any coaxial connectors used to join cable sections and terminators, to ensure that this requirement is met. A sleeve or boot attached at installation time is acceptable.

This specification is intended for use within (intraplant) buildings. Applications requiring interplant connections by way of external (outdoors) means may require special consideration beyond the scope of the standard.

The sheath conductor of the AUI cable shall be connected to the earth reference or chassis of the DTE.

### **8.6.3 Labeling**

It is recommended that each MAU (and supporting documentation) be labeled in a manner visible to the user with at least these parameters:

- a) Data rate capability in megabits per second
- b) Power level in terms of maximum current drain
- c) Safety warning (for example, shock hazard)

## **8.7 Environmental specifications**

### **8.7.1 General safety requirements**

All stations meeting this standard shall conform to IEC 60950: 1991.

### **8.7.2 Network safety requirements**

This subclause sets forth a number of recommendations and guidelines related to safety concerns, the list is neither complete nor does it address all possible safety issues. The designer is urged to consult the relevant local, national, and international safety regulations to ensure compliance with the appropriate standards. References [B14] and [B26] provide additional guidance.

LAN trunk cable systems as described in this standard are subject to at least four direct electrical safety hazards during their use. These hazards are

- a) Direct contact between local network components and power or lighting circuits.
- b) Static charge buildup on local network cables and components.
- c) High-energy transients coupled onto the local network cabling system.
- d) Potential differences between safety grounds to which various network components are connected.

These electrical safety hazards, to which all similar cabling systems are subject, should be alleviated properly for a local network to perform properly. In addition to provisions for properly handling these faults in an operational system, special measures must be taken to ensure that the intended safety features are not negated during installation of a new network or during modification of an existing network.

Proper implementation of the following provisions will greatly decrease the likelihood of shock hazards to persons installing and operating the LAN.

#### **8.7.2.1 Installations**

Sound installation practice, as defined by applicable local codes and regulations, shall be followed in every instance in which such practice is applicable.



### 8.7.2.2 Grounding

The shield of the trunk coaxial cable shall be effectively grounded at only one point along the length of the cable. Effectively grounded means permanently connected to earth through a ground connection of sufficiently low impedance and having sufficient ampacity to prevent the building up of voltages that may result in undue hazard to connected equipment or to persons.

### 8.7.2.3 Safety

All portions of the trunk cabling system that are at the same potential as the trunk cable shall be insulated by adequate means to prevent their contact by either persons or by unintended conductors or grounds. The insulation employed shall provide the same or greater dielectric resistance to current flow as the insulation required between the outermost shield of the trunk cable and the above-mentioned unintended conductors. The use of insulating boots is permitted, provided that such boots (or sleeves) are mechanically and electrically equivalent to the trunk cable outer insulation characteristics and are not removed easily (that is, they shall prevent inadvertent removal by a system operator).

The MAU shall be so designed that the provisions of 8.7.2.3 and 8.7.2.4 are not defeated if the connector affixing the AUI cable to the MAU is removed.

Portions of the trunk cabling system that may become live during the dissipation of a high-energy transient by the cabling system shall also be insulated as described in 8.7.2.3.

### 8.7.2.4 Breakdown path

MAUs meeting this standard should provide a controlled breakdown path that will shunt high-energy transients to an effective ground either through a separate safety ground connection or through the overall shield of the branch cable. The breakdown voltage of this controlled breakdown path must meet the isolation requirements for the MAU specified in 8.3.2.1.

### 8.7.2.5 Isolation boundary

The isolation boundary between the branch cable and trunk cable specified in 8.3.2.1 shall be maintained to properly meet the safety requirements of this standard.

#### WARNING

It is assumed that the DTE equipment is properly earthed and not left floating or serviced by “doubly insulated ac power distribution system.” The use of floating or insulated DTEs is beyond the scope of this standard.

### 8.7.2.6 Installation and maintenance guidelines

- a) When exposing the shield of the trunk coaxial cable for any reason, care shall be exercised to ensure that the shield does not make electrical contact with any unintended conductors or grounds. Personnel performing the operation should not do so if dissipation of a high energy transient by the cabling system is likely during the time the shield is to be exposed. Personnel should not contact both the shield and any grounded conductor at any time.
- b) Before breaking the trunk coaxial cable for any reason, a strap with ampacity equal to that of the shield of the coaxial cable shall be affixed to the cable shield in such a manner as to join the two pieces and to maintain continuity when the shield of the trunk cable is severed. This strap shall not be removed until after normal shield continuity has been restored.
- c) At no time should the shield of any portion of the coaxial trunk cable to which an MAU or MAUs are attached be permitted to float without an effective ground connection. If a section of floating

cable is to be added to an existing cable system, the installer shall take care not to complete the circuit between the shield of the floating cable section and the grounded cable section through body contact.

- d) The installation instructions for network components shall contain language which familiarizes the installer with the cautions mentioned in the above paragraphs.
- e) Network components shall contain prominent warning labels that refer installers and service personnel to the safety notes in the installation instructions.

### **8.7.3 Electromagnetic environment**

#### **8.7.3.1 Susceptibility levels**

Sources of interference from the environment include electromagnetic fields, electrostatic discharge, transient voltages between earth connections, and similar interference. Multiple sources of interference may contribute to voltage buildup between the coaxial cable and the earth connection of a DTE.

The physical channel hardware shall meet its specifications when operating in either of the following conditions:

- a) Ambient plane wave field of 2 V/m from 10 kHz through 30 MHz, 5 V/m from 30 MHz through 1 GHz.

NOTE—Levels typically 1 km from broadcast stations.

- b) Interference voltage of 1 V/ns peak slope, between coaxial cable shield and DTE earth connection; for example, 15.8 V peak for a 10 MHz sine wave with a 50  $\Omega$  source resistance.

MAUs meeting this standard should provide adequate rf ground return to satisfy the referenced EMC specifications.

#### **8.7.3.2 Emission levels**

The physical MAU and trunk cable system shall comply with applicable local and national codes such as FCC Docket 20780-1980 [B30] in the USA. Equipment shall comply with local and national requirements for limitation of electromagnetic interference. Where no local or national requirements exist, equipment shall comply with CISPR 22: 1993.

#### **8.7.4 Temperature and humidity**

The MAU and associated connector/cable systems are expected to operate over a reasonable range of environmental conditions related to temperature, humidity, and physical handling such as shock and vibration. Specific requirements and values for these parameters are considered to be beyond the scope of this standard. Manufacturers are requested to indicate in the literature associated with the MAU (and on the MAU if possible) the operating environment specifications to facilitate selection, installation, and maintenance of these components. See reference [B27] for specification terminology.

#### **8.7.5 Regulatory requirements**

The design of MAU and medium components should take into consideration applicable local or national requirements. See references [B14], [B20], [B21], [B26], [B30], and Annex B for helpful resource material.

## 8.8 Protocol implementation conformance statement (PICS) proforma for Clause 8, Medium Attachment Unit and baseband medium specifications, type 10BASE5<sup>27</sup>

### 8.8.1 Overview

The supplier of a protocol implementation that is claimed to conform to Clause 8, Medium Attachment Unit and baseband medium specifications, type 10BASE5, shall complete the following PICS proforma.

A completed PICS proforma is the PICS for the implementation in question. The PICS is a statement of which capabilities and options of the protocol have been implemented. The PICS can be used for a variety of purposes by various parties, including the following:

- As a checklist by the protocol implementor, to reduce the risk of failure to conform to the standard through oversight;
- As a detailed indication of the capabilities of the implementation, stated relative to the common basis for understanding provided by the standard PICS proforma, by the supplier and acquirer, or potential acquirer, of the implementation;
- As a basis for initially checking the possibility of interworking with another implementation by the user, or potential user, of the implementation (note that, while interworking can never be guaranteed, failure to interwork can often be predicted from incompatible PICSs);
- As the basis for selecting appropriate tests against which to assess the claim for conformance of the implementation, by a protocol tester.

### 8.8.2 Abbreviations and special symbols

#### 8.8.2.1 Status symbols

The following abbreviations are used in the PICS proforma tables:

- M      mandatory
- O      optional
- O. <n>   optional, but support of at least one of the group of options labeled by the same numeral <n> is required
- X      prohibited
- <item>:   conditional-item symbol, dependent upon the support for <item>
- !      logical negation, applied to a conditional item symbol

#### 8.8.2.2 Abbreviations

- Ref      reference section

### 8.8.3 Instructions for completing the PICS proforma

#### 8.8.3.1 General structure of the PICS proforma

The structure of this PICS proforma is based on the guidelines given in ISO/IEC 9646-1: 1994 and ISO/IEC 9646-2: 1994. The first part of the PICS proforma, Implementation Identification and Protocol Summary, is

<sup>27</sup>*Copyright release for PICS proformas:* Users of this standard may freely reproduce the PICS proforma in this subclause so that it can be used for its intended purpose and may further publish the completed PICS.

to be completed as indicated with the information necessary to identify fully both the supplier and the particular MAU.

The main part of the PICS proforma is a fixed-format questionnaire. Each item is identified by an item reference in the first column; the second column contains the question to be asked or the parameter to be measured; the third column contains the reference(s) to the material that specifies the item in the main body of this standard; the fourth column records the status of the item—whether support is mandatory, optional, prohibited, or conditional—and provides space for the answers; the fifth column provides additional comments and/or value(s) for measurable parameters. The tables below group related items into separate subclauses. This satisfies the requirement of ISO/IEC 9646-2 that all PICS proforma clauses be individually identified.

A supplier wishing to submit a 10BASE5 MAU for conformance testing against this standard must fill in the column headed Support in the PICS proforma tables and submit the resulting PICS with the equipment for test. One of the boxes in this column must be checked, with Yes indicating that the implementation is intended to meet the particular mandatory or optional requirement, No indicating that the option has not been implemented (or enabled where switchable) or that the requirement is not met, or N/A indicating the item is not applicable (for example, an item that is conditional). It should be noted that any instances of No checked against a mandatory requirement will result in the implementation failing the static conformance test.

### 8.8.3.2 Additional information

Any additional information that is needed to ensure that the MAU or the coaxial cable submitted for test is configured as a 10BASE5 MAU or coaxial cable should be entered into the PIXIT (Protocol Implementation eXtra Information for Testing) document supplied by the conformance testing organization. Relevant information on 10BASE5 MAUs includes the following:

- a) Enable/disable mechanisms for SQE Test
- b) Enable/disable mechanisms for features that allow compatibility with nonstandard implementations
- c) Operational instructions for DTEs or repeaters in cases where the MAU is embedded
- d) Environmental conditions
- e) Power supply voltage range

The above list is illustrative and is neither mandatory nor exhaustive.

### 8.8.3.3 Exception information

It may occasionally happen that a supplier will wish to answer an item with mandatory or prohibited status (after any conditions have been applied) in a way that conflicts with the indicated requirement. No pre-printed answer will be found in the Support column for this. Instead, the supplier shall write the missing answer into the Support column, together with an X<i> reference to an item of Exception Information, and shall provide the appropriate rationale in the Exception item itself.

An implementation for which an Exception item is required in this way does not conform to this standard.

### 8.8.3.4 Conditional items

The PICS proforma contains a number of conditional items. These are items for which both the applicability of the item itself, and its status if it applies—mandatory, optional, or prohibited—are dependent upon whether or not certain other items are supported.

Individual conditional items are indicated by a conditional symbol of the form “<item>:<s>” in the Status column, where “<item>” is the section number and item reference that appears in the first column of the

table for some other item, and “<s>” is a status symbol, M, O, O.<n>, or X. The “!” symbol, prefixed to an item reference, means logical negation.

If the item referred to by the conditional symbol is marked as supported, the conditional item is applicable, and its status is given by “<s>”; the support column is to be completed in the usual way. Otherwise, the conditional item is not relevant and the Not Applicable (N/A) answer is to be marked.

Each item whose reference is used in a conditional symbol is indicated by an asterisk in the Item column.

## 8.8.4 Identification

### 8.8.4.1 Implementation identification

The MAU supplier shall complete the relevant fields in this section to identify the supplier and the particular MAU.

Supplier	
Contact point for queries about the PICS	
Implementation name(s) and version(s)	

### 8.8.4.2 Protocol summary

The supplier will complete this section to identify the precise protocol implemented.

Identification of protocol specification	IEEE Std 802.3-2008, Clause 8, Medium Attachment Unit and baseband medium specifications, type 10BASE5
Identification of amendments and corrigenda to this PICS proforma which have been completed as part of this PICS	
Have any Exception items been required? (The answer Yes means that the implementation does not conform to this standard.)	Yes [ ] No [ ]

Date of Statement	
-------------------	--

### 8.8.5 Global statement of conformance

The supplier must indicate below whether or not the implementation implements all the mandatory requirements. Answering No to this question indicates nonconformance to the protocol specification. Nonsupported mandatory capabilities are to be identified in the PICS, with an explanation of why the implementation is non-conforming.

This implementation meets all mandatory requirements	Yes [ ] No [ ]
--	----------------

## 8.8.6 PICS proforma tables for MAU

### 8.8.6.1 MAU compatibility

Item	Parameter	Reference	Status	Support	Value/Comment
*1	MAU intended for attachment to repeater		O	Yes [ ]No [ ]	
*2	Monitor Function supported		O	Yes [ ]No [ ]	
*3	AUI Circuit CO supported		8.8.6.1/2 :M !8.8.6.1/2 :O	N/A [ ] Yes [ ]No [ ] N/A [ ] Yes [ ]No [ ]	Required for Monitor function
4	SQE Test supported	9.4.1	8.8.6.1/1 :X !8.8.6.1/1 :M	N/A [ ] Yes [ ]No [ ] N/A [ ] Yes [ ]No [ ]	Function not performed for MAUs attached to repeaters

### 8.8.6.2 Transmit function

Item	Parameter	Reference	Status	Support	Value/Comment
1	Transmit path	8.2.1.1	M	Yes [ ]No [ ]	DO circuit to coaxial cable
2	Transmit signal polarity	8.2.1.1	M	Yes [ ] No [ ]	DO A positive relative to DO B causes more positive voltage on the coaxial medium
3	Start-up bit loss (DO to coaxial cable)	8.2.1.1	M	Yes [ ]No [ ]	2 bits max
4	Transmit settling time	8.2.1.1	M	Yes [ ]No [ ]	Second and following bits meet amplitude and jitter specifications
5	Transmit steady-state delay	8.2.1.1	M	Yes [ ]No [ ]	1/2 bit times max
6	Start-up bit loss (DO to coaxial cable) variability	8.2.1.1	M	Yes [ ]No [ ]	2 bits max between packets separated by $\leq 96$ BT
7	No extraneous signal on the coaxial media after DO idle	8.2.1.1	M	Yes [ ]No [ ]	
8	Start collision presence state	8.2.1.1	M	Yes [ ]No [ ]	Within 0.6 $\mu$ s to 1.6 $\mu$ s after idle
9	Collision presence state duration	8.2.1.1	M	Yes [ ]No [ ]	5–15 bit times

**8.8.6.3 Receive function**

Item	Parameter	Reference	Status	Support	Value/Comment
1	Direct coupling of signal from medium to the receiver	8.2.1.2	M	Yes [ ] No [ ]	
2	AC coupling from the receiver to AUI interface	8.2.1.2	M	Yes [ ] No [ ]	
3	Start-up bit loss (coaxial cable to DI)	8.2.1.2	M	Yes [ ] No [ ]	5 bits max
4	Receive settling time	8.2.1.2	M	Yes [ ] No [ ]	Second and following bits meet jitter specifications
5	Receive steady-state delay	8.2.1.2	M	Yes [ ] No [ ]	1/2 bit times max
6	Start-up bit loss (coaxial cable to DI) variability	8.2.1.2	M	Yes [ ] No [ ]	5 bits max between packets separated by $\leq 96$ BT
7	Receive signal polarity	8.2.1.2	M	Yes [ ] No [ ]	More positive voltage on the coaxial cable will convert as DI A positive relative to DI B on the DI circuits
8	Edge jitter	8.2.1.2	M	Yes [ ] No [ ]	MAU receiver + cable introduce $\leq 6$ ns
9	Receive function while transmitting	8.2.1.2	M	Yes [ ] No [ ]	

### 8.8.6.4 Collision function

Item	Parameter	Reference	Status	Support	Value/Comment
1	Collision absence	8.2.1.3	M	Yes <input type="checkbox"/> No <input type="checkbox"/>	IDL signal on the CI circuit, unless sending <i>mau_not_available</i>
2	Collision Presence function requirements	8.2.1.3	8.8.6.1/1 :X !8.8.6.1/1 :M	N/A <input type="checkbox"/> Yes <input type="checkbox"/> No <input type="checkbox"/> N/A <input type="checkbox"/> Yes <input type="checkbox"/> No <input type="checkbox"/>	CS0 on CI circuit at BR +25%, -15% with a duty cycle not worse than 40/60 ratio with $\geq 2$ MAUs transmitting
3	No collision detection with single transmitter	8.2.1.3 8.2.2.2.4	M	Yes <input type="checkbox"/> No <input type="checkbox"/>	No CS0 on CI
4	Collision assertion after transmission of $\geq 20$ bit times	8.2.1.3 8.2.2.2.4	8.8.6.1/1 :X !8.8.6.1/1 :M	N/A <input type="checkbox"/> Yes <input type="checkbox"/> No <input type="checkbox"/> N/A <input type="checkbox"/> Yes <input type="checkbox"/> No <input type="checkbox"/>	CS0 on CI $\leq 17$ BT after collision
5	Collision assertion by transmission $< 20$ bit times	8.2.1.3 8.2.2.2.4	8.8.6.1/1 :X !8.8.6.1/1 :M	N/A <input type="checkbox"/> Yes <input type="checkbox"/> No <input type="checkbox"/> N/A <input type="checkbox"/> Yes <input type="checkbox"/> No <input type="checkbox"/>	CS0 on CI $\leq 29$ BT after collision
6	Collision deassertion after end of collision between second MAU	8.2.1.3	M	Yes <input type="checkbox"/> No <input type="checkbox"/>	IDL on CI $\leq 17$ BT after arrival of end of transmission
7	Collision deassertion after end of collision between more than two MAUs	8.2.1.3	M	Yes <input type="checkbox"/> No <input type="checkbox"/>	IDL on CI $\leq 29$ BT after arrival of end of transmission from all but one MAU

### 8.8.6.5 Monitor function

Item	Parameter	Reference	Status	Support	Value/Comment
1	Signal path	8.2.1.4	8.8.6.1/2 :M	N/A <input type="checkbox"/> Yes <input type="checkbox"/> No <input type="checkbox"/>	From DTE to MAU through CO circuit
2	Transmit disable delay	8.2.1.4	8.8.6.1/2 :M	N/A <input type="checkbox"/> Yes <input type="checkbox"/> No <input type="checkbox"/>	$\leq 20$ ms
3	MAU function in isolated state	8.2.1.4	8.8.6.1/2 :M	N/A <input type="checkbox"/> Yes <input type="checkbox"/> No <input type="checkbox"/>	Receive and collision functions are normal, XMIT disabled



**8.8.6.6 Jabber function**

Item	Parameter	Reference	Status	Support	Value/Comment
1	Jabber function implementation	8.2.1.5	M	Yes [ ] No [ ]	Self-interruption of the transmitter
2	Frame timer range	8.2.1.5	M	Yes [ ] No [ ]	20 ms min, 150 ms max
3	CI circuit during jabber	8.2.1.5 8.2.2.2.4	8.8.6.1/1 :X !8.8.6.1/1 :M	N/A [ ] Yes [ ] No [ ] N/A [ ] Yes [ ] No [ ]	CS0 signal
4	Collision presence function activated after transmit disable	8.2.1.5	M	Yes [ ] No [ ]	No extraneous signal on the coaxial media
5	Unjab timer range	8.2.1.5	O	Yes [ ] No [ ]	0.5 s $\pm$ 50%
6	MAU unjab (reset) with monitor function	8.2.1.5	8.8.6.1/2 :M	N/A [ ] Yes [ ] No [ ]	Isolate message
7	MAU jabber lockup protection	9.4.1	8.8.6.1/1 :M !8.8.6.1/1 :O	N/A [ ] Yes [ ] No [ ] N/A [ ] Yes [ ] No [ ]	Jabber function not activated under worst case conditions in 9.6.5

### 8.8.6.7 MAU to coaxial cable interface

Item	Parameter	Reference	Status	Support	Value/Comment
1	Input impedance	8.3.1.1	M	Yes [ ] No [ ]	$R \geq 100 \text{ k}\Omega$
2	Total capacitive load	8.3.1.1	M	Yes [ ] No [ ]	$C \leq 4 \text{ pF}$
3	Bias current	8.3.1.2	M	Yes [ ] No [ ]	Max +2 $\mu\text{A}$ Min -25 $\mu\text{A}$
4	Transmit offset current	8.3.1.3	M	Yes [ ] No [ ]	-37 mA to -45 mA
5	Transmit ac component	8.3.1.3	M	Yes [ ] No [ ]	+28 mA to offset value
6	Transmitter sink current during collision	8.3.1.3	M	Yes [ ] No [ ]	No more than -25 $\mu\text{A}$ at -7 V; no more than $\pm 250 \mu\text{A}$ at -10 V
7	Rise and fall time at 10 Mb/s	8.3.1.3	M	Yes [ ] No [ ]	25 ns $\pm$ 5 ns (10-90%)
8	Rise and fall time match	8.3.1.3	M	Yes [ ] No [ ]	Within 2 ns at 10 Mb/s
9	Harmonic content at BR	8.3.1.3	M	Yes [ ] No [ ]	2nd and 3rd harmonics $\geq 20 \text{ dB}$ below fundamental, 4th and 5th harmonics $\geq 30 \text{ dB}$ below fundamental, 6th and 7th harmonics $\geq 40 \text{ dB}$ below fundamental, all higher harmonics $\geq 50 \text{ dB}$ below fundamental
10	Transmit signal polarity	8.3.1.4	M	Yes [ ] No [ ]	No inversion of signal from PLS to coaxial cable
11	Transmit signal edge jitter	8.3.1.4	M	Yes [ ] No [ ]	MAU introduce no more than 2 ns of edge jitter
12	Receive collision detection threshold	8.3.1.5	M	Yes [ ] No [ ]	-1.448 V to -1.59 V
13	Receive collision detection threshold, large impulse response	8.3.1.5	M	Yes [ ] No [ ]	-1293 mV * [1+ impulse response] if filter impulse response is larger than nominal
14	No negative edge transmission	8.3.1.4	M	Yes [ ] No [ ]	After cessation of CD output stream on DO or before first edge of next frame on DO

**8.8.6.8 MAU electrical characteristics**

Item	Parameter	Reference	Status	Support	Value/Comment
1	Isolation impedance between MDI and AUI cable (each conductor, including shields)	8.3.2.1	M	Yes [ ] No [ ]	$> 250 \text{ k}\Omega$ at 60 Hz, $< 15 \text{ }\Omega$ for 3 MHz to 30 MHz
2	Breakdown voltage	8.3.2.1	M	Yes [ ] No [ ]	$\geq 1.5 \text{ kV ac, rms}$
3	Current drawn from AUI sources	8.3.2.2	M	Yes [ ] No [ ]	$\leq 0.5 \text{ A}$
4	Operation over VP voltage range	8.3.2.2	M	Yes [ ] No [ ]	11.28–15.75 V, any permissible AUI cable
5	Low VP circuit behavior	8.3.2.2	M	Yes [ ] No [ ]	No disruption of media
6	MAU current labeling	8.3.2.2	M	Yes [ ] No [ ]	Current consumption shall be labeled externally
7	Reliability	8.3.2.3	M	Yes [ ] No [ ]	MTBF $\geq 1$ million hours of continuous operation

**8.8.6.9 MAU-DTE requirements**

Item	Parameter	Reference	Status	Support	Value/Comment
1	AUI electrical characteristics	8.3.3	M	Yes [ ] No [ ]	As specified in Clause 7; refer to 8.8.7.1–5
2	AUI mechanical connection	8.3.4	M	Yes [ ] No [ ]	As specified in Clause 7; refer to 8.8.7.6

### 8.8.6.10 MAU to coaxial cable connection

Item	Parameter	Reference	Status	Support	Value/Comment
1	Standard N-type connector	8.5	O.1	Yes [ ] No [ ]	50 $\Omega$ , according to IEC 60169-16: 1982 and Amd. 1: 1996
*2	Coaxial tap connector	8.5.3	O.1	Yes [ ] No [ ]	
3	Capacitance	8.5.3.1	8.8.6.10/2 :M	N/A [ ] Yes [ ] No [ ]	2 pF nominal at 10 MHz
4	Contact resistance	8.5.3.1	8.8.6.10/2 :M	N/A [ ] Yes [ ] No [ ]	$\leq 50$ m $\Omega$ for shield and center conductor
5	Voltage rating	8.5.3.1	8.8.6.10/2 :M	N/A [ ] Yes [ ] No [ ]	600 V dc or ac rms max
6	Dc leakage resistance between braid and external conductors	8.5.3.1	8.8.6.10/2 :M	N/A [ ] Yes [ ] No [ ]	$> 1$ G $\Omega$
7	Probe current rating	8.5.3.1	8.8.6.10/2 :M	N/A [ ] Yes [ ] No [ ]	0.1 A per contact (probe and shield)
8	Shield current rating	8.5.3.1	8.8.6.10/2 :M	N/A [ ] Yes [ ] No [ ]	1 A surge for 1 s
9	Connector housing	8.5.3.2.1	8.8.6.10/2 :M	N/A [ ] Yes [ ] No [ ]	Shielding $> 40$ dB at 50 MHz
10	Shield probe characteristics	8.5.3.2.3	8.8.6.10/2 :M	N/A [ ] Yes [ ] No [ ]	Effective capture of outer braid

### 8.8.6.11 Safety requirements

Item	Parameter	Reference	Status	Support	Value/Comment
1	MAU labeling	8.6.3	O	Yes [ ] No [ ]	Data rate, current, any applicable safety warnings (recommended)
2	General safety	8.7.1	M	Yes [ ] No [ ]	Conforms to IEC 60950: 1991
3	Susceptibility levels	8.7.3.1	M	Yes [ ] No [ ]	Either ambient plane wave field of 2 V/m from 10 kHz through 30 MHz, 5 V/m from 30 MHz through 1 GHz, or interference voltage of 1 V/ns peak slope, between coaxial cable shield and DTE earth connection
4	Emission levels	8.7.3.2	M	Yes [ ] No [ ]	Comply with applicable local and national standards

## 8.8.7 PICS proforma tables for MAU AUI characteristics

### 8.8.7.1 Signal characteristics

Item	Parameter	Reference	Status	Support	Value/Comment
1	Signaling rate (stated on label)	7.3.2	M	Yes [ ] No [ ]	10 Mb/s
2	CS0 signal frequency (on CI)	7.3.1.2	M	Yes [ ] No [ ]	10 MHz +25%, -15%
3	CS0 signal duty cycle	7.3.1.2	M	Yes [ ] No [ ]	60:40 worst case

### 8.8.7.2 DI and CI driver characteristics

Item	Parameter	Reference	Status	Support	Value/Comment
1	Differential output voltage, loaded	7.4.1.1	M	Yes [ ] No [ ]	Figure 7-11
2	Differential output voltage, idle state	7.4.1.1	M	Yes [ ] No [ ]	≤ 40 mV into test load
3	Differential output voltage, start of idle	7.4.1.1	M	Yes [ ] No [ ]	Figure 7-12
4	Current into test load while idle	7.4.1.1	M	Yes [ ] No [ ]	4 mA max after 80 BT
5	Requirements after idle	7.4.1.2	M	Yes [ ] No [ ]	Second bit to Figure 7-11
6	Common-mode output voltage, ac	7.4.1.3	M	Yes [ ] No [ ]	≤ 40 mV peak, Figure 7-13
7	Differential output voltage, open circuit	7.4.1.4	M	Yes [ ] No [ ]	13 V peak max
8	Common-mode output voltage, dc	7.4.1.5	M	Yes [ ] No [ ]	≤ 5.5 V, Figure 7-13
9	Fault tolerance	7.4.1.6	M	Yes [ ] No [ ]	Figure 7-14
10	Fault current	7.4.1.6	M	Yes [ ] No [ ]	≤ 150 mA, any Figure 7-14 state

### 8.8.7.3 DO receiver characteristics

Item	Parameter	Reference	Status	Support	Value/Comment
1	Unsilenced threshold	7.4.2.1	M	Yes [ ] No [ ]	160 mV max differential
2	High-to-idle transition on DO circuit	7.4.1.1	M	Yes [ ] No [ ]	Must not cause output
3	Differential input impedance at 10 MHz	7.4.2.2	M	Yes [ ] No [ ]	Real part: $77.83 \Omega \pm 6\%$ ; $0 \leq \text{phase angle (deg)}$ $\leq \text{real part} \times 0.0338$
4	Common-mode range, ac	7.4.2.3	M	Yes [ ] No [ ]	3 V min 30 Hz to 40 kHz, 100 mV min 40 kHz to 10 MHz
5	Total common-mode range	7.4.2.4	M	Yes [ ] No [ ]	Magnitude of 0 to 5.5 V ac + dc
6	Common-mode current limit	7.4.2.4	M	Yes [ ] No [ ]	$\leq 1 \text{ mA}$
7	IDL detection	7.3.1.1	M	Yes [ ] No [ ]	$\leq 1.6$ bit times
8	Requirements after idle	7.4.2.5	M	Yes [ ] No [ ]	Receiver in spec after start-up delay
9	Receiver fault tolerance	7.4.2.6	M	Yes [ ] No [ ]	Figure 7–16
10	Input fault current	7.4.2.6	M	Yes [ ] No [ ]	3 mA max

**8.8.7.4 CO receiver characteristics**

Item	Parameter	Reference	Status	Support	Value/Comment
1	Unsquelled threshold	7.4.2.1	8.8.6.1/3 :M	N/A[ ] Yes[ ] No [ ]	160 mV max differential
2	High-to-idle transition on DO circuit	7.4.1.1	8.8.6.1/3 :M	N/A[ ] Yes[ ] No [ ]	Must not cause output
3	Differential input impedance at 10 MHz	7.4.2.2	8.8.6.1/3 :M	N/A[ ] Yes[ ] No [ ]	Real part: $77.83 \Omega \pm 6\%$ ; $0 \leq \text{phase angle (deg)}$ $\leq \text{real part} \times 0.0338$
4	Common-mode range, ac	7.4.2.3	8.8.6.1/3 :M	N/A[ ] Yes[ ] No [ ]	3 V min 30 Hz to 40 kHz, 100 mV min 40 kHz to 10 MHz
5	Total common-mode range	7.4.2.4	8.8.6.1/3 :M	N/A[ ] Yes[ ] No [ ]	Magnitude of 0 to 5.5 V ac + dc
6	Common-mode current limit	7.4.2.4	8.8.6.1/3 :M	N/A[ ] Yes[ ] No [ ]	$\leq 1$ mA
7	IDL detection	7.3.1.1	8.8.6.1/3 :M	N/A[ ] Yes[ ] No [ ]	$\leq 1.6$ bit times
8	Requirements after idle	7.2.4.5	8.8.6.1/3 :M	N/A[ ] Yes[ ] No [ ]	Receiver in spec after start-up delay
9	Receiver fault tolerance	7.4.2.6	8.8.6.1/3 :M	N/A[ ] Yes[ ] No [ ]	Figure 7–16
10	Input fault current	7.4.2.6	8.8.6.1/3 :M	N/A[ ] Yes[ ] No [ ]	3 mA max

**8.8.7.5 Circuit termination**

Item	Parameter	Reference	Status	Support	Value/Comment
1	Common-mode termination	7.4.2.6	M	Yes [ ] No [ ]	If used, must be to VC
2	Pins 1, 4, 8, 11, 14 impedance to VC circuit	7.5.2.8	M	Yes [ ] No [ ]	$\leq 5 \Omega$ at 5 MHz
3	Pins 1, 4, 8, 11, 14 coupling to VC circuit	7.5.2.8	M	Yes [ ] No [ ]	Capacitive

### 8.8.7.6 Mechanical characteristics

Item	Parameter	Reference	Status	Support	Value/Comment
1	D-type connector dimensions	7.6.2	M	Yes [ ] No [ ]	IEC 60807-2: 1992 15-pole male
2	Shell plating material	7.6.2	M	Yes [ ] No [ ]	Conductive
3	Shell multiple contact points	7.6.2	O	Yes [ ] No [ ]	Number not defined (recommended)
4	Shell life expectancy	7.6.2	M	Yes [ ] No [ ]	$\leq 5 \text{ m}\Omega/500$ matings
5	Locking posts and mounting	7.6.1	M	Yes [ ] No [ ]	Figures 7–18, 7–20
	Pin connections:				Circuit
6	3	7.6.3	M	Yes [ ] No [ ]	Data out A
7	10	7.6.3	M	Yes [ ] No [ ]	Data out B
8	11	7.6.3	M	Yes [ ] No [ ]	Capacitor to VC
9	5	7.6.3	M	Yes [ ] No [ ]	Data in A
10	12	7.6.3	M	Yes [ ] No [ ]	Data in B
11	4	7.6.3	M	Yes [ ] No [ ]	Capacitor to VC
12	7	7.6.3	M	Yes [ ] No [ ]	Control out A
13	15	7.6.3	M	Yes [ ] No [ ]	Control out B
14	8	7.6.3	M	Yes [ ] No [ ]	Capacitor to VC
15	2	7.6.3	M	Yes [ ] No [ ]	Control in A
16	9	7.6.3	M	Yes [ ] No [ ]	Control in B
17	1	7.6.3	M	Yes [ ] No [ ]	Capacitor to VC
18	6	7.6.3	M	Yes [ ] No [ ]	Voltage common
19	13	7.6.3	M	Yes [ ] No [ ]	Voltage plus
20	14	7.6.3	M	Yes [ ] No [ ]	Capacitor to VC
21	Shell	7.6.3	M	Yes [ ] No [ ]	Protective ground (conductive shell)



## 8.8.8 PICS proforma tables for 10BASE5 coaxial cable

### 8.8.8.1 10BASE5 coaxial cable characteristics

Item	Parameter	Reference	Status	Support	Value/Comment
1	Characteristic impedance	8.4.1.1	M	Yes [ ] No [ ]	$50 \Omega \pm 2 \Omega$ , measured according to IEC 60096-1: 1986 and Amd. 2: 1993
2	Impedance variation per 2 m segment	8.4.1.1	O	Yes [ ] No [ ]	$\pm 3 \Omega$
3	Attenuation of 500 m segment	8.4.1.2	M	Yes [ ] No [ ]	$\leq 8.5$ dB with 10 MHz sine wave, $\leq 6.0$ dB with 5 MHz sine wave
4	Velocity of propagation	8.4.1.3	M	Yes [ ] No [ ]	Min 0.77 c
5	Edge jitter of 500 m cable	8.4.1.4	M	Yes [ ] No [ ]	$\leq 7$ ns
6	Transfer impedance	8.4.1.5	M	Yes [ ] No [ ]	According to Figure 8–7
7	Cable DC loop resistance (center conductor plus shield)	8.4.1.6	M	Yes [ ] No [ ]	$\leq 10$ m $\Omega$ /m at 20 °C
Coaxial cable properties:					
8	a) Center conductor, dielectric, shield system, insulating jacket	8.4.2.1.1	M	Yes [ ] No [ ]	
9	b) Concentricity	8.4.2.1.1	M	Yes [ ] No [ ]	$\geq 92\%$
10	c) Jacket, shield, dielectric	8.4.2.1.1	M	Yes [ ] No [ ]	ierceable
11	d) Cable flexibility	8.4.2.1.1	M	Yes [ ] No [ ]	support bend radius of 254 mm
12	Center conductor	8.4.2.1.2	M	Yes [ ] No [ ]	$2.17 \text{ mm} \pm 0.013 \text{ mm}$
13	Dielectric material	8.4.2.1.3	M	Yes [ ] No [ ]	meets 8.4.1.2, 8.4.1.3 and 8.4.2.1.1 c)
Shielding system:					
14	a) Inside diameter	8.4.2.1.4	M	Yes [ ] No [ ]	$\geq 6.15 \text{ mm}$
15	b) Outside diameter	8.4.2.1.4	M	Yes [ ] No [ ]	$8.28 \text{ mm} \pm 0.178 \text{ mm}$
16	c) Outermost shield	8.4.2.1.4	M	Yes [ ] No [ ]	$> 90\%$ coverage
17	Jacket material	8.4.2.1.5	M	Yes [ ] No [ ]	meets 8.4.1 and 8.4.2 specs

Item	Parameter	Reference	Status	Support	Value/Comment
18	Jacket dimensions, Polyvinyl Chloride	8.4.2.1.5	O.2	Yes [ ] No [ ]	OD of 10.287 mm ± 0.178 mm
19	Jacket dimensions, Fluoropolymer	8.4.2.1.5	O.2	Yes [ ] No [ ]	OD of 9.525 mm ± 0.254 mm
20	Flammability and smoke criteria	8.4.2.1.5	M	Yes [ ] No [ ]	Meet applicable local and national codes
21	Jacket marking	8.4.2.2	M	Yes [ ] No [ ]	Annular rings spaced 2.5 m ± 5 cm
22	Color of jacket	8.4.2.2	O	Yes [ ] No [ ]	Bright (example: yellow)
Total segment dc loop resistance:					
23	a) Sum of center conductor, connector and shield	8.4.3	M	Yes [ ] No [ ]	≤5 Ω at 20° C
24	b) Inline connector pair or MAU	8.4.3	M	Yes [ ] No [ ]	≤10 mΩ at 20° C
25	Inline coaxial extension connector	8.5.1	M	Yes [ ] No [ ]	Type N plug connector
26	Coaxial cable termination	8.5.2.1	M	Yes [ ] No [ ]	50 Ω ± 1% at 0–20 MHz, phase angle ≤ 5°, power rating ≥1 Ω

## 9. Repeater unit for 10 Mb/s baseband networks

### 9.1 Overview

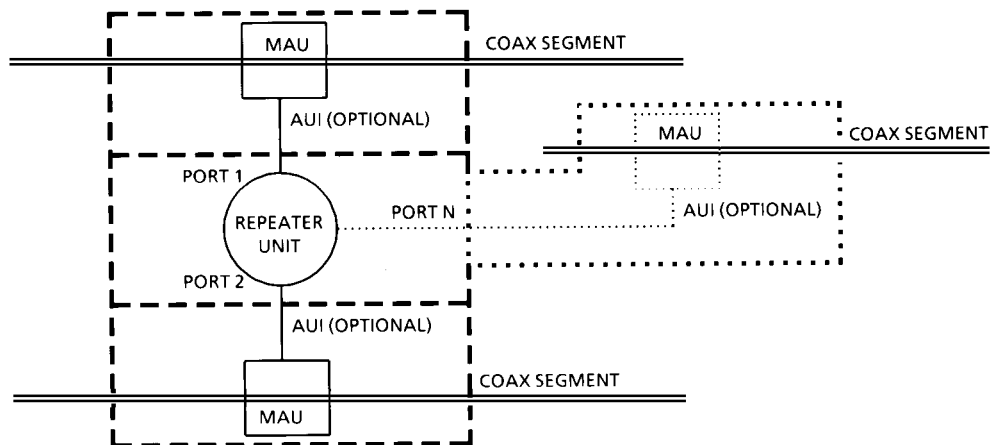
This clause specifies a repeater for use with IEEE 802.3 10 Mb/s baseband networks. A repeater for any other IEEE 802.3 network type is beyond the scope of this clause.

A repeater set connects segments of network medium together, thus allowing larger topologies and a larger MAU base than are allowed by rules governing individual segments.

Repeater sets are used to extend the network length and topology beyond what could be achieved by a single mixing segment. Mixing segments may be connected directly by a repeater set (Figure 9–1) or by several repeater units that are, in turn, connected by link segments. Repeater sets are also used as the hub in a star topology network in which DTEs attach directly to link segments (e.g., 10BASE-T, Clause 14). Allowable topologies shall contain only one operative signal path between any two points on the network. The proper operation of a CSMA/CD network requires network size to be limited to control round-trip propagation delay to meet the requirements of 4.2.3.2.3 and 4.4.2, and the number of repeaters between any two DTEs to be limited in order to limit the shrinkage of interpacket gap as it travels through the network. The method for validating networks with respect to these requirements is specified in Clause 13.

If the repeater set uses MAUs connected via AUIs to a repeater unit, these MAUs shall not perform the *signal\_quality\_error* Test function. A manufacturer may, optionally, integrate one or all MAUs into a single package with the repeater unit (internal MAUs). In all cases, the MAU portion of the repeater set must be counted toward the maximum number of MAUs on each segment. A repeater set is not a station and does not count toward the overall limit of 1024 stations on a network.

A repeater set can receive and decode data from any segment under worst-case noise, timing, and signal amplitude conditions. It retransmits the data to all other segments attached to it with timing and amplitude restored. The retransmission of data occurs simultaneously with reception. If a collision occurs, the repeater set propagates the collision event throughout the network by transmitting a Jam signal.



NOTE: The AUI is not necessarily exposed when the MAU is, optionally, part of the physical repeater.

Figure 9–1—Repeater set, coax-to-coax configuration

## 9.2 References

See 1.3.

## 9.3 Definitions

See 1.4.

## 9.4 Compatibility interface

The repeater shall attach to its network segments by any of the means specified below.

### 9.4.1 AUI compatibility

The repeater unit shall be compatible at its AUI connector (if so equipped) as specified in Clause 7 with the exception of the *signal\_quality\_error* message Test, 7.2.1.2.3, which shall not be implemented.

10BASE5 and 10BASE2 MAUs associated with the repeater unit shall be as specified in Clause 8 for type 10BASE5 and Clause 10 for type 10BASE2 with the following restrictions:

- a) The MAU shall implement receive mode collision detect as defined in 8.3.1.5 or 10.4.1.5.
- b) The MAU shall not implement the *signal\_quality\_error* Message Test function as defined in 8.2.1.1 and 10.3.1.1. The MAU shall not activate its Jabber function when operated under the worst-case Jabber Lockup Protection condition as specified in 9.6.5.
- c) The MAU shall operate only in the normal mode as defined in 8.1.3.4, not in the monitor mode.

All other MAUs associated with the repeater unit shall be as specified in their respective clauses and shall not perform the *signal\_quality\_error* Message Test function.

### 9.4.2 Mixing segment compatibility

The repeater set, which includes MAUs integrated with the repeater package (internal MAUs), may have any of the interfaces specified in the following subclauses. The MAUs associated with the repeater that are connected in this manner shall be subject to the restrictions of MAUs as specified in 9.4.1.

#### 9.4.2.1 Direct coaxial cable attachment compatibility

The repeater shall be compatible at its coaxial tap connector (if so equipped) as specified in 8.5.3 of the 10BASE5 standard.

#### 9.4.2.2 “N” connector compatibility

The repeater shall be compatible at its Type N connector (if so equipped) as specified in 8.5.

#### 9.4.2.3 BNC compatibility

The repeater shall be compatible at its BNC connector (if so equipped) as specified in 10.6.

#### 9.4.2.4 BFOC/2.5 (10BASE-FP) compatibility

The repeater shall be compatible at its BFOC/2.5 10BASE-FP connector (if so equipped) as specified in 15.3.2 (also see 15.1).

### **9.4.3 Link segment compatibility**

The compatibility interfaces for link segments including IRL segments are either vendor-dependent, as specified in 9.4.3.1, or are vendor-independent MDI, as defined in the remainder of this clause. The MAUs associated with the repeater that are connected in this manner shall be subject to the restrictions of MAUs as specified in 9.4.1.

#### **9.4.3.1 Vendor-dependent IRL**

The budget allowances for the topology supported by the IRL shall ensure that the total network round-trip delay requirement is met and the maximum collision frame size of 511 bits is not exceeded. (See 13.4.1.)

#### **9.4.3.2 Fiber optic FOIRL compatibility**

The repeater shall be compatible at its FSMA connector (if so equipped) as specified in 9.9.

#### **9.4.3.3 Twisted-pair jack compatibility**

The repeater set shall be compatible at its 8-pin modular jack (if so equipped), as specified in 14.5.

#### **9.4.3.4 Fiber optic 10BASE-FB and 10BASE-FL compatibility**

The repeater shall be compatible at its BFOC/2.5 (10BASE-FB and/or 10BASE-FL) connector (if so equipped) as specified in 15.3.2 (also see 15.1).

## **9.5 Basic functions**

### **9.5.1 Repeater set network properties**

The repeater set shall be transparent to all network acquisition activity and to all DTEs. The repeater set shall not alter the basic fairness criterion for all DTEs to access the network or weigh it toward any DTE or group of DTEs regardless of network location. A repeater set shall not attempt to be a packet store and forward device.

Repeaters are not addressable. An addressable station on the network that controls a repeater is outside the scope of this standard.

### **9.5.2 Signal amplification**

The repeater set (including its associated or integral MAUs) shall ensure that the amplitude characteristics of the signals at the MDI outputs of the repeater set are within the tolerance of the specification for the appropriate MAU type. Therefore, any loss of signal-to-noise ratio due to cable loss and noise pickup is regained at the output of the repeater set as long as the incoming data is within the system specification.

### **9.5.3 Signal symmetry**

The repeater set shall ensure that the symmetry characteristics of the signals at the MDI outputs of a repeater set are within the tolerance of the specification for the appropriate MAU type. Therefore, any loss of symmetry due to MAUs and media distortion is regained at the output of the repeater set.

### 9.5.4 Signal retiming

The repeater unit shall ensure that the encoded data output from the repeater unit is within the jitter tolerance of a transmitting DTE as specified in 7.3. Therefore jitter cannot accumulate over multiple segments.

### 9.5.5 Data handling

The repeater unit, when presented a packet at any of its ports, shall pass the data frame of said packet intact and without modification, subtraction, or addition to all other ports connected with the repeater unit. The only exceptions to this rule are when contention exists among any of the ports or when the receive port is partitioned as defined in 9.6.6. Between unpartitioned ports, the rules for collision handling (9.5.6) take precedence.

#### 9.5.5.1 Start-of-packet propagation delays

The start-of-packet propagation delay for a repeater set is the time delay between the first edge transition of the packet on its repeated from (input) port to the first edge transition of the packet on its repeated to (output) port (or ports).

For a repeater unit with AUI connectors at input and output ports, this time shall be less than or equal to 8 bit times.

For a repeater set with internal MAUs on input and output ports, additional delays shall be allowed as enumerated in Table 9–1.

**Table 9–1—Start-of-packet propagation delays  
(Repeater unit delay of 8 BT plus)**

MAU type	Input (BT)	Output (BT)
10BASE5	6.5	3.5
10BASE2	6.5	3.5
FOIRL	3.5	3.5
10BASE-T	8	5
10BASE-FP	3	4
10BASE-FB	2	2
10BASE-FL	5	5

#### 9.5.5.2 Start-of-packet variability

The start-of-packet variability, defined as the total worst-case difference between start-of-packet propagation delays for successive packets separated by 96 bit times or less, shall be less than 4 bit times for a repeater unit. For a 10BASE-FB repeater set the total worst-case difference between start-of-packet propagation delays for successive packets separated by 96 bit times or less, shall be less than 2 bit times for a repeater set, all of which is allocated to the repeater unit.

## 9.5.6 Collision handling

### 9.5.6.1 Collision presence

All MAUs connected to the repeater unit shall provide uninterrupted Carrier Sense. Uninterrupted Carrier Sense means that the input messages remain valid during activity on the medium even in the presence of a collision. 10BASE5 and 10BASE2 MAUs shall provide this capability by implementing Receive Mode Collision Detection.

### 9.5.6.2 Jam generation

If a collision is detected on any of the ports to which the repeater set is transmitting, the repeater set shall transmit a Jam to all of the ports to which it is connected. The Jam shall be transmitted in accordance with the Repeater Unit State Diagram in Figure 9–2 and shall be as specified in 4.2.3.2.4 with the further constraint that the first 62 bits transmitted to any port shall be a pattern of alternate 1's and 0's starting with the first bit transmitted as a 1.

### 9.5.6.3 Collision-jam propagation delays

The start-of-collision propagation delay for a repeater set is the time delay between the first edge transition of the *signal\_quality\_error* signal on any of its ports to the first edge transition of the Jam on its (output) port (or ports).

For a repeater unit with AUI connectors at input and output ports, this time shall be less than or equal to 6.5 bit times.

For a repeater set with internal MAUs on input and output ports, additional delays shall be allowed as enumerated in Table 9–2.

**Table 9–2—Start-of-collision jam delays  
(repeater unit delay of 6.5 BT plus)**

MAU type	Input (BT)	Output (BT)
10BASE5	9 <sup>a</sup>	3.5
10BASE2	9 <sup>a</sup>	3.5
FOIRL	3.5	3.5
10BASE-T	9	5
10BASE-FP	11.5	1
10BASE-FB	3.5	2
10BASE-FL	3.5	5
<sup>a</sup> This does not include collision rise time on the coaxial media. For the worst-case round-trip delay calculation, collision rise time plus MAU propagation delay = 17 bit times.		

The cessation-of-jam propagation delay for a repeater unit is the time delay between the input signals at its ports reaching a state such that Jam should end at a port and the last transition of Jam at that port. The states of the input signals that should cause Jam to end are covered in detail in the repeater state diagrams.

For a repeater unit with AUI connectors at input and output ports, this time shall be less than or equal to 5 bit times when not extending fragments. When extending fragments, this delay may be longer as required by the fragment extension algorithm. See 9.6.4.

For a repeater set with internal MAUs on input and output ports, an additional allowance for cessation-of-Jam propagation shall be allowed as specified in Table 9–3.

For a repeater set with internal MAUs on its input ports, an additional delay allowance for DI and for *signal\_quality\_error* de-assertion shall be made as specified in Table 9–3.

**Table 9–3—Cessation-of-jam delays  
(repeater unit delay of 5 BT plus)**

MAU type	Cessation-of-Collision jam from DI (BT)		Cessation-of-Collision jam from SQE (BT)	
	Input	Output	Input	Output
10BASE5	0.5	0.5	20	0.5
10BASE2	0.5	0.5	20	0.5
FOIRL	0.5	0.5	7	0.5
10BASE-T	2	2	9	2
10BASE-FP	3	3	36	3
10BASE-FB	5	2	5	2
10BASE-FL	2	2	7	2

#### 9.5.6.4 Transmit recovery time

It is essential that the repeater unit not monitor a port for input for a short time after the repeater stops transmitting to that port. This recovery time prevents the repeater from receiving its own transmission as a new receive activity. The minimum recovery time allowable for a repeater is implementation-dependent, but must be greater than the sum of the delays in the transmit and receive paths for the port. In all cases the recovery time must be less than 10 bit times from the last transition on the transmitting AU interface.

#### 9.5.6.5 Carrier recovery time

During a collision, the *input\_idle* signal is unreliable for short periods of time (bits) because of the possibility of signal cancellation on the collision segment. In order to prevent premature detection of the true end of the collision, the repeater unit must wait for data to become sensed from a port for a short time after *signal\_quality\_error* has gone inactive from that port. This recovery time prevents the repeater from prematurely ending a Jam on an active network. The minimum carrier recovery time allowable for a repeater is implementation-dependent, but shall be greater than the CARRIER ON time after *signal\_quality\_error* is de-asserted. In all cases, the carrier recovery time shall be less than 4 bit times from the last transition on the AU Interface.

#### 9.5.7 Electrical isolation

Network segments that have different isolation and grounding requirements shall have those requirements provided by the port-to-port isolation of the repeater set.



## 9.6 Detailed repeater functions and state diagrams

A precise algorithmic definition is given in this subclause, providing a complete procedural model for the operation of a repeater, in the form of state diagrams. Note that whenever there is any apparent ambiguity concerning the definition of repeater operation, the state diagrams should be consulted for the definitive statement.

The model presented in this subclause is intended as a primary specification of the functions to be provided by any repeater unit. It is important to distinguish, however, between the model and a real implementation. The model is optimized for simplicity and clarity of presentation, while any realistic implementation should place heavier emphasis on such constraints as efficiency and suitability to a particular implementation technology.

It is the functional behavior of any repeater unit implementation that shall match the standard, not the internal structure. The internal details of the procedural model are useful only to the extent that they help specify the external behavior clearly and precisely. For example, the model uses a separate Transmit Timer state diagram for each port. However, in an actual implementation, the hardware may be shared.

### 9.6.1 State diagram notation

The notation used in the state diagrams (Figure 9–2 through Figure 9–5) follows the conventions in 1.2.1.

#### *Description of state diagram variables*

##### *Input/Output variables*

###### DataIn (X)

Status of DataIn input at port X.

Values: **II** ; *input\_idle*; i.e., indicates no activity

**-II** ; indicates activity

Note that DataIn (X) may be undefined during collision but that it is a don't care in all instances when this is true.

###### CollIn (X)

Status of ControlIn input at port X.

Values: **SQE** ; *signal\_quality\_error*; i.e., indicates collision

**-SQE** ; indicates no collision

###### Out (X)

Type of output repeater is sourcing at port X.

Values: **Idle** ; Repeater is not transmitting

**-Idle** ; Repeater is transmitting Preamble Pattern or Data or Jam or TwoOnes.

**Preamble Pattern** ; Repeater is sourcing alternating 1's and 0's on port X.

**Data** ; Repeater is repeating data frame on port X.

**Jam** ; Repeater is sourcing Jam on port X.

**TwoOnes** ; Repeater is sourcing two consecutive Manchester-encoded ones on port X.

###### DisableOut (X)

Override of Out (X)

Values: **ON** ; Disable repeater transmission regardless of value of Out (X).

**-ON** ; Repeater transmission depends on the value of Out (X).

### **Port variables**

#### TT (X)

Transmit Timer indicates number of bits transmitted on port X.  
Values: Positive integers

### **Inter-Process flags**

#### AllDataSent

All received data frame bits have been sent.

#### Bit Transmitted

Indicates a bit has been transmitted by the repeater unit.

#### DataRdy

Indicates the repeater has detected the SFD and is ready to send the received data. The search for SFD shall not begin before 15 bits have been received. Note, transmit and receive clock differences shall also be accommodated.

#### Tw1

Wait Timer for the end of transmit recovery time (see 9.5.6.4). It is started by StartTw1. Tw1Done is satisfied when the end of transmit recovery time is completed.

#### Tw2

Wait Timer for the end of carrier recovery time (see 9.5.6.5). It is started by StartTw2. Tw2Done is satisfied when the timer has expired.

#### Tw3

Wait Timer for length of continuous output (see 9.6.5). It is started by StartTw3. Tw3Done is satisfied when the timer has expired.

#### Tw4

Wait Timer for time to disable output for Jabber Lockup Protection (see 9.6.5). It is started by StartTw4. Tw4Done is satisfied when the timer has expired.

### **Port functions**

#### Port (*Test*)

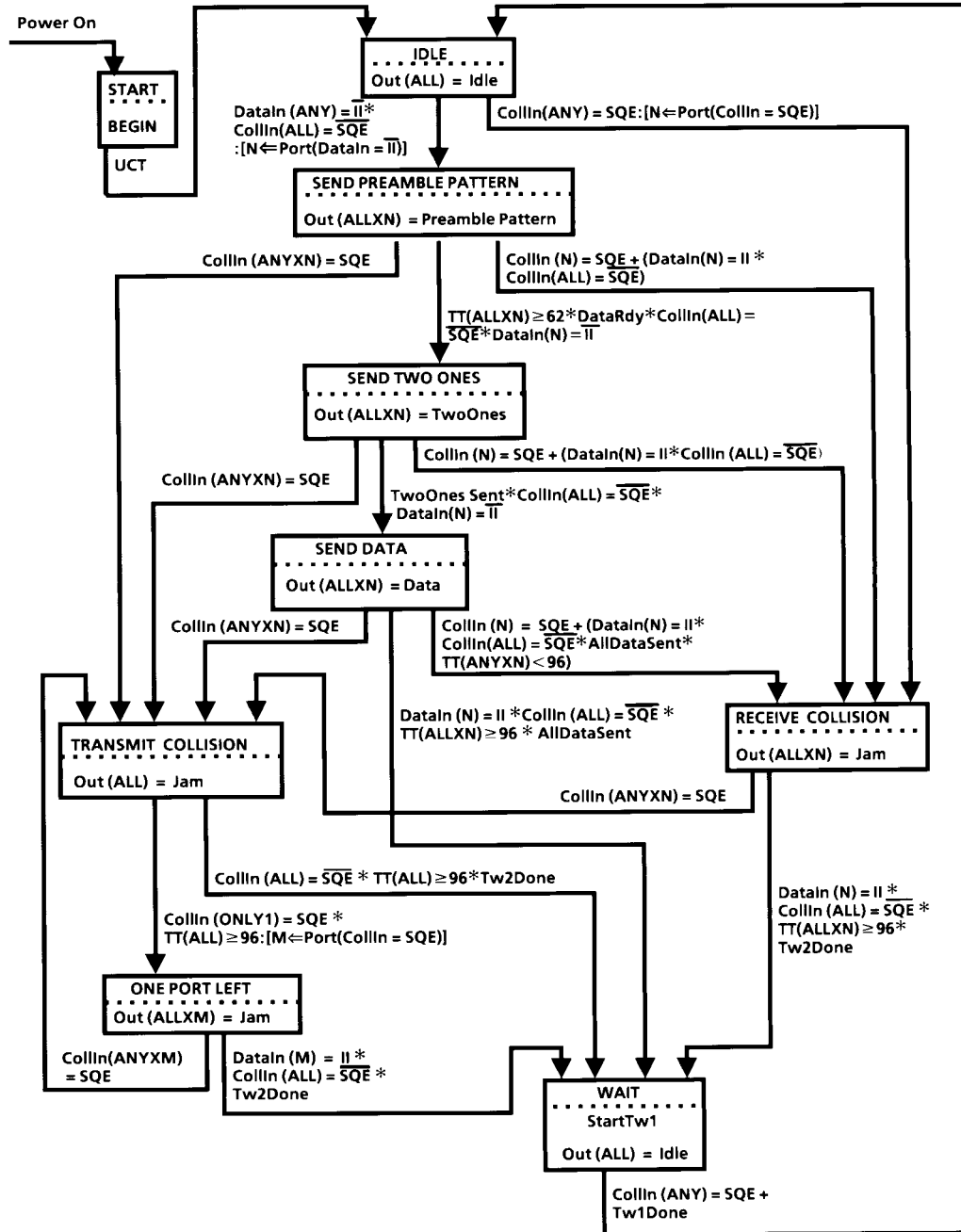
A function that returns the designation of a port passing the test condition. For example, Port (CollIn=SQE) returns the designation: X for a port that has SQE true. If multiple ports meet the test condition, the Port function will be assigned one and only one of the acceptable values.

### **Port designation**

Ports are referred to by number. Port information is obtained by replacing the X in the desired function with the number of the port of interest. Ports are referred to in general as follows:

ALL	Indicates all repeater ports are to be considered. All ports shall meet test conditions in order for the test to pass.
ANY	Indicates all ports are to be considered. One or more ports shall meet the test conditions in order for the test to pass.
ONLY1	Indicates all ports are to be considered. One, but not more than one, port shall meet the test condition in order for the test to pass.
X	Generic port designator. When X is used in a state diagram, its value is local to that diagram and not global to the set of state diagrams.
N	Is defined by the Port function on exiting the IDLE state of Figure 9–2. It indicates a port that caused the exit from the IDLE state.
M	Is defined by the Port function on exiting the TRANSMIT COLLISION state of Figure 9–2. It indicates the only port where CollIn=SQE.

- ALLXN Indicates all ports except N should be considered. All ports considered shall meet the test conditions in order for the test to pass.
- ALLXM Indicates all ports except M should be considered. All ports considered shall meet the test conditions in order for the test to pass.
- ANYXN Indicates any port other than N meeting the test conditions shall cause the test to pass.
- ANYXM Indicates any port other than M meeting the test conditions shall cause the test to pass.



NOTE: Out (X) = Idle in all instances unless specified otherwise.

Figure 9–2—Repeater unit state diagram

### 9.6.2 Data and collision handling

The repeater unit shall implement the CARRIER\_ON function for all its ports. Upon detection of carrier from one port, the repeater unit shall repeat all received signals in the Data Frame from that port to the other port (or ports).

The repeater unit data and collision-handling algorithm shall be as defined in Figure 9–2.

### 9.6.3 Preamble regeneration

The repeater unit shall output at least 56 bits of preamble followed by the SFD. When the repeater unit must send more than 56 bits, the maximum length preamble pattern it shall send is the number received plus 6. If the receive port is type 10BASE-FB, then the maximum length preamble pattern it shall send is the number received plus 2.

NOTE—Type 10BASE-FB ports always receive at least 56 bits of preamble due to the constraints on the transmitter and link.

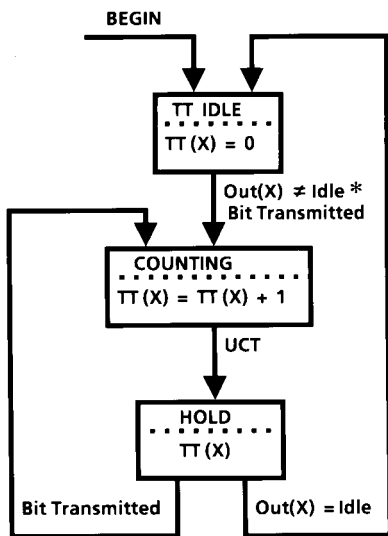


Figure 9–3—Transmit timer state diagram for Port X

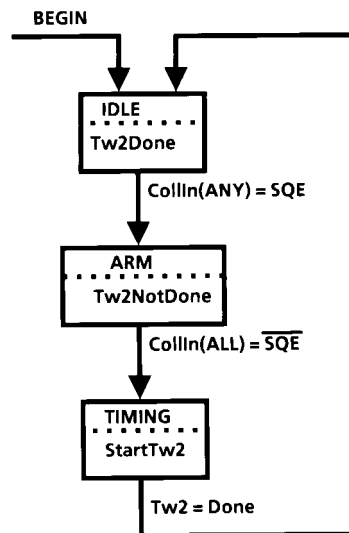


Figure 9–4—Tw2 state diagram

### 9.6.4 Fragment extension

If the received bit sequence from CARRIER\_ON to CARRIER\_OFF is fewer than 96 bits in length, including preamble, the repeater unit shall extend the output bit sequence with Jam such that the total number of bits output from the repeater unit shall equal 96.

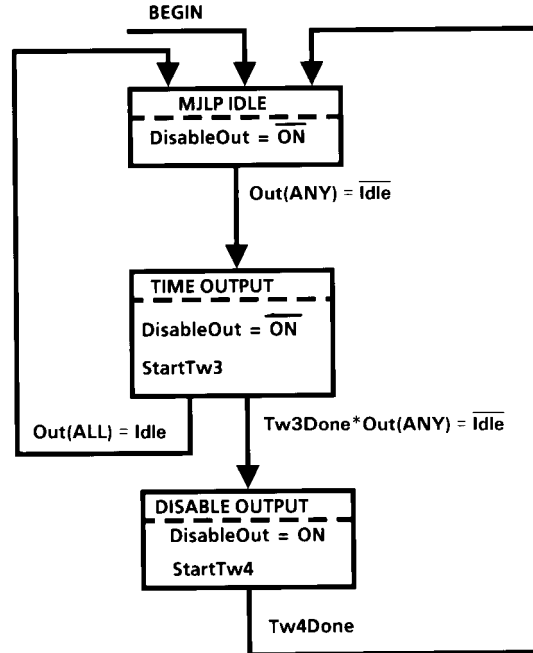


Figure 9-5—MAU jabber lockup protection state diagram

### 9.6.5 MAU Jabber Lockup Protection

MAU Jabber Lockup Protection must operate as shown in the MAU Jabber Lockup Protection state diagram. The repeater unit shall interrupt its output if it has transmitted continuously for longer than 5 ms or 50 000 bit times  $- 20\% + 50\%$ . The repeater unit shall then, after 96 to 116 bit times (9.6 to 11.6  $\mu$ s), re-enable transmissions.

### 9.6.6 Auto-Partitioning/Reconnection (optional)

#### 9.6.6.1 Overview

In large multisegment networks it may be desirable that the repeater unit protect the network from some fault conditions that would halt all network communication. A potentially likely cause of this condition could be due to a cable break, a faulty connector, or a faulty or missing termination.

In order to isolate a faulty segment's collision activity from propagating through the network, the repeater unit may optionally implement an auto-partition algorithm and, on detection of the malfunction being cleared, an auto-reconnection algorithm.

#### 9.6.6.2 Detailed auto-partition/reconnection algorithm state diagram

Repeater sets with 10BASE-T MAUs shall implement an auto-partition/reconnection algorithm on those parts. The repeater unit may optionally implement an auto-partition/reconnection algorithm that protects the rest of the network from an open-circuited segment. If the repeater unit provides this function, it shall conform to the state diagram of Figure 9-6.

The algorithm defined in Figure 9-6 shall isolate a segment from the network when one of the following two conditions has occurred on the segment:

- a) When a consecutive collision count has been reached; or
- b) When a single collision duration has exceeded a specific amount of time.

When a segment is partitioned, DataIn (X) and CollIn (X) from that segment are forced to II (input idle) and –SQE (no collision), respectively, so that activity on the port will not affect the repeater unit. Output from the repeater to the segment is not blocked.

The segment will be reinstated when the repeater has detected activity on the segment for more than the number of bits specified for Tw5 without incurring a collision.

### **Description of state diagram variables and constants**

#### **Port constants**

##### **CCLimit**

The number of consecutive collisions that must occur before a segment is partitioned. The value shall be greater than 30.

#### **Input/Output variables**

##### **DIPresent(X)**

Data in from the MAU on port X. (This input is gated by the partition state diagram to produce DataIn (X) to the main state diagram.)

Values: II = *input\_idle* ; no activity  
–II = Input not idle ; activity

##### **CIPresent(X)**

Control input from the MAU on port X. (This input is gated by the partition state diagram to produce CollIn (X) to the main state diagram.)

Values: SQE = *signal\_quality\_error* ; indicates collision  
–SQE ; indicates no collision

#### **Port variables**

##### **CC(X)**

Consecutive port collision count on a particular port X. Partitioning occurs on a terminal count of CCLimit being reached.

Values: Positive integers up to a terminal count of CCLimit.

#### **Inter-Process Flags**

##### **Tw5**

Wait Timer for length of packet without collision. Its value shall be between 450 and 560 bit times. It is started by StartTw5. Tw5Done is satisfied when the timer has expired.

##### **Tw6**

Wait Timer for excessive length of collision. Its value shall be between 1000 and 30 000 bit times. It is started by StartTw6. Tw6Done is satisfied when the timer has expired.

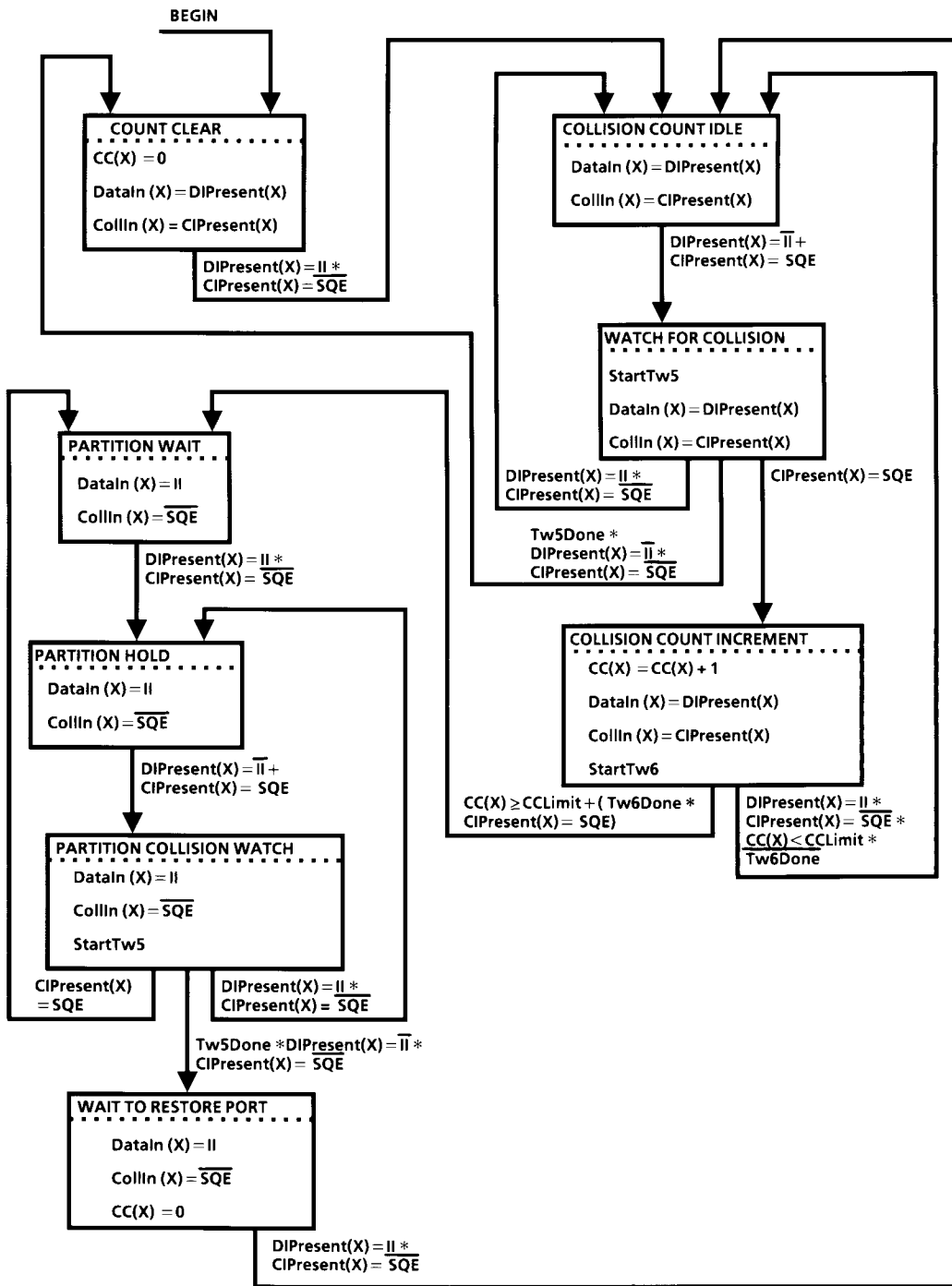


Figure 9-6—Partitioning state diagram for Port X

## 9.7 Electrical isolation

There are two electrical power distribution environments to be considered that require different electrical isolation properties.

Environment A—When a LAN or LAN segment, with all its associated interconnected equipment, is entirely contained within a single low-voltage power distribution system and within a single building.

Environment B—When a LAN crosses the boundary between separate power distribution systems or the boundaries of a single building.

The repeater unit shall comply with applicable local and national codes related to safety. See [B26].

### 9.7.1 Environment A requirements

Attachment of network segments via repeaters (sets) possessing internal MAUs requires electrical isolation of 500 V rms, 1 min withstand, between the segment and the protective ground of the repeater unit.

For repeater ports that connect to external MAUs via an AU Interface, the requirement for isolation is encompassed within the isolation requirements of the basic MAU/medium standard. (See 8.3.2.1, 9.9.3.1, 10.4.2.1, 14.3.1.1, and 15.3.4.) The repeater unit shall not require any electrical isolation between exposed AU Interfaces or between exposed AU Interfaces and chassis ground of the repeater unit. No isolation boundary need therefore exist at any AUI compatible interface (that is, “D” connector) provided by a repeater unit.

### 9.7.2 Environment B requirements

The attachment of network segments, which cross environment A boundaries, requires electrical isolation of 1500 V rms, 1 min withstand, between each segment and all other attached segments and also the protective ground of the repeater unit.

If segments are of an electrically conductive medium, it is recommended that this isolation be provided by the use of external MAUs connected by AU Interfaces. If internal MAUs are used for attachment to conductive media segments, then the segments shall be installed such that it is not possible for an equipment user to touch the trunk cable screen or signal conductor. A repeater of this variety requires professional installation.

The requirements for interconnected electrically conducting LAN segments that are partially or fully external to a single building environment may require additional protection against lightning strike hazards. Such requirements are beyond the scope of this standard.

It is recommended that the above situation be handled by the use of a nonelectrically conducting LAN segment (see 9.9 or Clause 15).

## 9.8 Reliability

A 2-port repeater set shall be designed to provide a mean time between failure (MTBF) of at least 50 000 hours of continuous operation without causing a communication failure among stations attached to the network medium. Repeater sets with more than two ports shall add no more than  $3.46 \times 10^{-6}$  failures per hour for each additional port.

The repeater set electronics shall be designed to minimize the probability of component failures within the repeater electronics that prevent communication among the other MAUs on the individual coaxial cable



segments. Connectors and other passive components comprising the means of connecting the repeater to the coaxial cable shall be designed to minimize the probability of total network failure.

## **9.9 Medium attachment unit and baseband medium specification for a vendor-independent FOIRL**

### **9.9.1 Scope**

#### **9.9.1.1 Overview**

A vendor-independent FOIRL provides a standard means for connecting a repeater via optical fiber to another repeater or to a DTE. It thus extends the network length and topology beyond that which could be achieved by interconnecting coaxial cable segments via repeater sets only, as defined in 8.6 or 10.7. A vendor-independent FOIRL is suited for interconnecting repeaters and their respective segments located in different buildings. FOMAUs that are used for the DTE end of the link segment are beyond the scope of this clause. See Clause 18.

NOTE—The FOMAU specified in 9.9 has been superseded by the specification to be found in Clause 18. The new specification is fully compatible (except for media connector) with the specifications of 9.9 at the MDI. The new specification calls out more recent practice in connectors and state machines. It also provides improved performance for long link segments and reflects more recent industry input on flux parameters.

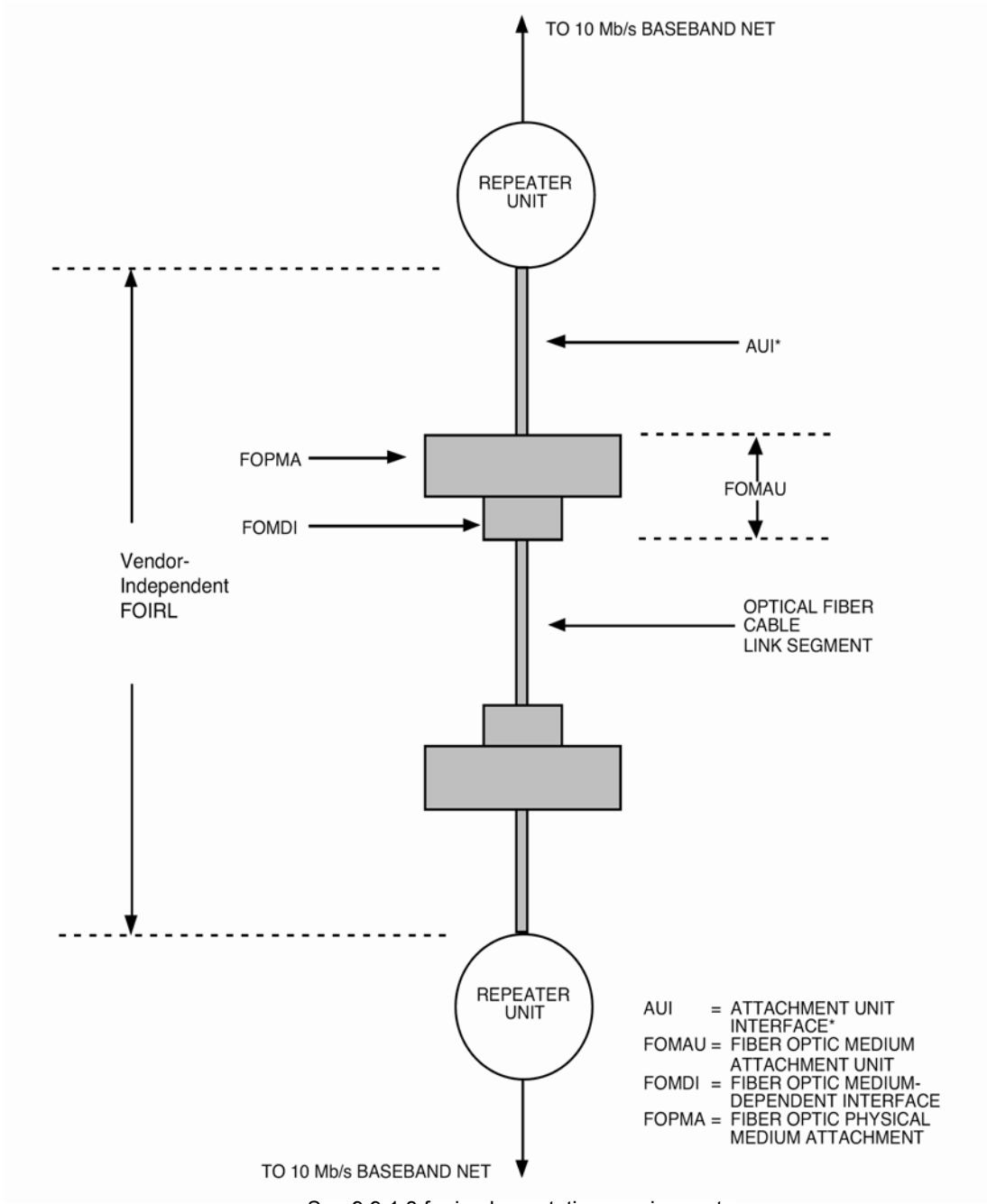
In particular, this clause defines the following:

- a) The functional, optical, electrical, and mechanical characteristics of a fiber optic MAU (FOMAU) suitable for interfacing to a repeater unit, either directly (FOMAU and repeater unit integrated into a single package) or via an AUI mechanical connection.
- b) Various optical fiber sizes suitable for connecting only two FOMAUs.

A schematic of the vendor-independent FOIRL and its relationship to the repeater unit is shown in Figure 9–7. The vendor-independent FOIRL comprises an optical fiber cable link segment, a vendor-independent FOMAU at each end of the link segment and, if present, AUI cables.

The purpose of this specification is to enable interoperability of FOMAUs that originate from different manufacturers, thereby facilitating the development of simple and inexpensive inter-repeater links (IRLs). To satisfy this objective, the FOMAU has the following general characteristics:

- Enables coupling the repeater unit PLS directly, or by way of the AUI mechanical connection, to the explicit baseband optical fiber cable link segment defined in this clause of the standard.
- Supports signaling at a data rate of 10 Mb/s.
- Provides for driving up to 1000 m of an optical fiber cable link segment.
- Operates indistinguishably from other types of repeater set MAUs, as defined in their respective 10 Mb/s baseband MAU sections when viewed from the AU Interface.
- Supports 10 Mb/s baseband system configurations as defined in Clause 13 of this standard.
- Allows integration of the FOMAU into a single package with the repeater unit, thereby eliminating the need for an AUI mechanical connection.



**Figure 9-7—Schematic of the vendor-independent FOIRL and its relationship to the repeater unit**

### 9.9.1.2 Application perspective: FOMAU and medium objectives

This clause states the broad objectives underlying the vendor-independent FOIRL specification defined throughout this clause of the standard. These are as follows:

- a) Provide the physical means for connecting a repeater via fiber to another repeater or to a DTE.
- b) Define a physical interface for the vendor-independent FOMAU component of the vendor-independent FOIRL that can be implemented independently among different manufacturers of hardware and achieve the intended level of compatibility when interconnected in a common IRL.
- c) Provide a communication channel capable of high bandwidth and low bit error ratio performance. The resultant BER of the FOIRL should be less than one part in  $10^{10}$ .
- d) Provide a means to prevent packet transmission through an FOIRL when transmission capability in one or both directions is disrupted.

### 9.9.1.3 Compatibility considerations

All implementations of the vendor-independent FOMAU shall be compatible at the FOMDI and at the AUI (when physically and mechanically implemented).

This standard provides an optical fiber cable link segment specification for the interconnection of only two FOMAU devices. The medium itself, the functional capability of the FOMAU, and the AUI are defined to provide the highest possible level of compatibility among devices designed by different manufacturers. Designers are free to implement circuitry within the FOMAU in an application-dependent manner provided the FOMDI and AUI are satisfied. (The provision of the physical and mechanical implementation of the AUI is optional.)

### 9.9.1.4 Relationship to AUI

A close relationship exists between this subclause and Clause 7. This subclause specifies all of the physical medium parameters, all of the FOPMA logical functions residing in the FOMAU, and references the AUI defined in Clause 7 with the exception of the *signal\_quality\_error* message Test of 7.2.1.2.3(3), which shall not be implemented, that is, shall not be enabled when connected to a repeater unit.

NOTE—The specification of a FOMAU component requires the use of both this subclause and Clause 7 for the AUI specifications.

### 9.9.1.5 Mode of operation

The FOMAU functions as a direct connection between the optical fiber cable link segment and the repeater unit. During collision-free operation, data from the repeater unit is transmitted into the FOMAU's transmit optical fiber, and all data in the FOMAU's receive optical fiber is transmitted to the repeater unit.

## 9.9.2 FOMAU functional specifications

The FOMAU component provides the means by which signals on the three AUI signal circuits are coupled:

- a) From the repeater unit into the FOMAU's transmit optical fiber, and
- b) From the FOMAU's receive optical fiber to the repeater unit.

To achieve this basic objective, the FOMAU component contains the following functional capabilities to handle message flow between the repeater unit and the optical fiber cable link segment:

- a) *Transmit function:* The ability to receive serial bit streams from the attached repeater unit and transmit them into the FOMAU's optical fiber.

- b) *Receive function:* The ability to receive serial data bit streams from the FOMAU's receive optical fiber and transmit them to the attached repeater unit.
- c) *Collision Presence function:* The ability to detect, and report to the attached repeater unit, an FOIRL collision.
- d) *Jabber function:* The ability to automatically interrupt the Transmit function and inhibit an abnormally long output data stream.
- e) *Low Light Level Detection function:* The ability to automatically interrupt the Receive function and inhibit the reception of signals from the FOMAU's receive optical fiber which could result in abnormally high BERs.

### 9.9.2.1 Transmit function requirements

At the start of a packet transmission into the FOMAU's transmit optical fiber, no more than two bits (two full bit cells) of information may be received from the DO circuit and not transmitted into the FOMAU's transmit optical fiber. In addition, it is permissible for the first bit sent to contain encoded phase violations or invalid data. All successive bits of the packet shall be transmitted into the FOMAU's transmit optical fiber and shall exhibit the following:

- a) No more edge jitter than that given by the sum of the worst-case edge jitter components specified in 7.4.3.6, 7.5.2.1, and 9.9.4.1.7, and
- b) The levels and waveforms specified in 9.9.4.1.

The FOMAU DO circuit shall comply with the AUI specification for receivers given in 7.4.2. The FOMAU's DI circuit driver shall comply with the AUI specification for drivers given in 7.4.1.

The steady-state propagation delay between the DO circuit receiver input and the FOMAU's transmit optical fiber input shall not exceed one-half a bit cell. It is recommended that the designer provide an implementation in which a minimum threshold level is required on the DO circuit to establish a transmit bit stream.

The higher optical power level transmitted into the FOMAU's transmit optical fiber shall be defined as the low (LO) logic state on the optical fiber link segment. There shall be no logical signal inversions between the DO circuit and the FOMAU's transmit optical fiber, as specified in 9.9.4.1.5.

The difference in the start-up delay (bit loss plus invalid bits plus steady-state propagation delay), as distinct from the absolute start-up delays, between any two packets that are separated by 9.6  $\mu$ s or less shall not exceed 2 bit cells.

The FOMAU shall loop back a packet received from the DO circuit into the DI circuit. At the start of a packet transmission, no more than five bits of information may be received from the DO circuit and not transmitted into the DI circuit. It is permissible for the first bit sent to contain encoded phase violations or invalid data. All successive bits of the packet shall be transmitted into the DI circuit and shall exhibit no more edge jitter than that specified for signals transmitted into the DI circuit by the Receive function, as specified in 9.9.2.2. The steady-state propagation delay between the DO circuit receiver input and the DI circuit driver output for such signals shall not exceed one bit cell. There shall be no logical signal inversions between the DO circuit and the DI circuit during collision-free transmission.

When the DO circuit has gone idle after a packet has been transmitted into the FOMAU's transmit optical fiber, the FOMAU shall not activate the Collision Presence function so as not to send the *signal\_quality\_error* message Test of 7.2.1.2.3(3) to the repeater unit.

During the idle state of the DO circuit, the Transmit function shall output into the transmit optical fiber an optical idle signal as specified in 9.9.4.1.4. The transmitted optical signals shall exhibit the optical power levels specified in 9.9.4.1.8. At the end of a packet transmission, the first optical idle signal pulse transition

to the higher optical power level must occur no sooner than 400 ns and no later than 2100 ns after the packet's last transition to the lower optical power level. This first optical pulse must meet the timing requirements of 9.9.4.1.4.

The FOMAU shall not introduce extraneous optical signals into the transmit optical fiber under normal operating conditions, including powering-up or powering-down of the FOMAU.

### 9.9.2.2 Receive function requirements

At the start of a packet reception from the FOMAU's receive optical fiber, no more than two bits (two full bit cells) of information may be received from the FOMAU's receive optical fiber and not transmitted into the DI circuit. It is permissible for the first bit transmitted into the DI circuit to contain encoded phase violations or invalid data. All successive bits of the packet shall be transmitted into the DI circuit and shall exhibit the following:

- a) The levels and waveforms specified in 7.4.1, and
- b) No more edge jitter than that given by the sum of the worst-case edge jitter components specified in 7.4.3.6, 7.5.2.1, 9.9.4.1.7, 9.9.4.2.2, and 9.9.5.1.

The steady-state propagation delay between the output of the FOMAU's receive optical fiber and the output of the DI circuit driver shall not exceed one-half a bit cell. There shall be no logical signal inversions between the FOMAU's receive optical fiber and the DI circuit during collision-free operation, as specified in 9.9.4.2.3.

The difference in the start-up delay (bit loss plus invalid bits plus steady-state propagation delay), as distinct from the absolute start-up delays, between any two packets that are separated by 9.6  $\mu$ s or less shall not exceed 2 bit cells.

The FOMAU shall not introduce extraneous signals into the DI circuit under normal operating conditions, including powering-up or powering-down of the FOMAU.

### 9.9.2.3 Collision Presence function requirements

The signal presented to the CI circuit in the absence of an SQE signal shall be the IDL signal.

The signal presented to the CI circuit during the presence of a collision shall be the CS0 signal, a periodic pulse waveform of frequency 10 MHz +25% –15% with pulse transitions that are no less than 35 ns and no greater than 70 ns apart at the zero crossing points. This signal shall be presented to the CI circuit no more than 3.5 bit times after the simultaneous appearance of signals at both the input of the FOMAU's transmit optical fiber and the output of the FOMAU's receive optical fiber. This signal shall be de-asserted no earlier than 4.5 bit times and no later than 7 bit times after the above defined collision condition ceases to exist.

During a collision, if a packet is received at the DO circuit before a packet is received at the FOMAU's receive optical fiber, then only the packet received at the DO circuit shall be transmitted into the DI circuit, as specified in 9.9.2.1. Conversely, if during a collision a packet is received at the FOMAU's receive optical fiber before a packet is received at the DO circuit, then only the packet received at the FOMAU's receive optical fiber shall be transmitted into the DI circuit, as specified in 9.9.2.2. In the event of both packets being received at their respective ports within 3.5 bit times of each other, then either one, but only one, of the packets shall be selected to be transmitted into the DI circuit.

The Collision function shall not introduce extraneous signals into the CI circuit under normal operating conditions, including powering-up or powering-down of the FOMAU.

#### 9.9.2.4 Jabber function requirements

The FOMAU shall have the capability, as defined in Figure 9–9, to interrupt a transmission from the repeater unit that exceeds a time duration determined by the FOMAU. This time duration shall not be less than 20 ms nor more than 150 ms. If the packet being transmitted is still being transmitted after the specified time duration, the FOMAU shall activate the Jabber function by the following:

- a) First inhibiting the transmission of bits from its DO circuit into its transmit optical fiber,
- b) Then transmitting into its transmit optical fiber the optical idle signal specified in 9.9.4.1.4, and
- c) Presenting the CS0 signal to the CI circuit.

Once the error condition has been cleared, the FOMAU shall reset the Jabber function and present the IDL signal to the CI circuit:

- a) On power reset, and
- b) Optionally, automatically after a continuous period of  $0.5\text{ s} \pm 50\%$  of inactivity on the DO circuit.

The FOMAU shall not activate its Jabber function when operated under the worst-case Jabber Lockup Protection condition specified in 9.6.5.

When both the Jabber function and the Low Light Level Detection function (see 9.9.2.5) have been activated, the Jabber function shall override the Low Light Level Detection function.

#### 9.9.2.5 Low Light Level Detection function requirements

The FOMAU shall have a low light level detection capability, as defined in Figure 9–10, whereby it shall interrupt the reception of both the optical idle signal and packets from the FOMAU's receive optical fiber when reliable reception can no longer be assured. This error condition shall not be activated if the peak optical power level at the output of the FOMAU's receive optical fiber exceeds  $-27\text{ dBm}$ . It shall be activated before the peak optical power level at the output of the FOMAU's receive optical fiber has fallen to a level that is lower than the peak optical power level that corresponds to a  $\text{BER} = 10^{-10}$  for the FOMAU under consideration. Once this error condition has been activated, the FOMAU shall, no earlier than 30 bit times and no later than 200 bit times

- a) Disable its Receive function so that the transmission of bits from its receive optical fiber to the DI circuit is inhibited.
- b) Assure that only the optical idle signal is transmitted into its transmit optical fiber, irrespective of the state of the DO circuit.
- c) Disable its Transmit function during the period of time that the FOMAU recognizes the presence of a packet on the DO circuit such that the transmission of the packet from the DO circuit into the DI circuit is inhibited.

Once this error condition has been cleared, the FOMAU shall return automatically to its normal mode of operation within 40 bit times once the DO circuit is in the idle state.

When both the Jabber function (see 9.9.2.4) and the Low Light Level Detection function have been activated, the Jabber function shall override the Low Light Level Detection function.

NOTE—It is recommended that, for diagnostic purposes, the status of the Low Light Level Detection function be indicated on the exterior of the FOMAU package.

### 9.9.2.6 Repeater Unit to FOMAU physical layer messages

The following messages can be received by the FOMAU physical layer entities from the repeater unit:

Message	Circuit	Signal	Meaning
output	DO	CD1, CD0	Output information
output_idle	DO	IDL	No data to be output

### 9.9.2.7 FOMAU physical layer to repeater unit messages

The following messages can be sent by the FOMAU physical layer entities to the repeater unit:

Message	Circuit	Signal	Meaning
<b>input</b>	<b>DI</b>	<b>CD1, CD0</b>	<b>Input information</b>
input_idle	DI	IDL	No information to be input
fomau_available	CI	IDL	FOMAU is available for output
signal_quality_error	CI	CS0	Collision or error detected by FOMAU

#### 9.9.2.7.1 *input* message

The FOMAU physical layer sends an *input* message to the repeater unit when the FOMAU has a bit of data to send to the repeater unit. The physical realization of the *input* message is a CD0 or CD1 sent by the FOMAU to the repeater unit on the DI circuit. The FOMAU sends CD0 if the input bit is a zero, or CD1 if the input bit is a one. No retiming of the CD1 or CD0 signals takes place within the FOMAU.

#### 9.9.2.7.2 *input\_idle* message

The FOMAU physical layer sends an *input\_idle* message to the repeater unit when the FOMAU does not have data to send to the repeater unit. The physical realization of the *input\_idle* message is the IDL signal sent by the FOMAU to the repeater unit on the DI circuit.

#### 9.9.2.7.3 *fomau\_available* message

The FOMAU physical layer sends the *fomau\_available* message to the repeater unit when the FOMAU is available for output, and when the FOMAU has activated the Low Light Level Detection function in accordance with the Low Light Level Detection function requirements of 9.9.2.5 and Figure 9–10. The *fomau\_available* message shall be sent by a FOMAU that is prepared to output data. The physical realization of the *fomau\_available* message is an IDL signal sent by the FOMAU to the repeater unit on the CI circuit.

#### 9.9.2.7.4 *signal\_quality\_error* message

The *signal\_quality\_error* message shall be implemented in the following fashion:

- a) When the FOMAU has completed the transmission of a packet into its transmit optical fiber, it shall not send any *signal\_quality\_error* message Test sequence.

- b) The simultaneous appearance of packets at both the input of a FOMAU's transmit optical fiber and the output of its receive optical fiber shall cause the *signal\_quality\_error* message to be sent by the FOMAU to the repeater unit.
- c) When the FOMAU has activated the Jabber function, it shall send the *signal\_quality\_error* message in accordance with the Jabber function requirements of 9.9.2.4 and Figure 9–9.

The physical realization of the *signal\_quality\_error* message is the CS0 signal sent by the FOMAU to the repeater unit on the CI circuit.

The FOMAU is required to assert the *signal\_quality\_error* message at the appropriate times whenever the FOMAU is powered and not just when the repeater unit is providing output data.

### 9.9.2.8 FOMAU state diagrams

The state diagrams, Figure 9–8, Figure 9–9, and Figure 9–10, depict the full set of allowed FOMAU state functions relative to the control circuits of the repeater unit/FOMAU interface for FOMAUs. Messages used in these state diagrams are explained as follows:

NOTE—Figures 9–8, 9–9, and 9–10 must all be considered together.

- a) *enable\_opt\_driver* : Activates the path employed during normal operation to cause the FOMAU transmitter to impress the packet data received from the DO circuit into the FOMAU's transmit optical fiber.
- b) *disable\_opt\_driver* : Deactivates the path employed during normal operation to cause the FOMAU transmitter to impress the packet data received from the DO circuit into the FOMAU's transmit optical fiber.
- c) *enable\_opt\_idle\_driver* : Causes the FOMAU transmitter to impress the optical idle signal into the FOMAU's transmit optical fiber.
- d) *disable\_opt\_idle\_driver* : Causes the FOMAU to stop transmitting the optical idle signal into the FOMAU's transmit optical fiber.
- e) *enable\_loop\_back* : Activates the path employed during normal operation to cause the FOMAU Transmit function to impress the packet data received from the DO circuit into the DI circuit.
- f) *disable\_loop\_back* : Deactivates the path employed during normal operation to cause the FOMAU Transmit function to impress the packet data received from the DO circuit into the DI circuit.
- g) *enable\_opt\_receiver* : Activates the path employed during normal operation to cause the FOMAU to impress the packet data received from the FOMAU's receive optical fiber into the DI circuit.
- h) *disable\_opt\_receiver* : Deactivates the path employed during normal operation to cause the FOMAU to impress the packet data received from the FOMAU's receive optical fiber into the DI circuit.
- i) [*start\_packet\_timer*] : Starts a timing function which is used to monitor the amount of time the FOMAU is transmitting a packet into the transmit optical fiber. The timing function is maintained as long as *output* is true and is stopped on the transition to *output\_idle true*. The term *packet\_timer\_done* is satisfied when the timing function has run to expiration (see 9.9.2.4).
- j) [*start\_unjab\_timer*] : Starts a timing function that is used to monitor the amount of time that the Jabber error condition has been clear. The timing function is maintained as long as *output\_idle* is true and is stopped on the transition to *output true*. The term *unjab\_timer\_done* is satisfied when the timing function has run to expiration (see 9.9.2.4).



- k) *opt\_input* : Signifies that a packet is present at the FOMAU's receive optical fiber.
- l) *opt\_input\_idle* : Signifies that a packet is no longer present at the FOMAU's receive optical fiber.
- m) *opt\_input\_coll\_select* : Signifies that, during a collision, a packet has been received at the DO circuit within 3.5 bit times of a packet being received at the FOMAU's receive optical fiber, and that only the packet received at the FOMAU's receive optical fiber is to be transmitted into the DI circuit.
- n) *output\_coll\_select* : Signifies that, during a collision, a packet has been received at the DO circuit within 3.5 bit times of the packet being received at the FOMAU's receive optical fiber, and that only the packet received at the DO circuit is to be transmitted into the DI circuit.

The following abbreviations have been used in Figure 9–8, Figure 9–9, and Figure 9–10:

- LLP = Low Light Level Condition Present
- LLNP = Low Light Level Condition Not Present
- p\_t\_d = *packet\_timer\_done*
- p\_t\_n\_d = *packet\_timer\_not\_done*
- \* = logical AND operator

### 9.9.3 FOMAU electrical characteristics

#### 9.9.3.1 Electrical isolation

Electrical isolation shall be provided between FOMAUs attached to the FOIRL by the optical fiber cable link segment. There shall be no conducting path between the optical medium connector plug and any conducting element within the optical fiber cable link segment. This isolation shall withstand at least one of the following electrical strength tests:

- a) 1500 V rms at 50–60 Hz for 60 s, applied as specified in 5.3.2 of IEC 60950: 1991.
- b) 2250 V dc for 60 s, applied as specified in 5.3.2 of IEC 60950: 1991.
- c) A sequence of ten 2400 V impulses of alternating polarity, applied at intervals of not less than 1 s. The shape of the impulses shall be 1.2/50  $\mu$ s (1.2  $\mu$ s virtual front time, 50  $\mu$ s virtual time of half value), as defined IEC 60060.

There shall be no isolation breakdown, as defined in 5.3.2 of IEC 60950: 1991, during the test. The resistance after the test shall be at least 2 M $\Omega$ , measured at 500 V dc.

NOTE—Although isolation is provided by the optical fiber cable link segment, it is recommended that the normal noise immunity provided by common-mode isolation on the AUI be retained.

#### 9.9.3.2 Power consumption

The current drawn by the FOMAU shall not exceed 0.5 A when powered by the AUI source. The FOMAU shall be capable of operating from all possible voltage sources as supplied by the repeater unit (7.5.2.5 and 7.5.2.6) through the resistance of all permissible AUI cables. The surge current drawn by the FOMAU on power-up shall not exceed 5 A peak for a period of 10 ms. In addition, the FOMAU shall be capable of powering-up from 0.5 A current limited sources.

It is permissible as an option to provide a separate power source for the FOMAU. If a separate power source is implemented, provision will be made to assure that power shall under no circumstances be sourced on pin 13 (Circuit VP) of the AUI.

The FOMAU shall be labeled externally to identify the maximum value of power supply current required by the device when the AUI mechanical connection is implemented.

The FOMAU shall not introduce into the FOMAU's transmit optical fiber or onto the DI or CI circuits of the AUI any extraneous signal on routine power-up or power-down under normal operating conditions.

The FOMAU shall be fully functional no later than 0.5 s after power is applied to it.

### **9.9.3.3 Reliability**

The FOMAU shall be designed to provide a MTBF of at least 200 000 hours of operation without causing a communication failure amongst DTEs attached to the network. The FOMAU electronics shall be designed to minimize the probability of component failures within the FOMAU that prevent communication amongst other MAUs on the 10BASE5 and 10BASE2 segments. Connectors and other passive means of connection shall be designed to minimize the probability of total network failure.

### **9.9.3.4 FOMAU/Repeater unit electrical characteristics**

The electrical characteristics of the driver and receiver components connected to the AUI cable shall be identical to those specified in Clause 7.

### **9.9.3.5 FOMAU/Repeater unit mechanical connection**

The FOMAU, if it implements the AUI mechanical connection, shall be provided with a 15-pin male connector, as specified in the AUI specification of Clause 7.

## **9.9.4 FOMAU/Optical medium interface**

### **9.9.4.1 Transmit optical parameters**

#### **9.9.4.1.1 Wavelength**

The center wavelength of the optical source emission shall be between 790 nm and 860 nm. See 15.2.1.1.

#### **9.9.4.1.2 Spectral width**

The spectral width of the optical source shall be less than 75 nm full width half maximum (FWHM).

#### **9.9.4.1.3 Optical modulation**

The optical modulation during packet transmission shall be on-off keying of the optical source power. The minimum extinction ratio shall be 13 dB.

#### **9.9.4.1.4 Optical idle signal**

During the idle state of the DO circuit, the Transmit function shall input into the FOMAU's transmit optical fiber an optical idle signal. This signal shall consist of a periodic pulse waveform of frequency 1 MHz +25% -15% with a duty cycle ratio between 45/55 and 55/45.

#### **9.9.4.1.5 Transmit optical logic polarity**

The higher optical power level transmitted into the FOMAU's transmit optical fiber shall correspond to the low (LO) logic state (see 7.4.2.1) of the AUI DO circuit.

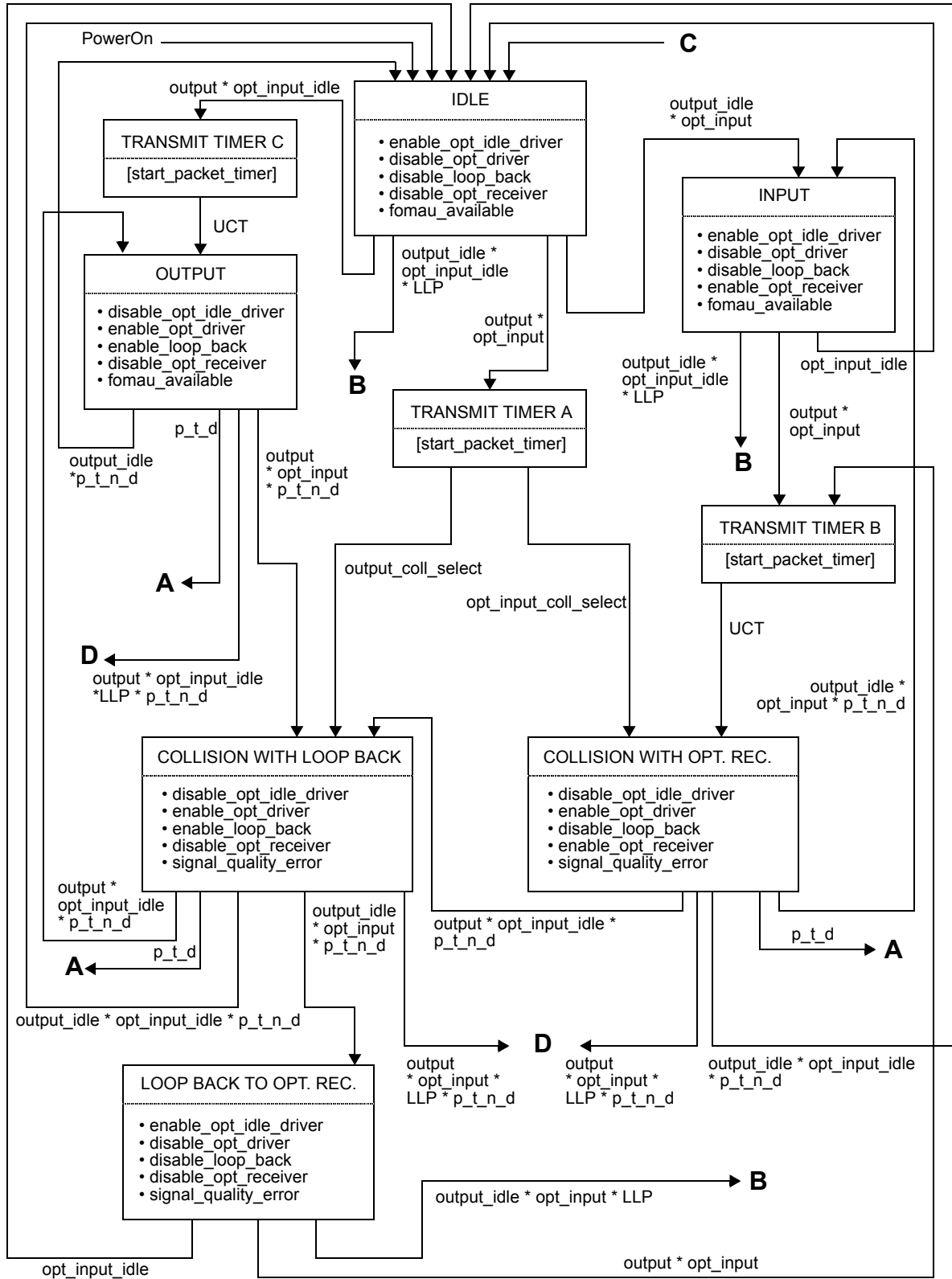
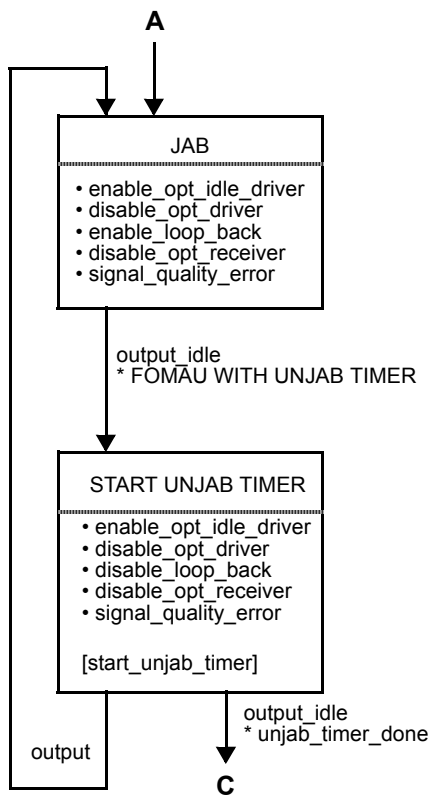
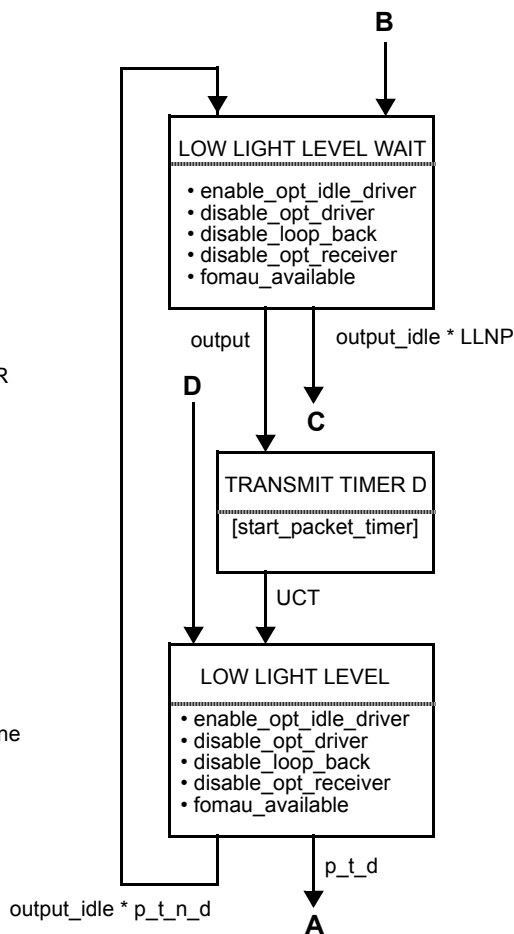


Figure 9-8—FOMAU Transmit, Receive, and Collision functions state diagram



**Figure 9-9—  
FOMA Jabber function  
state diagram**



**Figure 9-10—  
Low Light Level Detection  
function state diagram**

#### 9.9.4.1.6 Optical rise and fall times

The optical rise and fall times of the FOMA shall be no more than 10 ns from the 10% to the 90% levels. There shall be no more than 3 ns difference between the rise and fall times.

#### 9.9.4.1.7 Transmit optical pulse edge jitter

The additional edge jitter introduced by the FOMA from the input of the DO circuit receiver to the output of the electro-optic source shall be no more than 2 ns. The jitter measured at the input of the DO circuit receiver shall be measured at the zero crossing points, as determined from the previous 16 or more transitions in any valid bit stream. The jitter measured at the output of the electro-optic source shall be measured at the power level median of the optical waveform's upper and lower power levels, as determined from the previous 16 or more transitions in any valid optical bit stream.

#### 9.9.4.1.8 Peak coupled optical power

At the beginning of the FOMAU's lifetime, the peak optical power coupled into the FOMAU's transmit optical fiber, when terminated with an optical connector as specified in 9.9.5.2, shall be  $-12 \text{ dBm} \pm 2 \text{ dB}$ , when measured with a graded index optical fiber of nominal dimension of  $62.5 \text{ }\mu\text{m}$  core diameter and 0.275 nominal numerical aperture. The actual optical power, which will be coupled into other fiber sizes listed in 9.9.5.1, may differ from the above value. The peak optical power shall be measured in the steady state, and the measurement shall be independent of optical pulse ringing effects. Peak optical overshoot shall not exceed 10%.

NOTE 1—The source is allocated an aging margin of 3 dB over its operating lifetime. Thus, with respect to an optical fiber of nominal dimension of  $62.5 \text{ }\mu\text{m}$  core diameter and 0.275 nominal numerical aperture, the minimum launch peak power at the end of life is  $-17 \text{ dBm}$  and the maximum initial launch peak power is  $-10 \text{ dBm}$ . The variation in the peak coupled optical power into any of the optical fibers specified in 9.9.5.1 is  $\pm 1 \text{ dB}$  with respect to the above-mentioned nominal optical fiber. Hence, with respect to any of the optical fibers specified in 9.9.5.1, the minimum possible launch peak power at the end of life is  $-18 \text{ dBm}$  and the maximum possible initial launch peak power is  $-9 \text{ dBm}$ . The start of life minimum possible launch peak power is then  $-15 \text{ dBm}$ .

NOTE 2—The transmit optical power range specified above is the power coupled into the core of the optical fiber. Typical current fibers require 1 m to 5 m to remove optical power from the cladding. For links under 5 m in length, it may be necessary to use techniques such as attenuators or mode-stripping filters to attenuate optical power coupled into the cladding in order to meet the requirements of 9.9.4.2.1.

#### 9.9.4.2 Receive optical parameters

##### 9.9.4.2.1 Receive peak optical power range

The BER shall be  $< 10^{-10}$  for peak optical powers at the output of the FOMAU's receive optical fiber between  $-27 \text{ dBm}$  and  $-9 \text{ dBm}$ .

##### 9.9.4.2.2 Receive optical pulse edge jitter

The additional edge jitter introduced by the FOMAU from the input of the opto-electric detector to the output of the DI circuit driver shall be no more than 4 ns. The jitter measured at the input of the opto-electric receiver shall be measured at the power level median of the optical waveform's upper and lower power levels as determined from the previous 16 or more transitions in any valid optical bit stream. The jitter measured at the output of the DI circuit driver shall be measured at the zero crossing points as determined from the previous 16 or more transitions in any valid bit stream. This requirement shall apply when the optical receive peak power level is in the range  $-27$  to  $-9 \text{ dBm}$ .

##### 9.9.4.2.3 Receive optical logic polarity

The low (LO) logic state (see 7.4.2.1) on the DI circuit shall correspond to the presence of the higher optical power level at the output of the FOMAU's receive optical fiber.

#### 9.9.5 Characteristics of the optical fiber cable link segment

The optical fiber cable link segment is a length of optical fiber cable (IEC 60794-1: 1993 and IEC 60794-2: 1989) containing two optical fibers, as specified in 9.9.5.1, and comprising one or more optical fiber cable sections and their means of interconnection. Each optical fiber is terminated at each end in the optical connector plug specified in 9.9.5.2. The two optical fibers correspond to the FOMAU's transmit and receive optical fibers.

### 9.9.5.1 Optical fiber medium

The FOMAU can operate with a variety of optical fiber sizes, e.g., 50/125  $\mu\text{m}$ , 62.5/125  $\mu\text{m}$ , 85/125  $\mu\text{m}$ , 100/140  $\mu\text{m}$ .

Interoperability of FOMAUs that originate from different manufacturers, using any of these fiber sizes, is assured provided that the received peak optical power is between  $-27$  dBm and  $-9$  dBm and the optical fiber cable link segment bandwidth is greater than or equal to 150 MHz.

In order to satisfy the above attenuation and bandwidth criteria for all allowable FOIRL lengths, and assuming up to 4 dB of connection losses within the optical fiber cable link segment, it is recommended that the cabled optical fiber have an attenuation  $\leq 4$  dB/km and a bandwidth of  $\geq 150$  MHz referred to 1 km at a wavelength of 850 nm.

The total incremental optical pulse edge jitter introduced by the optical fiber cable link segment shall be less than 1 ns when driven by an optical transmitter as specified in 9.9.4.1. The pulse delay introduced by the optical fiber cable shall not exceed 50 bit times for a 1 km length.

In the specific case of 62.5/125  $\mu\text{m}$  fiber, to ensure interoperability of FOMAUs that originate from different manufacturers:

- a) The two cabled optical fibers contained in the optical fiber cable link segment shall satisfy the optical fiber parameters specified in IEC 60793-2: 1992 type A1b (62.5/125  $\mu\text{m}$ ), and
- b) The optical fiber cable link segment shall have an attenuation less than or equal to 8 dB and a bandwidth greater than or equal to 150 MHz.

NOTE—For newer fiber installations, it is recommended that the requirements of 15.3 be used.

### 9.9.5.2 Optical medium connector plug and socket

The two optical fibers contained in the optical fiber cable link segment shall be terminated at each end in an optical connector plug as specified in IEC 60874-1: 1993 and 60874-2: 1993.

The corresponding mating connector socket shall conform with the specifications given in IEC 60874-1: 1993 and 60874-2: 1993. This document specifies the mechanical mating face dimensions to ensure mechanical intermateability without physical damage, of all F-SMA connectors covered by the document. In addition, the optical insertion loss when interconnecting two optical connector plugs shall not exceed 2.5 dB (measured using a socket adaptor conforming to the mechanical specifications given in IEC 60874-1: 1993 and 60874-2: 1993 and also using two identical fibers, as specified in 9.9.5.1, assuming uniform mode distribution launch conditions).

## 9.9.6 System requirements

### 9.9.6.1 Optical transmission system considerations

Subclause 9.9.4.2.1 specifies that the BER shall be  $<10^{-10}$  for peak optical powers at the output of the FOMAU's receive optical fiber between  $-27$  dBm and  $-9$  dBm. The value of  $-9$  dBm corresponds to the maximum allowable peak optical power that can be coupled into the worst-case optical fiber specified in 9.9.5.1 at the beginning of the FOMAU's lifetime (see 9.9.4.1.8), and assumes zero optical loss between the optical source output and the optical detector input.

The value of  $-27$  dBm is calculated by subtracting the FOIRL flux budget from the minimum allowable peak optical power that can be coupled into the FOMAU's transmit optical fiber at the beginning of the FOMAU's lifetime (see 9.9.4.1.8). The flux budget is the maximum loss allowed within the FOIRL to guar-

antee a BER  $< 10^{-10}$  assuming worst-case link components. A portion of the flux budget has been allocated as a design margin to allow for degradation and tolerance effects in the optical source. This is noted in the table below as the optical source lifetime degradation. The remaining flux budget of 9 dB assumes a system margin allowance for the optical fiber cable link segment over its lifetime, and may be allocated to the optical fiber cable link segment loss at the discretion of the network planner/installer. The following summarizes the allocated optical flux budgets for the example graded index optical fiber of worst-case dimensions 62.5  $\mu\text{m}$  – 3  $\mu\text{m}$  (i.e., 59.5  $\mu\text{m}$ ) core diameter and 0.275 – 0.015 (i.e., 0.260) numerical aperture:

Start of life minimum peak coupled optical power (9.9.4.1.8)	: –15 dBm
Optical source lifetime degradation	: 3 dB
Maximum optical fiber cable link segment loss including system margin allowance	: 9 dB
Resultant required receive peak optical power	: –27 dBm

### 9.9.6.2 Timing considerations

Table 9–4 summarizes the maximum allowable timing budget contributions to the system timing budget for the FOIRL. The last bit in to last bit out delay shall equal the Steady-State Propagation Delay.

**Table 9–4—Maximum allowable timing budget contributions to the FOIRL system timing budget**

Symbol	Function	Bit loss (bit times)	Invalid bits (bit times)	Steady-state propagation delay (bit times)	Start-up delay (bit times)
I1	OPTICAL DATA IN ASSERT→INPUT	2.0	1.0	0.5	3.5
I2	OUTPUT→OPTICAL DATA OUT ASSERT	2.0	1.0	0.5	3.5
LOOP BACK	DO CIRCUIT ASSERT →DI CIRCUIT ASSERT	5.0	1.0	1.0	7.0
I3	OPTICAL COLLISION →SQE ASSERT	—	—	—	3.5
I4	COLLISION DE-ASSERT →SQE DE-ASSERT	—	—	—	7.0 <sup>a</sup>
A1	AUI propagation	—	—	2.57	2.57
F1	Optical fiber propagation per kilometer	—	—	50	50

<sup>a</sup>Minimum start-up delay for I4 is 4.5 bit times.

## **9.9.7 Environmental specifications**

### **9.9.7.1 Safety requirements**

#### **9.9.7.1.1 Electrical safety**

A major application for the vendor-independent FOIRL is interconnecting electrically conductive cable segments located within different buildings. The level of isolation provided by the optical fiber cable link segment shall be consistent with this application and provide adequate personnel and equipment safety from earth faults and lightning strike hazards.

#### **9.9.7.1.2 Optical source safety**

The recommendations of IEC 60825: 1993, if applicable, shall be adhered to in determining the optical source safety and user warning requirements.

### **9.9.7.2 Electromagnetic environment**

#### **9.9.7.2.1 Susceptibility levels**

Sources of interference from the environment include electromagnetic fields, electrostatic discharge, and transient voltages between earth connections. Several sources of interference contribute to voltage between the optical fiber cable link segment (either a metallic strength member in the cable, a metallic optical connector plug, or the outermost conducting element of the FOMAU for the case of no metallic strength member) and the earth connection of a DTE.

For information on limits and methods of measurements of radio interference characteristics of information technology equipment, see 1.3 in CISPR 22: 1993.

The physical channel hardware shall meet its specifications when operating in both of the following conditions:

- a) Ambient plane wave field of 2 V/m from 10 kHz through 30 MHz and 5 V/m from 30 MHz through 1 GHz.

NOTE—These are the levels typically found 1 km from radio broadcast stations.

- b) Interference source voltage of 15.8 V peak sine wave of frequency 10 MHz in series with a 50  $\Omega$  source resistance applied between the optical fiber cable link segment (either a metallic strength member in the cable, a metallic optical connector plug, or the outermost conducting element of the FOMAU for the case of no metallic strength member) and the earth connection of a DTE.

NOTE—The optical fiber link segment is capable of withstanding higher levels of electromagnetic interference. The above specifications are the minimum requirements for the environment in which the FOMAU is required to operate.

#### **9.9.7.2.2 Emission levels**

The FOMAU and optical fiber cable link segment shall comply with CISPR 22: 1993.



### **9.9.7.3 Temperature and humidity**

The FOMAU and associated connector/cable systems are expected to operate over a reasonable range of environmental conditions related to temperature, humidity, and physical handling such as shock and vibration. Specific requirements and values for these parameters are beyond the scope of this standard. Manufacturers should indicate in the literature associated with the FOMAU (and on the FOMAU if possible) the operating environment specifications to facilitate selection, installation, and maintenance of these components. It is further recommended that such specifications be stated in standard terms, as specified in IEC 60068, IEC 60793-1: 1992, IEC 60794-1: 1993, and IEC 60874-1: 1993.

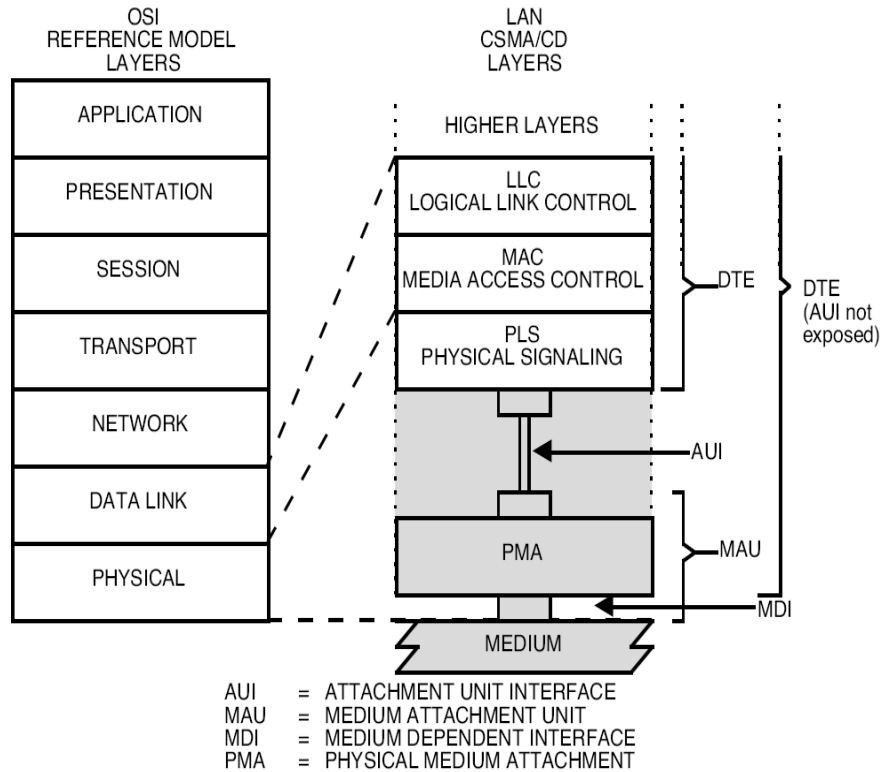


## 10. Medium attachment unit and baseband medium specifications, type 10BASE2

### 10.1 Scope

#### 10.1.1 Overview

This standard defines the functional, electrical, and mechanical characteristics of the Medium Attachment Unit (MAU) and one specific medium for use with LANs. The relationship of this specification to the entire ISO/IEC 8802-3 CSMA/CD LAN International Standard is shown in Figure 10–1.



**Figure 10–1—Physical Layer partitioning, relationship to the ISO/IEC Open Systems Interconnection (OSI) reference model**

The purpose of the MAU is to provide a simple, inexpensive, and flexible means of attaching devices to the LAN medium. This standard defines a means of incorporating the MAU function within the DTE and bringing the trunk coaxial cable directly to the DTE. Interconnection of DTE units is easily achieved by the use of industry standard coaxial cables and BNC connectors.

This MAU and medium specification is aimed primarily at applications where there are a relatively small number of devices located in a work area. Installation and reconfiguration simplicity is achieved by the type of cable and connectors used. An inexpensive implementation is achieved by eliminating the MAU and Attachment Unit Interface (AUI) as separate components and using widely available interconnection components.

### **10.1.1.1 Medium attachment unit (normally contained within the data terminal equipment [DTE])**

The MAU has the following general characteristics:

- a) Enables coupling the PLS to the explicit baseband coaxial transmission system defined in this clause of the standard.
- b) Supports message traffic at a data rate of 10 megabits per second (Mb/s).
- c) Provides for driving up to 185 m coaxial trunk cable segment without a repeater.
- d) Permits the DTE to test the MAU and the medium itself.
- e) Supports system configurations using the CSMA/CD access mechanism defined in IEEE 802.3.
- f) Supports a bus topology interconnection means.
- g) Supports low-cost capability by incorporating the MAU function within the physical bounds of the DTE, thereby eliminating the need for a separate AU connector and cable but containing the remaining AU interface functionality.

### **10.1.1.2 Repeater unit**

The Repeater Unit is used to extend the physical system topology and provides for coupling two or more coaxial trunk cable segments. Multiple Repeater Units are permitted within a single system to provide the maximum trunk cable connection path specified in 10.7. The repeater is not a DTE and therefore has slightly different attachment requirements.

### **10.1.2 Definitions**

See 1.4.

### **10.1.3 Application perspective: MAU and medium objectives**

This subclause states the broad objectives and assumptions underlying the specifications defined throughout Clause 10 of the standard.

#### **10.1.3.1 Object**

- a) Provide the physical means for communication between local network Data Link entities.  
  

NOTE—This specification covers a portion of the Physical Layer as defined in the OSI Reference Model and, in addition, the physical medium itself, which is beyond the scope of the OSI Reference Model.
- b) Define a physical interface that can be implemented independently among different manufacturers of hardware and achieves the intended level of compatibility when interconnected in a common local network.
- c) Provide a communication channel capable of high bandwidth and low bit error ratio performance. The resultant mean bit error ratio, at the Physical Layer service interface, should be less than one part in  $10^7$  (on the order of one part in  $10^8$  at the link level).
- d) Provide for ease of installation and service.
- e) Provide for high network availability (ability of a station to gain access to the medium and enable the Data Link connection in a timely fashion).
- f) Enable low-cost implementations.

NOTE—The figures and numerous textual references throughout this clause refer to terminology associated with the AUI (that is, DO, DI, CI). Since the normal embodiment of the type 10BASE2 configuration does not require an AUI, actual existence of the DO, DI, CI circuit may not be required. Use of this terminology, however, is retained throughout Clause 10 for purposes of clarity and consistency.

### 10.1.3.2 Compatibility considerations

All implementations of this baseband coaxial system shall be compatible at the Medium Dependent Interface (MDI).

This standard provides one explicit trunk cable medium specification for the interconnection of all MAU devices. The medium itself, and the functional capability of the MAU, are defined to provide the highest possible level of compatibility among devices designed by different manufacturers. Designers are free to implement circuitry within the MAU in an application-dependent manner provided the MDI specifications are satisfied.

### 10.1.3.3 Relationship to PLS and AUI

This clause defines the Primary Physical Layer for the LAN, a layer comprised of both the physical medium and the rudimentary circuitry necessary to couple a station's message path directly to/from the medium. The complete Logical Physical Layer of the LAN resides within the DTE. Therefore, a close relationship exists between this subclause and Clause 7. This subclause specifies the physical medium parameters, the PMA logical functions residing in the MAU, and references the signal circuits associated with the AUI as defined in Clause 7.

The design of a MAU component requires the use of both this clause and parts of the PLS and AUI specifications contained in Clause 7.

### 10.1.3.4 Mode of operation

The MAU functions as a direct connection between the baseband medium and the DTE. Data from the DTE is output to the coaxial trunk medium and all data on the coaxial trunk medium is input to the DTE.

## 10.2 References

References to such local or national standards that may be useful resource material for the reader are identified and located in Annex A.

## 10.3 MAU functional specifications

The MAU component provides the means by which signals on the three AUI signal circuits to/from the DTE and their associated interlayer messages are coupled to the single coaxial cable baseband signal line. To achieve this basic objective, the MAU component contains the following functional capabilities to handle message flow between the DTE and the baseband medium:

- a) *Transmit function.* The ability to transmit serial data bit streams on the baseband medium from the local DTE entity to one or more remote DTE entities on the same network.
- b) *Receive function.* The ability to receive serial data bit streams over the baseband medium.
- c) *Collision Presence function.* The ability to detect the presence of two or more stations' concurrent transmissions.
- d) *Jabber function.* The ability to automatically interrupt the Transmit function and inhibit an abnormally long output data stream.

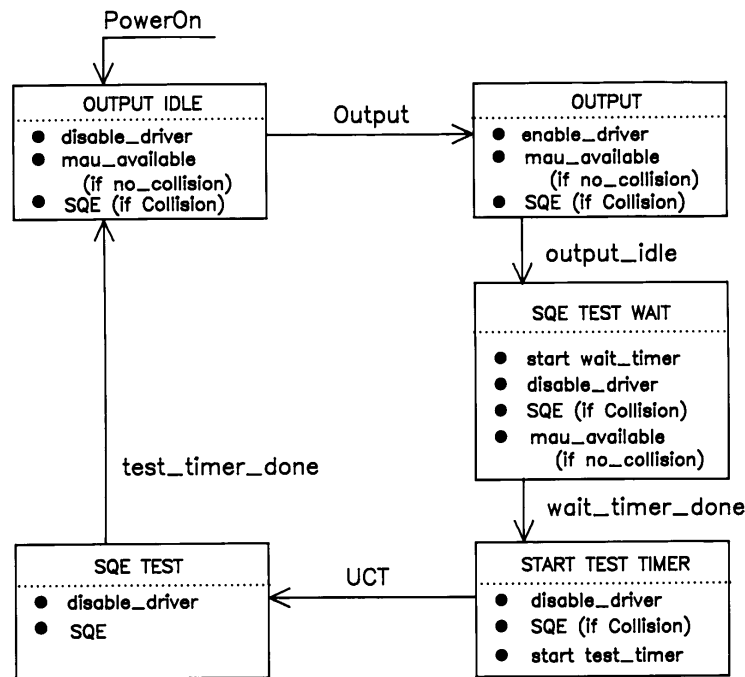
### 10.3.1 MAU Physical Layer functional requirements

#### 10.3.1.1 Transmit function requirements

At the start of a frame transmission on the coaxial cable, no more than 2 bits (2 full bit cells) of information may be received from the DO circuit and not transmitted onto the coaxial medium. In addition, it is permissible for the first bit sent to contain invalid data or timing; however, all successive bits of the frame shall be reproduced with no more than the specified amount of jitter. The 4th bit cell shall be carried from the DO signal line and transmitted onto the coaxial trunk cable medium with the correct timing and signal levels. The steady-state propagation delay between the DO circuit receiver input and the coaxial cable output shall not exceed 1/2 bit cell. There shall be no logical signal inversions between the branch cable DO circuit and the coaxial trunk cable (for example, a “high” logic level input to the MAU shall result in the less negative current flow value on the trunk coaxial medium). A positive signal on the A signal lead of the DO circuit shall result in a more positive voltage level on the trunk coaxial medium. It is assumed that the AUI shall provide adequate protection against noise. It is recommended that the designer provide an implementation in which a minimum threshold signal is required to establish a transmit bit stream.

The Transmit function shall output a signal on the trunk coaxial medium whose levels and waveform comply with 10.4.1.3.

In addition, when the DO circuit has gone idle after a frame is output, the MAU shall then activate the Collision Presence Function as close to the trunk coaxial cable as possible without introducing an extraneous signal on the trunk coaxial medium. The MAU shall initiate the Collision Presence state within 0.6  $\mu$ s to 1.6  $\mu$ s after the Output Idle signal (Wait\_Timer\_Done in Figure 10–2) and shall maintain an active Collision Presence state for a time equivalent to 10 bit cells  $\pm$  5 bit cells.



(UCT = unconditional transition)  
(Wait\_Timer\_Done is specified in 10.3.1.1)

Figure 10–2—MAU Interface function

### 10.3.1.2 Receive function requirements

The signal from the coaxial trunk cable shall be ac coupled before reaching the receive DI circuit. The Receive Function shall output a signal onto the DI circuit that complies with the specification for drivers in MAUs (7.5).

At the start of a frame reception from the coaxial cable, no more than 5 bits (5 full bit cells) of information may be received from the coaxial cable and not transmitted onto the receive DI circuit. In addition, it is permissible for the first bit sent over the receive circuit to contain invalid data or timing; however, all successive bits of the frame shall reproduce the incoming signal with no more than the amount of jitter specified below. This implies that the 7th bit cell presents valid data to the PLS. The steady-state propagation delay between the coaxial cable and the receive DI circuit output shall not exceed 1/2 bit cell. There are no logical signal inversions between the coaxial (trunk) cable and the MAU receive circuit.

A MAU meeting this specification shall exhibit edge jitter into the DI pair when terminated in the appropriate test load specified in 7.4.1.1, of no more than 7.0 ns in either direction when it is installed on the distant end of all lengths up to 185 m of the cable specified in 10.5.1.1 through 10.5.2.1.5 terminated at both ends with terminators meeting the impedance requirements of 10.6.2 and driven at one end with pseudorandom Manchester encoded binary data from a data generator that exhibits no more than 1.0 ns of edge jitter in either direction on half bit cells of exactly 1/2 BT and whose output meets the specifications of 10.4.1.3 except that the rise time of the signal shall be  $30 \text{ ns} + 0, - 2 \text{ ns}$ . The combination of coaxial cable and MAU receiver introduce no more than 6 ns of edge jitter into the system.

The local Transmit and Receive functions shall operate simultaneously while connected to the medium.

### 10.3.1.3 Collision Presence function requirements

The signal presented to the CI circuit in the absence of a collision shall be the IDL signal.

The signal presented to the CI circuit during the presence of a collision shall be the CS0 signal encoded as specified in 7.3.1.2. Under no conditions shall the Collision Presence function generate an output when only one MAU is transmitting. Table 10–1 summarizes the allowable conditions under which collisions shall be detected.

- a) Collision Assertion
  - 1) In the case where the MAU has been transmitting for at least 20 bit times, the CS0 signal shall be presented to the CI circuit no more than 17 bit times after the arrival at the MAU on the coaxial cable of a transmission from another MAU. Arrival at the MAU shall be considered to be the time when the transmission of the other MAU causes the dc level on the coaxial cable to become more negative.
  - 2) In all other cases where the MAU is transmitting, the CS0 signal shall be presented to the CI circuit no more than 29 bit times after the later of start of transmission by the MAU and the arrival of a transmission from another MAU.
- b) Collision De-assertion
  - 1) In the case where a collision has occurred between the MAU and one other MAU, the IDL signal shall be presented to the CI circuit no more than 17 bit times after either the end of transmission by the MAU or the arrival of the end of transmission from the other MAU, whichever occurs earlier. The arrival of the end of transmission from the other MAU shall be the time when the cessation of transmission causes the dc level on the coaxial cable to become less negative.
  - 2) In the case where a collision has occurred between more than two MAUs, the IDL signal shall be presented to the CI circuit no more than 29 bit times after the arrival of the end of transmission from all but one MAU.

These timing conditions shall be met for all data bit patterns and combinations of MDI, MAU transmit levels, and MAU locations on the segment.

The Collision Presence function may, in some implementations, be able to sense an abnormal (for example, open) medium.

**Table 10–1—Generation of collision presence signal**

MAU	Numbers of transmitters		
	<2	=2	>2
Transmitting	N	Y	Y
Not transmitting	N	Y	Y
Y = shall generate SQE message N = shall not generate SQE message			

#### 10.3.1.4 Jabber functional requirements

The MAU shall contain the capability as defined in Figure 10–3 to interrupt a transmission from a DO circuit that exceeds a time duration determined by the MAU. This time duration shall not be less than 20 ms nor more than 150 ms. If the frame being transmitted continues longer than the specified time duration, the MAU shall inhibit transmission and assume its not-transmitting state on the coaxial cable.

When the Transmit function has been positively disabled, the MAU shall then activate the Collision Presence function without introducing an extraneous signal on the trunk coaxial medium. A MAU may reset the Jabber and Collision Presence functions on power reset once the error condition has been cleared. Alternately, a MAU may reset these functions automatically after a period of 0.5 s ± 50%.

#### 10.3.2 MAU interface messages

##### 10.3.2.1 DTE to MAU messages

The following messages can be sent by the DTE Physical Layer (PLS Sublayer) Entities to the MAU Entities:

Message	Circuit	Signal	Meaning
<i>output</i>	DO	CD1, CD0	Output information
<i>output_IDL</i>	DO	IDL	No data to be output

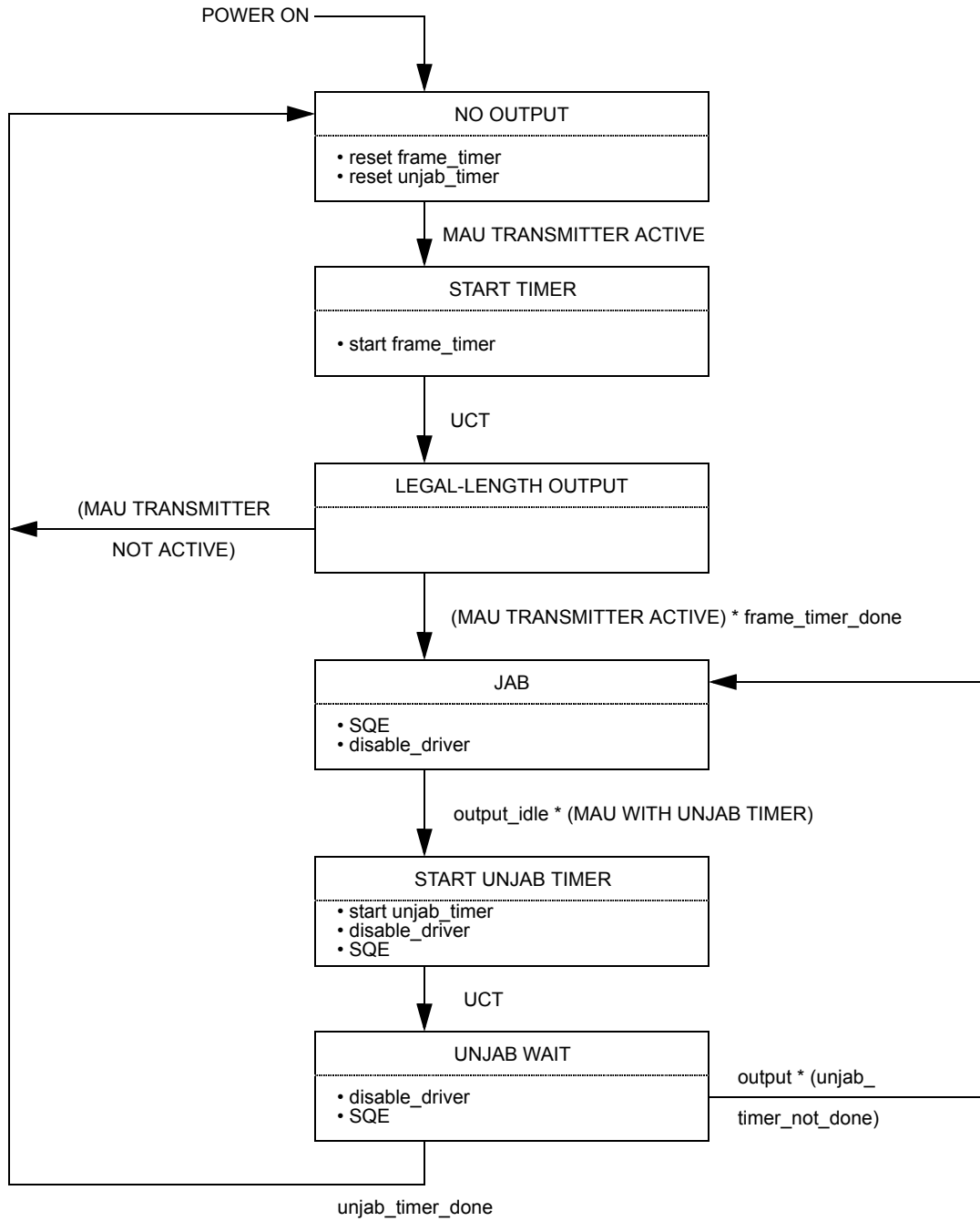
##### 10.3.2.2 MAU to DTE messages

The following messages can be sent by the MAU Physical Layer Entities to the DTE Physical Layer Entities:

Message	Circuit	Signal	Meaning
<i>input</i>	DI	CD1, CD0 <sup>a</sup>	Input information
<i>input_idle</i>	DI	IDL	No information to be input
<i>mau_available</i>	CI	IDL	MAU is available for output
<i>SQE</i>	CI	CS0	Error detected by MAU

<sup>a</sup>It is assumed that no retiming of these clocked data signals takes place within the MAU.





(Figure 10–3 outputs override those in Figure 10–2.  
Optional states: START UNJAB TIMER, UNJAB WAIT.)

**Figure 10–3—Jabber function state diagram**

#### 10.3.2.2.1 *input message*

The MAU sends an input message to the DTE Physical Layer when the MAU has a bit of data to send to the DTE. The physical realization of the input message is a CD0 or CD1 sent by the MAU to the DTE on the Data In circuit. The MAU sends CD0 if the input bit is a zero or CD1 if the input bit is a one. No retiming of the CD1 or CD0 signals takes place within the MAU.

#### 10.3.2.2.2 *input\_idle message*

The MAU sends an *input\_idle* message to the DTE Physical Layer when the MAU does not have data to send to the DTE. The physical realization of the *input\_idle* message is the IDL signal sent by the MAU to the DTE on the Data In circuit.

#### 10.3.2.2.3 *mau\_available message*

The MAU sends the *mau\_available* message to the DTE Physical Layer when the MAU is available for output. The *mau\_available* message is always sent by a MAU that is always prepared to output data unless the SQE message should be sent instead. Such a MAU does not require *mau\_request* to prepare itself for data output. The physical realization of the *mau\_available* message is an IDL signal sent by the MAU to the DTE on the Control In circuit.

#### 10.3.2.2.4 *signal\_quality\_error (SQE) message*

The SQE message shall be implemented in the following fashion:

- a) The SQE message shall not be sent by the MAU if no or only one MAU is transmitting on the trunk coaxial medium.
- b) If two or more remote MAUs are transmitting on the trunk coaxial medium, but the MAU connected to the local DTE is not transmitting, then the local MAU shall send the SQE message.
- c) When the local MAU is transmitting on the trunk coaxial medium, all occurrences of one or more additional MAUs transmitting shall cause the SQE to be sent by the local MAU to its DTE.
- d) When the MAU has completed each output frame it shall perform an SQE test sequence. Note that MAUs associated with repeaters shall not generate the SQE test sequence.
- e) When the MAU has inhibited the Transmit function, it shall send the SQE message in accordance with the Jabber function requirements of 10.3.1.4 and Figure 10–3.

The physical realization of the SQE message is the CS0 signal sent by the MAU to the DTE Physical Layers on the Control In circuit.

NOTE—The MAU is required to assert the SQE at the appropriate times whenever the MAU is powered and not just when the DTE Physical Layer is providing data output.

### 10.3.3 MAU state diagrams

The state diagrams, Figure 10–2 and Figure 10–3, depict the full set of allowed MAU state functions relative to the control circuits of the DTE-MAU interface for MAUs without conditioning requirements. Messages used in these state diagrams are explained as follows:

**enable\_driver.** Activates the path employed during normal operation to cause the MAU transmitter to impress data onto the trunk coaxial medium.

**disable\_driver.** Deactivates the path employed during normal operation to cause the MAU transmitter to impress data onto the trunk coaxial medium.

**no\_collision.** Signifies that the condition of multiple transmitters simultaneously active on the trunk coaxial medium does not exist.

**collision.** Signifies that the condition of multiple transmitters simultaneously active on the trunk coaxial medium does exist.

**frame\_timer.** Measures the time the MAU transmits on the trunk coaxial cable.

**test\_timer.** Measures the length of the SQE Test.

**unjab\_timer.** Measures the amount of time the MAU has been in Jab mode.

**wait\_timer.** Measures the time between output idle and the start of the SQE Test.

## 10.4 MAU–medium electrical characteristics

### 10.4.1 MAU-to-coaxial cable interface

The following subclauses describe the interface between the MAU and the coaxial cable. Negative current is defined as current into the MAU (out of the center conductor of the cable).

#### 10.4.1.1 Input impedance

The shunt capacitance presented to the coaxial cable by the MAU circuitry (not including the means of attachment to the coaxial cable) is recommended to be not greater than 6 pF. The magnitude of the reflection from a MAU plus the cable connection specified in 10.6.3 shall not be more than that produced by an 8 pF capacitance when measured by both a 25 ns rise time and 25 ns fall time waveform. The resistance presented to the coaxial cable shall be greater than 100 k $\Omega$ .

These conditions shall be met in both the power-off and power-on, not-transmitting states.

#### 10.4.1.2 Bias current

The MAU must draw (from the cable) between +2  $\mu$ A and –25  $\mu$ A in the power-off and the power-on, not-transmitting states.

#### 10.4.1.3 Coaxial cable signaling levels

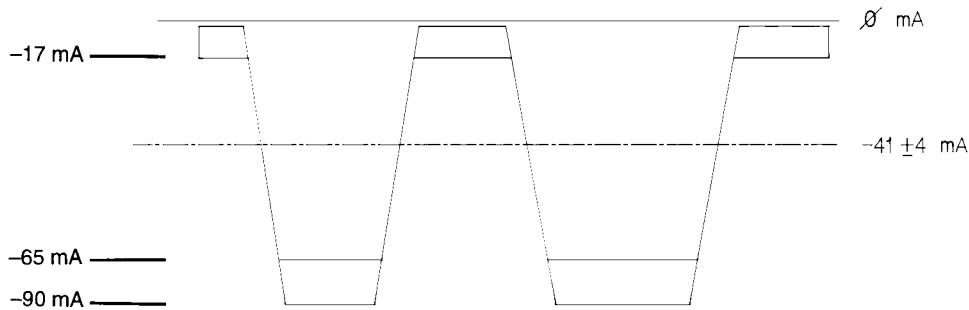
The signal on the coaxial cable due to a single MAU as measured at the MAU's transmitter output is composed of an ac component and an offset component. Expressed in terms of current immediately adjacent to the MAU connection (just prior to splitting the current flow in each direction), the signal has an offset component (average dc current including the effects of timing distortion) of from –37 mA min to –45 mA max and an ac component from  $\pm$  28 mA up to the offset value.

The current drive limit shall be met even in the presence of one other MAU transmitter. The MAU shall be capable of generating at least 2.2 V of average dc level on the coaxial cable in the presence of two or more other MAUs transmitting concurrently. The MAU shall, in addition, sink no more than  $\pm$  250  $\mu$ A when the voltage on the center conductor of the cable drops to –10 V when the MAU is transmitting.

The actual current measured at a given point on the cable is a function of the transmitted current and the cable loss to the point of measurement. Negative current is defined as current out of the center conductor of the cable (into the MAU). The 10 – 90% rise/fall times shall be 25 ns  $\pm$  5 ns at 10 Mb/s. The rise and fall times must match within 2 ns. Figure 10–4 shows typical waveforms present on the cable. Harmonic content generated from the 10 MHz fundamental periodic input shall meet the following requirements:

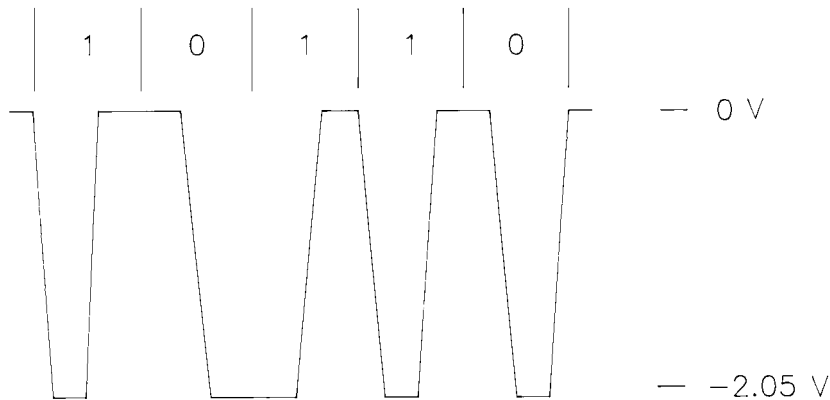
- Second and Third Harmonics: At least 20 dB below fundamental
- Fourth and Fifth Harmonics: At least 30 dB below fundamental
- Sixth and Seventh Harmonics: At least 40 dB below fundamental
- All Higher Harmonics: At least 50 dB below fundamental

NOTE—Even harmonics are typically much lower.



**Figure 10–4—Driver current signal levels**

The above specifications concerning harmonics cannot be satisfied by a square wave with a single-pole filter, nor can they be satisfied by an output waveform generator employing linear ramps without additional waveshaping. The signals, as generated from the encoder within PLS, shall appear on the coaxial cable without any inversions (see Figure 10–5).



- NOTE:** (1) Voltages given are nominal, for a single transmitter.  
 (2) Rise time is 25 ns nominal at 10 Mb/s rate.  
 (3) Voltages are measured on terminated coaxial cable adjacent to transmitting MAU.  
 (4) Manchester coding.

**Figure 10–5—Coaxial trunk cable signal waveform**

#### 10.4.1.4 Transmit output levels symmetry

Signals received from the DO circuit must be transmitted onto the coaxial cable with the characteristics specified in 10.4.1.3. Since the coaxial cable proceeds in two directions from the MAU, the current into the MAU is nominally twice the current measured on the coaxial cable.

The output signal of a MAU meeting this specification shall exhibit edge jitter of no more than 2.5 ns into a  $25\ \Omega \pm 1\%$  resistor substituted for the connection to the coaxial cable when the DO circuit into the MAU is driven with pseudo-random Manchester encoded binary data from a data generator that exhibits no more than 0.5 ns of edge jitter on half bit cells of exactly  $1/2$  BT, whose output meets the specifications of 7.4.1.1 through 7.4.1.5. The above specified component shall not introduce more than 2 ns of edge jitter into the system.

The MAU shall not transmit a negative going edge after cessation of the CD output data stream or before the first valid edge of the next frame.

#### 10.4.1.5 Collision detect thresholds

For receive mode collision detection the MAU shall have its collision detection threshold set in the range  $-1404$  mV and  $-1581$  mV. These limits take account of up to 8% collision detect filter impulse response. If a specific filter implementation has a higher value of impulse response, the lower threshold limit of  $-1404$  mV is required to be replaced by  $-1300\text{ mV} \times [1 + \text{impulse response}]$ .

Receive mode collision detection indicates that a nontransmitting MAU has the capability to detect collisions when two or more MAUs are transmitting simultaneously.

All MAUs are required to implement receive mode collision detection.

NOTE—The above threshold limits are measured at the coaxial cable center conductor with respect to the shield at the MAU connector. The MAU designer must take into account circuit offsets, low-frequency noise (for example, 50 Hz, 60 Hz), and 5 MHz ripple at the filter output in determining the actual internal threshold value and its tolerance.

### 10.4.2 MAU electrical characteristics

#### 10.4.2.1 Electrical isolation

The MAU must provide isolation between the DTE Physical Layer circuits and the coaxial trunk cable. The isolation impedance measured between any conductor in the DTE Physical Layer circuitry and either the center conductor or shield of the coaxial cable shall be greater than  $250\text{ k}\Omega$  at 50 Hz, 60 Hz. In addition, the isolation impedance between the DTE ground and the coaxial cable shield shall be less than  $15\ \Omega$  between 3 MHz and 30 MHz. The isolation means provided shall withstand 500 V ac, rms for one minute.

#### 10.4.2.2 Power consumption

The current drawn by the MAU shall not exceed 0.5 A if powered by the AUI source. The MAU shall be capable of operating from all permissible voltage sources as supplied by the DTE through the resistance of all permissible AUI cables. The MAU shall not disrupt the trunk coaxial medium should the DTE power source fall below the minimum operational level under abnormal MAU load conditions.

The MAU shall be labeled externally to identify the maximum value of current required by the device. This requirement only applies to MAUs that are external to DTEs.

### **10.4.2.3 Reliability**

The MAU shall be designed to provide an MTBF of at least 100 000 hours of continuous operation without causing communication failure among other stations attached to the local network medium. Component failures within the MAU electronics should not impede the communication among other MAUs on the coaxial cable. Connectors and other passive components comprising the means of connecting the MAU to the coaxial cable shall be designed to minimize the probability of total network failure.

It should be noted that a fault condition that causes a MAU to draw in excess of 2 mA from the coaxial cable may cause communication failure among other stations.

### **10.4.3 MAU–DTE electrical characteristics**

If the AUI is exposed, the electrical characteristics for the driver and receiver components connected between the DTE Physical Layer circuitry and the MAU shall be identical with those as specified in Clause 7 of this standard.

## **10.5 Characteristics of coaxial cable system**

The trunk cable is of constant impedance, coaxial construction. It is terminated at each of the two ends by a terminator (see 10.6.2), and provides the transmission path for connection of MAU devices. Coaxial cable connectors are used to make the connection from the cable to the terminators and between cable sections. The cable has various electrical and mechanical requirements that shall be met to ensure proper operation.

### **10.5.1 Coaxial cable electrical parameters**

The parameters specified in 10.5.1 are met by cable types RG 58 A/U or RG 58 C/U.

#### **10.5.1.1 Characteristic impedance**

The average characteristic cable impedance shall be  $50 \pm 2 \Omega$ . Periodic variations in impedance along a single piece of cable may be up to  $\pm 3 \Omega$  sinusoidal, centered around the average value, with a period of less than 2 m.

#### **10.5.1.2 Attenuation**

The attenuation of a 185 m cable segment shall not exceed 8.5 dB measured at 10 MHz, or 6.0 dB measured at 5 MHz.

#### **10.5.1.3 Velocity of propagation**

The minimum required velocity of propagation is 0.65 c.

#### **10.5.1.4 Edge jitter; entire segment without DTEs attached**

A coaxial cable segment meeting this specification shall exhibit edge jitter of no more than 8.0 ns in either direction at the receiving end when 185 m of the cable is terminated at both ends with terminators meeting the impedance requirements of 10.6.2 and is driven at one end with pseudorandom Manchester encoded binary data from a data generator that exhibits no more than 1.0 ns of edge jitter in either direction on half bit cells of exactly  $1/2$  BT and whose output meets the specifications of 10.4.1.3, except that the rise time of the signal must be  $30 \text{ ns} + 0, - 2 \text{ ns}$ , and no offset component in the output current is required. This test shall be conducted in a noise-free environment. The above specified component is not to introduce more than 7 ns of edge jitter into the system.

### 10.5.1.5 Transfer impedance

The coaxial cable medium shall provide sufficient shielding capability to minimize its susceptibility to external noise and also to minimize the generation of interference by the medium and related signals. While the cable construction is not mandated, it is necessary to indicate a measure of performance expected from the cable component. A cable's EMC performance is determined, to a large extent, by the transfer impedance value of the cable.

The transfer impedance of the cable shall not exceed the values shown in Figure 10–6 as a function of frequency.

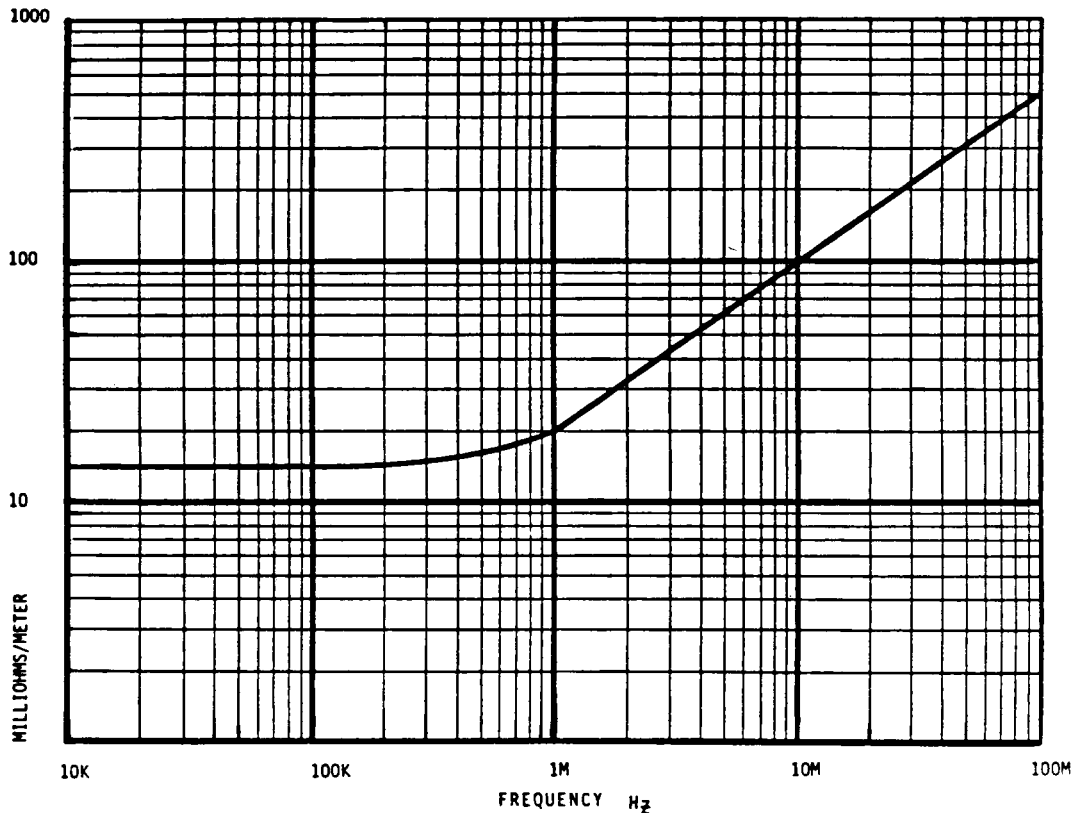


Figure 10–6—Maximum coaxial cable transfer impedance

### 10.5.1.6 Cable dc loop resistance

The sum of the center conductor resistance plus the shield resistance measured at 20 °C shall not exceed 50 mΩ/m.

## 10.5.2 Coaxial cable physical parameters

### 10.5.2.1 Mechanical requirements

The cable used should be suitable for routing in various environments, including but not limited to, dropped ceilings, raised floors, and cable troughs as well as throughout open floor space. The jacket shall provide insulation between the cable sheath and any building structural metal. Also, the cable shall be capable of accepting coaxial cable connectors, described in 10.6. The cable shall conform to the following requirements.

#### **10.5.2.1.1 General construction**

- a) The coaxial cable shall consist of a center conductor, dielectric, shield system, and overall insulating jacket.
- b) The coaxial cable shall be sufficiently flexible to support a bend radius of 5 cm.

#### **10.5.2.1.2 Center conductor**

The center conductor shall be stranded, tinned copper with an overall diameter of  $0.89 \text{ mm} \pm 0.05 \text{ mm}$ .

#### **10.5.2.1.3 Dielectric material**

The dielectric may be of any type, provided that the conditions of 10.5.1.2 and 10.5.1.3 are met; however, a solid dielectric is preferred.

#### **10.5.2.1.4 Shielding system**

The shielding system may contain both braid and foil elements sufficient to meet the transfer impedance of 10.5.1.5 and the EMC specifications of 10.8.2.

The inside diameter of the shielding system shall be  $2.95 \text{ mm} \pm 0.15 \text{ mm}$ .

The shielding system shall be greater than 95% coverage. The use of tinned copper braid is recommended to meet the contact resistance and shielding requirements.

#### **10.5.2.1.5 Overall jacket**

- a) Any one of several jacket materials shall be used provided the specifications of 10.5.1 and 10.5.2 are met.
- b) Either of two jacket dimensions may be used for the two broad classes of materials provided the specification of 10.5.2.1.1 are met:
  - 1) Polyvinyl chloride (for example, PVC) or equivalent having an OD of  $4.9 \text{ mm} \pm 0.3 \text{ mm}$ .
  - 2) Fluoropolymer (for example, FEP, ECTFE) or equivalent having an OD of  $4.8 \text{ mm} \pm 0.3 \text{ mm}$ .

The cable shall meet applicable flammability and smoke criteria to meet the local and national codes for the installed environment (see 10.8.3).

Different types of cable sections (for example, polyvinyl chloride and fluoropolymer dielectric) may be interconnected, while meeting the sectioning requirements of 10.7.2.1.

#### **10.5.2.2 Jacket marking**

It is recommended that the cable jacket be marked with manufacturer and type at a nominal frequency of at least once per meter along the cable.

#### **10.5.3 Total segment dc loop resistance**

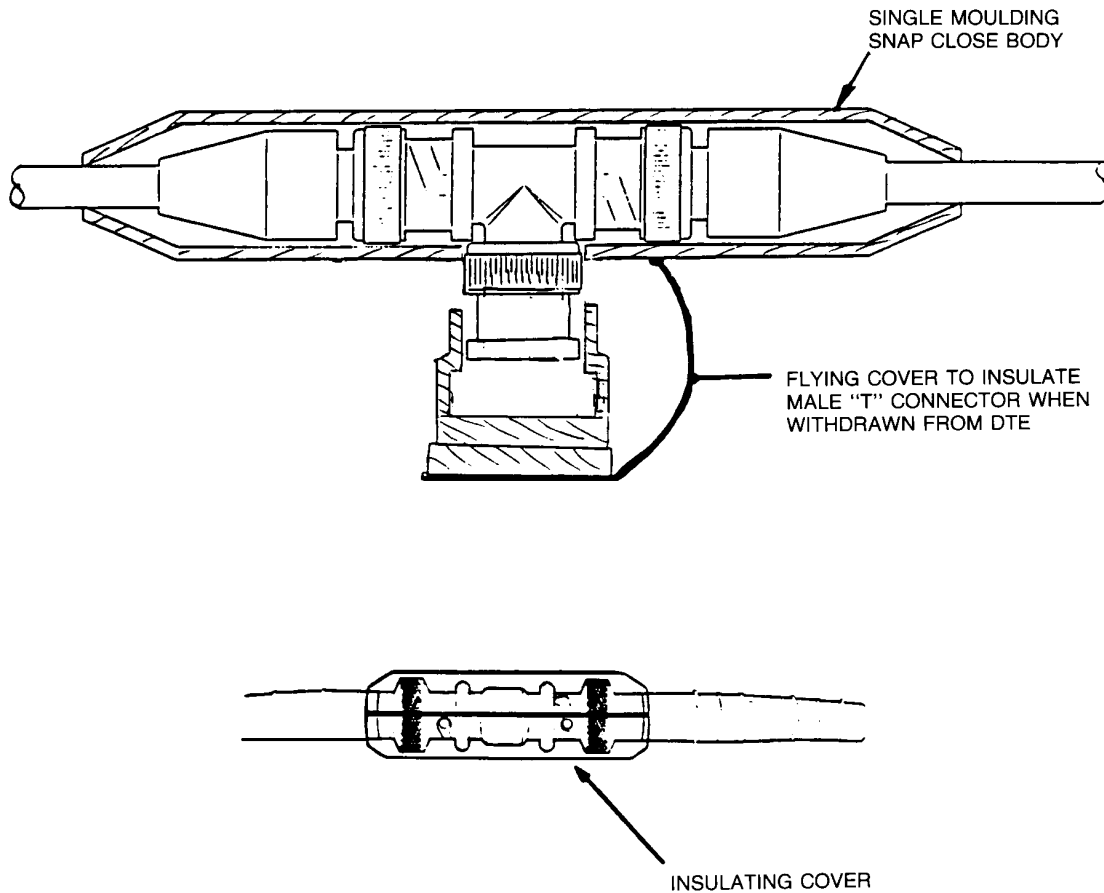
The sum of the center conductor, connectors, and shield resistance shall not exceed  $10 \Omega$  total per segment. Each in-line connector pair or MAU shall contribute no more than  $10 \text{ m}\Omega$ .

As a trunk coaxial cable segment consists of several cable sections, all connectors and internal resistance of the shield and center conductor shall be included in the loop resistance measurement.



## 10.6 Coaxial trunk cable connectors

The trunk coaxial medium requires termination and is partitioned into sections. Devices to be attached to the medium require a means of connection to the medium. This means is provided by a BNC “T” adapter, as shown in Figure 10–7.



(Tutorial only and not part of the standard.)

**Figure 10–7—Examples of insulated connector cover**

The BNC connectors shall be of the 50  $\Omega$  constant impedance type. High-quality versions of these connectors (per IEC 169-8) are recommended in order to meet dc loop resistance and reliability considerations. All of the coaxial connectors shall follow the requirements as defined in 10.6.3.

### 10.6.1 In-line coaxial extension connector

All coaxial cables shall be terminated with BNC plug connectors. A means shall be provided to ensure that the connector shell (which connects to the cable sheath) does not make contact with any building metal (at ground potential) or other unintended conductor.

An insulating sleeve or boot slipped over the connector at installation time is suitable.

In-line coaxial extensions shall be made with BNC receptacle-to-receptacle connectors joined together to form one “barrel.” An insulating sleeve or boot shall also be provided with each barrel assembly.

### 10.6.2 Coaxial cable terminator

Coaxial cable terminators are used to provide a termination impedance for the cable equal in value to its characteristic impedance, thereby minimizing reflection from the ends of the cables. Terminators shall be packaged within a male or female connector. The termination impedance shall be  $50 \Omega \pm 1\%$  measured from 0 MHz to 20 MHz, with the magnitude of the phase angle of the impedance not to exceed  $5^\circ$ . The terminator power rating shall be 0.5 W or greater. A means of insulation shall be provided with each terminator.

### 10.6.3 MAU-to-coaxial cable connection

A BNC “T” (plug, receptacle, plug) adaptor provides a means of attaching a MAU to the coaxial cable. The connection shall not disturb the transmission line characteristics of the cable significantly; it shall present a low shunt capacitance, and therefore a negligibly short stub length. This is facilitated by the MAU being located as close to its cable connection as possible; the MAU and connector are normally considered to be one assembly. Long (greater than 4 cm) connections between the coaxial cable and the input of the MAU jeopardize this objective.

Overall system performance is dependent largely on the MAU-to-coaxial cable connection being of low shunt capacitance.

The design of the connection shall meet the electrical requirements contained in 10.4.1.1 and the reliability specified in 10.4.2.3. The use of BNC “T” adaptors and connectors satisfies these requirements. Figure 10–7 shows a MAU-to-coaxial cable attachment.

A means shall be provided to ensure that the connector assembly (that is, BNC “T” plus male connectors) does not make contact with any building metalwork (at ground potential) or any other unintended conductors. An insulating cover should therefore be applied after connection. A possible design is depicted in Figure 10–7. The insulating cover should have these characteristics:

- a) It should guard against accidental grounding of the connector assembly.
- b) It should allow ease of attachment and detachment of an assembled “T” connector to the MAU without necessitating the removal of section cable connectors (that is, segment integrity is maintained).
- c) It should be a simple moulding that attaches firmly to a connector assembly.

## 10.7 System considerations

### 10.7.1 Transmission system model

The maximum configuration for the physical transmission system is as follows:

- a) A trunk coaxial cable, terminated in its characteristic impedance at each end, constitutes a coaxial cable segment. A coaxial cable segment may contain a maximum of 185 m of coaxial cable and a maximum of 30 MAUs. The propagation velocity of the coaxial cable is assumed to be 0.65 c minimum ( $c = 3 \times 10^8$  m/s). The maximum end-to-end propagation delay for a coaxial cable segment is 950 ns.
- b) The maximum transmission path permitted between any two MAUs is limited by the number of repeater sets that can be connected in series.

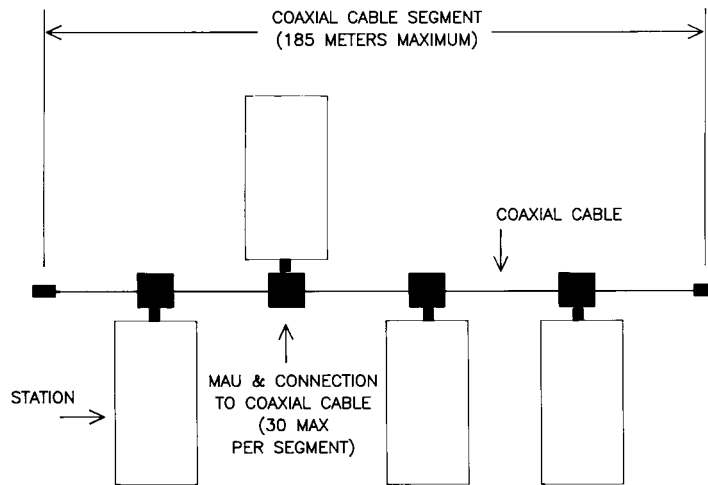
NOTE—Care should be taken to ensure that the safety requirements are met when extending the trunk cable by the use of repeaters (see 10.7.2.4.1).

- c) The repeater unit specified in Clause 9 provides the means for connecting 10 Mb/s baseband segments into a CSMA/CD network. The proper operation of a CSMA/CD network requires network

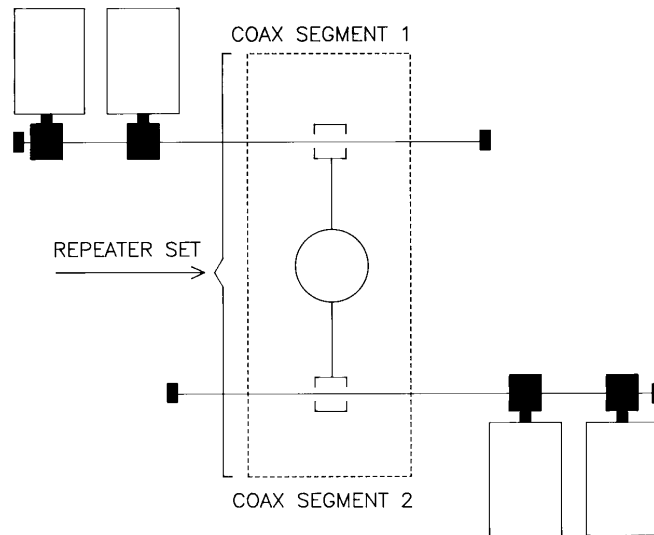
size to be limited to control round-trip propagation delay to meet the requirements of 4.2.3.2.3 and 4.4.2, and the number of repeaters between any two DTEs to be limited in order to limit the shrinkage of the interpacket gap as it travels through the network. Configuration rules, which ensure that these limits are not exceeded, are given in Clause 13.

NOTE—Care should be taken to ensure that the safety requirements are met when extending the trunk cable by the use of repeaters (see 10.7.2.4.1)

Figure 10–8 and Figure 10–9 show minimal single segment and repeatered transmission systems. For specifications on the boundary conditions on topologies, see Clause 13.



**Figure 10–8—The minimum system configuration**



**Figure 10–9—The minimum system configuration requiring a repeater set**

## 10.7.2 Transmission system requirements

### 10.7.2.1 Cable sectioning

The 185 m maximum length coaxial cable segment will be made from a number of cable sections. As the variation on cable characteristic impedance is  $\pm 2 \Omega$  on  $50 \Omega$ , a possible worst-case reflection of 4% may result from the mismatch between two adjacent cable sections. The MAU will add to this reflection by the introduction of its noninfinite bridging impedance.

The accumulation of this reflection can be minimized by observing a minimum distance between MAUs (and between cable sections). In order to maintain reflections at an acceptable level, the minimum length cable section shall be 0.5 m.

### 10.7.2.2 MAU placement

MAU components and their associated connections to the cable cause signal reflections due to their noninfinite bridging impedance. While this impedance must be implemented as specified in 10.6, the placement of MAUs along the coaxial cable must also be controlled to ensure that reflections from the MAU do not accumulate to a significant degree.

Coaxial cable sections as specified in 10.7.2.1 shall be used to connect MAUs. This guarantees a minimum spacing between MAUs of 0.5 m.

The total number of MAUs on a cable segment shall not exceed 30.

### 10.7.2.3 Trunk cable system earthing

The shield conductor of each coaxial cable segment may make electrical contact with an effective earth reference<sup>28</sup> at one point and shall not make electrical contact with earth elsewhere on such objects as building structural metal, ducting, plumbing fixture, or other unintended conductor. Insulators should be used to cover any coaxial connectors used to join cable sections and terminators, to ensure that this requirement is met. A sleeve or boot attached at installation time is acceptable. (See 10.6.3.)

### 10.7.2.4 Static discharge path

A static discharge path shall be provided. The shield of the trunk coaxial cable is required to be connected to each DTE earth (within the DTE) via a  $1 \text{ M}\Omega$ , 0.25 W resistor that has a voltage rating of at least 750 V dc.

#### 10.7.2.4.1 Installation environment

This specification is intended for networks in use within a single building and within an area served by a single low-voltage power distribution system. Applications requiring interplant connections via external (outdoors) means may require special considerations. Repeaters and nonconducting IRL components may provide the means to satisfy these isolation requirements.

NOTE—The reader is advised that devices should not be operated at significantly different frame potentials. The 10BASE2 connection system may not be capable of handling excessive earth currents.

---

<sup>28</sup>See local or national regulations for guidance on these matters and reference [B49].

## 10.8 Environmental specifications

### 10.8.1 Safety requirements

The designer should consult relevant local and national safety regulations to assure compliance with the appropriate standards (for example, see Annex A for reference material).

#### 10.8.1.1 Installations

If the trunk coaxial cable is to be installed in close proximity to electrical power cables, then installation practice according to local and national code shall be followed (see Annex A for resource material).

#### 10.8.1.2 Earthing

Where earthing is mandated by locally or nationally prescribed codes of practice, the shield of the trunk coaxial cable shall be effectively earthed at only one point along the length of the cable. Effectively earthed means permanently connected to earth through an earth connection of sufficiently low impedance and having sufficient ampacity to prevent the building up of voltages that may result in undue hazard to connected equipment or to persons.

### 10.8.2 Electromagnetic environment

#### 10.8.2.1 Susceptibility levels

Sources of interference from the environment include electromagnetic fields, electrostatic discharge, transient voltages between earth connections, etc.

Several sources of interference will contribute to voltage buildup between the coaxial cable and the earth connection of a DTE.

The physical channel hardware shall meet its specifications when operating in either of the following conditions:

- a) Ambient plane wave field of 1 V/m from 10 kHz through 1 GHz.  
NOTE—Levels typically >1 km from broadcast stations.
- b) Interference source voltage of 15.10 V peak 10 MHz sine wave with a 50  $\Omega$  source resistance applied between the coaxial cable shield and the DTE ground connection.

MAUs meeting this standard should provide adequate RF ground return (coaxial cable shield to DTE ground) to satisfy the referenced EMC specifications.

#### 10.8.2.2 Emission levels

The physical MAU and trunk cable system shall comply with local and national regulations (see Annex A for resource material).

### 10.8.3 Regulatory requirements

The MAU and medium should consider IEC 60950 in addition to local and national regulations. See IEC 60950 and [B49].



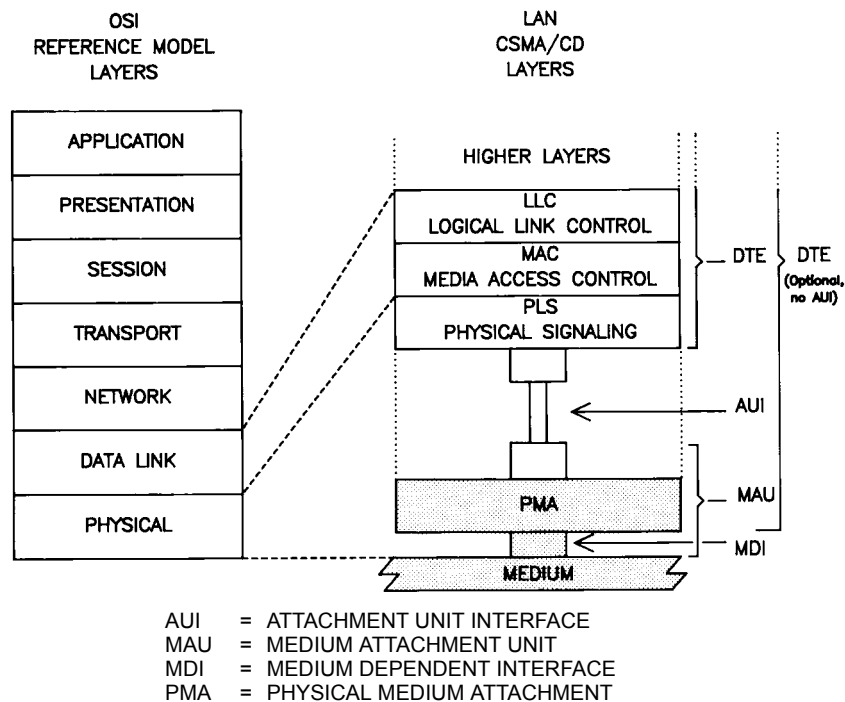
## 11. Broadband medium attachment unit and broadband medium specifications, type 10BROAD36

NOTE—This MAU is not recommended for new installations. Since September 2003, maintenance changes are no longer being considered for this clause.

### 11.1 Scope

#### 11.1.1 Overview

This clause defines the functional, electrical, and mechanical characteristics of the Broadband Medium Attachment Unit (MAU) and the specific single- and dual-cable broadband media for use with LANs. The headend frequency translator for single-cable broadband systems is also defined. The relationship of this clause to all of the ISO/IEC LAN International Standards is shown in Figure 11–1. Repeaters as defined in Clause 9 are not relevant for 10BROAD36.

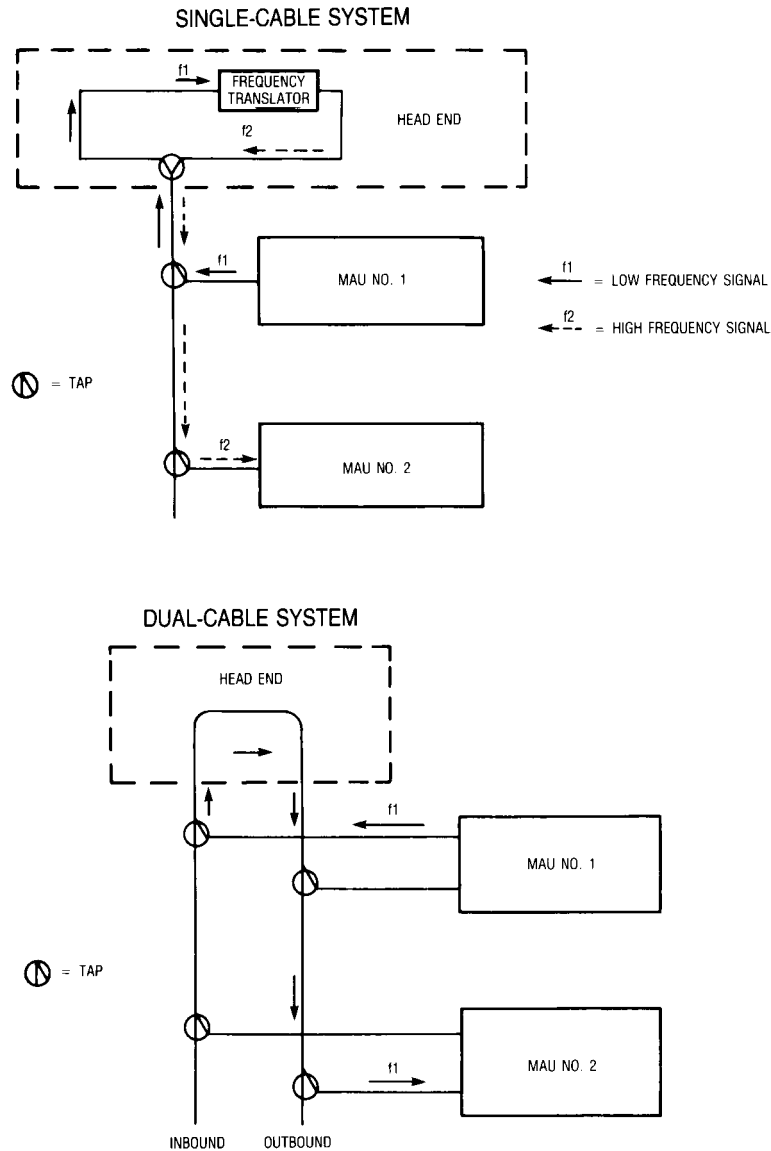


**Figure 11–1—Physical Layer partitioning, relationship to the ISO/IEC Open Systems Interconnection (OSI) reference model**

The purpose of the MAU is to provide a means of attaching devices to a broadband local network medium. The medium comprises CATV-type cable, taps, connectors, and amplifiers. A coaxial broadband system permits the assignment of different frequency bands to multiple applications. For example, a band in the spectrum can be utilized by LANs while other bands are used by point-to-point or multidrop links, television, or audio signals.

The physical tap is a passive directional device such that the MAU transmission is directed toward the head-end location (reverse direction). On a single-cable system the transmission from the MAU is at a carrier fre-

quency  $f_1$ . A frequency translator (or remodulator) located at the headend up-converts to a carrier frequency  $f_2$ , which is sent in the forward direction to the taps (receiver inputs). On a dual-cable system the transmit and receive carrier frequencies are identical (both  $f_1$ ) and the MAU connects to the medium via two taps, one on the receive cable and the other on the transmit cable. The transmit and receive cables are connected to each other at the headend location. Figure 11–2 shows broadband single- and dual-cable systems.



**Figure 11–2—Broadband cable systems**

The broadband MAU operates by accepting data from the attached Data Termination Equipment (DTE) and transmitting a modulated radio frequency (RF) data signal in a data band on the broadband coaxial cable system. All MAUs attached to the cable system receive and demodulate this RF signal and recover the DTE data. The broadband MAU emulates a baseband MAU except for delay between transmission and reception, which is inherent in the broadband cable system.



A transmitting MAU logically compares the beginning of the received data with the data transmitted. Any difference between them, which may be due to errors caused by colliding transmissions, or reception of an earlier transmission from another MAU, or a bit error on the channel, is interpreted as a collision.

When a collision is recognized, the MAU stops transmission in the data band and begins transmission of an RF collision enforcement (CE) signal in a separate CE band adjacent to the data band. The CE signal is detected by all MAUs and informs them that a collision has occurred. All MAUs signal to their attached Medium Access Controllers (MACs) the presence of the collision. The transmitting MACs then begin the collision handling process.

Collision enforcement is necessary because RF data signals from different MAUs on the broadband cable system may be received at different power levels. During a collision between RF data signals at different levels, the MAU with the higher received power level may see no errors in the detected data stream. However, the MAU with the lower RF signal will see a difference between transmitted and received data; this MAU transmits the CE signal to force recognition of the collision by all transmitting MAUs.

### 11.1.2 Definitions

See 1.4.

### 11.1.3 MAU and medium objectives

This subclause states the broad objectives and assumptions underlying the specifications defined throughout this clause of the standard.

- a) Provide the physical means for communication among local network Data Link Entities using a broadband coaxial medium.
- b) Provide a broadband Medium Attachment Unit (MAU) that is compatible at the Attachment Unit Interface (AUI) with DTEs used on a baseband medium.
- c) Provide a broadband MAU that emulates the baseband MAU except for the signal delay from Circuit DO to Circuit DI.
- d) Provide a broadband MAU that detects collisions within the timing constraints specified in the baseband case.
- e) Provide a broadband network diameter no less than 2800 m.
- f) Provide a broadband Physical Layer that ensures that no MAU is allowed to capture the medium during a collision due to signal level advantage (that is, ensures fairness of the physical layer).
- g) Provide a broadband MAU that detects collisions in both receive and transmit modes.
- h) Provide a broadband MAU that requires a transmission bandwidth no wider than 18 MHz.
- i) Define a physical interface that can be implemented independently among different manufacturers of hardware and achieve the intended level of compatibility when interconnected in a common broadband LAN.
- j) Provide a communication channel capable of high bandwidth and low bit error ratio performance. The resultant mean bit error ratio at the physical layer service interface should be less than one part in  $10^8$  (on the order of one part in  $10^9$  at the link level) in a worst-case signal-to-noise ratio of 26 dB.
- k) Provide a broadband medium physical layer that allows for implementation in both dual- and single-cable systems.
- l) Provide for ease of installation and service.
- m) Provide a communication channel that coexists with other channels on the same physical medium.

It is not an objective of this broadband MAU to allow its use with the baseband repeater defined in Clause 9 of this standard.

#### 11.1.4 Compatibility considerations

All implementations of the broadband coaxial system shall be compatible at the Medium Dependent Interface (MDI). This standard provides medium specifications for the interconnection of all MAU devices. The medium itself, the functional capability of the MAU and the AU Interface are defined to provide the highest possible level of compatibility among devices designed by different manufacturers. Designers are free to implement circuitry within the MAU in an application-dependent manner provided the MDI and AUI specifications are satisfied. Subsystems based on this specification may be implemented in several different ways provided compatibility at the medium is maintained. It is possible, for example, to design an integrated station where the MAU is contained within a physical DTE system component, thereby eliminating the AUI cable.

#### 11.1.5 Relationship to PLS and AUI

The broadband MAU and cable system specifications are closely related to Clause 7 (Physical Signaling and Attachment Unit Interface Specifications). The design of a physical MAU component requires the use of both this clause and the PLS and AUI specifications in Clause 7.

#### 11.1.6 Mode of operation

In its normal mode of operation, the MAU functions as a direct connection between the DTE and the broadband medium. Data from the DTE are transmitted onto the broadband coaxial system and all inband data on the coaxial cable system is received by the DTE. This mode is the mode of operation for the intended message traffic between stations. Other operating modes, such as a loopback mode or a monitor mode, may be provided but are not defined by this standard.

### 11.2 MAU functional specifications

#### 11.2.1 MAU functional requirements

The MAU component provides the means by which signals on the physically separate AUI signal circuits to and from the DTE and their associated interlayer messages are coupled to the broadband coaxial medium. To achieve this basic objective, the MAU component contains the following capabilities to handle message flow between the DTE and the broadband medium:

- a) *Transmit function.* The ability to transmit serial data bit streams originating at the local DTE in a band-limited modulated RF carrier form, to one or more remote DTEs on the same network.
- b) *Receive function.* The ability to receive a modulated RF data signal in the band of interest from the broadband coaxial medium and demodulate it into a serial bit stream.
- c) *Collision Presence function.* The ability to detect the presence of two or more stations' concurrent transmissions.
- d) *Jabber function.* The ability of the MAU itself to interrupt the Transmit function and inhibit an abnormally long output data stream.

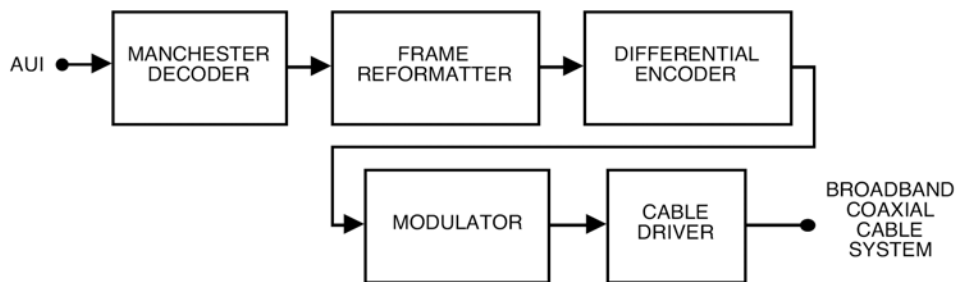
##### 11.2.1.1 Transmit function requirements

The Transmit function shall include the following capabilities:

- a) Receive Manchester encoded data sent by the local DTE to the attached MAU on Circuit DO (transmit data pair).
- b) Decode the Manchester encoded data received on Circuit DO to produce NRZ (Non-Return to Zero) data and a recovered clock signal.

- c) Scramble the NRZ data using a CCITT V.29-type scrambler with seed changed on each transmitted packet.
- d) Transform the incoming bits (prior to modulation) to provide an unscrambled alternating zero-one pattern terminated by an Unscrambled Mode Delimiter (UMD); scramble the remainder of the incoming preamble, Start Frame Delimiter (SFD), and data frame; and append an unscrambled postamble (Broadband End of Frame Delimiter [BEOFD]).
- e) Differentially encode the packet generated above.
- f) Produce a bandlimited, double sideband suppressed carrier, binary PSK modulated RF signal representing the above generated differentially encoded packet.
- g) Drive the coaxial cable with the modulated RF signal.

Figure 11–3 functionally represents these capabilities. The order of the functional blocks may be altered provided that the result is the same.



**Figure 11–3—Transmit function requirements**

### 11.2.1.2 Receive function requirements

The receive function shall include the following:

- a) Receive the differentially encoded binary PSK modulated RF signal from the broadband coaxial medium.
- b) Receive the data band RF signals and reject signals in bands other than the data band (rejection of signals in the adjacent collision enforcement band is optional).
- c) Demodulate and differentially decode the incoming RF data signal from the coaxial medium to provide a receive bit stream that represents the scrambled bit stream at the transmitter.
- d) Descramble the receive bit stream using a self-synchronizing descrambler.
- e) Manchester encode the descrambled bit stream.
- f) Send to the DTE, using Circuit DI (receive data pair), an additional, locally-generated, Manchester encoded preamble equal to the number of preamble bits lost in the receive data path (plus or minus one bit), followed by the Manchester encoded bit stream. No more than 6 preamble bits may be lost from the preamble presented to Circuit DO at the transmitting MAU.
- g) Detect end of frame, using the postamble (BEOFD), and ensure that no extraneous bits are sent to the DTE on Circuit DI.
- h) Receive signals in the collision enforcement band and reject signals in the data band and all other bands on the broadband medium.

### 11.2.1.3 Collision Detection function requirements

The MAU shall perform the following functions to meet the collision detection requirements:

- a) Store the scrambled bits (not differentially encoded) in the transmit section through to the last bit in the source address.

- b) Detect the UMD in the transmit and receive paths.
- c) Compare received scrambled bits after the received UMD with transmitted scrambled bits after the transmit UMD through to the last bit in the source address.
- d) A Receive UMD Timer function shall be performed by the MAU. The timer shall be as long as the time required from initial detection of RF data signal presence to detection of a UMD in a normally received (no collision) packet.
- e) Enter a LOCAL COLLISION DETECTION state if one of the following occurs:
  - 1) A bit error is found in the bit compare process through the last bit in the source address.
  - 2) The Receive UMD Timer expires before a UMD is detected in the received bit stream.
  - 3) The MAU receives the *output* (that is, transmit) signal from the AUI AFTER having received an RF signal from the coaxial cable.
- f) Upon entering the LOCAL COLLISION DET state, cease transmission in the data band and commence transmission in the collision enforcement band for as long as the DTE continues to send data to the MAU.
- g) Upon entering the LOCAL COLLISION DET state send the *signal\_quality\_error* (SQE) message on Circuit CI (collision presence pair) using the CS0 signal for as long as RF signals are detected on the broadband coaxial medium in either the data or collision enforcement bands.
- h) Detect power in the collision enforcement band and send the SQE message on Circuit CI using the CS0 signal. Send the SQE message for as long as energy is detected in the collision enforcement band.
- i) Ensure that during collisions, due to phase cancellations of the colliding carriers, Circuit DI does not become inactive before Circuit CI becomes active.
- j) Test the collision detection circuitry following every transmission that does not encounter a collision. This test consists of transmitting a burst of collision enforcement RF signal after the end of the postamble transmission and detecting this burst on the receive side. If the burst is detected, the CS0 (BR) signal is sent on Circuit CI of the transmitting MAU.

#### 11.2.1.3.1 Collision enforcement transmitter requirements

The MAU shall provide a collision enforcement (CE) transmitter that generates a constant amplitude RF signal in the CE band at the same power level as the data signal postamble.

#### 11.2.1.3.2 Collision enforcement detection requirements

The MAU shall detect energy in the CE band that is within the specified range of receive levels, irrespective of the signal power level in the data band.

#### 11.2.1.4 Jabber function requirements

The MAU shall have a Jabber function that inhibits transmission onto the coaxial cable interface if the MAU attempts to transmit an RF signal longer than 150 ms. The MAU shall provide an MTBF of at least 1 million hours of continuous operation without rendering the transmission medium unusable by other transceivers. Transmissions of less than 20 ms shall not be affected. When the jabber circuit is activated, *signal\_quality\_error* shall be sent on Circuit CI.

Circuit DO shall also be monitored for transmissions in excess of the maximum packet length. If the packet is longer than 20 ms, an attempt shall be made to deactivate the transmitter before the jabber circuit is activated, to avoid locking up the unit due to a non-MAU failure.

State diagrams defining the Jabber function may be found in 11.2.3.

## 11.2.2 DTE PLS to MAU and MAU to DTE PLS messages

### 11.2.2.1 DTE Physical Layer to MAU Physical Layer messages

The following messages can be sent by the DTE Physical Layer entities to the MAU Physical Layer entities (refer to 7.3 of this standard for the definitions of the signals):

Message	Circuit	Signal	Meaning
<i>output</i>	DO	CD1, CD0	Output information
<i>output_idle</i>	DO	IDL	No data to be output

### 11.2.2.2 MAU Physical Layer to DTE Physical Layer messages

The following messages can be sent by the MAU Physical Layer entities to the DTE Physical Layer entities:

Message	Circuit	Signal	Meaning
<i>input</i>	DI	CD1, CD0	Input information
<i>input_idle</i>	DI	IDL	No input information
<i>mau_available</i>	CI	IDL	MAU is available for output
<i>signal_quality_error</i>	CI	CS0 (BR)	Error detected by MAU

#### 11.2.2.2.1 *input* message

The MAU Physical Layer sends an *input* message to the DTE Physical Layer when the MAU has a bit of data to send to the DTE. The physical realization of the *input* message is a CD0 or CD1 sent by the MAU to the DTE on Circuit DI. The MAU sends CD0 if the input bit is a zero or CD1 if the input bit is a one. The jitter and asymmetry on CD0 and CD1 shall be no more than that specified in 7.5.2.1.

#### 11.2.2.2.2 *input\_idle* message

The MAU Physical Layer sends an *input\_idle* message to the DTE Physical Layer when the MAU does not have data to send to the DTE. The physical realization of the *input\_idle* message is the IDL signal sent by the MAU to the DTE on Circuit DI.

#### 11.2.2.2.3 *mau\_available* message

The MAU Physical Layer sends a *mau\_available* message to the DTE Physical Layer when the MAU is available for output. The *mau\_available* message is always sent by an MAU that is prepared to output data. The physical realization of the *mau\_available* message is an IDL signal sent by the MAU to the DTE on Circuit CI.

#### 11.2.2.2.3 *signal\_quality\_error* message

The *signal\_quality\_error* message shall be implemented in the following fashion:

- a) The *signal\_quality\_error* (SQE) message shall not be sent by the MAU if no or only one MAU is transmitting a legal length packet (as specified in this standard) on the coaxial medium, except as a part of the SQE self test.

- b) If the MAU connected to the local node is not transmitting, then the local MAU shall send the *signal\_quality\_error* message in every instance when it detects power in the collision enforcement band earlier than the time equivalent for reception of a 512 bit data frame plus preamble and SFD.
- c) When the local MAU is transmitting on the coaxial medium, all occurrences of one or more additional MAUs transmitting shall cause the *signal\_quality\_error* message to be sent by the local MAU to the attached DTE.
- d) When the MAU has completed a successful transmission of a packet it shall perform an SQE Test sequence. In this instance, the collision enforcement RF signal is interpreted as an SQE Test signal.

### 11.2.3 MAU state diagrams

The operation of the MAU during normal transmission and reception can be described by a state diagram that relates the functions of transmission, reception, collision detection, and collision detection testing. Figure 11–4, at the end of this subclause, shows the state transitions for normal operation. Abnormal conditions are implementation-specific.

The state diagram in Figure 11–4 does not describe the operation of the MAU in detail. This is found in 11.2 and 11.3.

The operation of the Jabber function is described by the state diagram of Figure 11–5. When the MAU Jabber state machine is in the INTERRUPT or JAB state, outputs of the MAU Jabber state machine shall override those of the MAU state machine.

#### 11.2.3.1 MAU state diagram messages

The following messages are used in the state diagram:

- a) *disable\_data\_driver*. Deactivates the mechanism by which the RF data signal is impressed onto the coaxial cable.
- b) *enable\_data\_driver*. Activates the mechanism by which the RF data signal is impressed onto the coaxial cable.
- c) *disable\_CE\_driver*. Deactivates the mechanism by which collision enforcement RF signals are impressed onto the coaxial cable.
- d) *enable\_CE\_driver*. Activates the mechanism by which collision enforcement RF signals are impressed onto the coaxial cable.
- e) *mau\_available*. Signifies that the MAU is available for transmission (that is, there is no SQE active).
- f) *signal\_quality\_error* (SQE). Signifies that the MAU has detected a collision, it has successfully completed the SQE Test sequence, or the jabber circuit is active.
- g) *start\_SQE\_test\_timer*. Causes a timer to begin counting so that the SQE Test signal may be sent to the coaxial cable interface.
- h) *positive\_disable*. Prevents any RF signal from being sent onto the coaxial cable.

#### 11.2.3.2 MAU state diagram signal names

The signal names used in the state diagram are as follows:

- a) *PowerOn*. This signal signifies that power has been applied to the unit.
- b) *rx\_energy*. When this signal is active, an RF signal on the coaxial cable has been detected either in the data band or in the collision enforcement band or in both. The delay in asserting or de-asserting this signal is sufficiently short that the delays specified in 11.3.4.5 are met.
- c) *output*. Signifies that data from the DTE is being presented for transmission at the AUI.
- d) *tx\_umd* (Transmit Unscrambled Mode Delimiter). When the Unscrambled Mode Delimiter has been detected in the transmit data sequence, this signal is asserted.

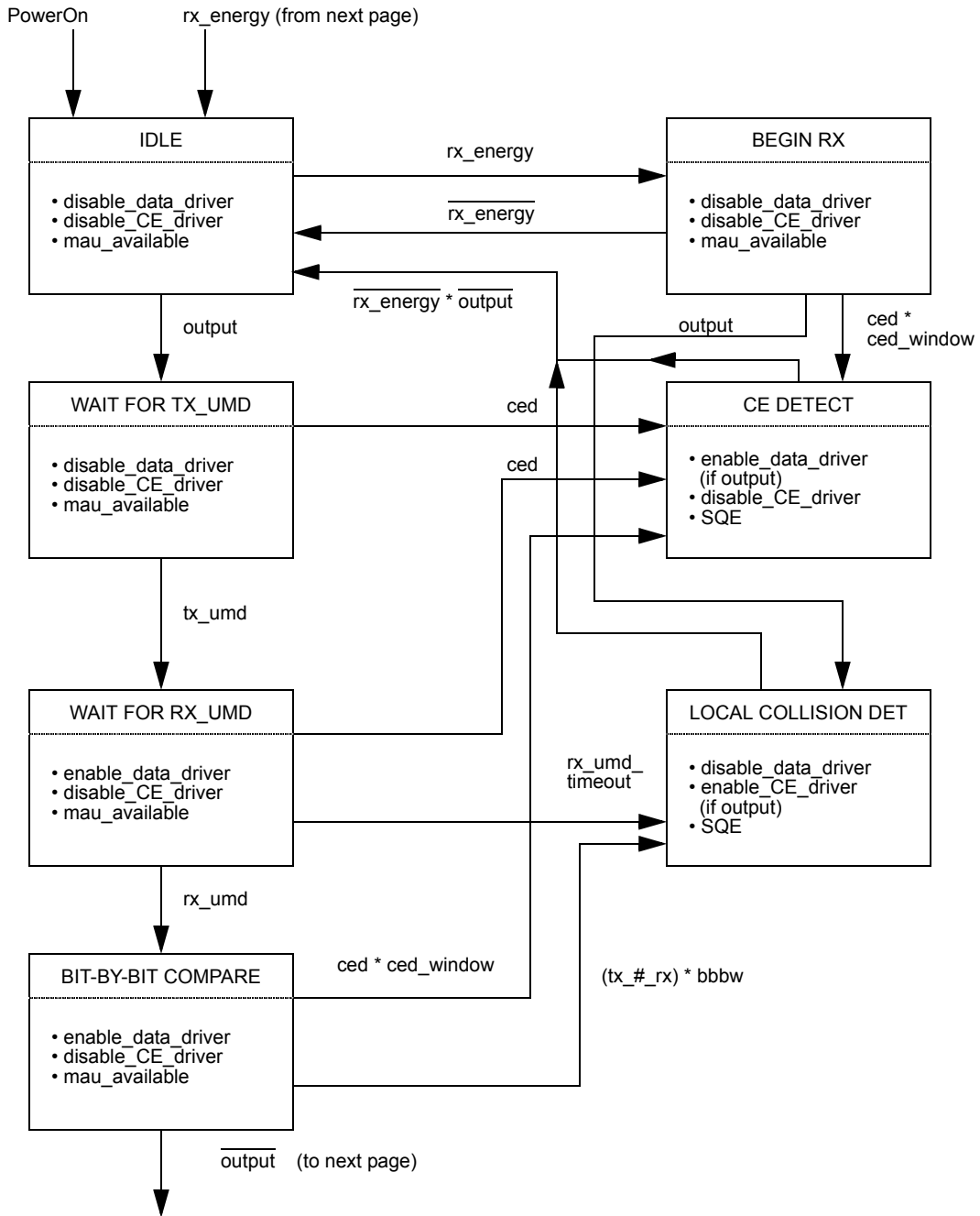
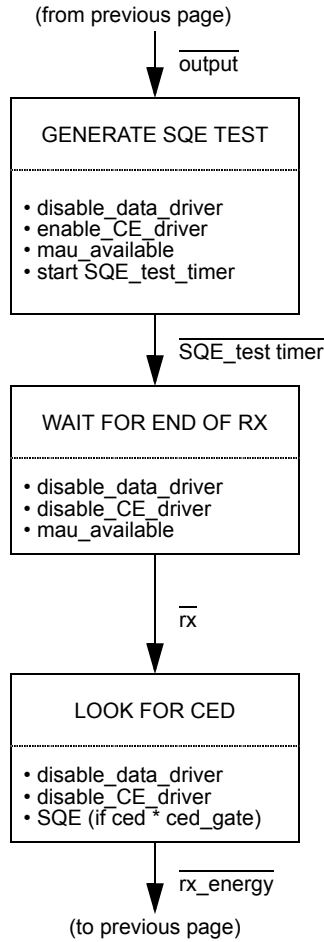
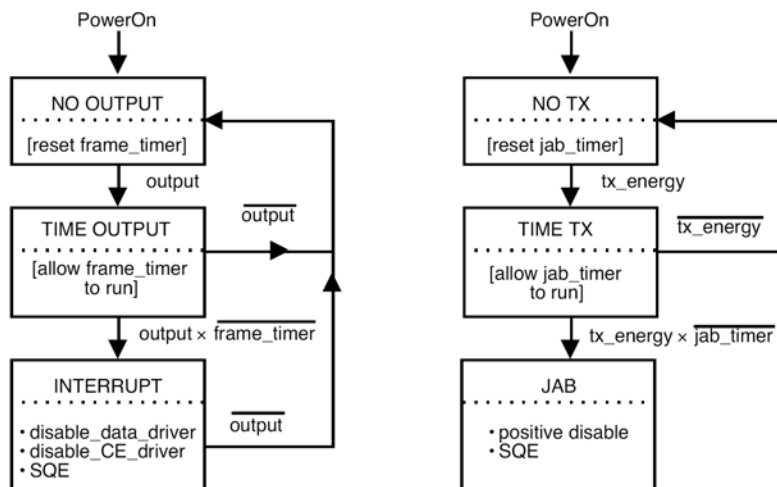


Figure 11-4—MAU state diagram

- e) `rx_umd` (Receive Unscrambled Mode Delimiter). When the Unscrambled Mode Delimiter has been detected in the receive data sequence as it is conveyed from the coaxial cable interface, this signal is asserted.
- f) `SQE_test_timer`. This signal is on during the time that the SQE Test Timer is engaged. At the end of the time, this signal is de-asserted.
- g) `rx` (Receive). As long as data is being presented by the MAU to Circuit DI of the AUI, this signal is active. When the last bit of the receive data has been presented to the AUI, this signal is de-asserted.
- h) `ced` (Collision Enforcement Detection). RF signal power in the collision enforcement band causes this signal to be asserted.



**Figure 11-4—MAU state diagram (continued)**



**Figure 11-5—MAU jabber state diagram**



- i) **ced\_window** (Collision Enforcement Detection Window). This signal defines a period of time (a “window”) during which collisions may occur. Its purpose is to distinguish collision enforcements from SQE Test sequences on the coaxial cable. The window opens when **rx\_energy** goes active and closes a minimum of 365 bit times later. The maximum time the window may be open is the minimum frame length, plus preamble and SFD: 576 bits.
- j) **rx\_umd\_timeout** (Receive Unscrambled Mode Delimiter Timeout). It is possible that the Receive Unscrambled Mode Delimiter may be corrupted by a collision such that the bit-by-bit comparison may not begin. This signal forces detection of a collision due to failure to detect the **rx\_umd** within a maximum time. The timeout begins upon receipt of RF signal in the data band and expires 32 bit times later.
- k) **tx\_#\_rx** (Transmit Not Equal to Receive). Assertion of this signal occurs when a difference is detected between the received data stream and the transmitted data stream.
- l) **bbbw** (Bit-by-Bit Window). Bit-by-bit comparison shall be performed only for a time long enough to guarantee that the last bit of the source address has been examined. This signal is asserted after the UMD is received and throughout the bit-by-bit comparison process. To place a bound on the location of the source address relative to the UMD, the maximum preamble length permitted for operation with the broadband MAU is 62 bits. This places the last bit of the source address no later than 143 bits after the UMD.
- m) **ced\_gate**. This signal is a gating function that serves to shape the timing of **ced** during an SQE Test. It becomes true a minimum of 6 and a maximum of 16 bit times after the last bit has been presented to Circuit DI and stays active 10 bit times  $\pm$  5 bit times.
- n) **tx\_energy**. This signal signifies that the MAU is attempting to transmit an RF signal onto the coaxial cable.
- o) **frame\_timer**. This signal is on from the beginning of output until it is reset or until it has been on continuously for **timeout1** s. The value of **timeout1** shall be greater than 20 ms and less than **timeout2**.
- p) **jab\_timer**. This signal turns on when **tx** energy turns on and lasts until it is reset or until it has been on continuously for **timeout2** s. The value of **timeout2** shall be greater than **timeout1** and less than 150 ms.

## 11.3 MAU characteristics

### 11.3.1 MAU-to-coaxial cable interface

The following subclauses describe the interface between the MAU and the broadband coaxial medium. The medium is a 75  $\Omega$  CATV-type broadband cable installation employing a single bidirectional cable with band-split amplifiers and filters, or dual unidirectional cables with line amplifiers.

#### 11.3.1.1 Receive interface

##### 11.3.1.1.1 Receive input impedance

The nominal input impedance at the receive port shall be 75  $\Omega$ . The return loss within the data and collision enforcement frequency bands shall be at least 14 dB with power applied to the MAU.

##### 11.3.1.1.2 Receiver squelch requirements

There shall be a receiver squelch that inhibits reception of RF signals that are too low in level. This squelch shall permit reception of RF data or collision enforcement signals that are greater than or equal to  $-7$  dBmV rms as measured by the method of 11.3.1.2.5. RF signals (data, collision enforcement, noise, or other signals) of levels lower than  $-15$  dBmV rms shall be ignored.

The receive squelch for CE signals shall be derived from a power detector with noise bandwidth greater than or equal to 1.5 MHz centered at the CE center frequency.

#### **11.3.1.1.3 Receive level requirements**

The receiver shall operate with RF data and CE signals having levels from  $-4$  dBmV to  $+16$  dBmV rms. The nominal receive level shall be  $+6$  dBmV rms.

#### **11.3.1.1.4 Receiver selectivity and linearity requirements**

The MAU shall operate in the presence of single frequency (CW) signals adjacent to the receive band of the MAU and offset from the band edges, received at the following levels:

- a) 0 dBmV rms at 0.25 MHz below and above the band
- b) 10 dBmV rms at 1.25 MHz below and above the band

The receiver shall be capable of operating in a cable environment loaded with TV signals (for example, every 6 MHz in the USA). The TV signals shall be no higher than  $+10$  dBmV peak video at the receiver coaxial cable interface.

#### **11.3.1.1.5 Receive input mechanical requirements**

The receiver mechanical interface shall be a  $75\ \Omega$  female F-series coaxial connector. The connection to the broadband medium shall be through a coaxial drop cable with a mating male F-series connector. For single-cable configurations, the same connector may be used for receive and transmit.

#### **11.3.1.2 Transmit interface**

##### **11.3.1.2.1 Transmit output impedance**

The nominal output impedance at the transmit port shall be  $75\ \Omega$ . The return loss within the data and collision enforcement frequency bands shall be at least 14 dB with power applied.

##### **11.3.1.2.2 Transmitted RF packet format**

Figure 11–6 shows the transmitted RF packet format.

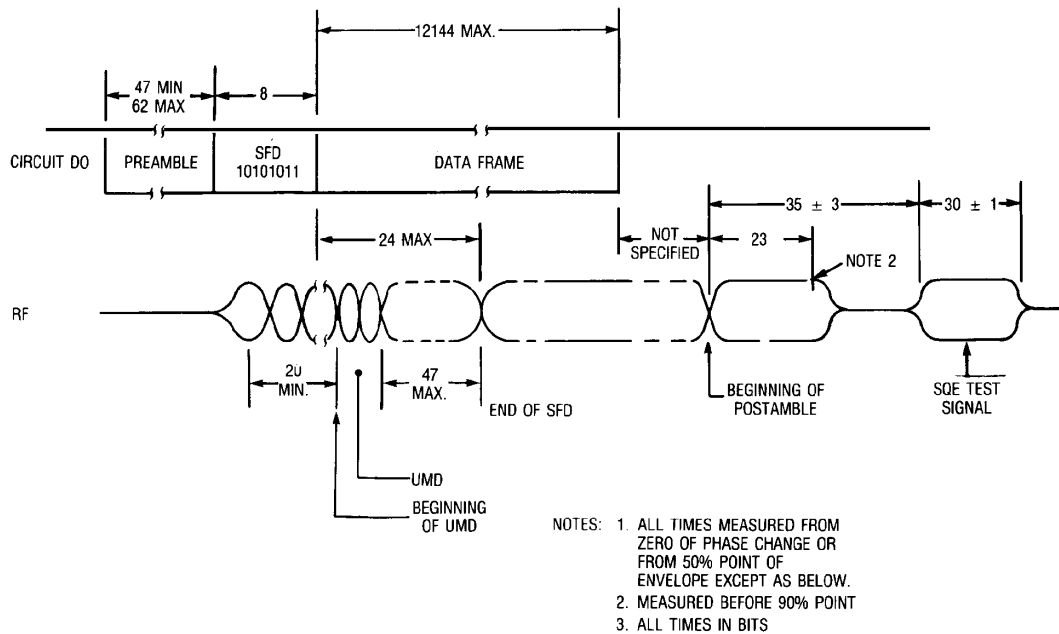


Figure 11-6—Packet format and timing diagram (AUI to coaxial cable interface)

### 11.3.1.2.3 Transmit spectrum and group delay characteristics

The transmit RF data signal shall be binary phase-shift-keyed (PSK) modulated and shall have a frequency spectrum equivalent to baseband raised-cosine Nyquist filtering with a rolloff factor ( $a$ ) of 0.4, and within the limits of Figure 11-7. For rectangular pulses, the filter characteristic is

$$H(j\omega) \begin{cases} \frac{\omega(T/2)}{\sin(\omega T/2)}; & \left[ 0 \leq \omega < \frac{\pi}{T}(1-a) \right] \\ \frac{\omega(T/2)}{\sin(\omega T/2)} \cos^2\left(\frac{T}{4a}\left[\omega - \frac{\pi(1-a)}{T}\right]\right); & \left[ \frac{\pi}{T}(1-a) \leq \omega < \frac{\pi}{T}(1+a) \right] \\ 0; & \left[ \omega \geq \frac{\pi}{T}(1+a) \right] \end{cases}$$

where  $T$  = one symbol time (100 ns for 10 Mb/s) and  $a = 0.4$ , and the first term accounts for the  $\sin x/x$  spectrum of NRZ random data.

The total variation in group delay from Circuit DO to the RF coaxial medium interface shall not exceed 20 ns in the frequency band from the carrier frequency to  $\pm 5$  MHz, and 32 ns to  $\pm 5.5$  MHz.

The collision enforcement (CE) signal shall be a constant amplitude pulse with controlled turn-on and turn-off times. Random modulation may be added to reduce the probability of cancellation when more than one CE signal is received simultaneously. The modulated signal shall have an instantaneous frequency within 0.75 MHz of the CE band center frequency and shall conform to the spectrum mask specified in 11.3.1.2.4. The random modulation may be derived from the transmit NRZ data stream.

The CE signal rise and fall times shall approximate a Gaussian shape of the form

$$f(t) = \exp\left(-\frac{1}{2}\left[\frac{t}{T}\right]^2\right)$$

where  $T$  = one symbol time and  $t < 0$  for the rise time and  $t > 0$  for the fall time.

The CE and data RF signals shall not be transmitted simultaneously.

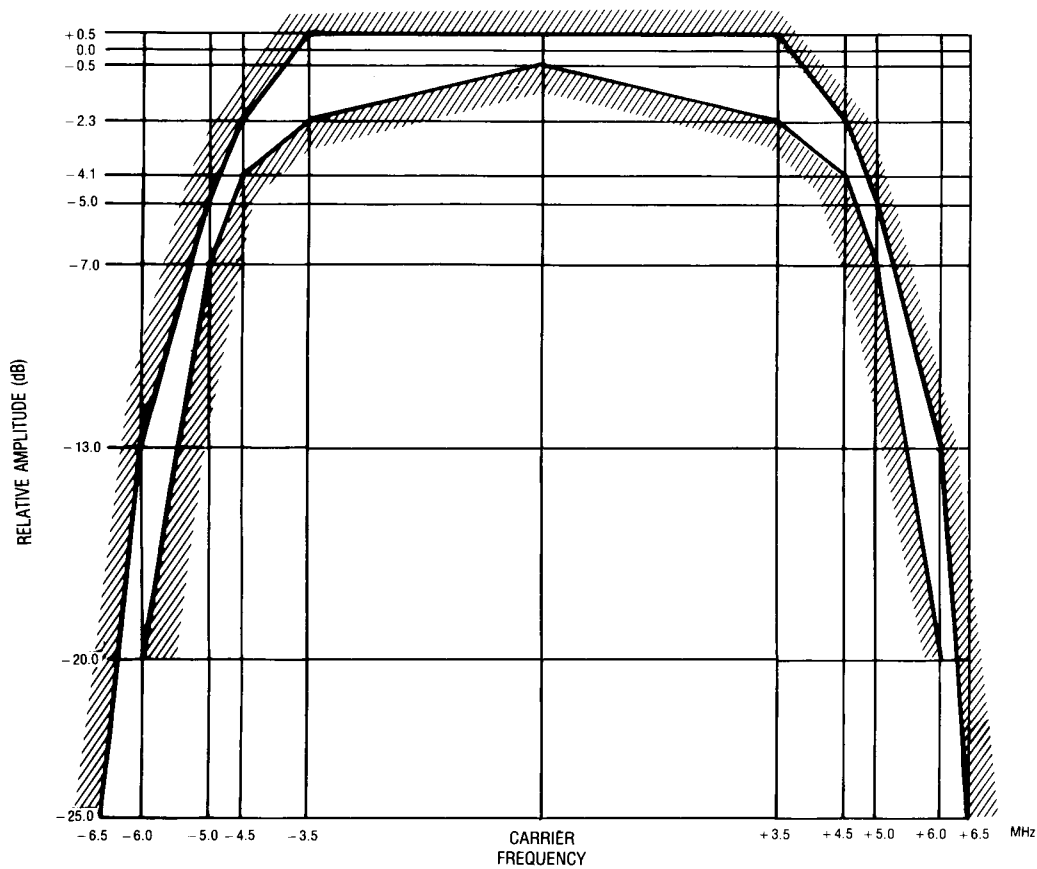


Figure 11-7—Spectrum mask for RF data signal

### 11.3.1.2.4 Transmit out-of-band spectrum

The transmitted power outside the specified band shall meet or exceed the relative attenuation (RA) specified below, under the following conditions:

- Transmitted packet length is 256 bits with a 25.6  $\mu$ s interval between packets, for 50% duty cycle on the cable.
- Reference level is an unmodulated carrier, equivalent to the postamble transmitted level.
- RA is the attenuation in decibels relative to the reference level outside the specified band, measured in a 30 kHz noise bandwidth with a video filter of 300 Hz bandwidth or less.
- B is 18 MHz, the width of data plus collision enforcement bands.
- MF is the measurement frequency in MHz.
- NCEF is the frequency of the nearest edge of the band, in MHz.

$$RA = \min(63, 55 + 30 \times |(MF - NCEF) / B|)$$

Figure 11–8 graphically shows the attenuation requirement for out-of-band power.

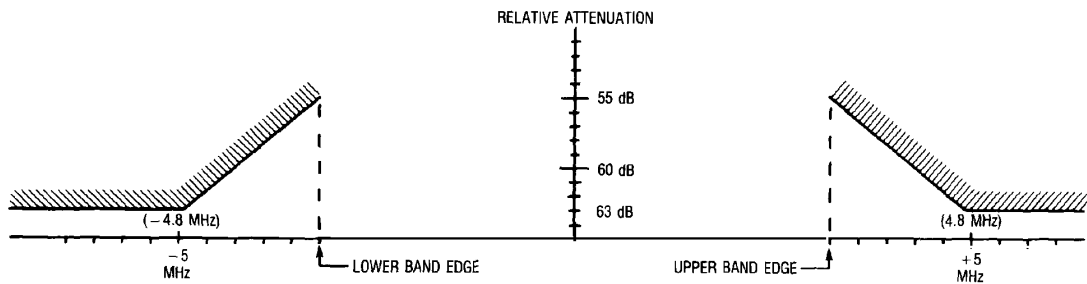


Figure 11–8—Transmit out-of-band power attenuation

### 11.3.1.2.5 Transmit level requirements

The transmitter output power during the postamble and during the SQE Test of the collision enforcement signal shall be 1000 mV peak-to-peak into a 75  $\Omega$  load (51 dBmV rms). Truncation loss due to the specified data filtering is 1 dB; transmitted RF data signal power is 50 dBmV rms. Transmit output power variations shall not exceed  $\pm 2$  dB.

### 11.3.1.2.6 Nontransmitting signal leakage requirement

The RF data signal and collision enforcement signal leakage to the coaxial cable interface while the MAU is not in its transmission mode shall be less than  $-20$  dBmV rms.

### 11.3.1.2.7 Transmit spurious output requirement

All spurious signals from the transmitter (inband and out-of-band) while not transmitting shall be less than  $-20$  dBmV rms. All spurious signals from the transmitter while transmitting data or collision enforcement shall be below the spectrum mask specified in 11.3.1.2.4.

### 11.3.1.2.8 Collision enforcement signal leakage requirement

The collision enforcement RF signal leakage to the coaxial cable during data transmission and while the MAU is not enforcing collisions shall be less than 5 dBmV rms. Leakage shall be less than -20 dBmV rms when the MAU is not in the transmission mode.

### 11.3.1.2.9 Transmit output mechanical requirements

The transmit mechanical interface shall be a 75 Ω female F-series coaxial connector. The connection to the broadband medium shall be through a coaxial drop cable with a mating male F-series connector. For single cable installations, the same connector may be used for transmit and receive.

## 11.3.2 MAU frequency allocations

The broadband MAU uses a data band 14 MHz wide and an adjacent collision enforcement band 4 MHz wide. A single cable midsplit configuration with a frequency offset of 156.25 MHz or 192.25 MHz between forward and reverse channels is recommended. Other configurations, including dual-cable, where forward and reverse channels are on separate unidirectional cables, also are permitted.<sup>29</sup> The preferred pairing for the usual North American 6 MHz channels is specified in Table 11-1 and Table 11-2. The tables also specify the data carrier or collision enforcement center frequency for each band, and for single-cable systems, the frequency translation and the headend local oscillator frequency.

### 11.3.2.1 Single-cable systems frequency allocations

Table 11-1 lists the permissible frequency band allocations for single-cable systems. The 192.25 MHz translation is recommended for all new designs. The 156.25 MHz translation is allowed for compatibility with some existing systems. The 156.25 MHz translation results in a reversal of the data and collision enforcement bands, as the lower sideband is used.

**Table 11-1—Single-cable frequency allocations (frequencies in MHz)**

TRANSMITTER			RECEIVER			
Data carrier	Coll enf center freq	Transmit band	Translation 156.25 MHz		Translation 192.25 MHz	
			Headend local osc	Receive band	Headend local osc	Receive band
43	52	35.75-53.75	245.75	192-210	192.25	228-246
49	58	41.75-59.75	257.75	198-216	192.25	234-252
55	64	47.75-65.75	269.75	204-222	192.25	240-258
+61	70	53.75-71.75	281.75	210-228	192.25	246-264
67	76	59.75-77.75	293.75	216-234	192.25	252-270
73	82	65.75-83.75	305.75	222-240	192.25	258-276

NOTE 1—Some of these optional bands are overlapping.

NOTE 2—Frequency tolerance of the data carrier and headend local oscillator shall each be ± 25 kHz.

NOTE 3—+ denotes the preferred frequency allocation.

<sup>29</sup> The remainder of 11.3.2 and all of 11.3.2.1 and 11.3.2.2 are not part of the ISO/IEC International Standard. Frequency allocations are a subject for national standardization.

### 11.3.2.2 Dual-cable systems frequency allocations<sup>30</sup>

In nontranslated dual-cable systems transmit and receive frequencies are identical. Table 11–2 lists the permissible frequency band allocations. In some instances translated dual-cable systems are installed. In such cases the single-cable frequency allocations may be used.

**Table 11–2—Dual-cable frequency allocations (frequencies in MHz)**

Data carrier	Coll enf center freq	Data band	Coll enf band
43	52	36–50	50–54
49	58	42–56	56–60
55	64	48–62	62–66
+61	70	54–68	68–72
67	76	60–74	74–78
73	82	66–80	80–84
235.25	244.25	228–242	242–246
241.25	250.25	234–248	248–252
247.25	256.25	240–254	254–258
253.25	262.25	246–260	260–264
259.25	268.25	252–266	266–270
265.25	274.25	258–272	272–276

NOTE 1— Some of these optional bands are overlapping.

NOTE 2—Frequency tolerance of the data carrier shall be  $\pm 25$  kHz.

NOTE 3— + denotes the preferred frequency allocations.

### 11.3.3 AUI electrical characteristics

#### 11.3.3.1 Electrical isolation requirements

The MAU must provide isolation between the AUI cable and the broadband coaxial medium. The isolation impedance shall be greater than 250 k $\Omega$  at 60 Hz, measured between any conductor (including shield) of the AU Interface cable and either the center conductor or shield of the coaxial cable. The isolation means provided shall be able to withstand 500 Vac rms for one minute.

The MAU power supply, if provided, shall meet the appropriate national requirements. See IEC 950: 1991 for guidance.

#### 11.3.3.2 Current consumption

The MAU may have its own power supply but is also allowed to use the power supplied by the DTE through the AUI cable. When drawing current from the AUI, the current shall not exceed 0.5 A as provided by the AUI source. The MAU shall be capable of operating from all possible voltage sources as supplied by the DTE through the resistance of all permissible AUI cables. The MAU shall not disrupt the broadband coaxial medium should the DTE power source fall below the minimum operational level under abnormal MAU load conditions. The MAU shall be labeled externally to identify the nominal value of current required by the device at the AUI.

<sup>30</sup> See Footnote 29.

### 11.3.3.3 Driver and receiver requirements

The requirements for AUI cable driver and receiver components within the MAU are identical with those specified in Clause 7 of this standard. The drivers shall provide signals that meet the symmetry and jitter requirements of Circuit DI defined in Clause 7 and the receivers shall accept signals that have traversed the worst-case lengths of AUI cable.

### 11.3.3.4 AUI mechanical connection

The MAU shall be provided with a 15-pin male connector as specified in detail in the PLS/AUI specifications, in 7.6 of this standard.

### 11.3.4 MAU transfer characteristics

Signals presented on Circuit DO are transformed into signals at the coaxial cable interface by delaying them and by reformatting them. Signals at the coaxial cable interface are transformed into signals on Circuit DI and Circuit CI by a different framing change and by additional delay.

#### 11.3.4.1 AUI to coaxial cable framing characteristics.

Data presented on Circuit DO shall first be received differentially, then Manchester decoded into an NRZ data stream. The framing of the data shall then be transformed into a new packet for presentation to the RF modulator in the following way (see Figure 11–6 and Figure 11–9):

- a) Up to 5 bits of the incoming data stream may be dropped for detection and Manchester decoding purposes.
- b) Beginning with the first zero, 20 bits of zero-one pattern shall be sent for receiver synchronization and clock recovery.

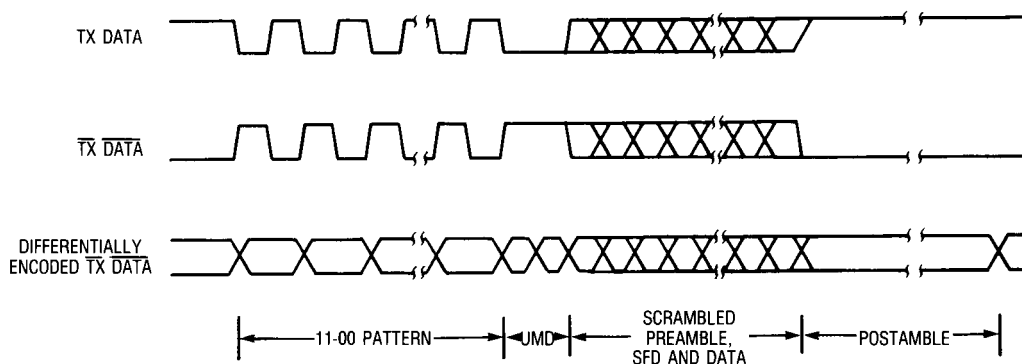


Figure 11–9—Packet format at modulator input

- c) The next two bits (zero-one in the incoming pattern) shall both be set to zero and form the Unscrambled Mode Delimiter (UMD). The UMD shall take the place of the zero-one in the incoming pattern; it shall not be inserted into the data stream.
- d) All remaining bits in the preamble, SFD, and data fields shall be scrambled (using a CCITT V.29 scrambler plus a differential encoder per 11.3.4.1).
- e) A postamble (BEOFD) consisting of a zero followed by 22 ones shall be added immediately after the last scrambled data bit (the postamble is not scrambled). The postamble may be extended to allow controlled turnoff of the transmitted signal, as shown in Figure 11–6.



- f) All bits (unmodified preamble; UMD; scrambled preamble, SFD, and data; and postamble) are inverted.
- g) All bits sent to the RF modulator are differentially encoded. Figure 11–9 shows the appearance of the data before and after the differential encoder.
- h) The SQE Test sequence shall be generated after a successful data transmission by transmitting a collision enforcement RF signal with the timing shown in Figure 11–6.

Because the preamble of the incoming data on Circuit DO is modified, it is assumed that DTEs generate a minimum length preamble of 47 bits. The maximum preamble length is allowed to be 62 bits, as shown in Figure 11–6.

#### 11.3.4.1.1 Scrambler and differential encoding requirements

The NRZ data shall be scrambled (using a CCITT V.29-type scrambler). A new seed shall be used by the scrambler for every new packet presented by the DTE to the MAU. Figure 11–10 is a diagram of a typical scrambler implementation.

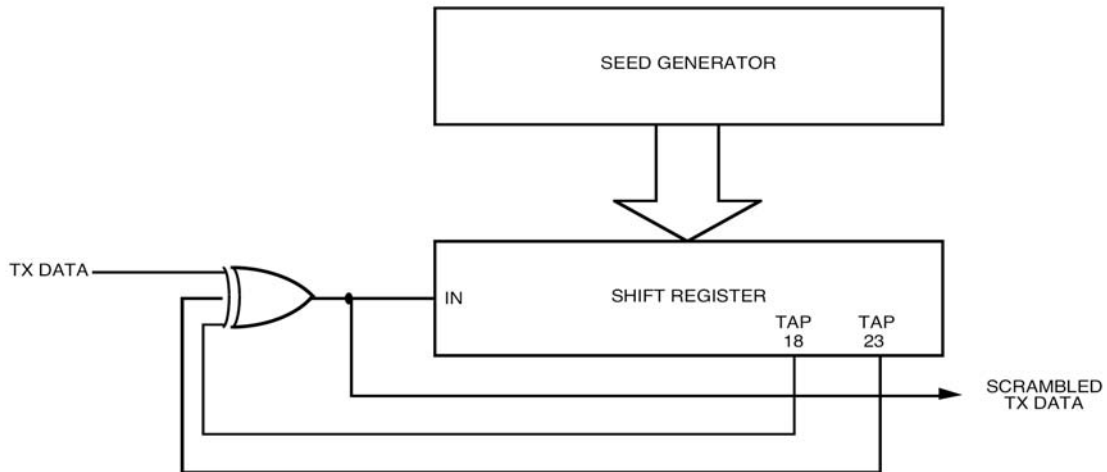


Figure 11–10—Scrambler

The scrambled NRZ data shall be differentially encoded (see Figure 11–11 for a typical implementation).

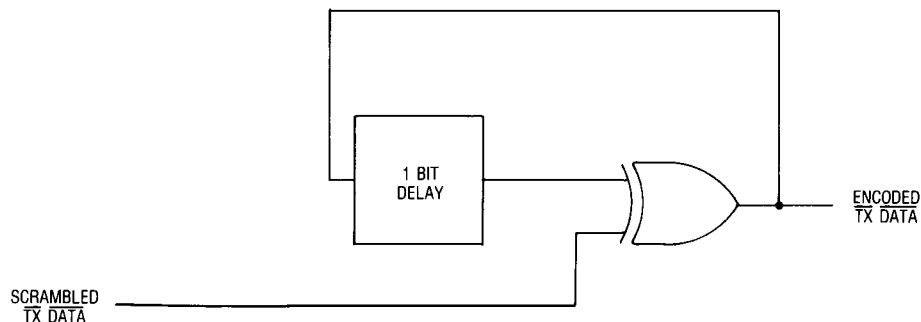


Figure 11–11—Differential encoder

The entire encoding process comprising the scrambling and differential encoding is essentially equivalent to a division of the polynomial representing the data to be transmitted by the following polynomial:

$$G(x) = 1 + x^{-1} + x^{-18} + x^{-19} + x^{-23} + x^{-24}$$

#### 11.3.4.2 Coaxial cable to AUI framing characteristics

The MAU shall demodulate, differentially decode, and invert the received RF data signal to recover the scrambled and inverted data stream. Clock shall be recovered and a replica of the unfiltered and noninverted transmitted data stream shall be created. The restored data shall be forced to a logic “one” state whenever no RF data signal is detected. This prevents false UMD detection and forces postamble detection when no carrier is present.

The framing information contained in the RF data stream shall be used to reconstruct the received data so that no more than 6 bits are lost and no more than one bit added to the preamble field, and no bits are added to or lost from the end of the transmit data. Detection of the UMD in the receive data shall initiate, after a fixed delay, a locally generated preamble sequence of zero-one pattern. This pattern “fills in” the preamble bits altered due to the framing information at the beginning of the packet: the zero-one synchronization and clock recovery sequence, the UMD, and the descrambler synchronization sequence.

The MAU shall descramble the received data using a self-synchronizing (CCITT V.29-type) descrambler. No prior knowledge of the seed used by the scrambler shall be assumed by the descrambler circuit. The descrambler shall have valid output no later than 23 bit intervals after the UMD is detected by the receiver. An example of a descrambler is shown in Figure 11–12. The differential decoding performed by the demodulator and the descrambling function are essentially equivalent to multiplying the received polynomial by  $G(x)$  as defined in the scrambling and differential encoding requirements subclause above.

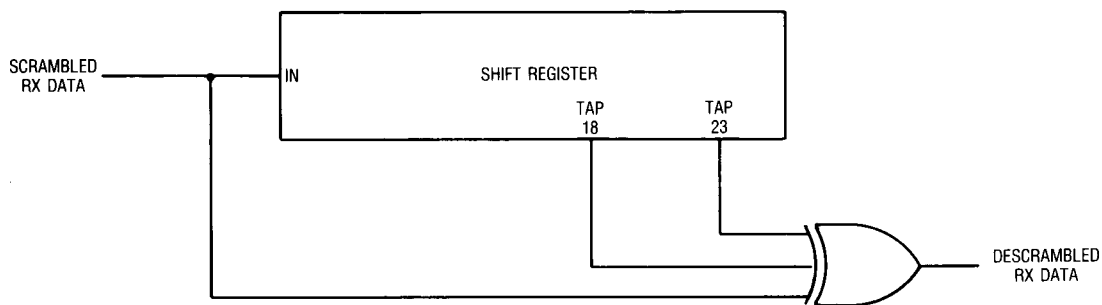


Figure 11–12—Descrambler

After the descrambler is synchronized, 23 bits after the UMD, the correctly descrambled receive data, starting with the 24th bit after the UMD, shall be transferred to the Manchester encoder and therefrom to the AUI. The delay from the detection of the UMD to the beginning of the locally generated zero-one pattern shall be chosen so that no more than 6 bits of preamble are lost, and no more than one bit added, in transmission from Circuit DO to Circuit DI.

The MAU shall detect the “zero” followed by 22 “ones” (the postamble pattern) and, in conjunction with the loss of carrier detection in the data band or the presence of a collision enforcement detection signal, shall ensure that the packet presented to the local DTE has no extraneous bits added by the MAU to the end of the packet.

The SQE Test signal shall be detected on the RF interface and the SQE signal shall be presented to Circuit CI of the transmitting MAU, subject to the timing restrictions of 11.3.4.5.4. If the signal is not observed at the RF interface due to failure of any element in the transmitter or receiver, no SQE signal may be presented to the AUI. In the event of a collision enforcement, energy will appear in the collision enforcement band within the `ced_window` time after energy first appears in the data band. Circuit CI shall be asserted when collision enforcement is first detected and shall continue to be active until after the RF signal on the RF port has subsided. Note that an SQE Test signal appended to a packet whose length is less than the `ced_window` time (less than the minimum allowed packet length) will be indistinguishable from a collision enforcement, except by the MAU transmitting. The transmitting MAU shall take this into account and shall not interpret energy in the collision enforcement band to be a collision when the length of the transmitted packet is less than the `ced_window` time and the SQE Test sequence has been transmitted. See the discussion in 11.4.2 for more information on `ced_window`.

#### **11.3.4.3 Circuit DO to circuit DI framing characteristics**

In the absence of a collision, the packet format of the receive data at the AUI is identical to that of the transmit data, except that there may be one more preamble bit than was sent at the transmit port and up to 6 bits of the preamble lost. In the presence of a collision, the receive data is undefined, but shall still be properly Manchester encoded.

#### **11.3.4.4 AUI to coaxial cable delay characteristics**

The timing and delays associated with the transmitter of the MAU are identified below. To ensure compatibility with all MAUs the delays identified below cannot be exceeded nor traded off with other delays in the system.

##### **11.3.4.4.1 Circuit DO to RF data signal delay**

The delay from a transition on Circuit DO at the end of a bit to the corresponding phase change of the RF data signal (such bit chosen so that an RF burst phase change does exist) shall be no more than 24 bit times. The delay from the first transition on Circuit DO to the first appearance of RF energy, however, is not specified except as it is determined by other timing constraints.

##### **11.3.4.4.2 Circuit DO to CE RF output delay**

In the event that the MAU begins receiving energy on the coaxial medium just before the DTE presents data to the AUI, a collision shall be detected locally, as described in Figure 11–4. The delay from the first bit at Circuit DO of the AUI to the presentation of collision enforcement at the coaxial cable interface in this circumstance shall be 32 bit times maximum.

##### **11.3.4.4.3 Transmit postamble to SQE test signal delay**

The delay from the initial transition of the first bit of the postamble (Broadband End of Frame Delimiter) measured at the RF port to the 50% point of the rising edge of the SQE Test signal shall be 35 bit times  $\pm$  3 bit times.

##### **11.3.4.4.4 SQE test signal length**

The SQE Test signal length shall be 30 bit times  $\pm$  1 bit time as measured at the 50% points of the RF signal.

#### **11.3.4.5 Coaxial cable to AUI delay characteristics**

The MAU receiver timing and delays described below shall not be exceeded or traded off against any other delays in the system.

### 11.3.4.5.1 Received RF to circuit DI delay

When there is no collision in progress, the delay from the end of the SFD in the received RF data signal at the coaxial cable interface to the end of the SFD on Circuit DI, shall be a maximum of 75 bit times (see Figure 11–13). The minimum is not specified, nor is the delay specified at other locations in the packet. The end of the SFD in the received RF data signal (at the coaxial cable interface) is defined as the time at which the envelope of the carrier would pass through the midpoint if the first bit following the SFD was a zero and the scrambler disabled.

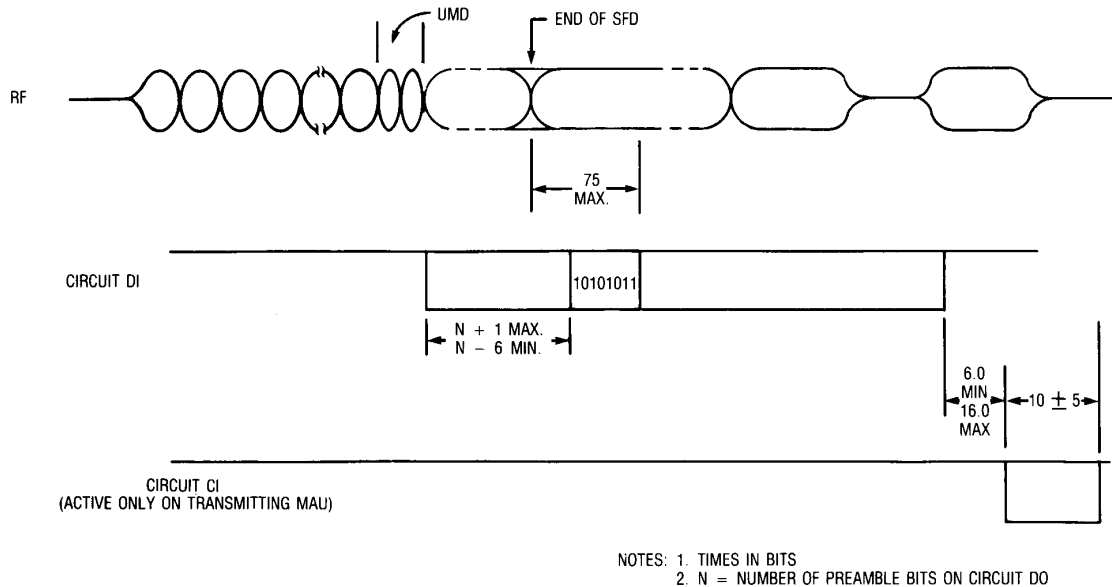


Figure 11–13—No collision timing diagram (coax to AUI)

### 11.3.4.5.2 Received RF to CE RF output and circuit CI delay

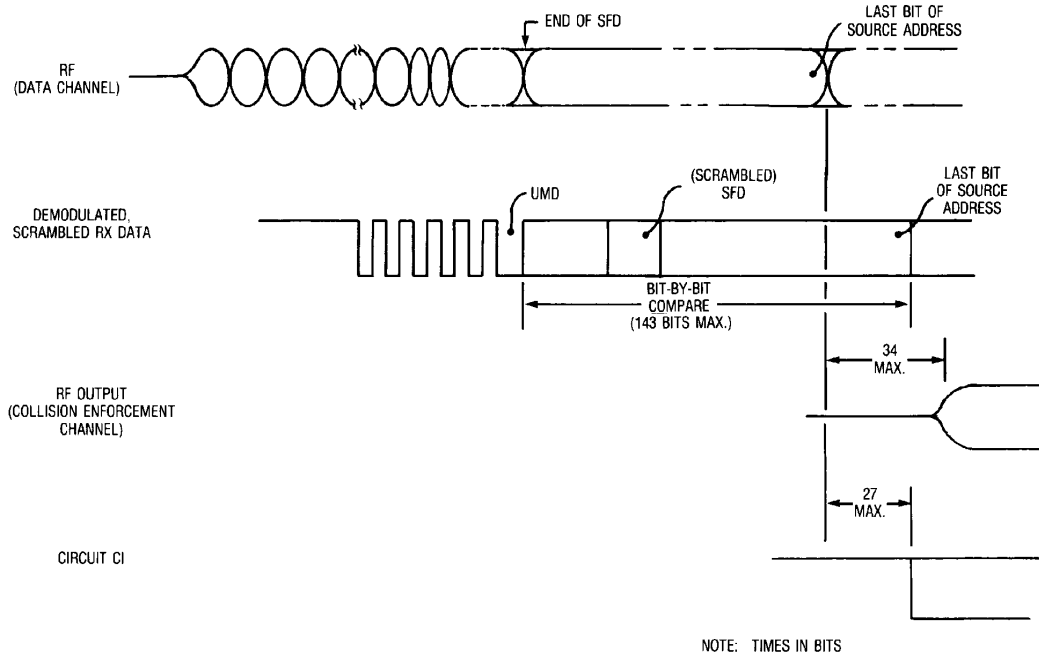
In the event that a collision is detected via the bit-by-bit comparison, the delay from the end of the bit in which the collision was detected, as represented by the RF signal, to the 50% point on the rising edge of the collision enforcement signal shall not exceed 34 bit times. The delay from the same point to the first transition of Circuit CI shall not exceed 27 bit times. Circuit CI shall cease activity no more than 31 bit times after activity on the RF interface (in both data channel and collision enforcement channel) ceases. See Figure 11–14 and Figure 11–15.

### 11.3.4.5.3 Collision enforcement to circuit CI delay

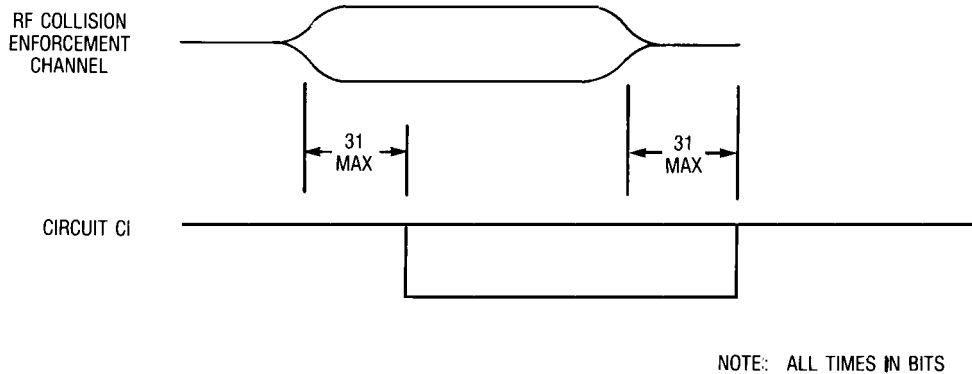
In the event of a collision enforcement by another MAU, the delay from the 50% point on the rising edge of the RF collision enforcement signal to the first transition of Circuit CI shall be no more than 31 bit times. Circuit CI shall be active for a minimum of 5 bit times and shall become inactive within 31 bit times of the cessation of activity on the RF coaxial cable interface, as shown in Figure 11–15.

### 11.3.4.5.4 Receive data to SQE test delay

If a collision enforcement signal is received after the `ced_window` signal becomes inactive [see item i) in 11.2.3.2], or if the MAU has transmitted an SQE Test sequence, the MAU is to interpret the collision enforcement signal as an SQE Test signal. If the SQE Test sequence is correctly detected (that is, the test passes), then the delay from the last transition of Circuit DI to the first transition of Circuit CI shall be at



**Figure 11-14—Collision timing diagram (RF data to RF collision enforcement)**



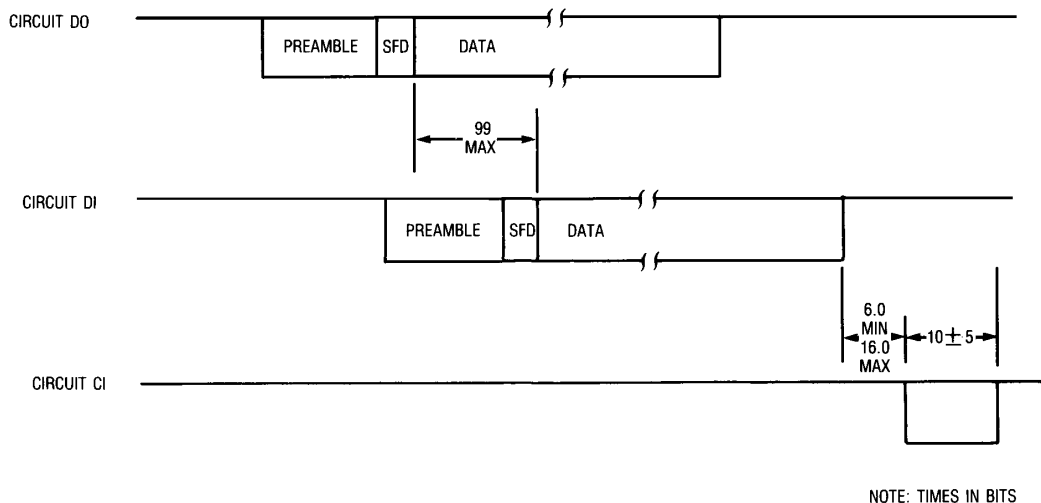
**Figure 11-15—Collision timing diagram (coaxial cable interface to AUI circuit)**

least 6 but not more than 16 bit times. Circuit CI shall remain active for 10 bit times  $\pm$  5 bit times. Only the transmitting MAU shall assert its Circuit CI as a result of successful completion of the SQE Test sequence.

If a collision enforcement signal is received before the ced\_window signal becomes inactive, the MAU shall interpret it as a collision enforcement and the timing of 11.3.4.5.3 shall apply.

#### 11.3.4.6 Delay from circuit DO to circuit DI

The time delay from a bit on Circuit DO at the AU Interface to the corresponding bit on Circuit DI at the AU Interface is equal to the round trip delay of the MAU connected back-to-back with itself (that is, in RF loop-back) plus the round trip delay through the cable system at the location of the MAU. Therefore, the delay is a function of the location of the MAU on the cable system. It is never less than the transmitter delay plus the postamble length plus the time to detect loss of carrier or presence of the SQE Test signal. See Figure 11-16 for the timing relationship when the cable has zero length.



**Figure 11–16—Timing at AUJ for zero-length coax**

When the MAU is transmitting a short packet (less than 576 bits), the timing for Circuit CI during the SQE Test sequence shall be the same as it is for normal length packets. If the MAU transmits a short packet (less than 576 bits) that encounters a collision and if the SQE Test sequence has not been transmitted when the collision is detected by the MAU, then the timing for Circuit CI shall be the same as it is for any normal collision.

**11.3.4.7 Interpacket gap requirement**

The MAU shall be able and ready to transmit data presented to it by the DTE no later than 90 bit times after the last bit of a received packet was presented by the MAU at its AUJ.

**11.3.4.8 Bit error ratio**

The MAU shall have a Bit Error Ratio (BER) as measured at the AUJ lower than one error in 10<sup>8</sup> in a “zero-length coax” test environment (that is, a coaxial cable connection sufficiently short to have negligible delay and transmission impairments). It shall have this BER for receive signal levels in the range specified in 11.3.1.1.3 and in the presence of –28.3 dBmV rms/14 MHz white Gaussian noise. This represents a 24.3 dB signal-to-noise ratio for the specified minimum signal level, –4 dBmV rms. For the same BER in a “system” environment (as opposed to zero-length coax), a 26 dB signal-to-noise ratio is required.

The MAU shall meet the BER requirements specified above when receiving strings of up to 33 consecutive identical bits.

**11.3.5 Reliability**

Component failures within the MAU electronics should not impede communication among other MAUs on the broadband coaxial cable. Connectors and other passive components comprising the means of connecting the MAU to the coaxial cable shall be designed to minimize the probability of total network failure. The MAU shall be designed to provide an MTBF of at least 1 000 000 hours without causing communication failure among other stations attached to the broadband local network medium.

## 11.4 System considerations

### 11.4.1 Delay budget and network diameter

The delay budget for the broadband MAU and rest of the Physical Layer is tabulated in Table 11–3. This table includes allocations for trunk cables (the backbone cables in the system), drop cables (a length of 25 m is assumed), etc. The velocities of propagation assumed are included in the table; use of other types of cables will alter the system diameter accordingly. The types of cables, including the mix of drop and trunk cable lengths, can be altered as long as the total propagation delay from the most distant MAU to the headend does not exceed 70 bit times. The total delay budget of 576 bit times includes allowance for the preamble and SFD (64 bits).

Table 11–3 tabulates delay allocations for a dual-cable system with no headend delay. In translated single-cable systems, the headend translator delay reduces the maximum trunk cable distance by  $[D/(2 \times CV)]$ , where  $D$  is the delay in nanoseconds, and  $CV$  is the cable velocity in nanoseconds per meter. For 3.83 ns/m velocity trunk cable, this reduction is  $[\text{Delay (ns)} / 7.66]$  m.

**Table 11–3—Broadband dual-cable systems—Physical Layer delay budget**

Delay element	Maximum allowed value (bits)
DTE1 starts to put out first bit	0.00
First bit from DTE1 at AUI	3.00
AUI cable (50 m at 5.13 ns/m)	2.57
Circuit DO to Tx RF out	24.00
Tx drop cable (25 m at 4.27 ns/m)	1.05
Tx trunk cable (1800 m at 3.83 ns/m)	68.95
Rx trunk cable (25 m at 4.27 ns/m)	68.95
Rx drop cable (25 m at 4.27 ns/m)	1.05
End of bit comparison (last bit of source address)	160.00
Rx RF to collision enforcement RF out (from RX bit that is found to be in error to collision enforcement out)	34.00
Tx drop cable (25 m at 4.27 ns/m)	1.05
Tx trunk cable (1800 m at 3.83 ns/m)	68.95
Rx trunk cable (1800 m at 3.83 ns/m)	68.95
Rx drop cable (25 m at 4.27 ns/m)	1.05
Rx collision enforcement to circuit Ci	31.00
AUI cable (50 m at 5.13 ns/m)	2.57
DTE1 detects collision presence	3.00
DTE1 jams channel	32.00
Allowance for traps, splitters, amplifiers, and margin	3.86
Total	576.00

### 11.4.2 MAU operation with packets shorter than 512 bits

The MAU transmits an SQE Test sequence onto the RF medium after every transmitted packet. If the frame plus preamble and SFD is less than the `ced_window` in length, a receiving MAU cannot distinguish the SQE

Test signal from a collision enforcement signal due to a collision. Therefore, operation of the MAU with data frames shorter than 512 bits may cause all other receiving MAUs to see a collision. The transmitting MAU, however, recognizes the SQE Test because that MAU was the one that transmitted the test. An MAU transmitting a short packet that encounters a collision can distinguish the resulting collision enforcement from an SQE Test signal by the fact that the transmitting MAU will not have transmitted the SQE Test sequence unless the packet is shorter than the round trip delay on the cable plant. In the latter instance, the transmitting MAU may not detect a collision enforcement.

## 11.5 Characteristics of the coaxial cable system

The cable system upon which the broadband MAU operates shall meet the following electrical and mechanical requirements.

### 11.5.1 Electrical requirements

The electrical requirements of the cable system are listed in Table 11–4. Each parameter is applicable over the frequency range to be used by the broadband MAU.

**Table 11–4—Cable system electrical requirements**

Impedance	75 $\Omega$
Return loss	14 dB min
Transmit level	+50 dBmV $\pm$ 2 dB
Receive level	+6 dBmV $\pm$ 10 dB
Maximum receive noise level	–30 dBmV/14 MHz
Loss variation <sup>a</sup> (per 18 MHz band)	2 dB min, 52 dB max
Path loss (between any transmit port and receive port, including loss variation)	36 dB min, 52 dB max
Group delay variation —around data carrier —over 18 MHz band	20 ns/10 MHz max 34 ns max

<sup>a</sup>Not including headend.

Adjacent channel signal levels shall be consistent with the requirements of 11.3.1.1.4.

### 11.5.2 Mechanical requirements

The connection of the cable system to the broadband MAU is via a standard F-series screw-on male connector. For the dual-cable case, two such connectors are required: one for transmit and the other for receive.

### 11.5.3 Delay requirements

The maximum length of the cable system is constrained by the allowable round trip delay from the farthest transmitting MAU to the farthest receiving MAU. Table 11–3 allows 140 bit times round trip delay in the cable system. For trunk cable propagation velocity of 3.83 ns/m, this allows 3600 m of trunk cable (round trip; 1800 m from the farthest point to the headend), and 25 m of 4.27 ns/m velocity drop cable at each MAU. In addition, 50 m of AUI cable is allowed on each MAU, therefore allowing, in this case, a maximum



of 3750 m DTE to DTE separation. These lengths will be different if cables of different propagation velocity are used. This is acceptable so long as the maximum delay is not exceeded.

For single-cable systems, the maximum delay of 140 bit times includes the delay through the headend. The maximum cable system length must be reduced appropriately, as described in 11.4.1.

## 11.6 Frequency translator requirements for the single-cable version

### 11.6.1 Electrical requirements

The headend frequency translator performance is included in the cable system characteristics specified in 11.5, except as defined in Table 11–5.

**Table 11–5—Frequency translator requirements**

Group delay variation —around data carrier frequency —between data carrier and CE center frequency	20 ns/10 MHz max 50 ns max
Amplitude variation (from 6 MHz below the input data carrier frequency to 1 MHz above the CE center frequency)	2 dB max
Translation frequency	per Table 11–1

The frequency translator contributes to total cable system delay and shall be labeled by the vendor with the input-to-output delay in the band of operation. The effect on network length can then be computed per 11.4.1.

### 11.6.2 Mechanical requirements

The input and output mechanical interface shall be 75  $\Omega$  female F-series coaxial connectors. The connection to the broadband medium shall be through a coaxial cable with a mating male F-series connector.

## 11.7 Environmental specifications

### 11.7.1 Safety requirements

This subclause sets forth a number of recommendations and guidelines related to safety concerns. This list is neither complete nor does it address all possible safety issues. The designer is urged to consult the relevant local, national, and international safety regulations to assure compliance with the appropriate standards.

LAN cable systems, as described in this clause, are subject to at least four direct electrical safety hazards during their use, and designers of connecting equipment should be aware of these hazards. The hazards are as follows:

- a) Direct contact between local network components and power or lighting circuits
- b) Static charge buildup on local network cables and components
- c) High-energy transients coupled onto the local network cabling system
- d) Potential differences between safety grounds to which various network components are connected

These electrical safety hazards, to which all similar cabling systems are subject, should be alleviated for a local network to perform properly. In addition to provisions for properly handling these faults in an operational system, special measures shall be taken to ensure that the intended safety features are not negated when attaching or detaching equipment from the LAN medium of an existing network.

Sound installation practice, as defined in applicable national and local codes and regulations, shall be followed in every instance in which such practice is applicable.

## **11.7.2 Electromagnetic environment**

### **11.7.2.1 Susceptibility levels**

Sources of interference from the environment include electromagnetic fields, electrostatic discharge, transient voltages between earth connections, etc.

The physical MAU hardware shall meet its specifications when operating in an ambient plane wave field of:

- a) 2 V/m from 10 kHz through 30 MHz
- b) 5 V/m from 30 MHz through 1 GHz

MAUs meeting this clause should provide adequate RF ground return to satisfy the EMC specification.

### **11.7.2.2 Emission levels**

The physical MAU hardware shall comply with the applicable national and local regulations for emission levels.

## **11.7.3 Temperature and humidity**

The MAU and associated cable system are expected to operate over a reasonable range of environmental conditions related to temperature, humidity, and physical handling such as shock and vibration. Specific requirements and values for these parameters are considered to be beyond the scope of this standard.

## 12. Physical signaling, medium attachment, and baseband medium specifications, type 1BASE5

NOTE—This MAU is not recommended for new installations. Since September 2003, maintenance changes are no longer being considered for this clause.

### 12.1 Introduction

#### 12.1.1 Overview

1BASE5 is a 1 Mb/s CSMA/CD network based on twisted-pair wiring. Each DTE (Data Terminal Equipment) is star-connected to a shared hub through two pairs that function as transmit and receive channels. Hubs can be cascaded, and DTEs can be connected to any hub. Packets transmitted by a DTE are propagated by the hub to a higher-level hub if one exists; otherwise the hub broadcasts the packet back down to all DTEs and lower-level hubs. Packets received by a hub from a higher-level hub are retransmitted to all attached DTEs and lower-level hubs. If two or more DTEs or lower-level hubs transmit concurrently, the hub generates a collision-presence signal that the DTEs detect as a collision. Hubs between a transmitting DTE and the header (highest level) hub propagate data or the collision-presence signal to the header hub; this hub in turn broadcasts the packet or collision signal to all DTEs and lower-level hubs.

#### 12.1.2 Scope

The 1BASE5 specification builds upon the first six major clauses of this standard; the remaining major clauses (other than this one, of course) do not apply to 1BASE5. That is, the Media Access Control (MAC) and Physical Signaling (PLS) Service Specifications are used in common with the other implementations of this standard, but the Physical Medium Attachment (PMA) sublayer, transmission medium, and hub functions for type 1BASE5 are specified in this clause. The relationship of the 1BASE5 specification to the OSI reference model and the IEEE 802.3 CSMA/CD LAN model is shown in Figure 12–1.

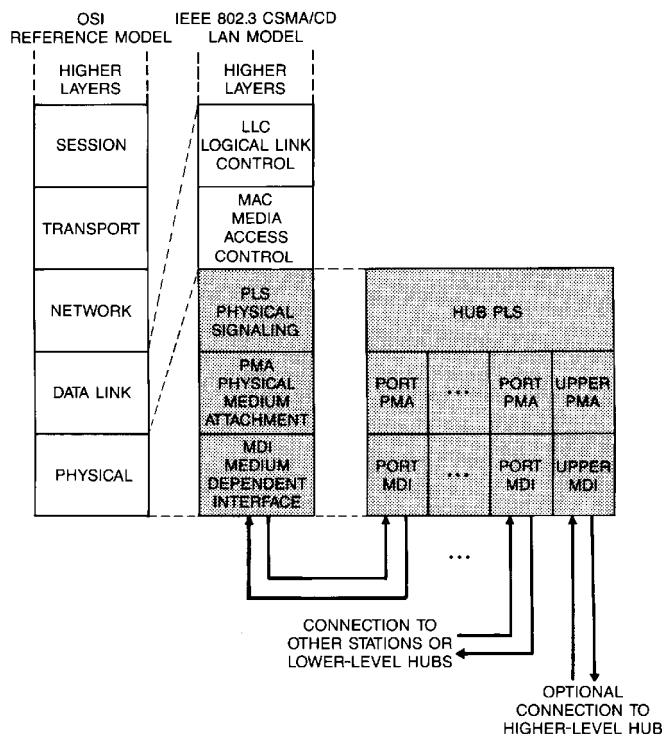
#### 12.1.3 Definitions

See 1.4.

#### 12.1.4 General characteristics

Type 1BASE5 has the following general characteristics:

- a) 1 Mb/s signaling rate, Manchester encoded
- b) Twisted-pair wiring
- c) Point-to-point interconnection of DTEs to hubs, with one twisted-pair serving as the upward link, the other as the downward link
- d) Data pairs can coexist in the same telephone cable bundles as voice pairs
- e) When a hub receives signals from a DTE or lower-level hub, it propagates them to a higher-level hub if one exists; otherwise, the hub broadcasts the signals back down to the DTEs and lower-level hubs
- f) When a hub receives signals concurrently from two or more DTEs or lower-level hubs, it generates a unique collision presence signal, and distributes it as in item e) above
- g) DTE-to-hub and hub-to-hub interfaces are electrically isolated at both ends
- h) Up to five hub levels are allowed
- i) Hubs serve as repeaters
- j) Maximum DTE-to-hub and hub-to-hub distance is approximately 250 m for telephone wiring (cable-type dependent; see 12.7)



**Figure 12–1—1BASE5 relationship to the ISO/IEC Open Systems Interconnection (OSI) reference model and the IEEE 802.3 CSMA/CD LAN model**

- k) Special links may be used to extend some DTE-to-hub or hub-to-hub distances to 4 km

### 12.1.5 Compatibility

This specification calls out one principal compatibility interface, namely PMA-to-Medium. It is intended that different implementations of DTEs and hubs be able to interoperate in 1BASE5 networks.

### 12.1.6 Objectives of type 1BASE5 specification

- a) Provide for low-cost networks, as related to both equipment and cabling
- b) Make it possible to use telephone-type building wiring, and in particular spare wiring when available
- c) Provide for easy installability, reconfigurability, and service
- d) Ensure interconnectability of independently developed DTEs and hubs
- e) Ensure fairness of DTE access
- f) Provide a communication channel with a resultant mean bit error ratio, at the physical layer service interface, of less than one part in  $10^8$  (on the order of one part in  $10^9$  at the link level)

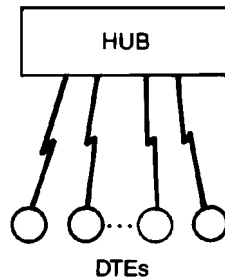
## 12.2 Architecture

### 12.2.1 Major concepts

Type 1BASE5 is a 1 Mb/s CSMA/CD network. DTEs are connected to hubs (and hubs to other hubs) by point-to-point wiring, resulting in a star topology network. Data transmissions are Manchester encoded.

An elementary configuration is illustrated in Figure 12–2. In this instance, each DTE is connected to the hub via separate transmit and receive channels (normally two twisted pairs). The hub serves as the point of concentration and performs two major functions: signal regeneration/retiming (repeating) and collision detection. When only one DTE transmits, the hub repeats the signals, compensating for amplitude and phase distortion, and broadcasts to all DTEs. When a hub detects two or more DTEs transmitting concurrently, the hub generates a unique Collision Presence (CP) signal, which it broadcasts instead of the originally transmitted signals. The hub continues to send CP until it receives IDL from all lower-level DTEs. CP has the property that it can be detected by DTEs as a Manchester code violation.

The interconnection architecture does not imply any minimum, typical, or maximum number of DTEs to be connected to a given hub; this is an implementation or installation detail.



**Figure 12–2—Single hub network**

Up to five levels of hubs may be cascaded. A two-level configuration is illustrated in Figure 12–3, with a header hub (HH) and intermediate hubs (IH). There can be a number of IHs; there must be one and only one HH. Each DTE or IH is connected to a hub via separate transmit and receive channels (normally two twisted pairs). An IH propagates signals from its DTEs toward the HH; it sends CP toward the HH in the event of a collision. The HH repeats the signals it receives from DTEs or IHs back down to all DTEs and IHs. The HH generates CP if more than one of its inputs becomes active. The IHs repeat the signals received from the HH, and broadcast to all the connected DTEs' receivers. Hubs do not distinguish whether input signals along the upward path emanate from DTEs or lower-level IHs. If a single input is active, the hub repeats the signal regardless of its source; if more than one is active, it generates CP.

A configuration involving four hub levels and a special link is illustrated in Figure 12–4. In this example, one IH is used for simple repeating (one connection upward and one connection downward). Other than having one link in and one link out, repeaters are identical to other hubs. Special links are connections, possibly containing active devices, that are used for situations requiring extra propagation delay or special transmission media.

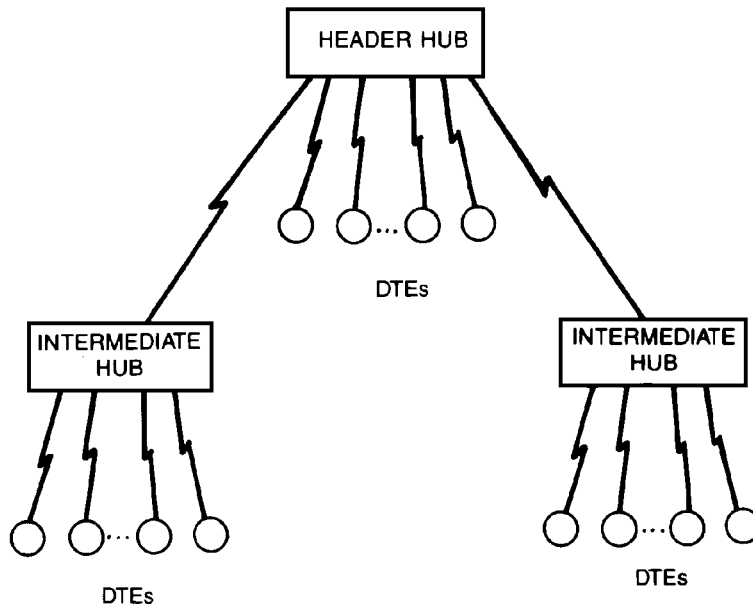
### 12.2.2 Application perspective

The primary application area for type 1BASE5 is expected to be in office environments for networking DTEs such as personal computers or other workstations. In many cases, spare wiring contained in existing telephone wire bundles will be used.

### 12.2.3 Packet structure

Packets are transmitted from the PLS to the PMA as follows:

<silence> <preamble> <sfd> <data> <etd> <silence>



**Figure 12-3—Network with two levels of hubs**

The packet elements shall have the following characteristics:

Element	Characteristics
<silence>	No transitions
<preamble>	Alternating CD1 and CD0 for $\geq 56$ bit times (ending in CD0)
<sfid>	CD1 CD0 CD1 CD0 CD1 CD0 CD1 CD1
<data>	$8 \times N$ instances of CD0 or CD1
<etd>	First part of IDL

### 12.2.3.1 Silence

The <silence> delimiter provides an observation window for an unspecified period of time during which no transitions occur. The minimum duration of <etd> followed by <silence> is the interFrameGap defined in 4.4.2.

### 12.2.3.2 Preamble

The <preamble> delimiter begins a packet transmission and provides a signal for receiver synchronization. The signal shall be an alternating pattern of CD1 and CD0. This pattern shall be transmitted by the DTE for a minimum of 56 bit times at the beginning of each packet. The last bit of the preamble (that is, the final bit of preamble before the start-of-frame delimiter) shall be a CD0.

The DTE is required to supply at least 56 bits of preamble in order to satisfy system requirements. System components consume preamble bits in order to perform their functions. The number of preamble bits sourced ensures an adequate number of bits are provided to each system component to correctly implement its function.

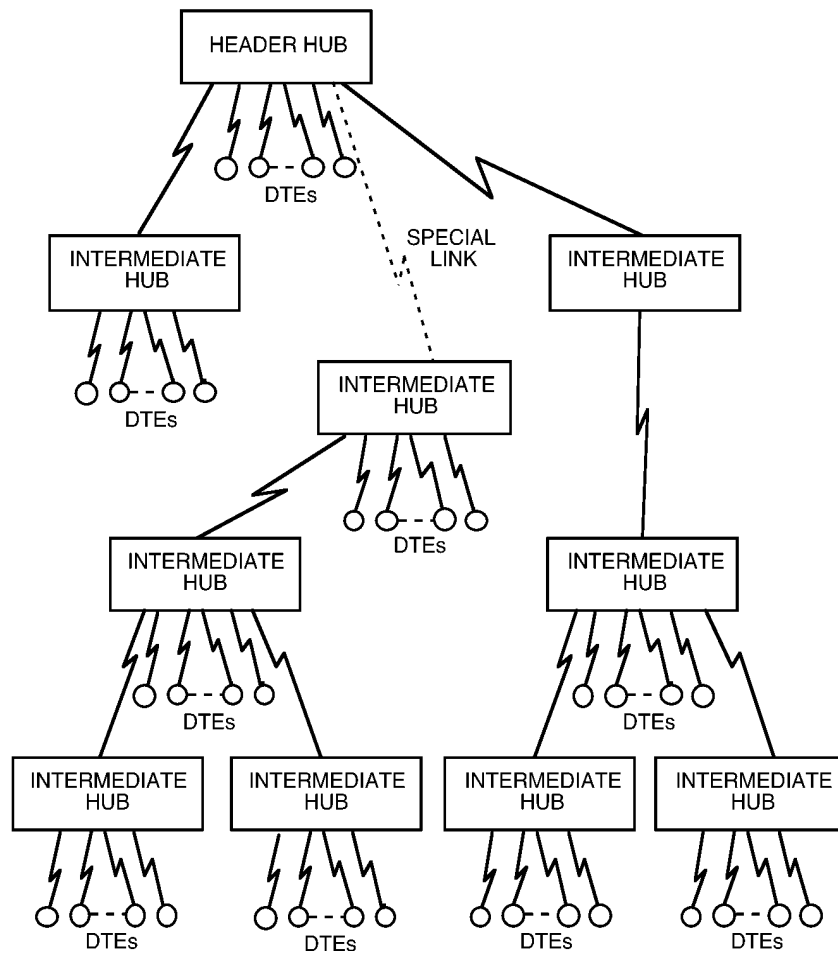


Figure 12-4—Network with four levels of hubs

### 12.2.3.3 Start-of-frame delimiter

The <sfid> indicates the start of a frame, and follows the preamble.

### 12.2.3.4 Data

The <data> in a transmission shall be in multiples of eight (8) encoded data bits (CD0s and CD1s).

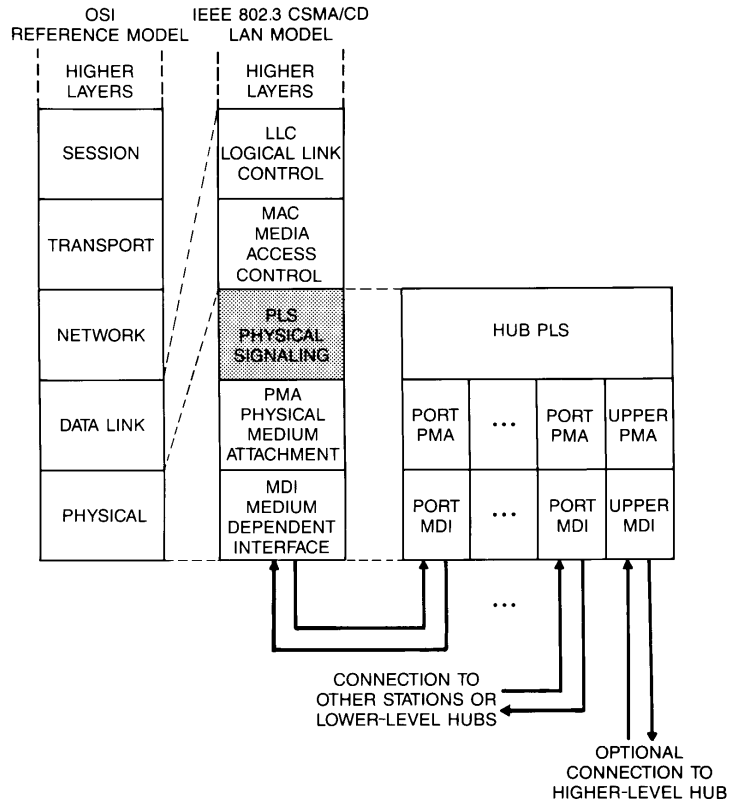
### 12.2.3.5 End-of-transmission delimiter

The <etd> indicates the end of a transmission and serves to turn off the transmitter. The signal shall be the first part of an IDL.

## 12.3 DTE physical signaling (PLS) specification

### 12.3.1 Overview

This subclause defines logical characteristics of the DTE PLS sublayer for IBASE5. The relationship of this specification to the entire standard is shown in Figure 12–5. The sublayer and its relationship to the MAC and PMA sublayers are described in an abstract way and do not imply any particular implementation.



**Figure 12–5—Station physical signaling, relationship to the ISO OSI reference model and the IEEE 802.3 CSMA/CD LAN model**

#### 12.3.1.1 Summary of major concepts

- a) There are two channels between the PLS and PMA sublayers. Output data are passed through the output channel and input data and control (CP) are passed through the input channel.
- b) Each direction of data transfer through the PLS operates independently and simultaneously (that is, the PLS is full duplex).

#### 12.3.1.2 Application perspective

The DTE PLS sublayer performs the following functions:

- a) Encodes OUTPUT\_UNITS from the MAC sublayer into a Manchester encoded waveform that it sends to the PMA sublayer output circuit
- b) Decodes a Manchester encoded waveform from the PMA sublayer input circuit into INPUT\_UNITS, CARRIER\_STATUS, and SIGNAL\_STATUS



### 12.3.2 Functional specification

This subclause provides a detailed model for the DTE PLS sublayer.

Many of the terms used in this subclause are specific to the interface between this sublayer and the MAC sublayer. These terms are defined in the service specification for the PLS sublayer (see 6.3).

#### 12.3.2.1 PLS-PMA interface

The PLS and PMA communicate by means of the following messages:

Message	Meaning	Source
<i>output</i>	Output information	PLS
<i>output_idle</i>	No data to be output	PLS
<i>input</i>	Input information	PMA
<i>input_idle</i>	No input information	PMA

##### 12.3.2.1.1 *output* message

The PLS sublayer sends an *output* message to the PMA sublayer when the PLS sublayer receives an OUTPUT\_UNIT from the MAC sublayer.

The physical realization of the *output* message is a CD0 or a CD1 sent by the PLS to the PMA. The PLS sends a CD0 if the OUTPUT\_UNIT is a ZERO or a CD1 if the OUTPUT\_UNIT is a ONE. This message is time-coded. That is, once this message has been sent, the function is not completed until one bit time later. The *output* message cannot be sent again until the bit cell being sent as a result of sending the previous *output* message is complete.

##### 12.3.2.1.2 *output\_idle* message

The PLS sublayer sends an *output\_idle* message to the PMA sublayer at all times when the MAC sublayer is not in the process of transferring output data across the MAC to PLS interface. The *output\_idle* message is no longer sent (and the first OUTPUT\_UNIT is sent using the *output* message) when the first OUTPUT\_UNIT of a packet is received from the MAC sublayer. The *output\_idle* message is again sent to the PMA when DATA\_COMPLETE is received from the MAC sublayer.

The physical realization of the *output\_idle* message is IDL sent by the PLS to the PMA.

##### 12.3.2.1.3 *input* message

The PMA sublayer sends an *input* message to the PLS sublayer when the PMA has received a bit from the medium and is prepared to transfer this bit to the PLS.

The physical realization of the *input* message consists of data units, CD0, CD1, CVL, or CVH, derived from the incoming data stream. If ambiguity exists due to excessive noise or jitter, the PMA may send an arbitrary combination of these.

##### 12.3.2.1.4 *input\_idle* message

The PMA sublayer sends an *input\_idle* message to the PLS sublayer when the PMA sublayer does not have data to send to the PLS sublayer. This condition exists when carrier is lost or IDL is received.

### 12.3.2.2 PLS-MAC interface

The PLS and MAC communicate by means of the following messages:

Message	Meaning	Source
OUTPUT_UNIT	Data sent to the PMA	MAC
OUTPUT_STATUS	Response to OUTPUT_UNIT	PLS
INPUT_UNIT	Data received from the PMA	PLS
CARRIER_STATUS	Indication of input activity	PLS
SIGNAL_STATUS	Indication of error/no error condition	PLS

#### 12.3.2.2.1 OUTPUT\_UNIT

The MAC sublayer sends the PLS sublayer an OUTPUT\_UNIT every time the MAC sublayer has a bit to send. Once the MAC sublayer has sent an OUTPUT\_UNIT to the PLS sublayer, it may not send another OUTPUT\_UNIT until it has received an OUTPUT\_STATUS message from the PLS sublayer. The OUTPUT\_UNIT is a ONE if the MAC sublayer wants the PLS sublayer to send a CD1 to the PMA sublayer, a ZERO if a CD0 is desired, or a DATA\_COMPLETE if an IDL is desired.

#### 12.3.2.2.2 OUTPUT\_STATUS

The PLS sublayer sends the MAC sublayer an OUTPUT\_STATUS in response to every OUTPUT\_UNIT received by the PLS sublayer. OUTPUT\_STATUS sent is an OUTPUT\_NEXT when the PLS sublayer is ready to accept the next OUTPUT\_UNIT from the MAC sublayer. (The purpose of OUTPUT\_STATUS is to synchronize the MAC sublayer data output with the data rate of the physical medium.)

#### 12.3.2.2.3 INPUT\_UNIT

The PLS sublayer sends the MAC sublayer an INPUT\_UNIT every time the PLS receives an *input* message from the PMA sublayer. The INPUT\_UNIT is a ONE if the PLS sublayer receives a CD1 from the PMA sublayer or a ZERO if the PLS sublayer receives a CD0 from the PMA sublayer. The INPUT\_UNIT may be either ZERO or ONE if the PLS sublayer receives a CVL or CVH from the PMA sublayer.

#### 12.3.2.2.4 CARRIER\_STATUS

The PLS sublayer sends the MAC sublayer CARRIER\_STATUS whenever there is a change in carrier status, as detected by the PMA. The PLS sublayer sends CARRIER\_ON when it receives an *input* message from the PMA and the previous CARRIER\_STATUS that the PLS sublayer sent to the MAC sublayer was CARRIER\_OFF. The PLS sublayer sends CARRIER\_OFF when it receives an *input\_idle* message from the PMA sublayer, and the previous CARRIER\_STATUS that the PLS sublayer sent to the MAC sublayer was CARRIER\_ON.

#### 12.3.2.2.5 SIGNAL\_STATUS

The PLS sublayer sends the MAC sublayer SIGNAL\_STATUS whenever it detects the beginning or end of Collision Presence. The PLS sublayer sends SIGNAL\_ERROR when it receives *input* message CVL or CVH from the PMA sublayer and the previous SIGNAL\_STATUS the PLS sublayer sent was NO\_SIGNAL\_ERROR. The PLS sublayer sends NO\_SIGNAL\_ERROR when it receives an *input\_idle* message from the PMA sublayer and the previous SIGNAL\_STATUS that the PLS sent to the MAC sublayer was SIGNAL\_ERROR. The PLS shall send SIGNAL\_ERROR to the MAC sublayer when the

Collision Presence pattern is detected; it may send SIGNAL\_ERROR any time it receives an *input* message that is neither CD0 nor CD1.

### 12.3.2.3 PLS functions

The PLS sublayer functions consist of four simultaneous and asynchronous functions. These functions are Output, Input, Error Sense, and Carrier Sense. All of the four functions are started immediately following PowerOn. These functions are depicted in the state diagrams shown in Figure 12–6 through Figure 12–9, using the notation described in 1.2.1.

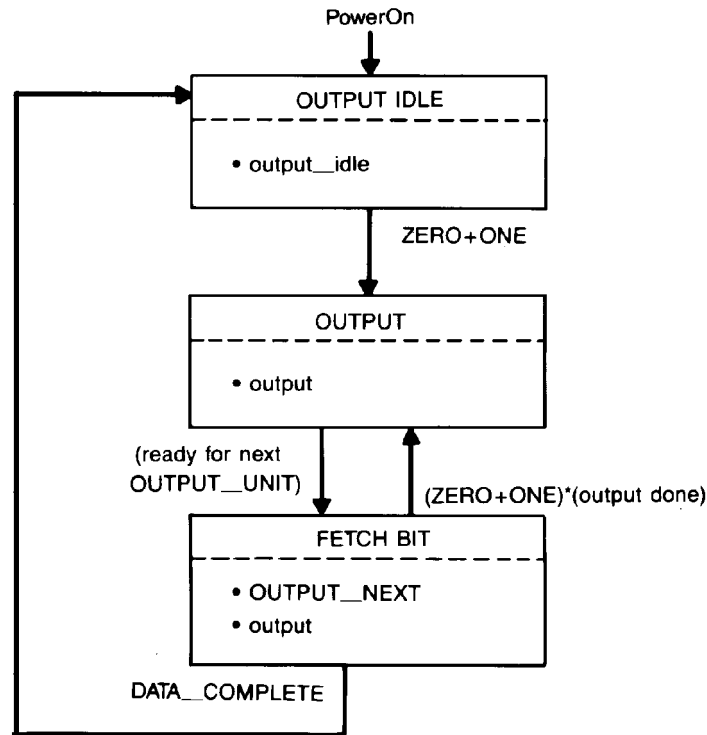


Figure 12–6—DTE PLS Output function

#### 12.3.2.3.1 State diagram variables

The variables used in the state diagrams and the corresponding descriptions are the following:

a) *Inter Process Flags*

*disable\_SIGNAL\_ERROR* Used in the state diagrams and functions. It is used by the Input function to prevent false collision detection by the Error Sense function during preamble startup.

*protectTimer* Used by the Carrier Sense function to implement the protection period described in 12.5.3.2.3. It is started by “start-protectTimer.” “protectTimer\_done” is satisfied when the timer has expired.

#### 12.3.2.3.2 Output function

The Output function transparently performs the task of data transfer from the MAC sublayer to the PMA sublayer. The state diagram of Figure 12–6 depicts the Output function operation.

### 12.3.2.3.3 Input function

The Input function transparently performs the task of data transfer from the PMA sublayer to the MAC sublayer. The state diagram of Figure 12–7 depicts the Input function operation.

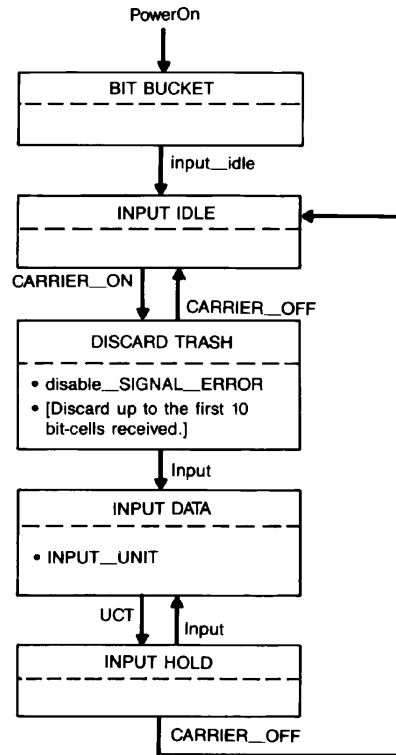


Figure 12–7—DTE PLS Input function

### 12.3.2.3.4 Error Sense function

The Error Sense function performs the task of sending `SIGNAL_STATUS` to the MAC sublayer at the beginning and end of the Collision Presence pattern. The state diagram of Figure 12–8 depicts the Error Sense function operation.

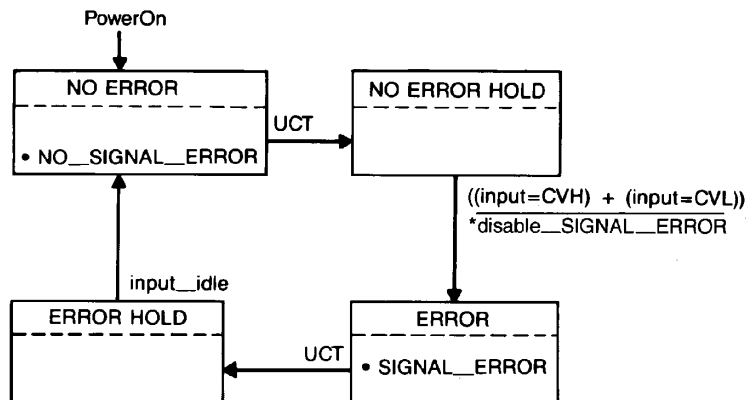


Figure 12–8—DTE PLS Error Sense function

### 12.3.2.3.5 Carrier Sense function

The Carrier Sense function performs the task of sending CARRIER\_STATUS to the MAC sublayer whenever the input becomes active or idle, as detected by the PMA sublayer. The state diagram of Figure 12–9 depicts the Carrier Sense function operation.

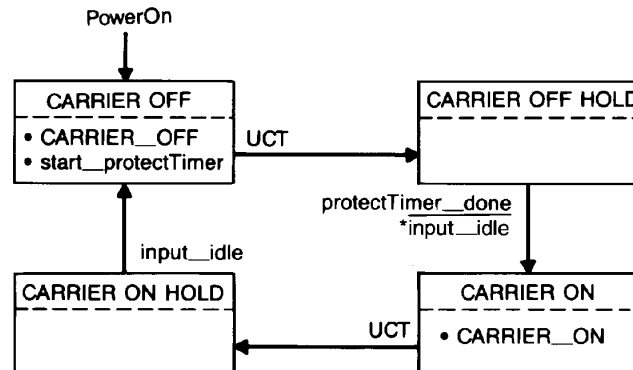


Figure 12–9—DTE PLS Carrier Sense function

A timer may be used by the Carrier Sense function to implement the protection period described in 12.5.3.2.3. It is started by “start-protectTimer” and asserts “protectTimer\_done” after 0 to 30  $\mu$ s since starting.

### 12.3.2.4 Signal encoding

Five distinct symbols can be transmitted on the line: CD0, CD1, CVL, CVH, and IDL. Of these, CVL and CVH are transmitted only as part of the collision presence reporting pattern CP.

#### 12.3.2.4.1 Data transmission rate

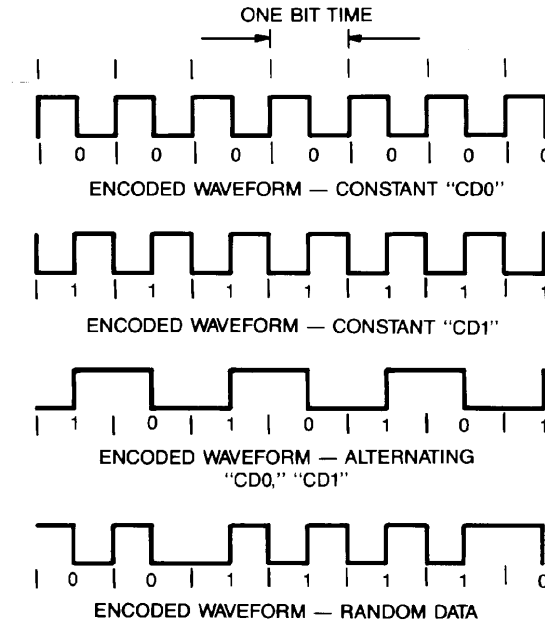
The data transmission rate (BR) is 1 Mb/s  $\pm$  0.01%. A bit time (BT) is therefore nominally 1  $\mu$ s.

#### 12.3.2.4.2 Data symbol encoding

Manchester encoding is used for the transmission of packets. Manchester encoding is a binary signaling mechanism that combines data and clock into bit cells. Each bit cell is split into two halves with the second half containing the binary inverse of the first half; a transition always occurs in the middle of each bit cell. During the first half of the bit cell, the encoded signal is the logical complement of the bit value being encoded. During the second half of the bit cell, the encoded signal is the uncomplemented value of the bit being encoded. Thus, a CD0 is encoded as a bit cell in which the first half is HI and the second half is LO. A CD1 is encoded as a bit cell in which the first half is LO and the second half is HI. Examples of Manchester waveforms are shown in Figure 12–10. The zero crossings of an ideal Manchester waveform occur on precise half-bit-cell boundaries. The zero crossings of real waveforms may include timing jitter that causes deviation from these “idealized zero crossings.”

#### 12.3.2.4.3 Collision presence encoding

Two signals, CVL and CVH, that are transmitted only as part of the collision presence reporting pattern, CP, violate the normal Manchester encoding rule requiring a transition in the middle of each symbol. A CVH is encoded as a transition from LO to HI at the beginning of the bit cell, HI for the entire bit cell, and transition



**Figure 12-10—Examples of Manchester waveforms**

from HI to LO at the end of the bit cell. A CVL is encoded as a transition from HI to LO at the beginning of the bit cell, LO for the entire bit cell, and transition from LO to HI at the end of the bit cell.

The Collision Presence reporting signal, CP, is a special sequence that differs from any legitimate Manchester-encoded signal. CP is encoded as a repeating sequence of 1 bit time LO, 1/2 bit time HI, 1 bit time LO, 1 bit time HI, 1/2 bit time LO, and 1 bit time HI. This may also be interpreted as repetitions of the five-symbol sequence CVL, CD0, CD1, CD0, CVH. Should a transmitter's or receiver's timing be shifted by 1/2 bit time, then the same sequence will be interpretable as repetitions of CD1, CVL, CVH, CD1, CD0. In either case, the presence of non-Manchester symbols distinguishes the sequence from data. Examples of Collision Presence waveforms are shown in Figure 12-11. See 12.3.2.2.5 and 12.4.3.2 for further details on the detection and generation of CP.

NOTE—CP is the minimal length sequence that meets the following design criteria:

- a) The sequence should not look like legitimate Manchester-encoded data even if the receiver does not lock onto the correct bit-cell boundaries.
- b) The sequence should maintain overall dc balance. That is, it should be HI 50% of the time and LO the other 50%.
- c) The signal should occupy the same part of the frequency spectrum as normal data. That is, transitions should occur every half or whole bit time so that the fundamental signaling frequencies of  $BR/2$  and  $BR$  are maintained. Furthermore, allowing more than one bit time to pass without a transition would introduce ambiguity with the idle line condition (IDL).

#### 12.3.2.4.4 Idle line encoding

The line condition IDL is also used as an encoded signal. An IDL always starts with a HI signal level. Since IDL always starts with a HI signal, an additional transition will be added to the data stream if the last bit sent was a zero. This transition cannot be confused with clocked data (CD0 or CD1) since the transition will occur at the start of a bit cell. There will be no transition in the middle of the bit cell. The HI signal level, as sent by a transmitter, shall be maintained for a minimum of 2 bit times.

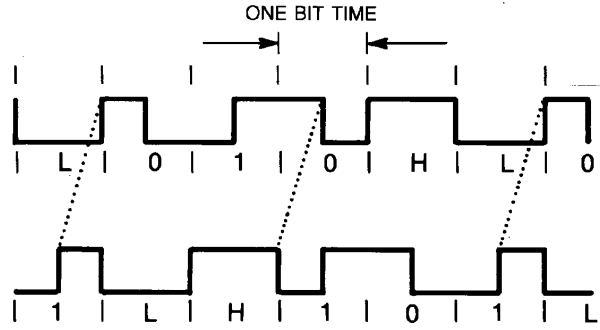


Figure 12-11—Examples of collision presence waveforms

## 12.4 Hub specification

### 12.4.1 Overview

This subclause defines the logical characteristics of the hub used in 1BASE5. The relationship of this specification to the entire standard is shown in Figure 12-12.

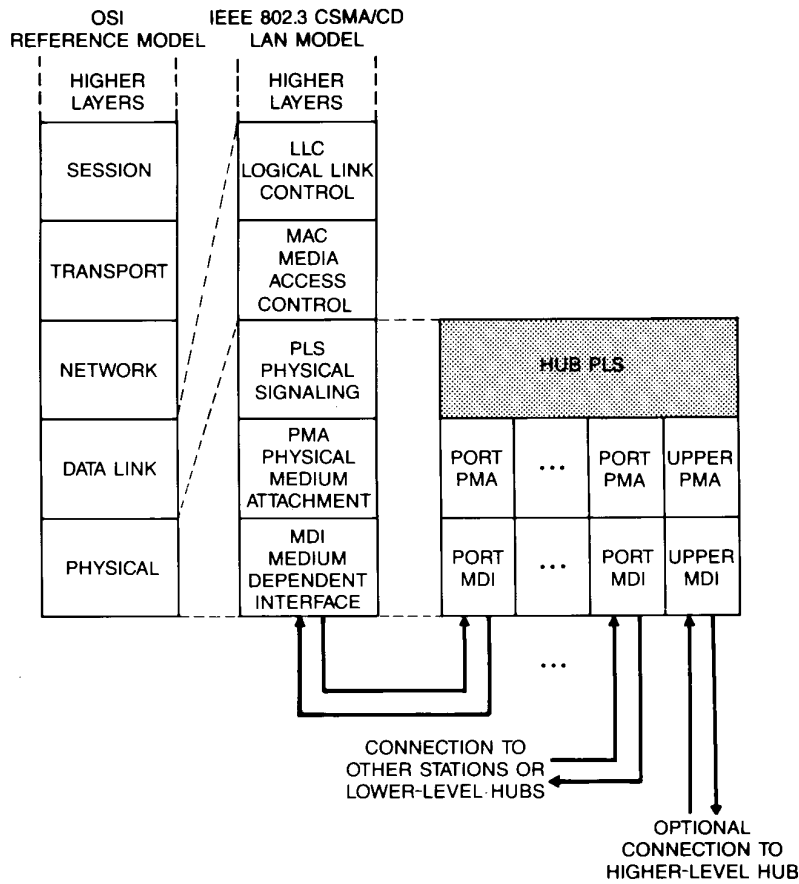


Figure 12-12—Hub relationship to the OSI reference model and the IEEE 802.3 CSMA/CD LAN model

#### 12.4.1.1 Summary of major concepts

- a) A hub consists of a Hub PLS sublayer and a number of instances of the PMA sublayer.
- b) One instance of the PMA sublayer, the “upper PMA,” provides a connection to a higher-level hub. This PMA is not required for the header hub.
- c) Each of the remaining instances of the PMA sublayer, called “port PMAs,” provides a connection to a DTE or a lower-level hub.
- d) The Hub PLS transfers data in two directions: upward from the port PMAs, to the upper PMA and downward from the upper PMA to the port PMAs.
- e) The upward and downward “sides” of the hub operate independently and simultaneously.

#### 12.4.1.2 Application perspective

The hub is a physical layer entity that performs two functions:

- a) It retransmits incoming signals with amplitude and timing restored.
- b) It detects collisions between any two or more ports and reports knowledge of the collision by transmitting a special collision presence reporting pattern.

#### 12.4.2 Hub structure

Each hub is functionally divided into two parts: the upward side and the downward side. The upward side is responsible for combining the transmissions from DTEs and hubs lower in the network into a single transmission to the next level up. The downward side is responsible for distributing the combined signal (which is wrapped around from the upward side of the header hub) to each of the DTEs and hubs below. Except as specified in 12.4.3.2.3 and 12.4.3.2.6, the two sides function independently.

There is an upward input channel and a corresponding downward output channel for each DTE or hub immediately below the hub. Although there is no electrical connection between the two lines, they do share a connector and cable (see 12.6 and 12.7) and are collectively known as a hub port. Each port is accessed through an instance of the PMA sublayer referred to as a “port PMA.”

The one output channel from the upward side and the one input channel to the downward side of a hub are similarly paired and, for all but the header hub, are connected to a port of the next-higher-level hub. They are accessed through an instance of the PMA sublayer referred to as the “upper PMA.”

NOTE—A hub that includes  $n$  hub ports should be called an  $n$ -port hub, even though it may have an extra jack for the upper PMA. The latter connection should never be counted as a port, despite common engineering usage, because it does not meet the specific definition of a 1BASE5 hub port given above.

##### 12.4.2.1 Upward side

The primary function of the upward side of a hub is to propagate signals from each of its inputs to its single output. If more than one input is active, then the Collision Presence signal CP is transmitted instead. In addition, the signals are retimed to restore the transitions to half-bit-time boundaries; see 12.4.3.2.5 for the details of retiming.

##### 12.4.2.2 Downward side

The primary function of the downward side of a hub is to repeat signals from its one input to each of its outputs. In addition, the signals are retimed to restore the transitions to half-bit-time boundaries; see 12.4.3.2.5 for the details of retiming.



### 12.4.3 Hub PLS functional specification

This subclause provides a detailed model for the Hub PLS sublayer.

#### 12.4.3.1 Hub PLS to PMA interface

The interface between the Hub PLS and the PMA is the same as that specified in 12.3.2.1 for use between the DTE PLS and the PMA except that the *output* message from the Hub PLS to the PMA is used to transmit CVL and CVH in addition to CD0 and CD1.

#### 12.4.3.2 Hub PLS functions

The Hub PLS sublayer functions consist of three asynchronous functions. These functions are Upward Transfer, Jabber, and Downward Transfer. All three functions are started immediately following PowerOn; an independent copy of the Jabber function is started for each port PMA. These functions are depicted in the state diagrams shown in Figure 12–13 through Figure 12–15, using the notation described in 1.2.1.

##### 12.4.3.2.1 State diagram variables

The variables used in the state diagrams and the corresponding descriptions are the following:

- a) *Port designators*: Instances of the PMA sublayer are referred to by index. PMA information is obtained by replacing the X in the desired function with the index of the PMA of interest. Furthermore, PMAs may be referenced by several special designators used as indices:

X Generic port PMA designator. When X is used in a state diagram its value indicates the particular instance of a generic function.

UPPER Indicates the upper PMA.

ALLPORTS Indicates that all port PMAs are to be considered. All port PMAs must meet a test condition in order for that test to pass.

ALLENABLEDPORTS Indicates that all port PMAs that are not disabled by the Jabber function are to be considered. All such port PMAs must meet a test condition in order for that test to pass.

ONEPORT Indicates that all port PMAs that are not disabled by the Jabber function are to be considered. One, but not more than one, such port PMA must meet a test condition in order for that test to pass.

>ONEPORT Indicates that all port PMAs that are not disabled by the Jabber function are to be considered. Two or more such port PMAs must meet a test condition in order for that test to pass.

N Defined by the PORT function on exiting from the UPWARD IDLE state of Figure 12–13. It indicates which port PMA caused the exit from the UPWARD IDLE state.

- b) *Port functions*:

PORT(TestCondition) Returns the index of a port PMA passing the indicated test condition. If multiple port PMAs meet the test condition, the PORT function will return one and only one of the acceptable values.

- c) *Input variables*:

INPUT(X) Indicates the state of activity on the designated PMA input channel. It may be either “idle” or “active.” The former indicates that *input\_idle* is asserted; the latter indicates that it is not asserted.

input(X) Used to receive an *input* message (see 12.3.2.1) from the designated PMA input channel.

probation\_alternative Used to distinguish between the two allowed alternatives for exiting the JABBER JAM state of Figure 12–14 when an active port becomes idle. The implementor of a hub may treat the variable as either true or false.

d) *Output variables:*

output(X) Used to send an *output* message (see 12.3.2.1 and 12.4.3.1) to the designated PMA output channel.

output\_idle(X) Used to send an *output\_idle* message (see 12.3.2.1) on the designated PMA output channel.

e) *Inter process flags:*

send\_collision Used by the Upward Signal Transfer function to indicate a series of *output* messages to the upper PMA sublayer, the effect of which is to transmit the CP signal, as described in 12.3.2.4.2, 12.3.2.4.3, and 12.4.3.2.7.

jabber\_collision Used by the various instances of the Jabber function to signal the Upward Signal Transfer function that CP should be generated.

disable\_input(X) Used to disable the designated PMA input channel. The input is re-enabled when disable\_input(X) is no longer asserted. Only the Upward Signal Transfer function is affected by the disabling of a port (via the ALLENABLEDPORTS, ONEPORT, and >ONEPORT designators).

jabberTime1 Used by the Jabber function (see 12.4.3.2.3) to detect excessively long transmissions. It is started by “start\_jabberTime1.” “jabberTime1\_done” is satisfied when the timer has expired.

jabberTime2 Used by the Jabber function (see 12.4.3.2.3) to determine when to disable ports due to excessively long transmissions. It is started by “start\_jabberTime2.” “jabberTime2\_done” is satisfied when the timer has expired.

#### 12.4.3.2.2 Upward Signal Transfer function

The Upward Signal Transfer function combines signals from the various port inputs and passes them on to the upper output. It also detects and reports collisions as appropriate. The state diagram of Figure 12–13 depicts its operation.

Signals are propagated upward according to the following rules, except as controlled by the Jabber function (see 12.4.3.2.3):

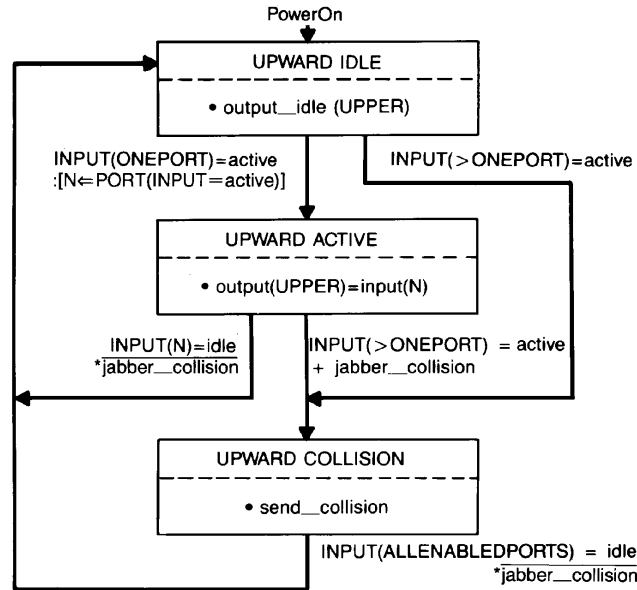
- a) If IDL is present on all port inputs, then transmit IDL.
- b) If IDL is present on all but one of the port inputs, then repeat the signal received from that one line. If that one signal is CP, then a hub may generate its own CP signal instead of repeating the received CP signal.
- c) If two or more inputs are active (non-IDL) at the same time, then transmit CP and continue transmitting CP until all inputs indicate IDL again.

Whenever the hub finishes transmitting CP, it shall then transmit IDL, including the extended HI period.

#### 12.4.3.2.3 Jabber function

The Jabber function detects abnormally long transmissions and takes appropriate action to abort them. The state diagram of Figure 12–14 depicts its operation.

Two timers are used by the Jabber function. They may be implemented either as local timers for each instance of the Jabber function or as global timers shared by all instances. Furthermore, because the two timers are always started concurrently, an implementation may share circuitry between the two.



**Figure 12–13—Hub PLS Upward Transfer function**

The first timer is started by “start\_jabberTime1” and asserts “jabberTime1\_done” after 25 to 50 ms since starting. If implemented as a single global timer, assertion of start\_jabberTime1 by any instance of the Jabber function with any other instance(s) still waiting for that timer shall not restart the timer, thereby shortening the waiting period for the latest instance.

Similarly, the second timer is started by “start\_jabberTime2” and asserts “jabberTime2\_done” after 51 to 100 ms since starting. If implemented as a single global timer, assertion of start\_jabberTime2 by any instance of the Jabber function with any other instance(s) still waiting for that timer shall not restart the timer, thereby shortening the waiting period for the latest instance. Furthermore, if this second timer is implemented as a single global timer, then assertion of start\_jabberTime1 by any instance of the Jabber function with any other instance(s) still waiting for just the second timer (in the JABBER JAM state) shall be treated as if the first timer expires immediately (asserting jabberTime1\_done) for the latest instance, thereby causing that instance to join the other instance(s) waiting for the second timer.

Hardware within the upward side of a hub shall provide a window of 25 to 50 ms, during which time a normal packet or CP sequence may be propagated upward. If any port input (or, as an alternative implementation, the hub’s combined upward signal) exceeds this duration without becoming idle, then the hub shall switch to transmitting CP until 51 to 100 ms after the beginning of the window and then, if that input is still active, disable that input (or all nonidle inputs) until it once again becomes active while the downward side is idle.

The “probatation\_alternative” input variable is used to distinguish between the two allowed alternatives for exiting the JABBER JAM state of Figure 12–14 when an active port becomes idle. The implementor of a hub may treat the variable as either true or false. If true, the port will enter the JABBER PROBATION state (via the JABBER SHUTOFF state); if false, the port will instead return to the JABBER IDLE state.

#### 12.4.3.2.4 Downward Signal Transfer function

The Downward Signal Transfer function repeats signals from the upper input to the various port outputs. The state diagram of Figure 12–15 depicts its operation.

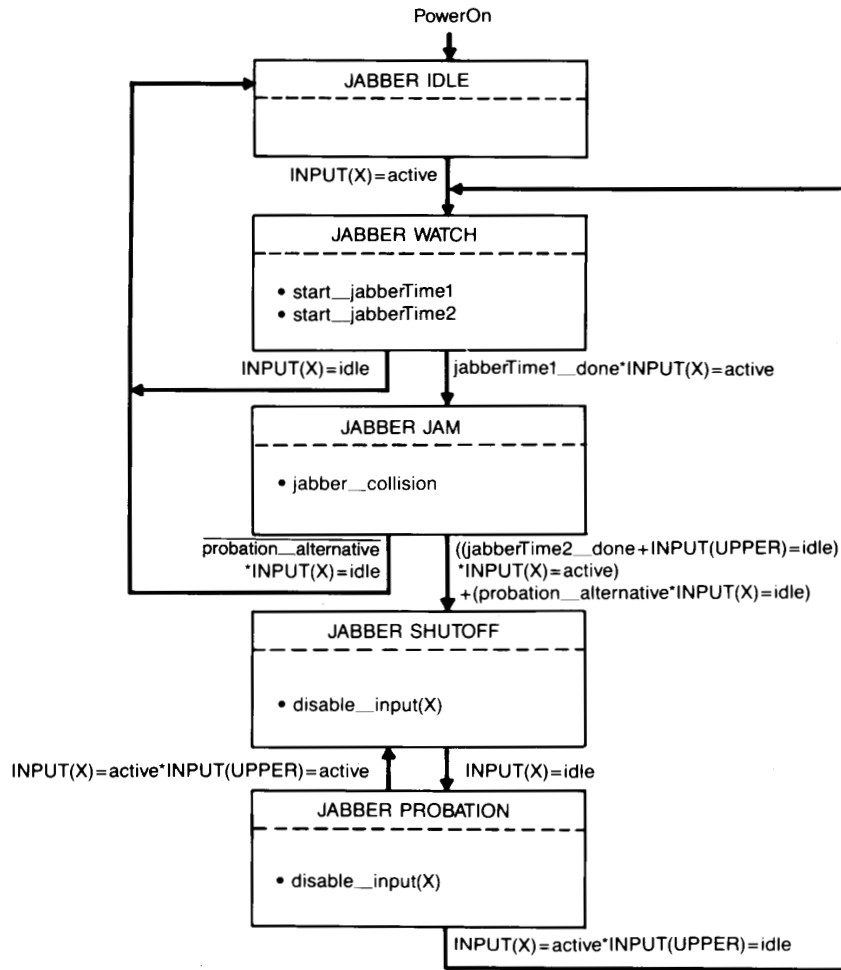


Figure 12–14—Hub PLS Jabber function for port X

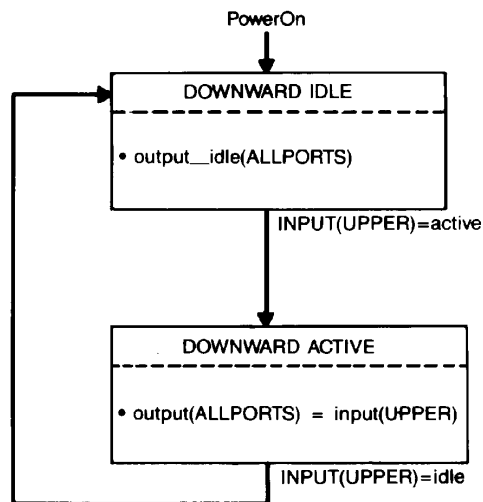


Figure 12–15—Hub PLS Downward Transfer function

The downward side of a hub may detect the Collision Presence signal at the upper input and generate its own CP signal to be transmitted at the port outputs (in place of repeating the received CP signal).

Whenever the hub finishes transmitting CP, it shall then transmit IDL, including the extended HI period.

#### **12.4.3.2.5 Retiming (jitter removal)**

Each side of each hub shall retime any clocked signals that it propagates so that the transitions occur on half-bit-time boundaries, thereby avoiding accumulation of excessive jitter. Such retiming shall preserve the sequence of CD0, CD1, CVL, and CVH symbols being propagated.

If an ambiguity exists in the incoming bit cells due to excessive noise or jitter, than the appropriate side of the hub may either switch to generating CP or replace the erroneous bit cell with an arbitrary combination of half or whole bit cells.

Retiming also accounts for differences (if any) in clock rates between that used to send bit cells to the hub and that used to send them out from the hub. Excessive differences in clock rates (caused by clocks not meeting 12.3.2.4.1) and excessively long packets (caused by exceeding maxFrameSize) may each cause the capacity of the retiming function to be exceeded. In such circumstances, the appropriate side of the hub may either switch to transmitting CP or add or delete half or whole bit cells as needed.

Whenever bit cells are added, deleted, or replaced, the hub shall maintain synchronization of the outgoing bit cells to a half or whole bit cell boundary. Furthermore, it shall not generate periods of more than one bit time without a transition.

#### **12.4.3.2.6 Header hub wrap-around**

For each particular network configuration, one hub operates as the header hub and all others as intermediate hubs. It is suggested, but not required, that hub implementations be capable of being used for either purpose. Methods for switching between these two modes are beyond the scope of this standard.

For an intermediate hub, the upper output shall be connected to a port input of the next higher-level hub and the upper input shall be connected to a port output of a higher-level hub.

For the header hub, the upper output shall be connected to the upper input. This wraparound may appropriately bypass parts of the PMA specification so long as the resulting implementation is functionally equivalent to one with a wired connection. For example, signals internal to the hub need not be translated to the corresponding external levels and then translated back to internal levels. Similarly, it shall not be necessary to retime the wrapped signal twice, once in the upward side and then again in the downward side of the same header hub; a single retiming is permissible.

#### **12.4.3.2.7 Collision presence startup**

When a hub starts generating CP (as specified in 12.4.3.2.2 through 12.4.3.2.5) it shall synchronize the startup to a half or whole bit-cell boundary of any immediately preceding signal. If it was sending IDL immediately before the CP, no synchronization or preamble is required.

A hub may start transmission of CP at any point in the sequence that does not result in periods of more than one bit time without a transition during the switch from passing on data to sending CP. Depending on the preceding signal, it may start with L010H, 010HL, 10HL0, 0HL01, or HL010. Because startup may be synchronized to any half-bit-cell boundary, a hub may also transmit the shifted version of CP starting with 1LH10, LH101, H101L, 101LH, or 01LH1.

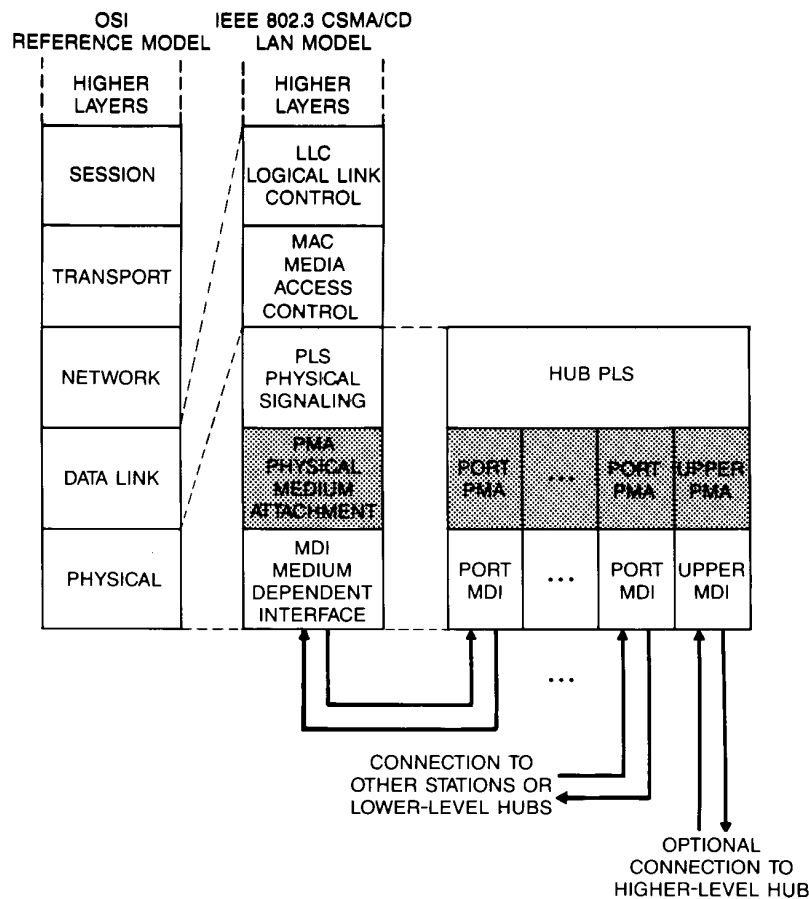
### 12.4.3.3 Reliability

Hubs shall be designed to provide a mean time between failure (MTBF) of at least 45 000 hours of operation. Hubs, including the associated connectors and other passive components, should be designed to minimize the probability that, a particular failure results in total network failure. Furthermore, the port electronics of each hub should be designed so as to minimize the probability that the failure of one port prevents communication by equipment attached to the other ports.

## 12.5 Physical medium attachment (PMA) specification

### 12.5.1 Overview

This subclause defines the Physical Medium Attachment (PMA) sublayer for 1BASE5. The relationship of this specification to the entire International Standard is shown in Figure 12–16. The PMA sublayer connects the PLS sublayer to the Medium Dependent Interface (MDI).



**Figure 12–16—Physical medium attachment, relationship to the OSI reference model and the IEEE 802.3 CSMA/CD LAN model**

### 12.5.2 PLS–PMA interface

The interface between the PLS and the PMA sublayers is specified in 12.3.2.1 for DTEs and in 12.4.3.1 for hubs.

### 12.5.3 Signal characteristics

#### 12.5.3.1 Transmitter characteristics

Transmitters should operate properly when loaded with any cable meeting the requirements of 12.7. To approximate the boundary conditions of such loading, two specific test loads are specified. Transmitters shall meet all requirements of this subclause when connected to both the “light” (115  $\Omega$ ) load shown in Figure 12–17 and the “heavy” (approximately 80  $\Omega$ ) load shown in Figure 12–18. It is expected that transmitters that perform correctly with these two loads will also perform acceptably under intermediate loading conditions.

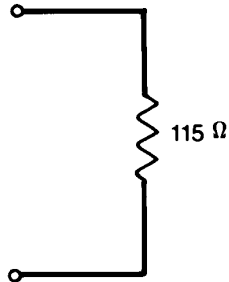


Figure 12–17—Simulated light load

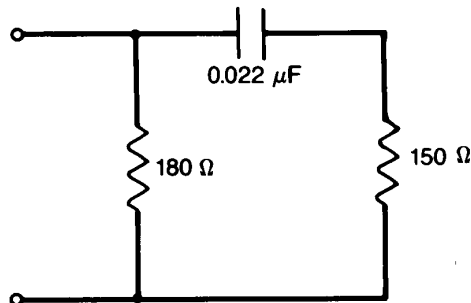


Figure 12–18—Simulated heavy load

##### 12.5.3.1.1 Differential output voltage

For simplicity of explanation, the text and figures of this subclause describe the differential output voltage in terms of voltage magnitudes. The requirements of this subclause apply to the negative pulses as well as the positive ones.

Beginning with the second bit of the preamble (or CP, if no preamble is present), pulses of duration  $BT/2$  shall meet the conditions of Figure 12–19. Pulses of duration  $BT$  shall meet the conditions of Figure 12–20. After the zero-crossing, the output shall exceed the voltage of a signal rising from the zero-crossing to 2.0 V with a slope of magnitude 20 mV/ns. The output shall remain above 2.0 V until 100 ns before the next, zero-crossing. The peak output voltage shall not exceed 3.65 V. While falling from 2.0 V to the zero-crossing, the signal shall exceed the voltage of a signal falling from 2.0 V to the zero-crossing with a slope of magnitude 20 mV/ns.

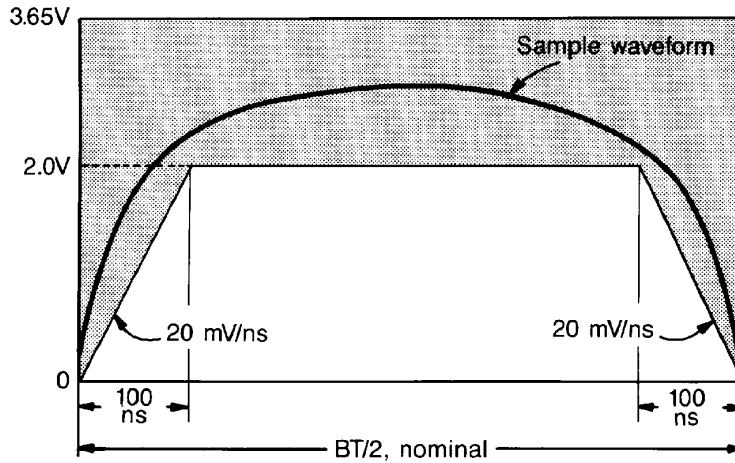


Figure 12-19—Differential output voltage, nominal duration  $BT/2$

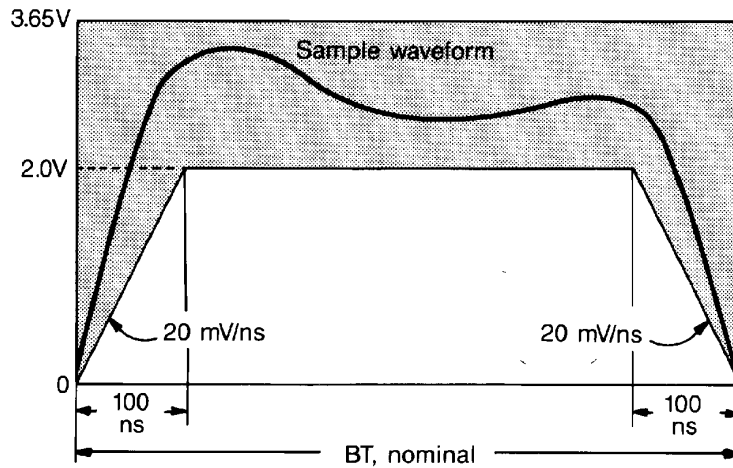


Figure 12-20—Differential output voltage, duration  $BT$

For pulses of duration  $BT$ , the average voltage that appears from 100 ns after the zero-crossing through  $BT/2$  shall be between 0.95 and 1.8 times the average voltage that appears from time  $BT/2$  through 100 ns before the following zero-crossing. Similarly, for pulses of duration  $BT$ , the peak voltage that appears from 100 ns after the zero-crossing through  $BT/2$  shall be between 0.95 and 1.8 times the peak voltage that appears from time  $BT/2$  through 100 ns before the following zero-crossing.

NOTE—The purpose of the above restrictions on average and peak voltages is to avoid transmitter waveforms that peak excessively during the second half of signals of duration  $BT$ , resulting in excessive jitter at the receiver. Some equalization to produce slight droop in the second half of signals of duration  $BT$ , on the other hand, may help decrease jitter at the far end of long cables.

The amplitude of the power spectrum at the output of the transmitter for all possible sequences of signals shall not exceed that produced by an idealized transmitter sending corresponding rectangular waveforms with magnitude 3.65 V at any frequency.

When a transmitter enters the idle state, it shall maintain a minimum differential output, voltage of 2.0 V from 100 ns through 2  $BT$  after the last low-to high transition, as illustrated in Figure 12-21. The differential



output voltage shall then fall to 1.1 V within 3 BT after that same low-to-high transition. Starting when the differential output voltage first reaches 1.1 V, the magnitude of the output voltage driven into the test loads indicated in Figure 12–22 and Figure 12–23 shall then remain within the limits indicated in Figure 12–21 until the transmitter leaves the idle state.

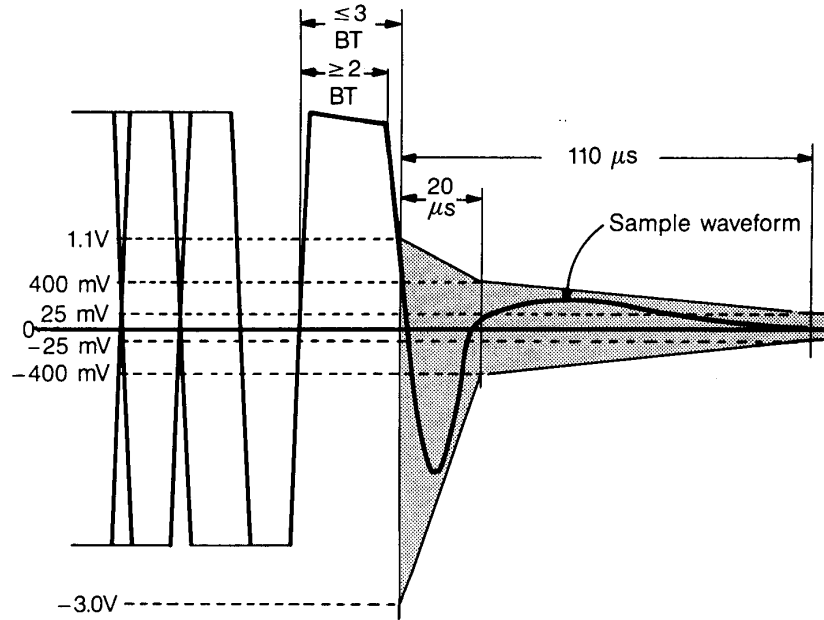


Figure 12–21—Transmitter waveform for idle

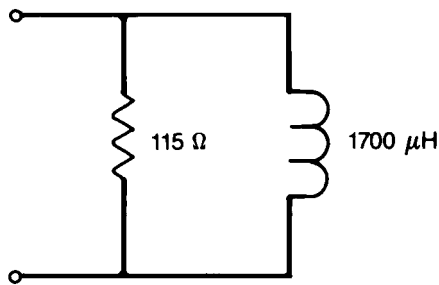


Figure 12–22—Start-of-idle test load #1

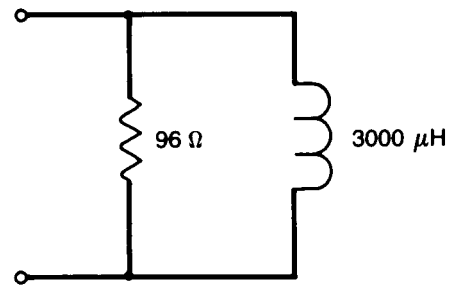


Figure 12–23—Start-of-idle test load #2

The transmitter output at the start of idle may exhibit overshoot, ringing, slow voltage decay, or a combination thereof due to the following factors:

- a) Change in transmitter source impedance between the active and idle states
- b) Difference in the magnitudes of the differential output voltage between the high and low output states ( $\Delta V_{OD}$ )
- c) Waveform asymmetry at the transmitter ( $\Delta T$ )
- d) Transmitter and receiver (transformer) inductance ( $L$ )

NOTE 1—The contribution to the undershoot from each of these can be computed with the following equations:

$$V_{\Delta V_{OD}} = \pm V_{OD} \times (R_{OFF} / 2R_N)$$

$$V_{\Delta T} = (\pm \Delta T / 1000 \text{ ns}) \times V_P (R_{OFF} / R_{ON})$$

$$V_L = V_P \times (1 - e^{-2.75 \mu s / (L_P / R_{ON})}) \times (R_{OFF} / R_{ON})$$

where

$$R_{OFF} = (R_{SRC-OFF} \parallel R_L)$$

$$R_{ON} = (R_{SRC-ON} \parallel R_L)$$

$R_{SRC-OFF}$  = source impedance ( $\Omega$ ) when the driver is off

$R_{SRC-ON}$  = source impedance ( $\Omega$ ) when the driver is on

$R_L$  = load impedance ( $\Omega$ )

$L_P$  = combined inductance ( $\mu\text{H}$ ) of the transmitter and receiver transformers

$\Delta V_{OD}$  = the difference (V) in magnitude of the HI and LO output voltages

$\Delta T$  = asymmetry of the waveform equals the difference between the average HI and average LO pulse widths (ns) at the transmitter

$VP$  = the maximum output voltage (V) during the start of IDL

NOTE 2—The waveform shown in Figure 12–21 and the equations in the preceding note apply to a transmitter connected to the test loads of Figure 12–22 and Figure 12–23. An actual receiver may present a more complex termination impedance and so the undershoot or overshoot may exceed that encountered with the test loads.

### 12.5.3.1.2 Output timing jitter

The transmitted signal zero-crossings shall deviate from the idealized zero-crossings by no more than  $\pm 10$  ns.

### 12.5.3.1.3 Transmitter impedance balance

The longitudinal to metallic impedance balance of the transmitter, defined as  $20 \log_{10}(E_{\text{test}}/E_{\text{dif}})$ , where  $E_{\text{test}}$  is an externally applied ac voltage, as shown in Figure 12–24, shall exceed 44 dB at all frequencies up to and including 4BR in the idle and nonidle states.

NOTE—It may be difficult to measure the transmitter impedance balance in the nonidle state. A frequency-selective wavemeter or other measurement technique may be required. Furthermore, the balance of the test equipment (such as the matching of the 400  $\Omega$  resistors) must exceed that required of the transmitter.

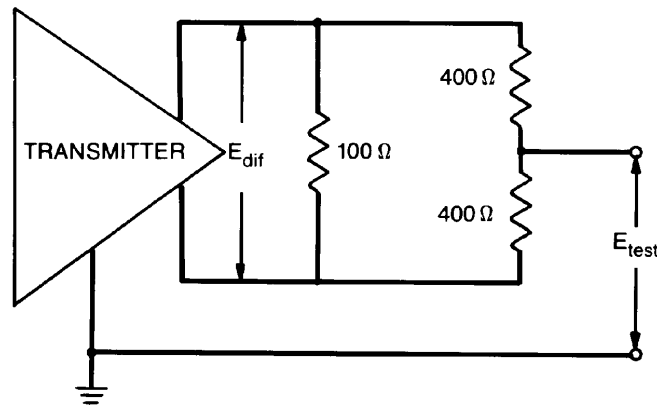


Figure 12–24—Transmitter impedance balance

### 12.5.3.1.4 Common-mode output voltage

The magnitude of the total common-mode output voltage of the transmitter,  $E_{cm}$ , measured as shown in Figure 12–25, shall not exceed 300 mV.

NOTE—The implementor should consider any applicable local, national, or international regulations and standards concerning RF emission. Driving unshielded twisted pairs with high-frequency common-mode voltages may result in interference to other equipment.

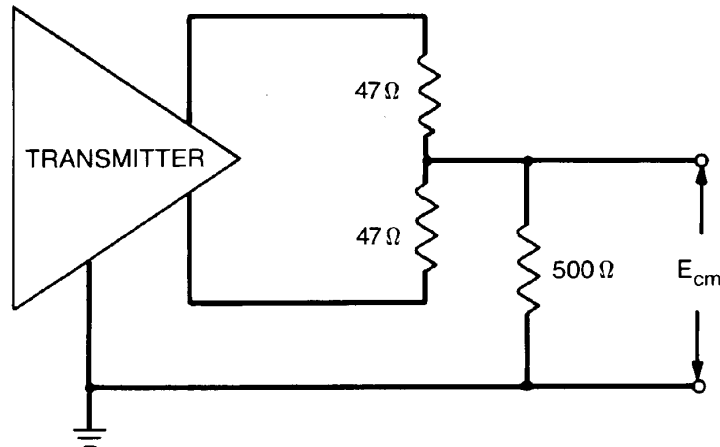


Figure 12–25—Common-mode output voltage

### 12.5.3.1.5 Common-mode tolerance

Transmitters shall meet the requirements of 12.5.3.1.1 and 12.5.3.1.2 even in the presence of common-mode sinusoidal voltage,  $E_{cm}$  (as shown in Figure 12–26), of  $\pm 20$  V peak at frequencies from 40 kHz through 6BR.

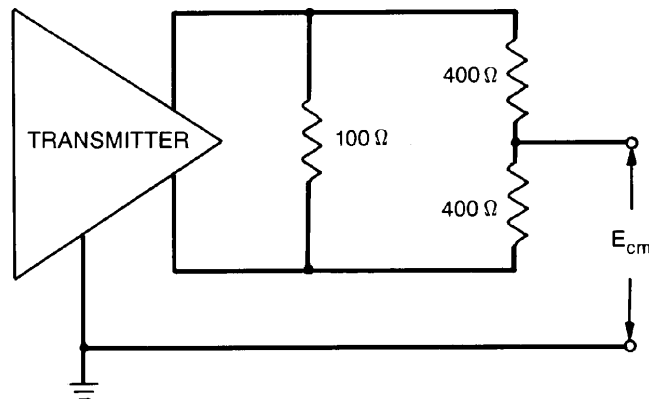


Figure 12–26—Transmitter common-mode tolerance

### 12.5.3.1.6 Transmitter fault tolerance

Transmitters, both when idle and when nonidle, shall tolerate the application of short circuits across their outputs for an indefinite period of time without damage and shall resume normal operation after such faults are removed. The magnitude of the current through such a short circuit shall not exceed 300 mA.

Transmitters, both when idle and when nonidle, shall withstand, without damage, a 1000 V common-mode impulse of either polarity, applied as indicated in Figure 12–27. The shape of the impulse shall be 0.3/50  $\mu$ s (300 ns virtual front time, 50  $\mu$ s virtual time of half value), as defined in IEC 60060.

NOTE—Tolerance of, and recovery from, the application of the telephony voltages described in 12.10.2 is optional, but the safety requirements of that subclause are mandatory.

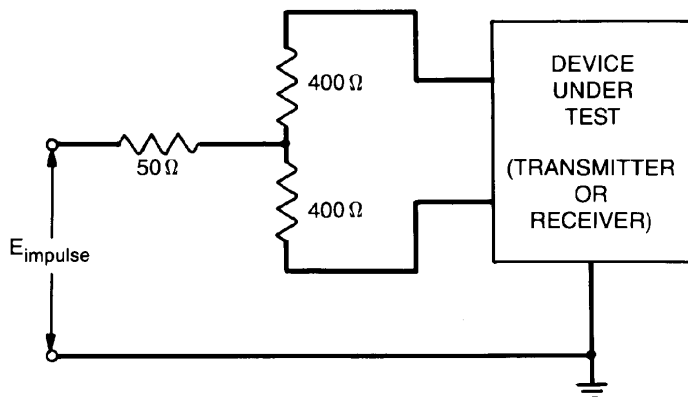


Figure 12–27—Common-mode impulse test

### 12.5.3.2 Receiver characteristics

#### 12.5.3.2.1 Differential input voltage

The receiver shall operate properly when a signal meeting the minimum magnitude requirements of Figure 12–28 is received. When less than 300 mV, the magnitude of the voltage will exceed that of a straight line through the nearest zero-crossing with slope of magnitude 9 mV/ns. That is, the average slew rate near each zero-crossing will exceed 9 mV/ns. The magnitude of the voltage will also remain at or above 1.0 V for some period lasting at least 150 ns (650 ns for pulses of duration BT) that starts within 250 ns of the preceding zero-crossing and its peak will be at least 1.1 V.

#### 12.5.3.2.2 Input timing jitter

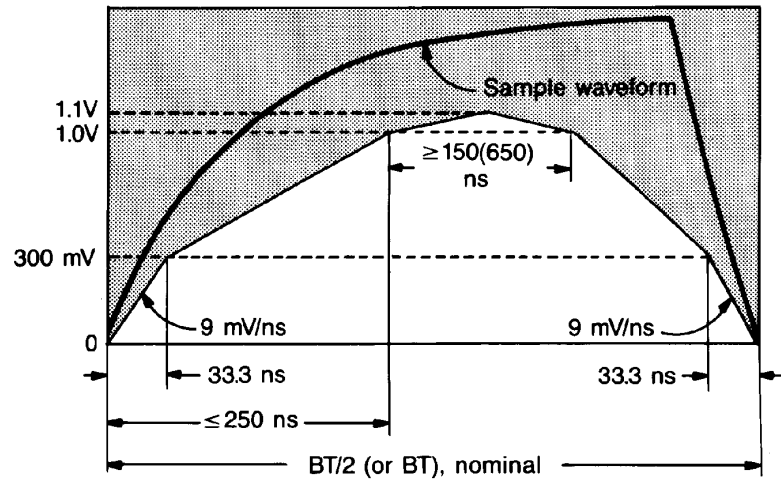
Receivers shall operate properly with zero-crossing jitter of up to  $\pm 32$  ns from the ideal.

#### 12.5.3.2.3 Idle input behavior

The IDL condition shall be detected within 1.8 bit times of the last low-to-high transition at the receiver.

NOTE 1—It is necessary to distinguish CVH from IDL.

NOTE 2—System jitter considerations make it impractical to detect IDL (<etd>, end-of-transmission delimiter) any sooner than 1.3 bit times. The specific implementation of the clock recovery mechanism, or equivalent, determines the lower bound on the actual IDL detection time. Adequate margin should be provided between the lower bound and 1.8 bit times.



**Figure 12-28—Receiver signal envelope**

The receiver shall take precautions to ensure that the HI-to-silence transition of the start of IDL is not falsely interpreted as a silence-to-nonidle transition, even in the presence of signal droop, overshoot, ringing, slow voltage decay, or a combination thereof due to capacitive and inductive effects in the transmitter, cable, and receiver, including those discussed in 12.5.3.1.1.

To this end, a receiver in a hub shall treat its input as if it were idle for between 20 and 30  $\mu\text{s}$  after detecting IDL. The timing of this “protection” period for the port PMAs may use a single timer that is started when all ports have become idle or disabled by the Jabber function. Receivers in DTEs may include a similar protection period of up to 30  $\mu\text{s}$ .

NOTE—The protection period is required in hubs because erroneously interpreting the start-of-idle as a new transmission will result in propagation of the error to DTEs, despite any precautions taken in those DTEs. The protection period is optional in DTEs because any implementation error in a DTE will affect only that particular DTE.

#### 12.5.3.2.4 Differential input impedance

The (complex) differential input impedance of the receiver,  $Z_{\text{receiver}}$ , shall be such that the reflection attenuation, defined as  $20 \log_{10} (|Z_{\text{receiver}} + Z_{\text{cable}}| / |Z_{\text{receiver}} - Z_{\text{cable}}|)$ , where  $Z_{\text{cable}}$  is the differential characteristic impedance of the attached cable, exceeds 16 dB over the range  $BR/2$  through  $2BR$  for all cables meeting the requirements of 12.7.2.

#### 12.5.3.2.5 Common-mode rejection

Receivers shall assume the proper output state for any differential input signal,  $E_s$ , that results in a signal,  $E_{\text{dif}}$ , that meets 12.5.3.2.1 and 12.5.3.2.2, even in the presence of common-mode sinusoidal voltages,  $E_{\text{cm}}$  (as shown in Figure 12-29), of  $\pm 20$  V peak at frequencies from 40 kHz through 6BR.

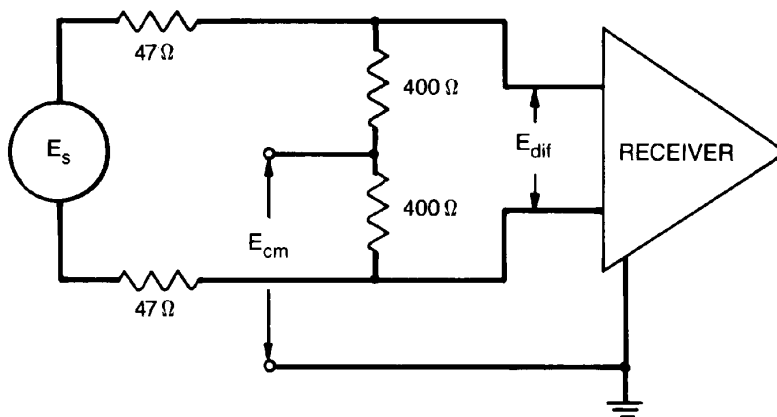


Figure 12-29—Receiver common-mode rejection

### 12.5.3.2.6 Noise immunity

Receivers shall meet the following limits on average error ratios when the noise described in 12.7.4 is added to the signals described in 12.5.3.2.1 and 12.5.3.2.2:

- a) When nonidle, the receiver error ratio shall not exceed one error in  $10^8$  bits.
- b) When idle, a receiver used in a DTE shall not falsely detect carrier more than one in 100 s.
- c) When idle, a receiver used in a hub shall not falsely detect carrier more than once in 1500 s.

NOTE—Receivers whose inputs include a 2–4 MHz, 2-pole, low-pass, Butterworth filter and a 560 mV squelch level will meet this last requirement for idle-mode noise immunity yet still perform properly with the weakest signal allowed by 12.5.3.2.1.

### 12.5.3.2.7 Receiver fault tolerance

Receivers shall tolerate the application of short circuits across their inputs for an indefinite period of time without damage and shall resume normal operation after such faults are removed.

Receivers shall withstand, without damage, a 1000 V common-mode impulse of either polarity, applied as indicated in Figure 12-27. The shape of the impulse shall be 0.3/50  $\mu$ s (300 ns virtual front time, 50  $\mu$ s virtual time of half value), as defined in IEC 60060.

NOTE—Tolerance of, and recovery from, the application of the telephony voltages described in 12.10.2 is optional, but the safety requirements of that subclause are mandatory.

## 12.6 Medium Dependent Interface (MDI) specification

### 12.6.1 Line interface connector

8-pin connectors meeting the requirements of Clause 3 and Figure 1 through Figure 5 of IEC 60603-7 shall be used as the compatibility interface between the PMA and the medium. The use of other types of connectors, if any, within a PMA or within the medium, although not explicitly prohibited, is outside the scope of this standard.

### 12.6.2 Connector contact assignments

The contacts of the connectors, as depicted in Figure 12–32 and Figure 12–31, shall correspond to signaling circuits as indicated below:

Contact	Signal
1	Upward Data+ (positive for HI signal)
2	Upward Data– (negative for HI signal)
3	Downward Data+ (positive for HI signal)
4	not used by 1BASE5
5	not used by 1BASE5
6	Downward Data– (negative for HI signal)
7	reserved
8	reserved

For DTEs and the upper MDI of hubs, contacts 1 and 2 are used for transmitting and contacts 3 and 6 are used for receiving. For the port MDIs of hubs, however, contacts 1 and 2 are used for receiving and contacts 3 and 6 are used for transmitting.

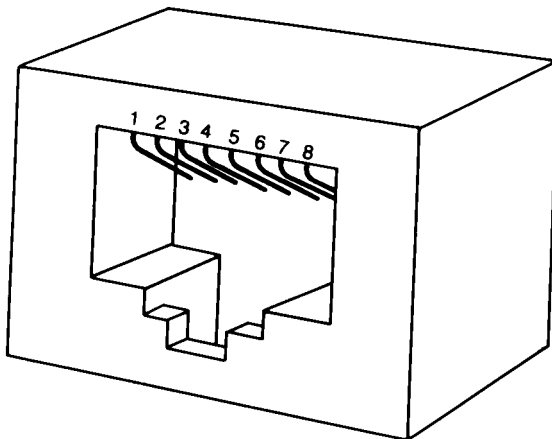


Figure 12–30—DTE and hub connector

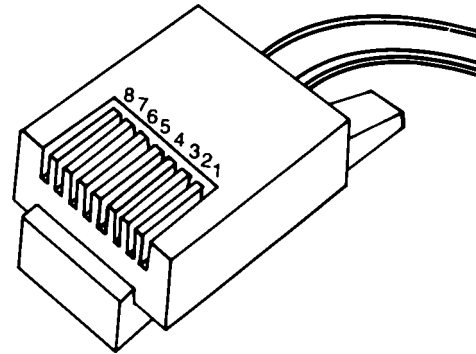


Figure 12–31—Cable connector

### 12.6.3 Labeling

To distinguish 1BASE5 connectors from those used for other purposes, it is recommended that appropriate labels be affixed to wall outlets and other connectors. This is particularly important in environments in which the specified 8-contact connectors are used for more than one purpose.

## 12.7 Cable medium characteristics

### 12.7.1 Overview

A significant number of IBASE5 networks are expected to utilize in-place building wiring. In this environment, DTEs connect to wall outlets using twisted-pair telephone cord. The wall outlets, in turn, connect to wiring closets, where hubs could be located, using standard telephone wiring. This wiring typically consists of 0.4–0.6 mm diameter (26–22 gauge) unshielded twisted pairs.

### 12.7.2 Transmission parameters

Each wire pair used to interconnect DTEs and hubs shall meet the requirements of 12.9.3 and also have the following characteristics.

#### 12.7.2.1 Attenuation

Total cable attenuation between a transmitter and the corresponding receiver shall be no more than 6.5 dB at all frequencies between BR/2 and BR, 9.2 dB at frequencies between BR and 2BR, and 13.8 dB at frequencies between 2BR and 4BR.

#### 12.7.2.2 Differential characteristic impedance

The magnitude of the differential characteristic impedance at frequency BR,  $Z_{BR}$ , of each wire pair used shall be between 80  $\Omega$  and 115  $\Omega$ . In addition, the magnitude and phase angle of the characteristic impedance at each of the following frequencies shall be within the corresponding ranges indicated:

Frequency	Magnitude		Phase angle	
	Minimum	Maximum	Minimum	Maximum
BR/4	$Z_{BR}$	$Z_{BR} + 7 \Omega$	$-10^\circ$	$0^\circ$
BR/2	$Z_{BR}$	$Z_{BR} + 5 \Omega$	$-8^\circ$	$0^\circ$
BR	$Z_{BR}$	$Z_{BR}$	$-6^\circ$	$0^\circ$
2BR	$Z_{BR} - 4 \Omega$	$Z_{BR}$	$-4^\circ$	$0^\circ$
4BR	$Z_{BR} - 5 \Omega$	$Z_{BR}$	$-3^\circ$	$0^\circ$

#### 12.7.2.3 Medium timing jitter

Intersymbol interference and reflections due to impedance mismatches between the sections of a cable segment can introduce jitter in the timing of the zero-crossings. A cable segment terminated in 96  $\Omega$  shall add no more than  $\pm 17$  ns, referenced to the transmit clock, of edge jitter when driven with a rectangular signal of magnitude 2.5 V through a source impedance 22  $\Omega$ . The driving signal shall be a Manchester-encoded pseudo-random sequence of data with a repetition period of at least 511 bits.

NOTE 1—The reflections caused by splicing two cable sections that have different characteristic impedances (but that each meet the requirements of 12.7.2.2) will not contribute significantly to timing jitter if the splice is within 10 m of either end of the segment.

NOTE 2—Branches off a wire pair (often referred to as “bridged taps” or “stubs”) will generally cause excessive jitter and so should be avoided.

NOTE 3—Jitter can be measured at the receiving end of a segment using an oscilloscope. The oscilloscope is triggered



on zero-crossings; the deviation of subsequent zero-crossings from multiples of  $BT/2$  is then observed. The deviation of each zero-crossing must not exceed  $\pm 34$  ns.

#### 12.7.2.4 Dispersion

Each wire pair shall produce an output signal that meets the zero-crossing edge rate described in 12.5.3.2.1 when driven with a 1 MHz trapezoidal signal of magnitude 2.0 V (that is, 4.0 V peak-to-peak) with edge rate 20 mV/ns.

#### 12.7.3 Coupling parameters

To avoid excessive coupling of signals between pairs of a cable, the crosstalk and imbalance must be limited.

Crosstalk attenuation is specified with the far end of both the disturbed and the disturbing pairs and the near end of the disturbed pair terminated in  $96 \Omega$ .

##### 12.7.3.1 Pair-to-pair crosstalk

The near-end, differential, crosstalk attenuation between each wire pair and each other pair in the same cable shall be at least 45 dB frequencies up to BR and at least  $45 - 15 \log_{10}(f/BR)$  dB for each frequency  $f$  between BR and 4BR.

##### 12.7.3.2 Multiple-disturber crosstalk

The near-end, differential, crosstalk attenuation between multiple disturbing wire pairs and a disturbed pair in the same cable shall be at least 38.5 dB at frequency BR and at least  $38.5 - 15 \log_{10}(f/BR)$  dB for each frequency  $f$  between BR and 4BR.

When two or more disturbers are present in a common cable sheath, the multiple-disturber, near-end, crosstalk attenuation (MDNEXT) into each pair, measured in dB, may be determined using the following equations:

$$H_j = \sum_{i \neq j} 10^{(-X_{ij}/20)} \cos \theta_{ij}$$

$$V_j = \sum_{i \neq j} 10^{(-X_{ij}/20)} \sin \theta_{ij}$$

$$MDNEXT_j = 10 \log_{10}(H_j^2 + V_j^2)$$

where

- $i$  iterates over each disturbing pair
- $j$  is the disturbed pair
- $X_{ij}$  is the magnitude of the near-end, differential, crosstalk attenuation from pair  $i$  to pair  $j$
- $\theta_{ij}$  is the phase angle of the near-end, differential, crosstalk attenuation from pair  $i$  to pair  $j$

If only the probability distribution of  $X_{ij}$  is known, then the distribution of MDNEXT can be determined using Monte Carlo methods with that  $X_{ij}$  distribution and a phase angle uniformly distributed between 0 and  $2\pi$  rad.

NOTE—See B.3 for example computations of MDNEXT distributions.

### 12.7.3.3 Balance

The longitudinal to metallic balance of the cable, defined as  $20 \log_{10} (E_{\text{test}} / 2E_x)$ , where  $E_{\text{test}}$  is an externally applied voltage, as shown in Figure 12–32, shall exceed 44 dB at all frequencies up to 4BR.

NOTE—The balance of the test equipment (such as the balance of the transformer and the matching of the 300 Ω resistors) must exceed that required of the cable.

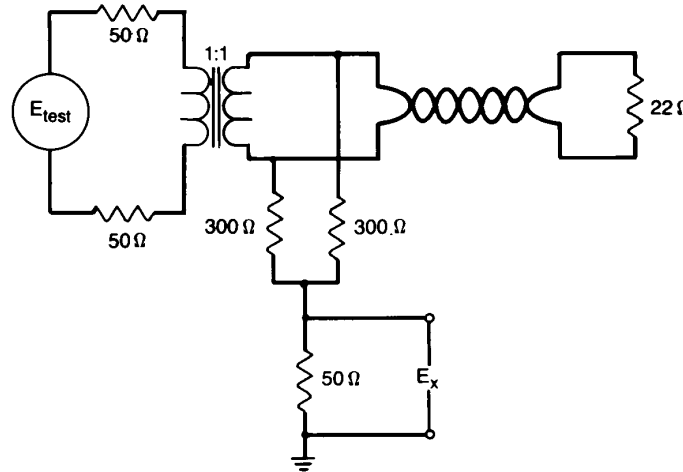


Figure 12–32—Cable balance test

### 12.7.4 Noise environment

Links used with 1BASE5 shall provide a noise environment no worse than that described below. The total noise environment generally results from two primary contributions: self-crosstalk from other 1BASE5 wire pairs and externally induced impulse noise, typically from telephone ringing and dialing signals, and office machinery. For the purposes of this standard, it can be assumed that the two components contribute independently and so the total error rate can be appropriately split between the two.

#### 12.7.4.1 Impulse noise

The noise voltage on wire pairs terminated at both ends in 96 Ω, as measured through the following specified filters, shall not exceed the corresponding threshold voltages more than 9 times per 1800 s interval. Following the start of any particular impulse that is counted, any additional impulses shall be ignored (that is, not counted) for a period of 100 μs. Each filter is a 2-pole Butterworth low-pass filter with the indicated cut-off (3 dB point) frequency.

Cut-off frequency	Threshold
2 MHz	170 mV
4 MHz	275 mV
10 MHz	560 mV

The impulse noise occurrence rate changes inversely by one decade for each 7 dB change in the threshold voltage. That is, if the noise occurrence rate is 9 counts per 1800 s at a particular threshold voltage, then a rate of 9 counts per 18 000 s will occur at a threshold 7 dB above that voltage. If a count rate of  $N$  counts per

1800 s is measured on a specific cable and filter at the specified voltage threshold, the media noise margin is  $7 \log_{10}(9/N)$  dB.

#### 12.7.4.2 Crosstalk

The level of crosstalk noise on a pair depends on the level of the disturbing signal(s) and the crosstalk attenuation from the pair(s) carrying the signal(s). With the maximum transmit level specified in 12.5.3.1, the sinusoidal crosstalk attenuations specified in 12.7.3.1 and 12.7.3.2, and multiple, synchronized, random Manchester disturbers, the peak self-crosstalk (that is, crosstalk from other 1BASE5 signals) noise levels, as measured through the following specified filters, shall be less than or equal to the levels indicated below. Each filter is a 2-pole Butterworth low-pass filter with the indicated cut-off (3 dB point) frequency.

Cut-off frequency	Level
2 MHz	105 mV
4 MHz	160 mV

### 12.8 Special link specification

#### 12.8.1 Overview

Some 1BASE5 networks may require extension beyond the limits imposed by 12.7 or, due to the installation environment, may require special media such as optical fiber, high-grade cable, or even free-space transmission. The detailed design of special links that replace standard links for use in such circumstances is beyond the scope of this standard, but the end-to-end characteristics are specified. It shall be the responsibility of the supplier to ensure the proper operation of special links with other 1BASE5 equipment.

#### 12.8.2 Transmission characteristics

Special links shall meet the overall attenuation, jitter, and dispersion specifications of 12.7.2.1, 12.7.2.3, and 12.7.2.4, respectively. Total noise introduced due to crosstalk or other sources shall not exceed that allowed for standard media, as specified in 12.7.4. To the extent that it affects operability with 1BASE5 transmitters and receivers, special links shall also meet the impedance and balance requirements of 12.7.2.2 and 12.7.3. The delay and preamble loss allowed for special links is specified in 12.9.4.

#### 12.8.3 Permitted configurations

No more than one special link is permitted in the path between any DTE and the header hub. That is, special links may be installed in parallel but not in series.

NOTE—Special links may be combined with other 1BASE5 components, such as hubs. Such combinations are subject to the performance specifications of this standard only as visible at their external interfaces. For example, explicit MDIs are not required internal to such combinations.

### 12.9 Timing

#### 12.9.1 Overview

The successful interconnection of multivendor system components mandates that delay and bit loss be allocated fairly and realistically among the various system elements. The balance of this subclause defines the upper limits of delay and bit loss allocated to each component. These values allow proper operation with the

worst-case system configuration of five levels of hubs, special links, maximum-length cable segments throughout the network, and colliding DTEs at extremes of the network.

### 12.9.2 DTE timing

DTE Initial Transmit Delay is the time from the first full transition (due to the first OUTPUT\_UNIT of preamble) from the MAC to the first full transition (after startup bit loss, if any) at the MDI. This delay shall not exceed 3 BT. The start bit loss shall not exceed 1 bit.

DTEs shall correctly receive frames that are preceded by 13 or more bits of preamble plus 8 bits of <sfd>.

There is a delay between the reception of signal at the PMA input of a DTE and operation of the deferral process in the MAC. Therefore, there is a window in which a DTE may fail to defer to a transmission even after it has arrived at the input. The DTE Deference Delay is the time from the receipt of the first transition of the preamble at the MDI until the last moment that the DTE might start transmitting at the MDI. This delay includes the following components:

- a) The delay from the first input transition at the MDI to CARRIER\_ON at the PLS-MAC interface
- b) The delay through the MAC processes from CARRIER\_ON to the last moment that a new transmission would miss being deferred
- c) The delay from the first OUTPUT\_UNIT at the MAC-PLS interface to the first output transition at the MDI

The DTE Deference Delay shall be no more than 21 BT.

The DTE Collision Shutdown Delay is the time from the first CVL or CVH arriving at the MDI of a transmitting DTE until that DTE transmits IDL at that interface. This time shall be no more than 26 BT + jamSize=58 BT. This limit shall not start until after the <sfd> has been transmitted.

### 12.9.3 Medium timing

The Medium Transit Delay is the time from when a signal enters the medium until that signal leaves the medium. This delay shall not exceed 4 BT.

### 12.9.4 Special link timing

The Special Link Transit Delay is the time from when a signal enters a special link until that signal leaves the special link. This delay shall not, exceed 15 BT. The preamble leaving a special link shall be no more than 2 bit cells longer than the preamble sent to that special link and no more than 1 bit cell shorter than the preamble sent to that special link. For the purposes of these limits only, the first bit transmitted shall be considered part of the silence of the preceding IDL unless it meets the requirements for the succeeding bits specified in 12.5.3.1.1 and 12.5.3.1.2.

### 12.9.5 Hub timing

Hub Startup Delay is the time from when the first bit cell of the preamble arrives at a hub until the first bit cell (also preamble) leaves that hub. This time shall be no greater than 12 BT. The preamble sent by a hub shall be no more than 1 bit cell longer than the preamble sent to that hub or more than 4 bit cells shorter than the preamble sent to that hub. For the purposes of these limits only, the first bit transmitted shall be considered part of the silence of the preceding IDL unless it meets the requirements for the succeeding bits specified in 12.5.3.1.1 and 12.5.3.1.2.

Hub Idle Collision Startup Delay applies to any case in which CP arrives preceded by fewer (or no) bit times of preamble than the Hub Startup Delay. The time from arrival of the first bit cell (either preamble or CP) until the first bit cell leaves the hub shall be no greater than 12 BT.

Hub Transit Delay is the time from the arrival of any bit cell at a hub to the transmission of the corresponding bit cell from the hub. This delay shall not exceed 9 BT, excluding the cumulative effects of clock tolerance.

The transit (propagation) delay between the upward and downward sides of the Header Hub shall be negligible.

Hub Delay Stretch/Shrink is the increase or decrease in a hub's transit delay due to the effects of differing clock rates. The clock rate tolerance of 0.01% specified in 12.3.2.4.1 and the maximum frame size of 1518 octets specified in 4.4.2 yield a maximum stretch or shrink of  $(56 + 8 + 1518 \cdot 8) \cdot 0.01\% \cdot 2 < 3$  BT, both at any given hub and through an entire network.

Hub Collision Detect Delay is the time required for a hub to detect multiple incoming signals and initiate transmission of CP. The time until transmission of the first CVH or CVL shall be no greater than 21 BT.

Hub Active Collision Startup Delay is the time from the arrival of the first CVH or CVL of a CP pattern at a hub that is repeating bit cells until transmission of the first CVH or CVL from the hub. This delay shall be no greater than 12 BT in either the upward or downward direction.

Hub Collision Shutdown Delay is the time from IDL arriving at a hub that is passing on or generating CP until that hub starts transmitting IDL. This delay shall be limited to 9 BT. The limit is relaxed to 25 BT, however, for the upward side of a hub that is generating CP. This extra allowance is made to avoid requiring implementation of a separate <etd> detection mechanism in each port of the hub.

## 12.10 Safety

Implementors are urged to consult the relevant local, national, and international safety regulations to ensure compliance with the appropriate standards. EIA CB8-1981 (see [B27]) provides additional guidance concerning many relevant regulatory requirements.

Sound installation practice, as defined by applicable codes and regulations, shall be followed. ECMA-97 (see [B26]) describes safety requirements for local area networks.

### 12.10.1 Isolation

Each PMA/MDI interface lead shall be isolated from frame ground. This electrical separation shall withstand at least one of the following electrical strength tests:

- a) 1500 V (rms) at 50 to 60 Hz for 60 s, applied as specified in Section 5.3.2 of IEC 60950: 1991.
- b) 2250 V (dc) for 60 s, applied as specified in Section 5.3.2 of IEC 60950: 1991.
- c) A sequence of ten 2400 V impulses of alternating polarity, applied at intervals of not less than 1 s. The shape of the impulses shall be 1.2/50  $\mu$ s (1.2  $\mu$ s virtual front time, 50  $\mu$ s virtual time of half value), as defined in IEC 60060.

There shall be no insulation breakdown, as defined in Section 5.3.2 of IEC 60950: 1991, during the test. The resistance after the test shall be at least 2 M $\Omega$ , measured at 500 Vdc.

### 12.10.2 Telephony voltages

The use of building wiring brings with it the possibility of wiring errors that may connect telephony voltages to 1BASE5 equipment. Other than voice signals (which are very low voltage), the primary voltages that may be encountered are the “battery” and ringing voltages. Although there is no universal standard that constrains them, the following maximums generally apply:

- a) Battery voltage to an on-hook telephone line is about  $-56$  Vdc applied to the line through a balanced  $400\ \Omega$  source impedance. This voltage is used to power the telephone instrument and detect the off-hook condition. Source inductance can cause large spikes on disconnect.
- b) Battery voltage to an off-hook telephone line is also about  $-56$  Vdc applied to the line through a balanced  $400\ \Omega$  source impedance, but most of the voltage appears across the source impedance because the telephone instrument’s impedance is relatively much lower.
- c) Ringing voltage is a composite signal. The first portion can be up to  $175$  V peak at  $20$  to  $66$  Hz, limited by a  $100\ \Omega$  source resistance or a  $400$  to  $600\ \Omega$  source inductive impedance. The second portion is  $-56$  Vdc limited by a  $300$  to  $600\ \Omega$  source impedance. Large spikes can occur at the start and end of each ring.

Although 1BASE5 equipment is not required to survive such wiring hazards without damage, application of any of the above voltages shall not result in any safety hazard.

NOTE—Wiring errors may impose telephony voltages differentially across the 1BASE5 transmitters or receivers. Because the termination resistance likely to be present across a receiver’s input is of substantially lower impedance than an off-hook telephone instrument, however, receivers will generally appear to the telephone system as off-hook telephones. Full ring voltages, therefore, will be applied for only short periods of time. Transmitters that are coupled using transformers will similarly appear like off-hook telephones (though perhaps a bit more slowly) due to low resistance of the transformer coil.

## 13. System considerations for multisegment 10 Mb/s baseband networks

### 13.1 Overview

This clause provides information on building 10 Mb/s multisegment baseband networks within a single collision domain. The proper operation of a CSMA/CD network requires network size to be limited to control round-trip propagation delay to meet the requirements of 4.2.3.2.3 and 4.4.2, and the number of repeaters between any two DTEs to be limited in order to limit the shrinkage of the interpacket gap as it travels through the network.

This clause provides two network models. Transmission System Model 1 is a set of configurations that have been validated under conservative rules and have been qualified as meeting the two requirements set forth above. Transmission System Model 2 is a set of calculation aids that allow a configuration to be qualified against the two requirements. This set of calculation aids allows those configuring a network to test a proposed configuration against a simple set of criteria that allows it to be qualified. The Model 2 Transmission System Model validates an additional broad set of topologies that are fully functional and do not fit within the simpler but more restrictive rules of Model 1. Figure 13–1 illustrates an example of such a topology. The five repeaters are beyond the scope of the Model 1 rules yet this topology is fully functional within the limits of round-trip delay and can be validated as such by Model 2.

The physical size of a CSMA/CD network is limited by the characteristics of individual network components. These characteristics include the following:

- a) Media lengths and their associated propagation time delay
- b) Delay of repeater units (start-up and steady-state)
- c) Delay of MAUs (start-up and steady-state)
- d) Interpacket gap shrinkage due to repeater units
- e) Delays within the DTE associated with the CSMA/CD access method
- f) Collision detect and deassertion times associated with MAUs

Table 13–1 summarizes the delays for the various network media segments. In addition, Clause 14 summarizes the delays for the 10BASE-T MAU (Table 14–2); Clause 8, the delays for the 10BASE5 MAU; Clause 10, the delays for the 10BASE2 MAU; Clause 9, the delays of the Fiber Optic Inter Repeater Link (FOIRL) and the repeater (Tables 9–1, 9–2, and 9–3); Clause 16, the delays for the 10BASE-FP MAU (Table 16–1, also see 15.1); Clause 17, the delays for the 10BASE-FB MAU (Table 17–1, also see 15.1), and Clause 18, the delays for the 10BASE-FL MAU (Table 18–1, also see 15.1).

**Table 13–1—Delays for network media segments**

Media type	Maximum number of MAUs per segment	Maximum segment length (m)	Maximum medium delay per segment (ns)
Mixing segment			
10BASE5	100	500	2165
10BASE2	30	185	950
10BASE-FP	33 <sup>a</sup>	1000 <sup>b</sup>	5000
Link segment			
FOIRL	2	1000	5000
10BASE-T	2	100 <sup>c</sup>	1000
10BASE-FB	2	2000	10 000
10BASE-FL	2	2000	10 000
AUI <sup>d</sup> 1 DTE/1 MAU		50	257

<sup>a</sup>Actual number depends on the passive-star characteristics; see 16.5.2.1.

<sup>b</sup>In addition, a MAU to passive-star link will not exceed 500 m.

<sup>c</sup>Actual maximum segment length depends on cable characteristics; see 14.1.1.3.

<sup>d</sup>AUI is not a segment.

For a more detailed description of the calculation methods used to arrive at Transmission System Model 2, see B.1.5.

### 13.1.1 Repeater usage

Repeaters are the means used to connect segments of network medium together, thus allowing larger topologies and a larger MAU base than are allowed by the rules governing individual segments. Different media/segment types can only be connected to each other using repeaters.

## 13.2 Definitions

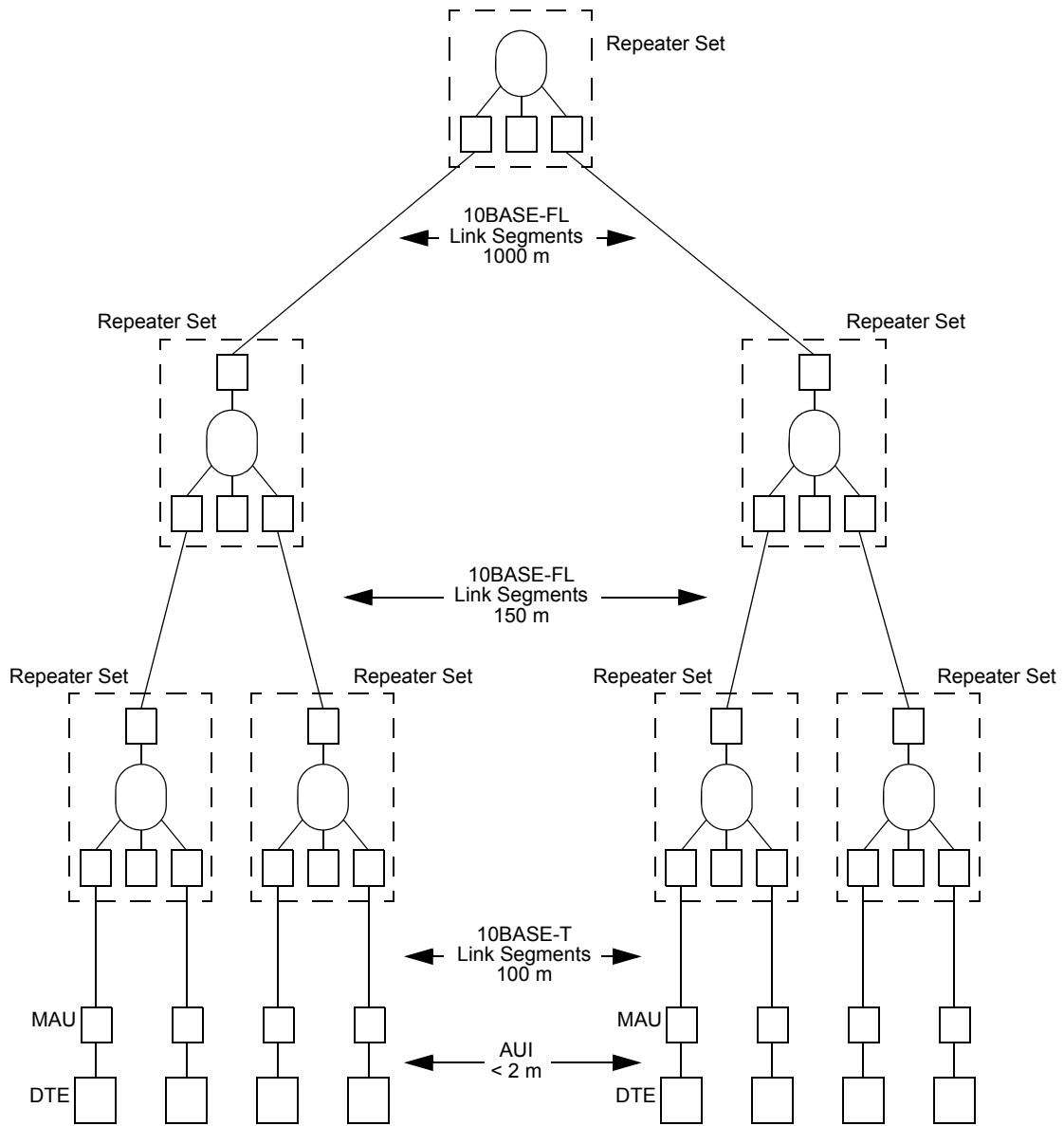
See 1.4.

## 13.3 Transmission System Model 1

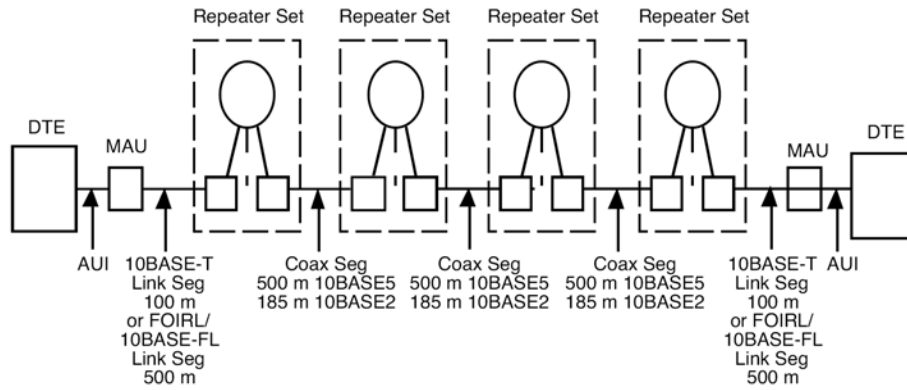
The following network topology constraints apply to networks using Transmission System Model 1. If no segment length constraints are given for a segment type, the maximum segment length, as defined in the relevant MAU clause, applies.

- a) Repeater sets are required for all segment interconnection.
- b) MAUs that are part of repeater sets count toward the maximum number of MAUs on a segment.
- c) The transmission path permitted between any two DTEs may consist of up to five segments, four repeater sets (including optional AUIs), two MAUs, and two AUIs.
- d) AUI cables for 10BASE-FP and 10BASE-FL shall not exceed 25 m. (Since two MAUs per segment are required, 25 m per MAU results in a total AUI cable length of 50 m per segment.)
- e) When a transmission path consists of four repeater sets and five segments, up to three of the segments may be mixing and the remainder must be link segments (Figure 13–2, Figure 13–3, and Figure 13–6). When five segments are present, each fiber optic link segment (FOIRL, 10BASE-FB, or 10BASE-FL) shall not exceed 500 m, and each 10BASE-FP segment shall not exceed 300 m.
- f) When a transmission path consists of three repeater sets and four segments (Figure 13–4 and Figure 13–5), the following restrictions apply:
  - 1) The maximum allowable length of any inter-repeater fiber segment shall not exceed 1000 m for FOIRL, 10BASE-FB, and 10BASE-FL segments and shall not exceed 700 m for 10BASE-FP segments.
  - 2) The maximum allowable length of any repeater to DTE fiber segment shall not exceed 400 m for 10BASE-FL segments and shall not exceed 300 m for 10BASE-FP segments and 400 m for segments terminated in a 10BASE-FL MAU.
  - 3) There is no restriction on the number of mixing segments in this case.

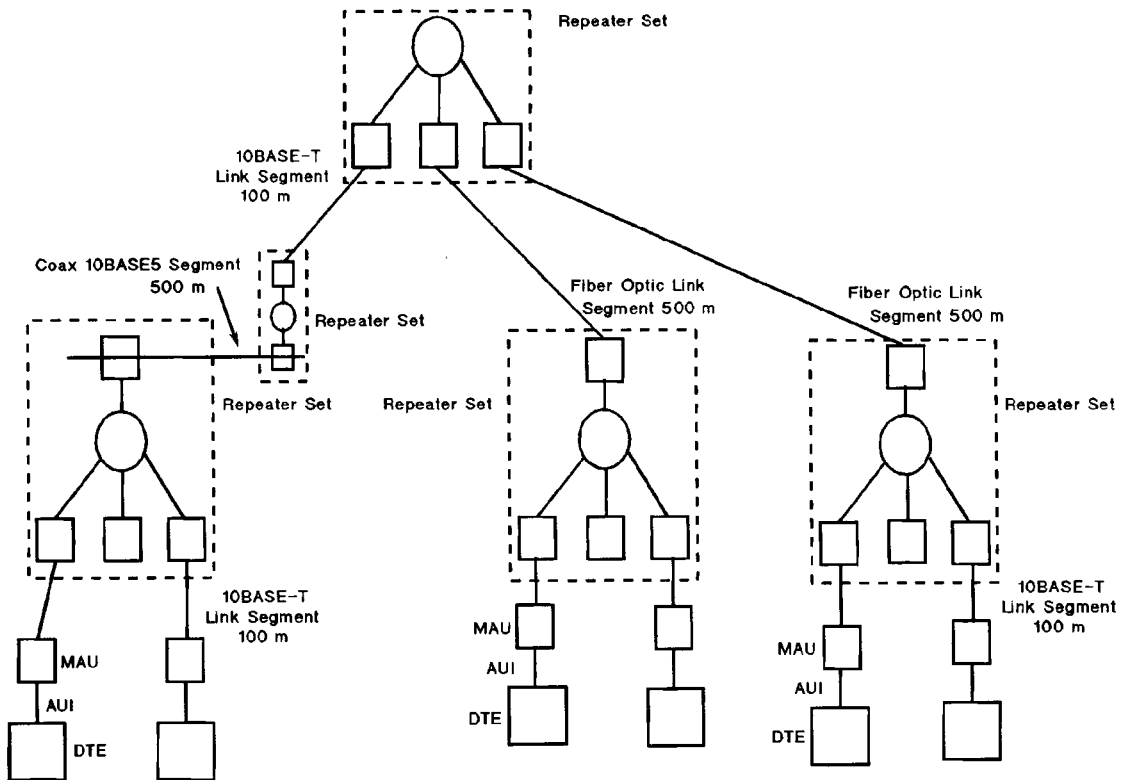




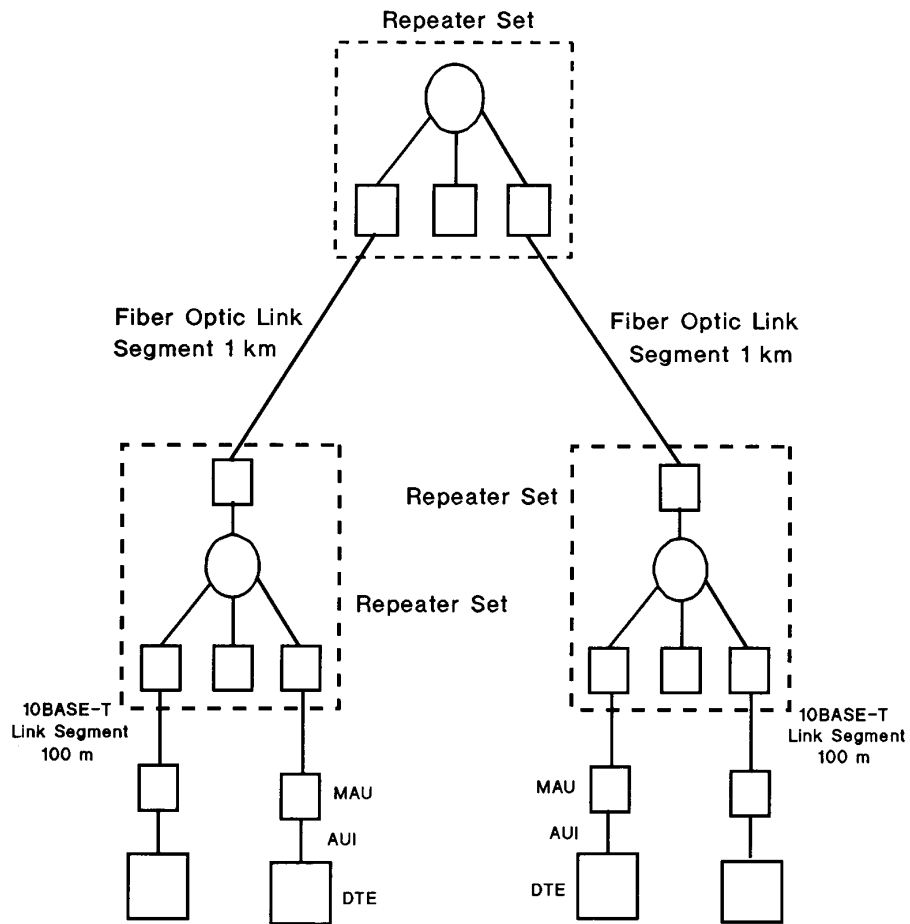
**Figure 13-1—Example of maximum transmission path with five repeater sets enabled by Model 2 Transmission System validation**



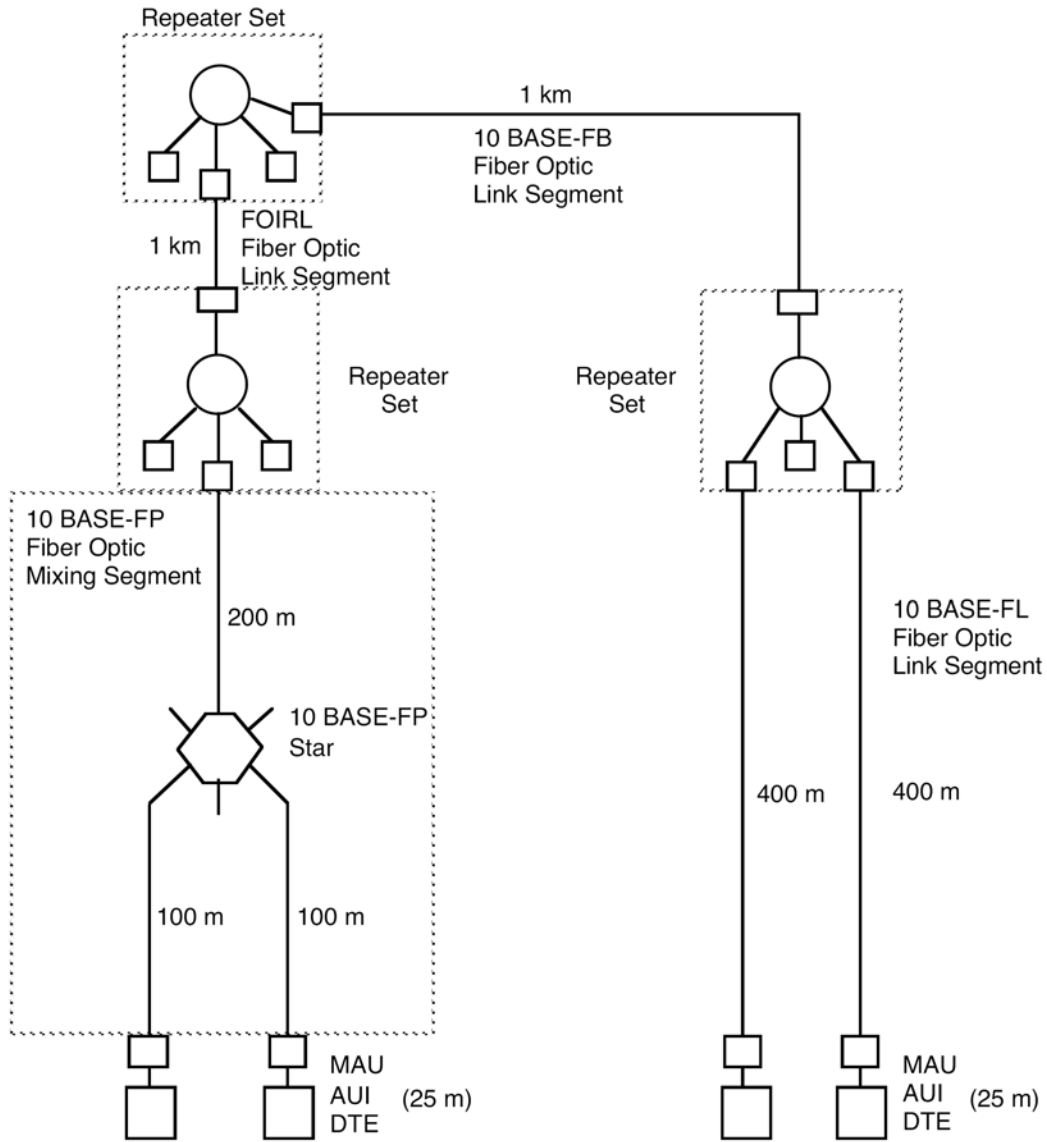
**Figure 13-2—Maximum transmission path with three coaxial cable segments and two link segments**



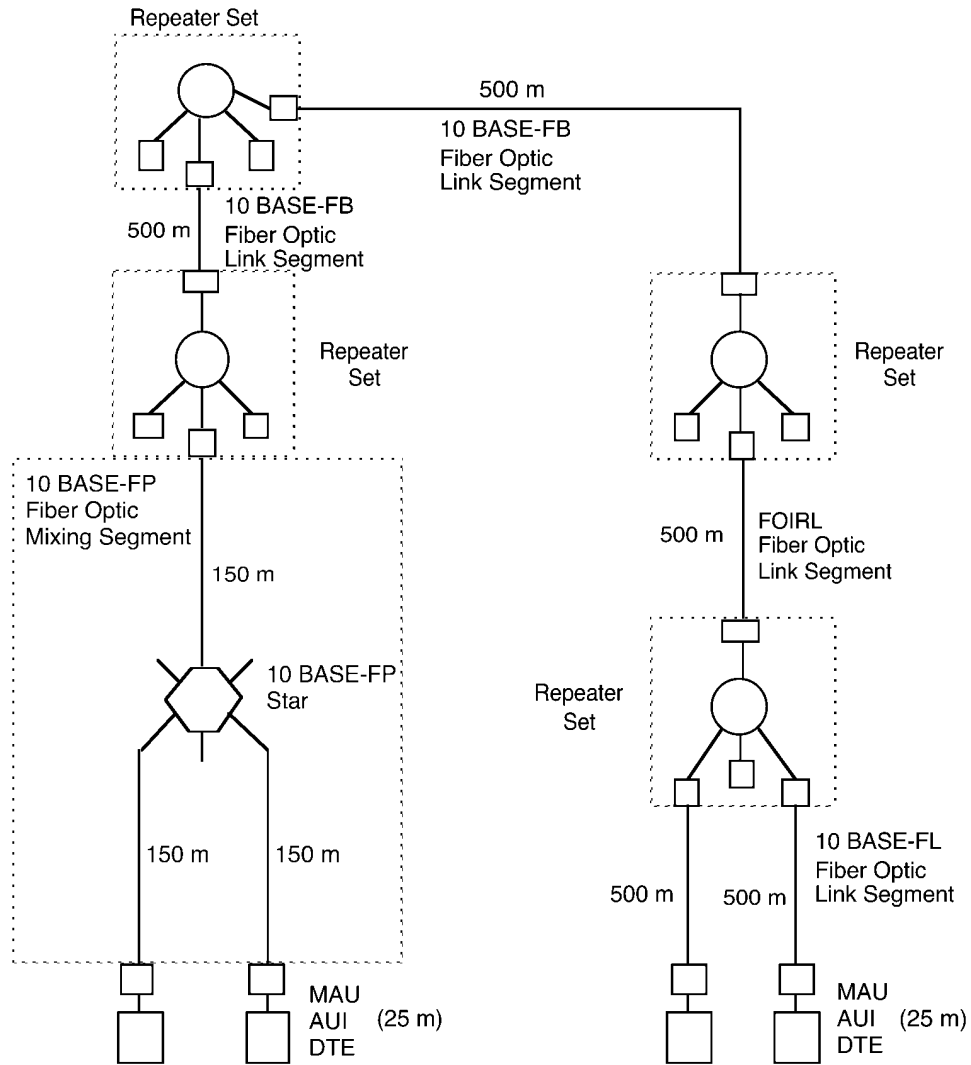
**Figure 13-3—Example of maximum transmission path using coaxial cable segments, 10BASE-T link segments, and fiber optic link segments**



**Figure 13-4—Example of maximum transmission path with three repeater sets, four link segments (two are 100 m 10BASE-T and two are 1 km fiber)**



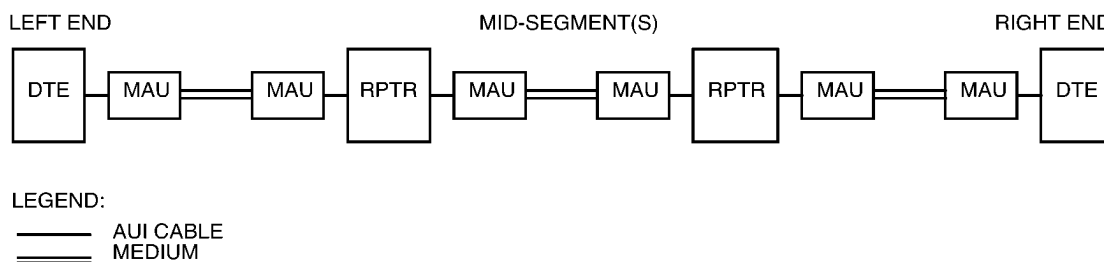
**Figure 13-5—Example of maximum transmission path with three repeater sets, four segments (one 1 km 10BASE-FB, one 1 km FOIRL, one 400 m 10BASE-FL, and one 300 m 10BASE-FP)**



**Figure 13-6—Example of maximum transmission path with four repeater sets, five segments (two 500 m 10BASE-FB, one 500 m FOIRL, one 500 m 10BASE-FL, and one 300 m 10BASE-FP)**

## 13.4 Transmission System Model 2

The physical size and number of topological elements in a 10 Mb/s baseband network is limited by two factors, round-trip collision delay and interpacket gap shrinkage. A network configuration must be validated against each of these separately. A model of the network is required for each of the calculations. The model consists of a series of segments consisting of a left-end segment, mid-segments, and a right-end segment. The model of the network used in the calculations consists of the worst-case path through the network for that particular calculation. The calculations are sufficiently straightforward that they can be done manually. They are also easy to implement in a spreadsheet. In general, the worst-case path for the two calculations is not the same for any single network. The requirements for each calculation and its respective model are detailed in the following subclauses and in Figure 13–7.



**Figure 13–7—Generalized transmission path model**

### 13.4.1 Round-trip collision delay

For a network to be valid, it must be possible for any two DTEs on that network to contend for the network at the same time. Each station attempting to transmit must be notified of the contention by the returned “collision” signal within the “collision window” (see 4.1.2.2 and 5.2.2.1.10). Additionally, the maximum length fragment created must contain less than 511 bits after the Start Frame Delimiter (SFD). This requirement limits the physical diameter (maximum distance between DTEs) of a network. The maximum round-trip delay must be qualified between all pairs of DTEs in the network. In practice this means that the qualification must be done between those that, by inspection of the topology, are candidates for the longest delay.

The following network modeling methodology is provided to assist that calculation.

#### 13.4.1.1 Worst-case path delay value (PDV) selection

The worst-case path through a network to be validated shall be identified. The worst case consists of the path between the two DTEs at opposite ends of the network that have the longest round-trip time (see Figure 13–7).

#### 13.4.1.2 Worst-case PDV calculation

Once a set of paths is chosen for calculation, each shall be checked for validity against the following formulas. (If a candidate for worst-case path has end segments of different types, calculations for the path must be performed twice, considering first one end segment as the left end, and then the other, and the maximum value obtained used as the PDV.)

- a) Determine the Segment Delay Value (SDV) from Table 13–2 for each of the segments in the path.

$$SDV = \text{Base} + [\text{Length} \times (\text{Round-Trip Delay}/\text{meter})]$$

(For mixing segments, length is the length between the repeater and the farthest end of the segment for end segments, or the length between two repeaters for mid-segments.)

or

$$SDV = \text{Max}$$

(Max is equal to the value above for the maximum media segment length. It is provided for ease of calculation with segments that are at their maximum length or as a default value when the length is not known).

NOTE—The SDV figure in the table includes allowance for an AUI at each end of the segment (except for 10BASE-FB) and up to 2 m of AUI cable. In 10BASE5 segments, AUI cables are normally longer than 2 m. Care should be exercised to assure that provision is made for the delay associated with their actual length.

- b) From Table 13–2, determine the SDV for the sum of all AUI cables in excess of 2 m (except the AUI associated with the left end DTE, which does not contribute to the PDV).
- c) Sum all SDVs from item a) and item b) plus a margin of up to 5 bits to form the PDV. The margin may be from 0 to 5 bits; 5 bits is recommended. If the PDV is less than or equal to 575, the path is qualified in terms of worst-case delay.

**Table 13–2—Segment round-trip delay values in bit times  
(PDV not to exceed 572)**

Segment type	Max length	Left end		Mid-segment		Right end		RT delay/ meter
		Base	Max	Base	Max	Base	Max	
10BASE5 Coax	500	11.75	55.05	46.5	89.8	169.5	212.8	0.0866
10BASE2 Coax	185	11.75	30.731	46.5	65.48	169.5	188.48	0.1026
FOIRL	1000	7.75	107.75	29	129	152	252	0.1
10BASE-T	100 <sup>a</sup>	15.25	26.55	42	53.3	165	176.3	0.113
10BASE-FP	1000	11.25	111.25	61	161	183.5	284	0.1
10BASE-FB	2000	N/A <sup>b</sup>	N/A <sup>b</sup>	24	224	N/A <sup>b</sup>	N/A <sup>b</sup>	0.1
10BASE-FL	2000	12.25	212.25	33.5	233.5	156.5	356.5	0.1
Excess length AUI	48	0	4.88	0	4.88	0	4.88	0.1026

<sup>a</sup>Actual maximum segment length depends on cable characteristics; see 14.1.1.3.

<sup>b</sup>Not Applicable, 10BASE-FB does not support end connections.

### 13.4.2 Interpacket gap (IPG) shrinkage

The worst-case variabilities of transmission elements in the network plus some of the signal reconstruction facilities required in the 10 Mb/s baseband repeater specification combine in such a way that the gap between two packets travelling across the network may be reduced below the interFrameGap specified in 4.4.2. This parameter limits the equipment (i.e., number of repeaters) between any two DTEs. Again this limit applies to all combinations of DTEs on any network but the worst case is apparent from an inspection of a map or schematic representation of the topology in question.

### 13.4.2.1 Worst-case path variability value (PVV) selection

A worst-case path through a network to be validated shall be identified.

It should be noted that the receive end segment is not counted in this scenario. This means that in an asymmetrical network where the end segments are of different types, the end segment with the worst variability shall be designated as the “Transmitting End” for this evaluation.

### 13.4.2.2 Worst-case path variability value (PVV) calculation

Once a set of paths is chosen for calculation each shall be checked for qualification by the following method:

- a) Determine the Segment Variability Value (SVV) from Table 13–3 for each of the segments in the Path, excluding the end segment with the lower SVV.
- b) Sum all of the SVVs from item 1 to form the PVV. If the PVV is less than or equal to 49, the path is qualified in terms of worst-case variability.

**Table 13–3—Segment variability values in bit times  
(PVV not to exceed 49)**

Segment type	Transmitting end	Mid-segment
Coax	16	11
Link except 10BASE-FB	10.5	8
10BASE-FB	N/A <sup>a</sup>	2
10BASE-FP	11	8

<sup>a</sup>Not Applicable, 10BASE-FB does not support end connections.

## 13.5 Full duplex topology limitations

Unlike half duplex CSMA/CD networks, the physical size of full duplex 10 Mb/s networks is not limited by the round-trip collision propagation delay. Instead, the maximum link length between DTEs is limited only by the signal transmission characteristics of the specific cable.



## 14. Twisted-pair medium attachment unit (MAU) and baseband medium, type 10BASE-T

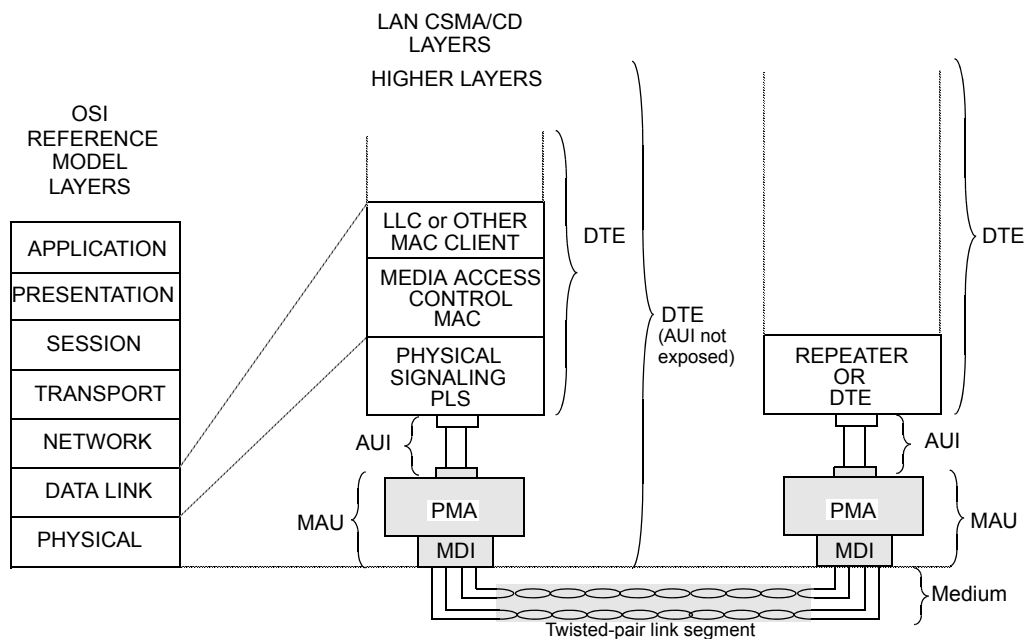
### 14.1 Scope

#### 14.1.1 Overview

Clause 14 defines the functional, electrical, and mechanical characteristics of the type 10BASE-T MAU and one specific medium for use with that MAU. The relationship of this clause to the entire ISO/IEC 8802-3 LAN International Standard is shown in Figure 14-1. The purpose of the MAU is to provide a simple, inexpensive, and flexible means of attaching devices to the medium.

This MAU and medium specification is aimed primarily at office applications where twisted-pair cable is often installed. Installation and reconfiguration simplicity is allowed by the type of cable and connectors used.

The 10BASE-T specification builds upon Clause 1 through Clause 7 and Clause 9 of this standard.



**Figure 14-1—10BASE-T relationship to the ISO/IEC Open Systems Interconnection (OSI) reference model and the IEEE 802.3 CSMA/CD LAN model**

#### 14.1.1.1 Medium Attachment Unit (MAU)

The MAU has the following general characteristics:

- Enables coupling the Physical Signaling (PLS) sublayer by way of the Attachment Unit Interface (AUI) to the baseband twisted-pair link defined in Clause 14.
- Supports message traffic at a data rate of 10 Mb/s.
- Provides for operating over 0 m to at least 100 m of twisted pair without the use of a repeater.
- Permits the Data Terminal Equipment (DTE) or repeater to confirm operation of the MAU and availability of the medium.

- e) Supports network configurations using the CSMA/CD access method defined in this standard with baseband signaling.
- f) Supports a point-to-point interconnection between MAUs and, when used with repeaters having multiple ports, supports a star wiring topology.
- g) Allows incorporation of the MAU within the physical bounds of a DTE or repeater.
- h) Allows for either half duplex operation, full duplex operation, or both.

#### **14.1.1.2 Repeater unit**

The repeater unit is used to extend the physical system topology and provides for coupling two or more segments. Repeaters are an integral part of all 10BASE-T networks with more than two DTEs (see Figure 13–1 and Figure 13–2). The repeater unit is defined in Clause 9. Multiple repeater units are permitted within a single collision domain to provide the maximum connection path length specified in Clause 13. The repeater unit is not a DTE and therefore has slightly different requirements for its attached MAUs, as defined in 9.4.1. Repeater sets with 10BASE-T MAUs are required to provide the auto-partition/reconnection algorithm on those ports, as specified in 9.6.6.2.

#### **14.1.1.3 Twisted-pair media**

The medium for 10BASE-T is twisted-pair wire. The performance specifications of the simplex link segment are contained in 14.4. This wiring normally consists of 0.4 mm to 0.6 mm diameter [26 AWG to 22 AWG] unshielded wire in a multipair cable. The performance specifications are generally met by 100 m of 0.5 mm telephone twisted pair. Longer lengths are permitted providing the simplex link segment meets the requirements of 14.4. A length of 100 m, the design objective, will be used when referring to the length of a twisted-pair link segment.

#### **14.1.2 Definitions**

See 1.4 for additional definitions.

**14.1.2.1 twisted-pair link:** A twisted-pair link segment and its two attached MAUs (see Figure 14–1).

**14.1.2.2 twisted-pair link segment (duplex link segment):** Two simplex link segments for connecting two MAUs (see Figure 14–2).

#### **14.1.3 Application perspective**

This clause states the broad objectives and assumptions underlying the specifications defined throughout Clause 14.

##### **14.1.3.1 Objectives**

- a) Provide the physical means for communication between LAN Data Link Layer entities.
- b) Ensure compatibility of independently developed physical and electrical interfaces.
- c) Provide a communication channel with a mean bit error ratio, at the Physical Layer service interface of less than one part in  $10^8$ .
- d) Provide for ease of installation and service.
- e) Ensure that fairness of DTE access is not compromised.
- f) Provide for low-cost networks, as related to both equipment and cabling.
- g) Make use of telephone twisted-pair building wiring and telephony wiring practices.

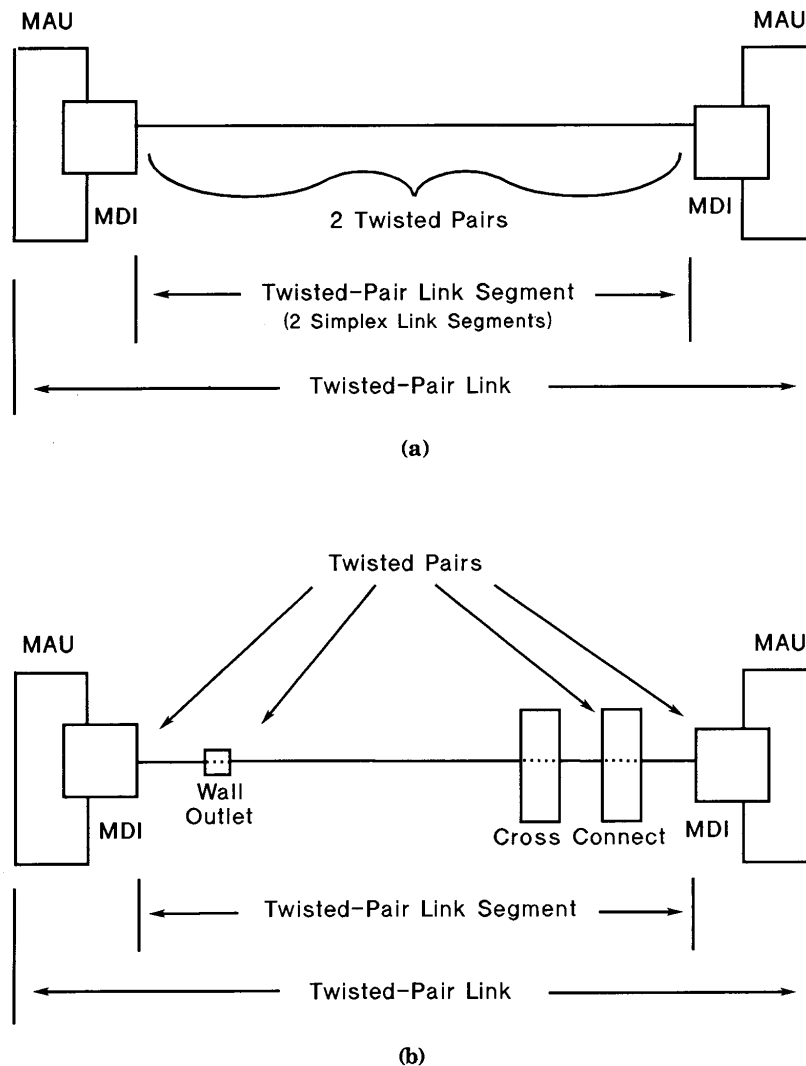


Figure 14-2—Twisted-pair link

### 14.1.3.2 Compatibility considerations

All implementations of the twisted-pair link shall be compatible at the MDI. The MAU and the medium are defined to provide compatibility among devices designed by different manufacturers. Designers are free to implement circuitry within the MAU in an application-dependent manner provided the MDI and AUI (when implemented) specifications are met.

### 14.1.3.3 Modes of operation

The 10BASE-T MAU is capable of operating in *normal* mode only (see 7.1.4). The MAU shall not operate in *monitor* mode.

When normal mode is in operation, the MAU functions as a direct connection between the medium and the DTE or repeater. Data from the DTE or repeater is output to one of the simplex link segments of the link segment, and data received on the other simplex link segment is input to the DTE or repeater.

The operation of a 10BASE-T MAU differs depending on whether the attached DTE is operating in the half duplex or full duplex mode (see 1.1.2). In the full duplex mode, functions relating to the loopback of transmitted data (DO) onto the receive path (DI) are disabled (see 14.2.1.3 and 14.2.1.6). The requirements specified in subclauses of this standard labeled “half duplex mode only” do not apply to a MAU used with a DTE configured for full duplex operation.

#### 14.1.4 Relationship to PLS and AUI

A close relationship exists between Clause 14 and Clause 7. Clause 14 specifies the physical medium parameters and the PMA logical functions residing in the physical MAU. The MAU provides services to the PLS defined in Clause 7 by means of the AUI. 10BASE-T MAUs support a subset of the AUI services specified in Clause 7. 10BASE-T MAUs do not support the optional isolate function, the optional CO circuit, or the optional CS1 signal on the CI circuit.

The design of an external MAU component requires the use of both Clause 14 and Clause 7 for the PLS and AUI specifications.

The figures and numerous textual references throughout Clause 14 refer to terminology associated with the AUI (that is, DO, DI, and CI). Since an embodiment of the 10BASE-T MAU does not require the implementation of an AUI, the DO, DI, and CI circuits may not physically exist. However, they are logically present and MAU operation is defined in terms of them.

### 14.2 MAU functional specifications

The MAU provides the means by which signals on the three AUI signal circuits to and from the DTE or repeater and their associated interlayer messages are coupled to the twisted-pair link segment. The MAU provides the following functional capabilities to handle message flow between the DTE or repeater and the twisted-pair link segment:

- a) Transmit function. Provides the ability to transfer Manchester-encoded data from the DO circuit to the TD circuit. While not sending Manchester-encoded data on the TD circuit, the MAU sends an idle signal, TP\_IDL, on the TD circuit.
- b) Receive function. Provides the ability to transfer Manchester-encoded data from the RD circuit to the DI circuit. While not sending Manchester-encoded data on the DI circuit, the MAU sends an idle signal, IDL, on the DI circuit.
- c) Loopback function (half duplex mode only). Provides the ability to transfer Manchester-encoded data from the DO to the DI circuit when the MAU is sending Manchester-encoded data to the TD circuit.
- d) Collision Presence function. Provides the ability to detect simultaneous occurrence of Manchester-encoded data on the RD and DO circuits and to report such an occurrence as a collision. MAUs connected to full duplex mode DTEs are permitted, but not required, to implement the Collision Presence function.
- e) *signal\_quality\_error* Message (SQE) Test function. Provides the ability to indicate to the DTE that the Collision Presence function is operational and that the *signal\_quality\_error* message can be sent by the MAU.
- f) Jabber function. Provides the ability to prevent abnormally long reception of Manchester-encoded data on the DO circuit from indefinitely disrupting transmission on the network. While such a condition is present, transfer of Manchester-encoded data by the Transmit and Loopback functions is disabled.
- g) Link Integrity Test function. Provides the ability to protect the network from the consequences of failure of the simplex link attached to the RD circuit. While such a failure is present, transfer of Manchester-encoded data by the Transmit, Receive, and Loopback functions is disabled.

- h) Auto-Negotiation. Optionally provides the capability for a device at one end of a link segment to advertise its abilities to the device at the other end (its link partner), to detect information defining the abilities of the link partner, and to determine if the two devices are compatible.

### 14.2.1 MAU functions

The MAU shall provide the Transmit, Receive, Loopback, Collision Presence, Jabber, and Link Integrity Test functions for half duplex mode DTEs and repeater units. The MAU shall provide the Transmit, Receive, Jabber, and Link Integrity Test functions, and shall not provide the Loopback function for full duplex mode DTEs. The SQE Test function shall be performed by MAUs that are connected to half duplex DTEs and shall not be performed by MAUs that are connected to repeaters.

MAUs connected to full duplex mode DTEs are permitted, but not required, to implement the Collision Presence function, the SQE Test function, and the generation of the CS0 signal on the CI circuit by the Jabber function. If these optional capabilities are implemented in a MAU connected to a full duplex mode DTE, either all of the optional functions shall be implemented, or none of them shall be.

The MAU function requirements are summarized in the table below:

MAU connected to:			
Functions	Repeater	Half duplex DTE	Full duplex DTE
Transmit	Required	Required	Required
Receive	Required	Required	Required
Loopback	Required	Required	Required
Jabber	Required	Required	Required
Link Integrity Test	Required	Required	Required
Collision Presence	Required	Required	Optional (Note 2)
SQE Test	Required	Required	Optional (Note 2)
Generation of CS0 signal on the CI circuit by jabber	Required	Required	Optional (Note 2)

NOTE 1—The functional requirements of a MAU connected to a full duplex DTE are a proper subset of the requirements for half duplex operation.

NOTE 2—Optional capabilities, if implemented, must be implemented as a group (i.e., all or none).

A capability may be provided in the MAU to activate or inhibit the SQE Test function, or to configure the MAU for full or half duplex operation. It is not required that a MAU determine that it is connected to either a DTE or a repeater and automatically activate or inhibit the SQE Test function. It is also not required that a MAU determine that it is connected to either a half duplex or full duplex DTE and automatically activate or inhibit the appropriate functions for those modes. The use of the Auto-Negotiation algorithm of Clause 28 in 10BASE-T MAUs is discussed in 14.2.1.8. The MAU may optionally provide the Auto-Negotiation algorithm. When provided, the Auto-Negotiation algorithm shall be implemented in accordance with Clause 28.

#### 14.2.1.1 Transmit function requirements

The MAU shall receive the signals on the DO circuit and send them to the TD circuit of the MDI. A positive signal on the A lead relative to the B lead of the DO circuit shall result in a positive signal on the TD+ (Transmit Data +) lead of the MDI with respect to the TD– lead.

At the start of a packet transmission, no more than 2 bits may be received from the DO circuit and not transmitted on the TD circuit. In addition, it is permissible for the first bit sent to contain phase violations or invalid amplitude. All subsequent bits of the packet shall be reproduced with the differential voltage specified in 14.3.1.2.1 and with no more jitter than is specified in 14.3.1.2.3. The second bit transmitted on the

TD circuit shall be transmitted with the correct timing and signal levels. The steady-state propagation delay between the DO circuit input and the TD circuit shall not exceed 2 BT.

For any two packets that are separated by 9.6  $\mu$ s or less, the start-up delay (bit loss plus steady-state propagation delay) of the first packet shall not exceed that of the second packet by more than 2 BT.

Whenever data is not being transmitted on the TD circuit, an idle signal, TP\_IDL, shall be transmitted on the TD circuit. TP\_IDL is a start of idle, as defined in 14.3.1.2.1, followed by a repeating sequence of a 16 ms  $\pm$  8 ms period of silence (the time where the differential voltage remains at 0 mV  $\pm$  50 mV) and a link test pulse (see 14.3.1.2.1). Following a packet and start of idle, the repeating sequence shall start with a period of silence.

Transmission of TP\_IDL may be terminated at any time with respect to the link test pulse. It shall be terminated such that no more than the first transmitted bit of a packet is corrupted, and with no more delay than is specified for bit loss and steady-state propagation.

For a MAU that implements the Auto-Negotiation algorithm defined in Clause 28, Clause 28 shall define the allowable transmitted link pulse sequence.

#### **14.2.1.2 Receive function requirements**

The MAU shall receive the signals on the RD circuit of the MDI and send them to the DI circuit. A positive signal on the RD+ (Receive Data +) lead relative to the RD– lead of the MDI shall result in a positive signal on the A lead with respect to the B lead of the DI circuit.

At the start of a packet reception from the RD circuit, no more than 5 bits may be received on the RD circuit and not transmitted onto the DI circuit. In addition, it is permissible for the first bit sent on the DI circuit to contain phase violations or invalid data; however, all successive bits of the packet shall be sent with no more than the amount of jitter specified in 14.3.1.3.1. The steady-state propagation delay between the RD circuit and the DI circuit shall not exceed 2 BT.

For any two packets that are separated by 9.6  $\mu$ s or less, the start-up delay of the first packet shall not exceed that of the second packet by more than 2 BT.

#### **14.2.1.3 Loopback function requirements (half duplex mode only)**

When the MAU is transmitting on the TD circuit and is not receiving *RD\_input* messages (14.2.2.4) on the RD circuit, the MAU shall transmit on the DI circuit the signals received on the DO circuit in order to provide loopback of the transmitted signal. At the start of packet transmission on the TD circuit, no more than 5 bits of information may be received from the DO circuit and not transmitted to the DI circuit. In addition, it is permissible for the first bit sent on the DI circuit to contain phase violations or invalid data; however, all successive bits of the packet shall meet the jitter specified in 14.3.1.3.1 (that is, 13.5 ns plus 1.5 ns). The steady-state propagation delay between the DO circuit and the DI circuit shall not exceed 1 BT.

#### **14.2.1.4 Collision Presence function requirements (half duplex mode only)**

The MAU shall detect as a collision the simultaneous occurrence of activity on the DO circuit and the RD circuit while in the Link Test Pass state. While a collision is detected, a CS0 signal (see 7.3.1.2) shall be sent on the CI circuit. The signal shall be presented to the CI circuit no more than 9 BT after the occurrence of a collision. The signal shall be deasserted within 9 BT after the DO circuit or the RD circuit changes from active to idle.

When CS0 is asserted on the CI circuit due to a collision, the data on the RD circuit shall be sent to the DI circuit within 9 BT.

When the RD circuit changes from active to idle and data is present on the DO circuit, the data on the DO circuit shall be sent to the DI circuit within 9 BT.

The signal presented on the CI circuit in the absence of collision, SQE test, or Jabber shall be the IDL signal.

MAUs connected to full duplex mode DTEs are permitted, but not required, to implement the Collision Presence function (see 14.2.1).

#### 14.2.1.5 *signal\_quality\_error* Message (SQE) Test function requirements

The SQE Test function shall be performed by MAUs that are connected to DTEs in half duplex mode, and shall not be performed by MAUs that are connected to repeaters. When the SQE test is performed, the MAU shall send CS0 on the CI circuit for a time “SQE\_test” beginning a time “SQE\_test\_wait” after the last positive transition of a packet on the DO circuit. The value of “SQE\_test” shall be  $10 \text{ BT} \pm 5 \text{ BT}$  and the value of “SQE\_test\_wait” shall be between  $0.6 \mu\text{s}$  and  $1.6 \mu\text{s}$ . This function should use as much of the normal collision detection and signaling circuitry as possible without introducing extraneous signals on the TD circuit or the DI circuit.

The CS0 signal shall not be sent by the SQE Test function while in any of the Link Test Fail states.

MAUs connected to full duplex mode DTEs are permitted, but not required, to implement the SQE Test function (see 14.2.1).

#### 14.2.1.6 Jabber function requirements

The MAU shall contain a self-interrupt capability to prevent an illegally long transmission by a DTE from permanently disrupting transmission on the network and to disable loopback to the DI circuit (Figure 14–5). The MAU shall provide a window “xmit\_max” during which time the Transmit function may continuously transmit *TD\_output* messages to the TD circuit. The value of “xmit\_max” shall be between 20 and 150 ms. If a transmission exceeds this duration, the Jabber function shall

- a) Inhibit the Loopback function and the transmission of *TD\_output* messages by the Transmit function, and shall
- b) Send the CS0 signal on the CI circuit, when the MAU is connected to a DTE operating in half duplex mode. MAUs connected to DTEs operating in full duplex mode are permitted, but not required, to send the CS0 signal on the CI circuit in this manner (see 14.2.1).

These actions shall continue until *output\_idle* has been continuously present on the DO circuit for a time “unjab.” The value of “unjab” shall be  $0.5 \text{ s} \pm 0.25 \text{ s}$ .

It is permissible to activate the Jabber function when the TD circuit transmitter is sending *TD\_output* messages for longer than “xmit\_max.”

The MAU shall not activate its Jabber function when the repeater’s MAU Jabber Lockup Protection function operates at its longest permitted time as specified in 9.6.5.

#### 14.2.1.7 Link Integrity Test function requirements

In order to protect the network from the consequences of a simplex link segment failure, the MAU shall monitor the RD circuit for *RD\_input* and link test pulse activity. If neither *RD\_input* nor a link test pulse is received for a time “link\_loss,” the MAU shall enter the Link Test Fail state and cause the *input\_idle* message to be sent on the DI circuit and the *TD\_idle* message to be sent on the TD circuit (Figure 14–6). The value of “link\_loss” shall be between 50 ms and 150 ms. When *RD\_input* or a number “lc\_max” of consec-

utive link test pulses is received on the RD circuit, the MAU shall exit the Link Test Fail state. The value of “lc\_max” shall be between 2 and 10 inclusive.

Only link test pulses that occur within time “link\_test\_max” of each other shall be considered consecutive. The value of “link\_test\_max” shall be between 25 ms and 150 ms. In addition, detected pulses that occur within a time “link\_test\_min” of a previous pulse or packet shall be ignored while in the Link Test Pass state. In the Link Test Fail state, such pulses shall reset the counted number of consecutive link test pulses to zero. The value of “link\_test\_min” shall be between 2 ms and 7 ms. Re-enabling shall be deferred until the signals on the RD and DO circuits become idle. The MAU shall not detect a link test pulse as *RD\_input*. Additionally, a MAU may exit the Link Test Fail Extend state and enter the Link Test Pass state when the RD circuit becomes idle and the Jabber function has disabled transmission on the TD circuit.

While the MAU is not in the Link Test Pass state, the Link Integrity Test function shall disable the bit transfer of the Transmit, Receive, and Loopback functions, and the Collision Presence and SQE Test functions.

At PowerOn, in place of entering the Link Test Pass state as shown in Figure 14–6, a MAU may optionally enter the Link Test Fail Reset state.

For a MAU that implements the Auto-Negotiation algorithm defined in Clause 28, the MAU shall enter the LINK TEST FAIL RESET state at power-on as specified in Clause 28. For a MAU that does not implement the Auto-Negotiation algorithm defined in Clause 28, it is highly recommended that it also power-on in the LINK TEST FAIL RESET state, although implementations may power-on in the LINK TEST PASS state. For a MAU that implements the Auto-Negotiation function defined in Clause 28, the Auto-Negotiation Technology Dependent Interface shall be supported. Supporting the Technology Dependent Interface requires that in the Link Integrity Test function state diagram “link\_status=OK” is added to the LINK TEST PASS state and “link\_status=FAIL” is added to the LINK TEST FAIL RESET state. Note these ISO message variables follow the conventions of Clause 21.

If a visible indicator is provided on the MAU to indicate the link status, it is recommended that the color be green and that the indicator be labeled appropriately. It is further recommended that the indicator be on when the MAU is in the Link Test Pass state and off otherwise.

#### 14.2.1.8 Auto-Negotiation

It is strongly recommended that Auto-Negotiation be used for the determination of half or full duplex operation. When Auto-Negotiation is used in an exposed AUI-based MAU implementation, the MAU must be capable of operating in the half duplex mode, and shall not advertise the ability to operate in full duplex mode.

10BASE-T MAUs used in an embedded system (i.e., where the MAU is incorporated within the physical bounds of the DTE), or incorporating a physical implementation of the MII interface of Clause 22 with a DTE operating in full duplex mode, may indicate the capability to operate in full duplex mode using the Auto-Negotiation algorithm in accordance with Clause 28.

NOTE—Since there is no way to communicate the half or full duplex abilities between a DTE or repeater and a MAU separated by an AUI, caution must be used when connecting full duplex capable DTEs or MAUs that are manually configured.

Manual configuration is not recommended. Connecting incompatible DTE/MAU combinations such as a full duplex mode DTE to a half duplex mode MAU, or a full-duplex mode station (DTE and MAU) to a repeater or other half duplex network, can lead to severe network performance degradation, increased collisions, late collisions, CRC errors, and undetected data corruption.



### 14.2.2 PMA interface messages

The messages between the PLS in the DTE and the PMA in the MAU shall comply with the PMA interface messages described in 7.2.1. These messages also are used in repeater unit to PMA communication. These and the messages between the PMAs over the MDI are summarized below.

#### 14.2.2.1 PLS to PMA messages

The following messages are sent by the PLS in the DTE or repeater to the PMA in the MAU:

Message	Circuit	Signal	Meaning
output	DO	CD1,CD0	Output information
output_idle	DO	IDL	No data to be output

#### 14.2.2.1.1 PMA to PLS messages

The following messages are sent by the MAU to the PLS in the DTE or repeater:

Message	Circuit	Signal	Meaning
input	DI	CD1,CD0	Input information
input_idle	DI	IDL	No information to input
mau_available	CI	IDL	MAU is available for output
signal_quality_error	CI	CS0	Error detected by MAU

Retiming of CD1 and CD0 signals within the MAU is neither prohibited nor required. Considerable jitter may be present (see 14.3.1.3.1).

#### 14.2.2.2 PMA to twisted-pair link segment messages

Message	Circuit	Signal	Meaning
TD_output	TD	CD1,CD0	Output information
TD_idle	TD	TP_IDL	No information to output

The encoding for TP\_IDL is defined in 14.2.1.1. The encoding for CD1 and CD0 is the same as that used on the AUI. Retiming of CD1 and CD0 signals within the MAU is neither prohibited nor required.

#### 14.2.2.3 Twisted-pair link segment to PMA messages

Message	Circuit	Signal	Meaning
RD_input	RD	CD1,CD0	Input information
RD_idle	RD	TP_IDL	No information to input

The encoding for TP\_IDL is defined in 14.2.1.1. The encoding for CD1 and CD0 is the same as that used on the AUI.

#### 14.2.2.4 Interface message time references

Delay and bit loss specifications are measured from the occurrence of messages at the MDI and MAU AUI. The following describes the point where each message starts:

Message	Reference
output	leading bit cell boundary (BCB) of first valid CD1 or CD0
output_idle	last positive-going transition prior to start of IDL
input	leading BCB of first valid CD1 or CD0
input_idle	last positive-going transition prior to start of IDL
signal_quality_error	first transition of valid amplitude
mau_available	last positive-going transition prior to start of IDL
TD_output	leading BCB of first valid CD1 or CD0
TD_idle	last positive-going transition prior to start of TP_IDL
RD_output	leading BCB of first valid CD1 or CD0
RD_idle	last positive-going transition prior to start of TP_IDL

#### 14.2.3 MAU state diagrams

The state diagrams of Figure 14–3a), Figure 14–3b), Figure 14–4, Figure 14–5, and Figure 14–6 depict the full set of allowed MAU state functions relative to the circuits of the AUI and MDI.

The notation used in the state diagrams follows the conventions in 1.2.1. The variables and timers used in the state diagrams are defined in the following subclauses.

##### 14.2.3.1 State diagram variables

Variables are used in the state diagrams to indicate the status of MAU inputs and outputs, to control MAU operation, and to pass state information between functions.

In the variable definitions, the name of the variable is followed by a brief description of the variable and a list of values the variable may take. For those variables that are state diagram outputs, one value will be identified as the default. The variable has the default value when no active state contains a term assigning a different value.

For example, the variable “xmit” has the value “disable” whenever the Jabber function or the Link Integrity Test function is in a state that asserts “xmit=disable.” The variable has the default value “enable” all other times.

The variables used in the state diagrams are defined as follows:

- DI.** Controls the signal sent by the MAU on the DI circuit.  
 Values: idle; MAU is sending *input\_idle*, IDL (default).  
 DO; MAU sends the signal received on the DO circuit.  
 lpbk = disable overrides this and causes *input\_idle* to be sent.
- RD;** MAU sends the signal received on the RD circuit.  
 rcv = disable overrides this and causes *input\_idle* to be sent.
- CI.** Controls the signal sent by the MAU on the CI circuit.  
 Values: idle; MAU sends *mau\_available*, IDL (default).

SQE; MAU sends *signal\_quality\_error*, CS0.

**DO.** Status of the signal received by the MAU on the DO circuit.

Values: *idle*; MAU is receiving *output\_idle*, IDL.

*active*; MAU is receiving *output*, CD0 or CD1.

**TD.** Controls the signal sent by the MAU on the TD circuit.

Values: *idle*; MAU sends *TD\_idle*, TP\_IDL (default).

DO; MAU sends the signal received on the DO circuit.

*xmit = disable* overrides this and causes *TD\_idle* to be sent.

**RD.** Status of the signal received by the MAU on the RD circuit.

Values: *idle*; MAU is receiving silence or a link test pulse.

*active*; MAU is detecting signals which meet the requirements of 14.3.1.3.2.

**link\_test\_rcv.** Status of the link test signal received by the MAU on the RD circuit.

Values: *false*; MAU is not detecting a link test pulse.

*true*; MAU is detecting a link test pulse.

**link\_count.** Count of the number of consecutive link test pulses received while in the Link Fail state.

Values: non-negative integers.

**lc\_max.** The number of consecutive link test pulses required before exit from the Link Fail state.

Values: positive integer between 2 and 10 inclusive.

**rcv.** Controls the path from the RD circuit to the DI circuit.

Values: *enable*; receive is enabled (default).

*disable*; the output to the DI circuit is *input\_idle* when DI=RD.

**lpbk.** Controls the path from the DO circuit to the DI circuit.

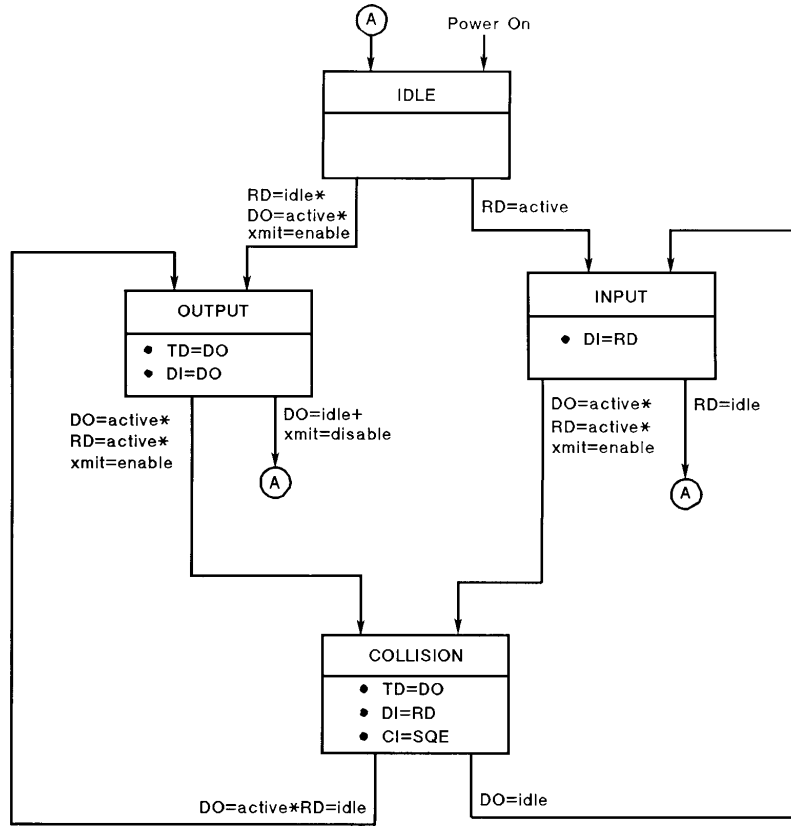
Values: *enable*; loopback is enabled (default).

*disable*; the output to the DI circuit is *input\_idle* when DI=DO.

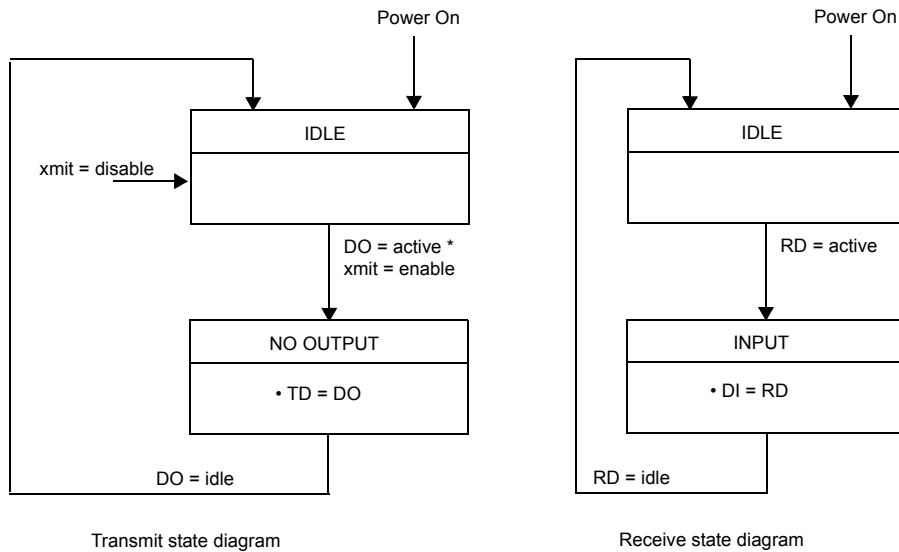
**xmit.** Controls the path from the DO circuit to the TD circuit.

Values: *enable*; transmit is enabled (default).

*disable*; transmit is disabled and the signal sent on the TD circuit is TP\_IDL.



a) MAU Transmit, Receive, Loopback, and Collision Presence functions (half duplex mode)



b) MAU Transmit and Receive functions (full duplex mode)

Figure 14-3—MAU state diagrams

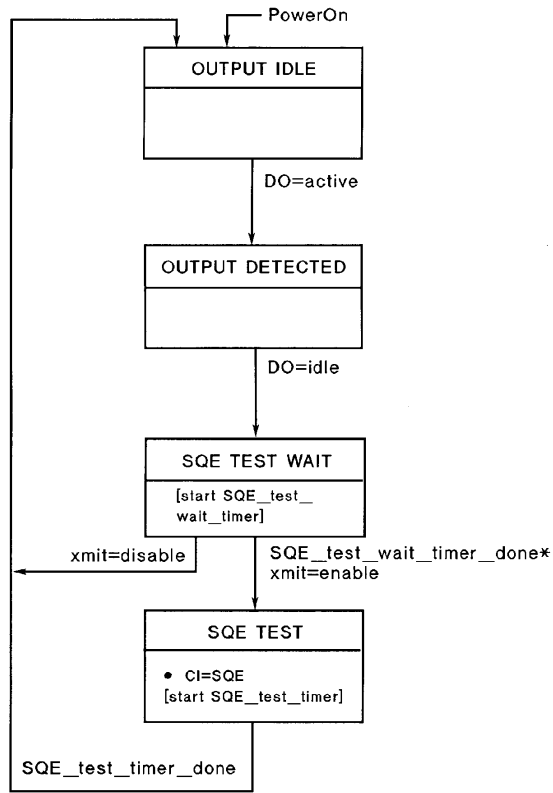
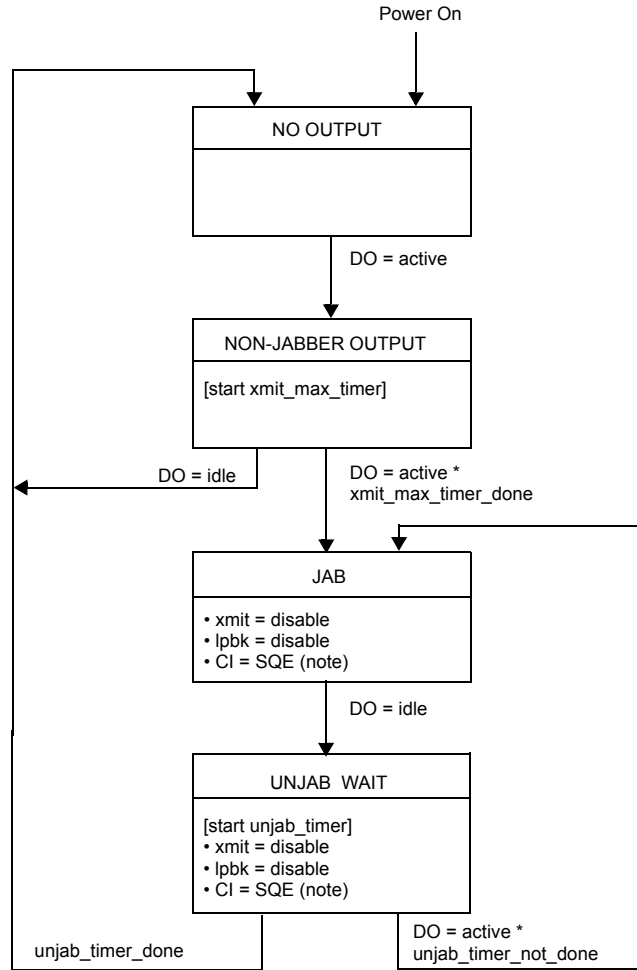


Figure 14–4—`signal_quality_error` Message Test function state diagram



NOTE 1— Sending SQE on CI is optional for MAUs connected to DTEs operating in full duplex mode.

NOTE 2—The implementation of the Collision Presence function is not required in a MAU connected to a full duplex mode DTE, and is not shown in Figure 14–3b).

NOTE 3—The implementation of the SQE Test function shown in Figure 14–4 is not required in a MAU connected to a full duplex mode DTE.

NOTE 4—The enabling of the variable *lpbk* in Figure 14–6 is applicable only in half duplex mode.

**Figure 14–5—Jabber function state diagram**

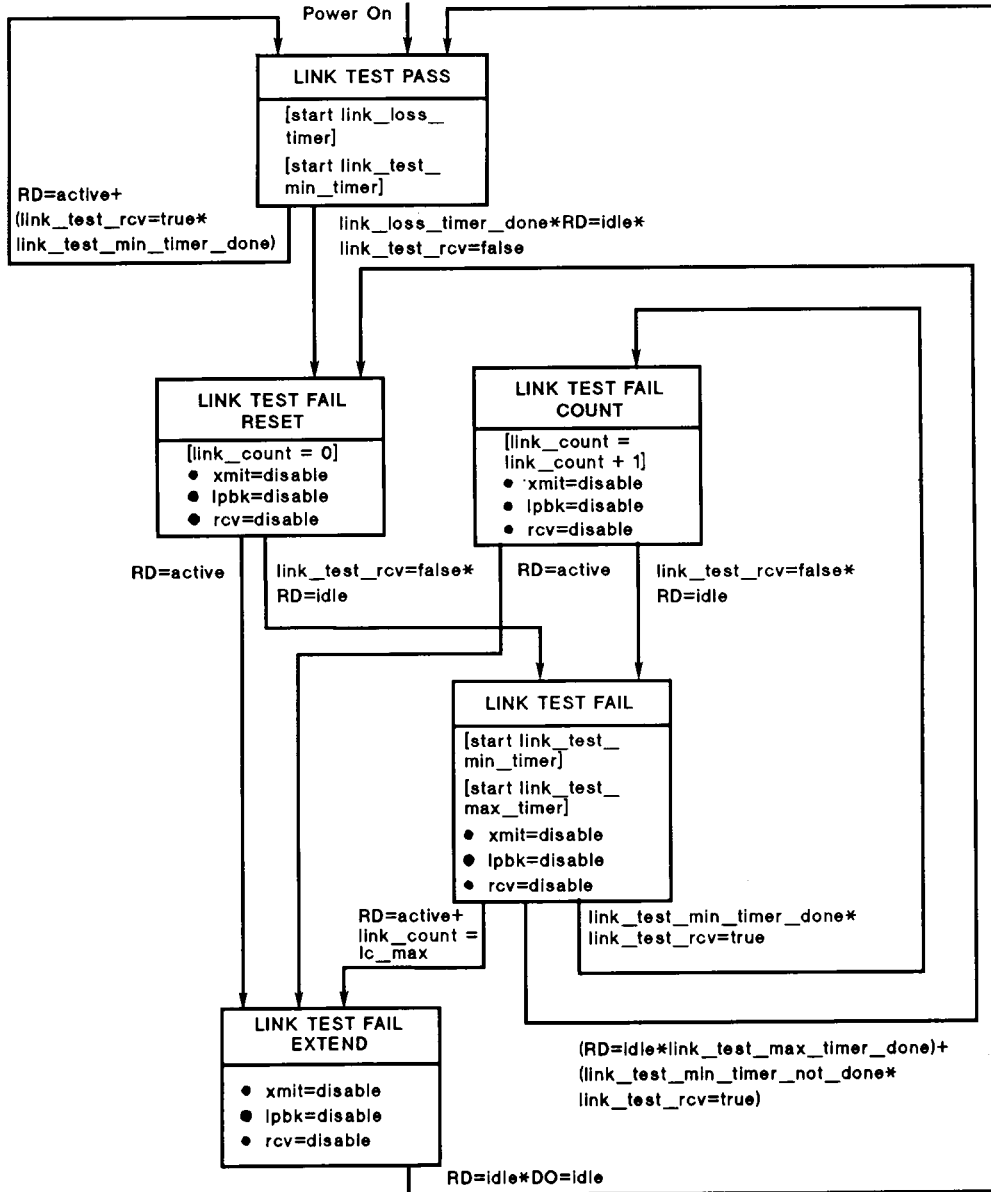


Figure 14-6—Link Integrity Test function state diagram

### 14.2.3.2 State diagram timers

All timers operate in the same fashion. A timer is reset and starts counting upon entering a state where “start x\_timer” is asserted. Time “x” after the timer has been started, “x\_timer\_done” is asserted and remains asserted until the timer is reset. At all other times, “x\_timer\_not\_done” is asserted.

When entering a state where “start x\_timer” is asserted, the timer is reset and restarted even if the entered state is the same as the exited state; for example, when in the Link Test Pass state of the Link Integrity Test function state diagram, the “link\_loss\_timer” and the “link\_test\_min\_timer” are reset each time the term “RD = active + (link\_test\_rcv=true \* link\_test\_min\_timer\_done)” is satisfied.

**link\_loss\_timer.** Timer for longest time input activity can be missing before the MAU determines that a link fail condition exists (14.2.1.7).

**link\_test\_min\_timer.** Timer for the minimum time between valid link test pulses (14.2.1.7).

**link\_test\_max\_timer.** Timer for maximum time input activity can be missing before Link Test Fail state is exited (14.2.1.7).

**SQE\_test\_timer.** Timer for the duration of the CS0 signal used for the SQE Test function (14.2.1.5).

**SQE\_test\_wait\_timer.** Timer for the delay from end of packet to the start of the CS0 signal used for the SQE Test function (14.2.1.5).

**unjab\_timer.** Timer for the length of time the DO circuit must be continuously idle to allow transmission to be re-enabled (14.2.1.6).

**xmit\_max\_timer.** Timer for excessively long transmit time (14.2.1.6).

## 14.3 MAU electrical specifications

This subclause defines the electrical characteristics of the MAU at the MDI and the AUI. The MAU shall also meet the AUI requirements specified in Clause 7 when the AUI is implemented.

Additional information relative to conformance testing is given in B.4.3.

The ground for all common-mode tests is circuit PG, Protective Ground of the AUI. In implementations without an AUI, chassis ground is used as circuit PG. All components in test circuits shall be  $\pm 1\%$  unless otherwise stated.

### 14.3.1 MAU-to-MDI interface characteristics

#### 14.3.1.1 Isolation requirement

A MAU with a MDI that is a PI (see 33.1.3) shall meet the isolation requirements defined in 33.4.1.

A MAU with a MDI that is not a PI shall provide isolation between the DTE Physical Layer circuits including frame ground and all MDI leads including those not used by 10BASE-T.

This electrical isolation shall withstand at least one of the following electrical strength tests.

- a) 1500 V rms at 50 Hz to 60 Hz for 60 s, applied as specified in subclause 5.2.2 of IEC 60950-1:2001.
- b) 2250 V dc for 60 s, applied as specified in subclause 5.2.2 of IEC 60950-1:2001.



- c) A sequence of ten 2400 V impulses of alternating polarity, applied at intervals of not less than 1 s. The shape of the impulses shall be 1.2/50  $\mu$ s (1.2  $\mu$ s virtual front time, 50  $\mu$ s virtual time of half value), as defined in IEC 60950-1:2001 Annex N.

There shall be no insulation breakdown, as defined in subclause 5.2.2 of IEC 60950-1:2001, during the test. The resistance after the test shall be at least 2 M $\Omega$ , measured at 500 V dc.

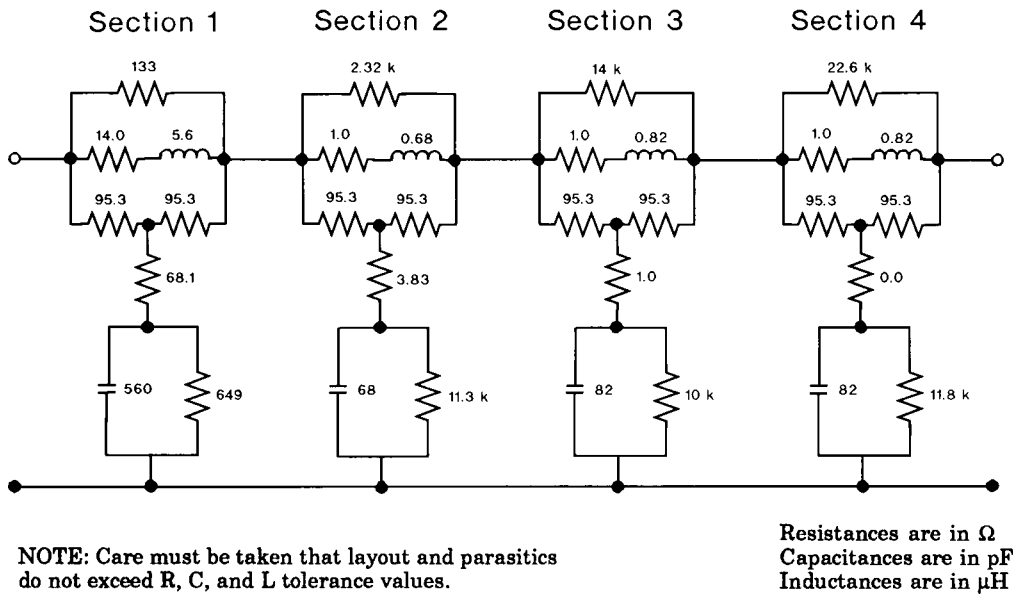
**14.3.1.2 Transmitter specifications**

The MAU shall provide the Transmit function specified in 14.2.1.1 in accordance with the electrical specifications of this subclause.

Where a load is not specified, the transmitter shall meet requirements of this subclause when connected to a 100  $\Omega$  resistive load. The use of 100  $\Omega$  terminations simplifies the measurement process when using 50  $\Omega$  measurement equipment as 50  $\Omega$  to 100  $\Omega$  impedance matching transformers are readily available.

Some tests in this subclause require the use of an equivalent circuit that models the distortion introduced by a simplex link segment. This twisted-pair model shall be constructed according to Figure 14–7 with component tolerances as follows: Resistors,  $\pm$ 1%; capacitors,  $\pm$ 5%; inductors,  $\pm$ 10%. Component tolerance specifications shall be met from 5.0 MHz to 15 MHz. For all measurements, the TD circuit shall be connected through a balun to section 1 and the signal measured across a load connected to section 4 of the model. The balun shall not affect the peak differential output voltage specified in 14.3.1.2.1 by more than 1% when inserted between the 100  $\Omega$  resistive load and the TD circuit.

The insertion loss of the twisted-pair model when measured with a 100  $\Omega$  source and 100  $\Omega$  load shall be between 9.70 dB and 10.45 dB at 10 MHz, and between 6.50 dB and 7.05 dB at 5 MHz.



**Figure 14–7—Twisted-pair model**

**14.3.1.2.1 Differential output voltage**

Some of the text and figures of this subclause describe the differential voltage in terms of magnitudes. These requirements apply to negative as well as positive pulses.

The peak differential voltage on the TD circuit when terminated with a 100 Ω resistive load shall be between 2.2 V and 2.8 V for all data sequences. When the DO circuit is driven by an all-ones Manchester-encoded signal, any harmonic measured on the TD circuit shall be at least 27 dB below the fundamental.

NOTE—The specification on maximum spectral components is not intended to ensure compliance with regulations concerning RF emissions. The implementor should consider any applicable local, national, or international regulations. Additional filtering of spectral components may therefore be necessary.

The output signal  $V_o$ , is defined at the output of the twisted-pair model as shown in Figure 14–8. The TD transmitter shall provide equalization such that the output waveform shall fall within the template shown in Figure 14–9 for all data sequences. Voltage and time coordinates for inflection points on Figure 14–9 are given in Table 14–1. (Zero crossing points are different for external and internal MAUs. The zero crossings depicted in Figure 14–9 apply to an external MAU.) The template voltage may be scaled by a factor of 0.9 to 1.1 but any scaling below 0.9 or above 1.1 shall not be allowed. The recommended measurement procedure is described in B.4.3.1. Time  $t = 0$  on the template represents a zero crossing, with positive slope, of the output waveform. During this test the twisted-pair model shall be terminated in 100 Ω and driven by a transmitter with a Manchester-encoded pseudo-random sequence with a minimum repetition period of 511 bits.

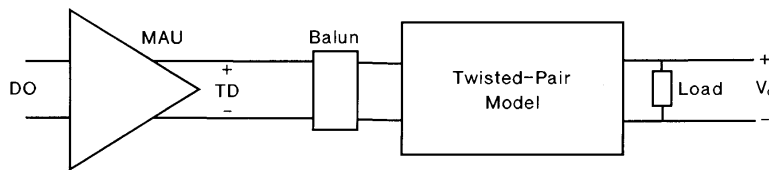


Figure 14–8—Differential output voltage test

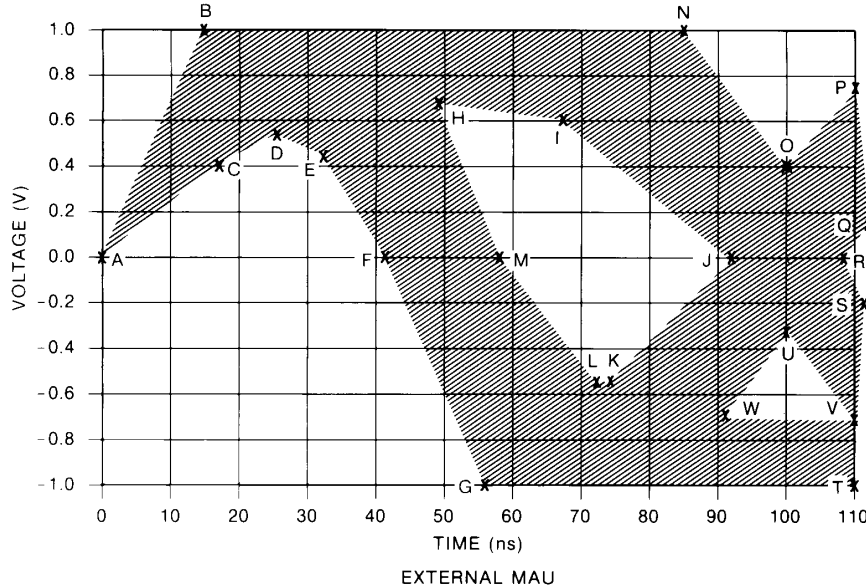


Figure 14–9—Voltage template

Table 14–1—Voltage template values for Figure 14–9

Reference	Time (ns)		Voltage (V)
	External MAU	Internal MAU	
A	0	0	0
B	15	15	1.0
C	15	15	0.4
D	25	25	0.55

**Table 14–1—Voltage template values for Figure 14–9 (continued)**

Reference	Time (ns)		Voltage (V)
	External MAU	Internal MAU	
E	32	32	0.45
F	42	39	0
G	57	57	–1.0
H	48	48	0.7
I	67	67	0.6
J	92	89	0
K	74	74	–0.55
L	73	73	–0.55
M	58	61	0
N	85	85	1.0
O	100	100	0.4
P	110	110	0.75
Q	111	111	0.15
R	108	111	0
S	111	111	–0.15
T	110	110	–1.0
U	100	100	–0.3
V	110	110	–0.7
W	90	90	–0.7

This test shall be repeated with the template inverted about the time axis. In that case,  $t = 0$  on the template represents a zero crossing, with negative slope, of the output waveform. When testing an external MAU the input waveform to the DO circuit of the MAU shall contribute no more than 0.5 ns of jitter. Adherence to this template does not verify that the requirements of 14.3.1.2.3 are met. (See B.4.3.3 for modification of the template to test jitter.)

The TP\_IDL shall always start with a positive waveform when a waveform conforming to Figure 7–12 is applied to the DO circuit. If the last bit transmitted was a CD1, the last transition will be at the bit cell center of the CD1. If the last bit transmitted was a CD0, the PLS will generate an additional transition at the bit cell boundary following the CD0. After the zero crossing of the last transition, the differential voltage shall remain within the shaded area of Figure 14–10. Once the differential voltage has gone more negative than –50 mV, it shall not exceed +50 mV. The template requirements of Figure 14–10 shall be met when measured across each of the test loads defined in Figure 14–11, both with the load connected directly to the TD circuit and with the load connected through the twisted-pair model as defined in Figure 14–7 and Figure 14–8.

The link test pulse shall be a single positive (TD+ lead positive with respect to TD– lead) pulse, which falls within the shaded area of Figure 14–12. Once the differential output voltage has become more negative than –50 mV, it shall remain less than +50 mV. The template requirements of Figure 14–12 shall be met when measured across each of the test loads defined in Figure 14–11; both with the load connected directly to the TD circuit and with the load connected through the twisted-pair model as defined in Figure 14–7 and Figure 14–8.

For a MAU that implements the Auto-Negotiation algorithm defined in Clause 28, the FLP Burst Sequence will consist of multiple link test pulses. All link test pulses in the FLP Burst sequence shall meet the template requirements of Figure 14–12 when measured across each of the test loads defined in Figure 14–11;

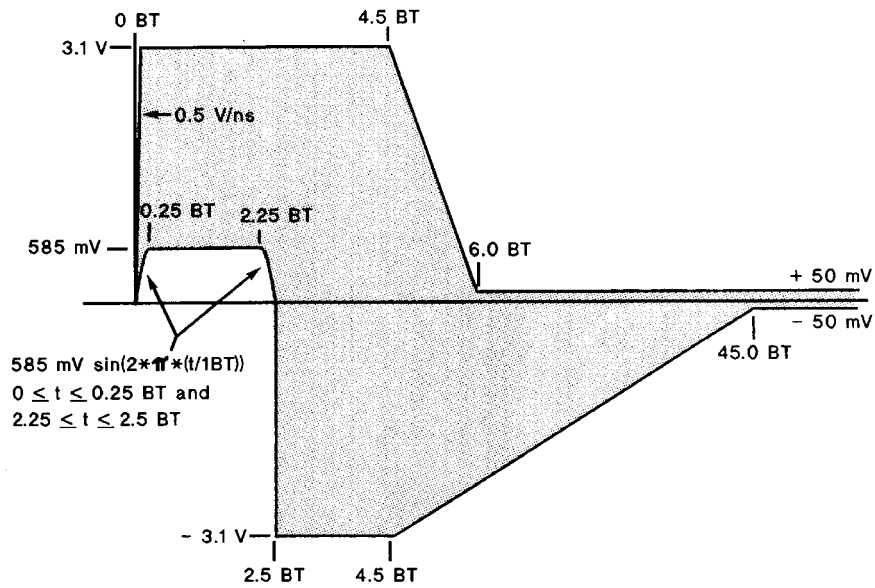
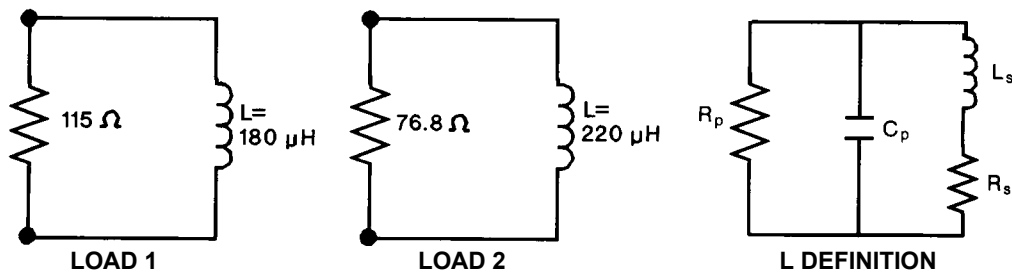


Figure 14-10—Transmitter waveform for start of TP\_IDL



All parameters are defined over the frequency range of 250 kHz to 6 MHz.

$$L_b = L \pm 1\% \quad R_p \geq 2 \text{ k}\Omega$$

$$C_p = 12 \text{ pF} \pm 20\% \quad R_s \leq 0.5 \Omega$$

Figure 14-11—Start-of-TP\_IDL test load

both with the load connected directly to the TD circuit and with the load connected through the twisted-pair model as defined in Figure 14-7 and Figure 14-8.

#### 14.3.1.2.2 Transmitter differential output impedance

The differential output impedance as measured on the TD circuit shall be such that any reflection, due to differential signals incident upon the TD circuit from a simplex link segment having any impedance within the range specified in 14.4.2.2, shall be at least 15 dB below the incident, over the frequency range of 5.0 MHz to 10 MHz. This return loss shall be maintained at all times when the MAU is powered, including when the TD circuit is sending TP\_IDL.

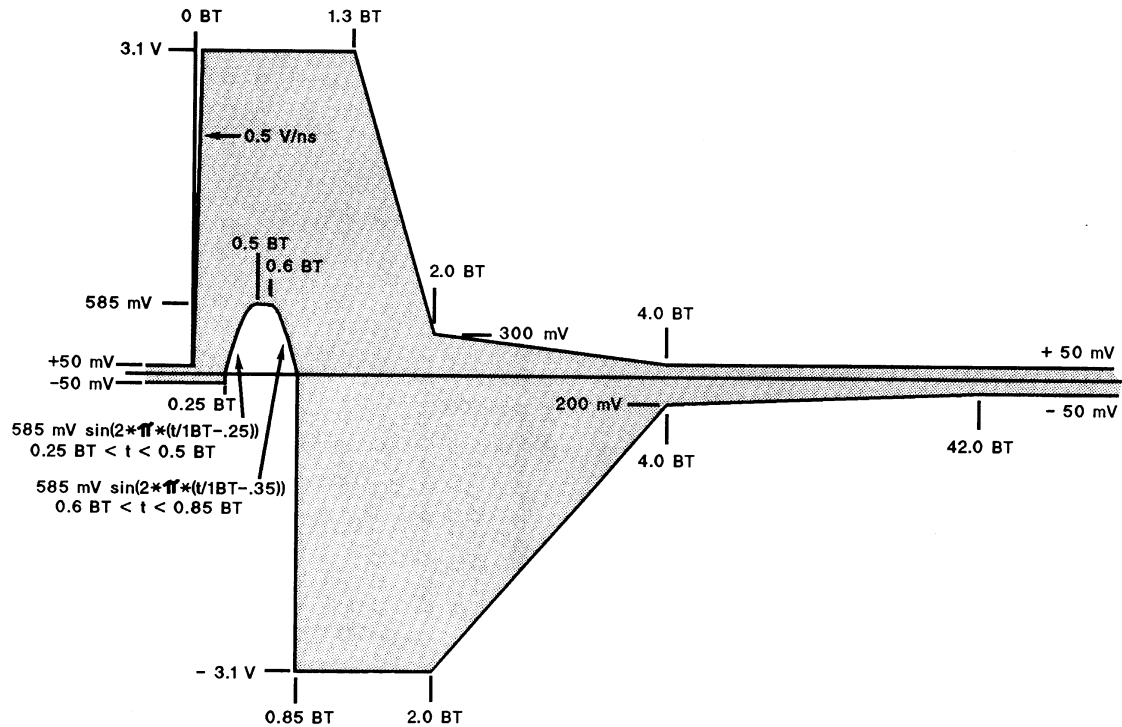


Figure 14-12—Transmitter waveform for link test pulse

#### 14.3.1.2.3 Output timing jitter

The transmitter output jitter is measured at the output of the twisted-pair model terminated in a  $100\ \Omega$  load, as shown in Figure 14-8. The jitter added to the signal on the DO circuit as it propagates through the MAU and the twisted-pair model shall be no more than  $\pm 3.5$  ns. Additionally, the MAU shall add no more than  $\pm 8$  ns of jitter to the signal received on the DO circuit when the TD circuit is directly driving a  $100\ \Omega$  resistive load.

#### 14.3.1.2.4 Transmitter impedance balance

The common-mode to differential-mode impedance balance of the TD circuit shall exceed  $29 - 17 \log_{10}(f/10)$  dB (where  $f$  is the frequency in MHz) over the frequency range 1.0 MHz to 20 MHz. This balance is defined as  $20 \log_{10}(E_{cm}/E_{dif})$ , where  $E_{cm}$  is an externally applied sine wave voltage as shown in Figure 14-13.

NOTE—The balance of the test equipment (such as the matching of the  $147\ \Omega$  resistors) must exceed that required of the transmitter.

#### 14.3.1.2.5 Common-mode output voltage

The magnitude of the total common-mode output voltage of the transmitter,  $E_{cm}$ , measured as shown in Figure 14-14, shall be less than 50 mV peak.

NOTE—This specification is not intended to ensure compliance with regulations concerning RF emissions. The implementor should consider any applicable local, national, or international regulations. Driving unshielded twisted pairs with high-frequency, common-mode voltages may result in interference to other equipment.

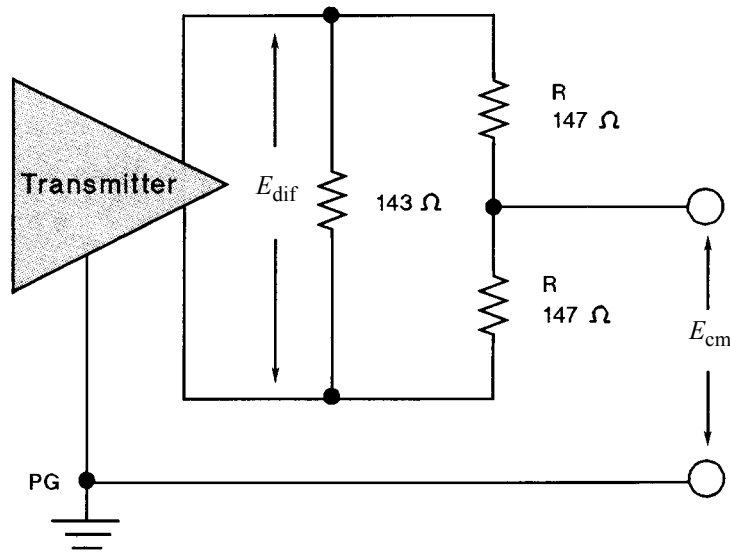


Figure 14-13—Transmitter impedance balance and common-mode rejection test circuit

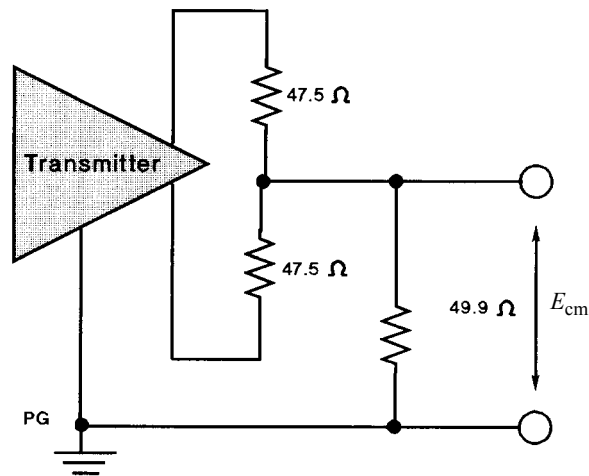


Figure 14-14—Common-mode output voltage test circuit

#### 14.3.1.2.6 Transmitter common-mode rejection

The application of  $E_{cm}$ , as shown in Figure 14-13, shall not change the differential voltage at the TD circuit,  $E_{dif}$ , by more than 100 mV for all data sequences. Additionally, the edge jitter added by the application of  $E_{cm}$  shall be no more than 1.0 ns.  $E_{cm}$  shall be a 15 V peak 10.1 MHz sine wave.

#### 14.3.1.2.7 Transmitter fault tolerance

Transmitters, when either idle or non-idle, shall withstand without damage the application of short circuits across the TD circuit for an indefinite period of time and shall resume normal operation after such faults are removed. The magnitude of the current through such a short circuit shall not exceed 300 mA.

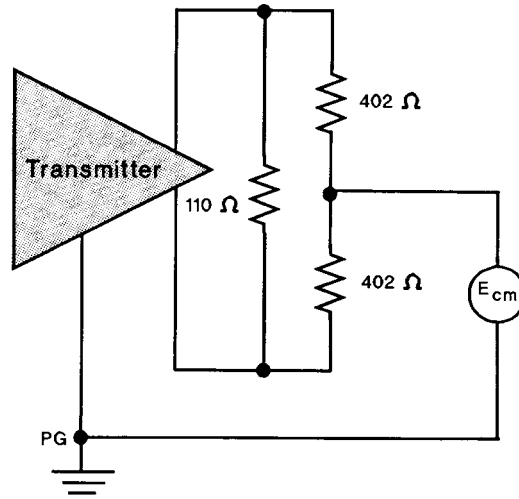


Figure 14–15—Transmitter fault tolerance test circuit

Transmitters, when either idle or non-idle, shall withstand without damage a 1000 V common-mode impulse applied at  $E_{cm}$  of either polarity (as indicated in Figure 14–15). The shape of the impulse shall be 0.3/50  $\mu$ s (300 ns virtual front time, 50  $\mu$ s virtual time of half value), as defined in IEC 60060.

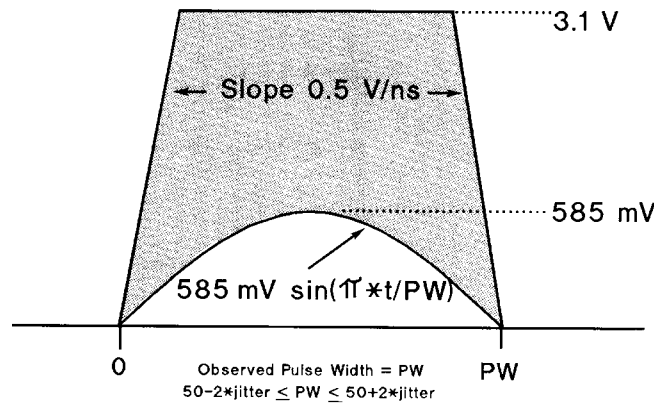


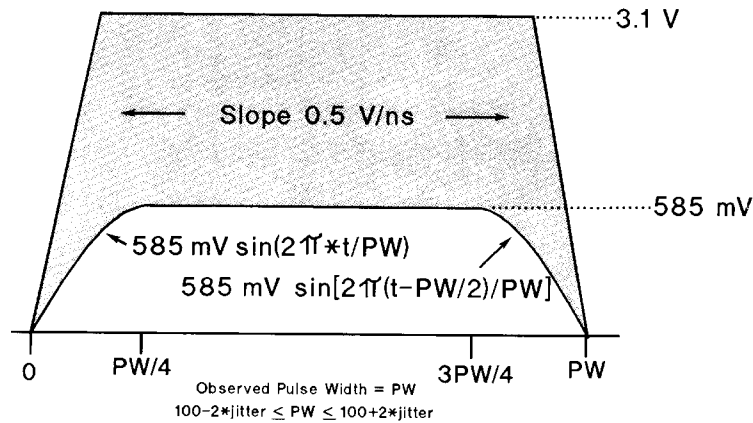
Figure 14–16—Receive differential input voltage—narrow pulse

### 14.3.1.3 Receiver specifications

The MAU shall provide the Receive function specified in 14.2.1.2 in accordance with the electrical specifications of this clause.

#### 14.3.1.3.1 Receiver differential input signals

Differential signals received on the RD circuit that are within the envelope of Figure 14–16 and Figure 14–17, and have a maximum zero crossing jitter up to  $\pm 13.5$  ns from the ideal shall be sent to the DI circuit. The 13.5 ns includes jitter caused by an encoder, AUI cable and transmitting MAU, the twisted pair, and noise. Additionally, the MAU receiver shall add no more than  $\pm 1.5$  ns jitter to the receive signal before sending the signal to the DI circuit.



**Figure 14-17—Receiver differential input voltage—wide pulse**

#### 14.3.1.3.2 Receiver differential noise immunity

The receiver, when presented with Manchester-encoded data meeting the requirements of 14.3.1.3.1, shall send this data to the DI circuit with a bit loss of no more than that specified in 14.2.1.2. In addition, the receiver, when presented with a signal meeting the requirements of 14.2.1.1 and within the envelope of Figure 14-12, shall accept it as a link test pulse.

The receiver, while in the Idle state, shall reject as *RD\_input* the following signals:

- a) All signals that when measured at the output of the following filter would produce a peak magnitude less than 300 mV. The filter is a 3-pole low-pass Butterworth with a 3 dB cutoff at 15 MHz (refer to B.4.2).
- b) All continuous sinusoidal signals of amplitude less than 6.2 V peak-to-peak and frequency less than 2 MHz.
- c) All sine waves of single cycle duration, starting with phase 0 or 180 degrees, and of amplitude less than 6.2 V peak-to-peak where the frequency is between 2 MHz and 15 MHz. For a period of 4 BT before and after this single cycle, the signal shall be less than 300 mV when measured through the filter specified in a) above.

#### 14.3.1.3.3 Idle input behavior

The idle condition shall be detected within 2.3 BT of the last low-to-high transition at the receiver. The receiver shall take precautions to ensure that the high-to-silence transition of the start of idle is not falsely interpreted as a silence-to-non-idle-transition, even in the presence of signal droop, overshoot, ringing, slow voltage decay, or a combination thereof due to capacitive and inductive effects in the transmitter, link segment, and receiver.

#### 14.3.1.3.4 Receiver differential input impedance

The differential input impedance shall be such that any reflection, due to differential signals incident upon the RD circuit from a twisted pair having any impedance within the range specified in 14.4.2.2 shall be at least 15 dB below the incident over the frequency range of 5.0 MHz to 10 MHz. The return loss shall be maintained when the MAU is powered.



### 14.3.1.3.5 Common-mode rejection

Receivers shall assume the proper state on DI for any differential input signal  $E_s$  that results in a signal  $E_{dif}$  that meets 14.3.1.3.1 even in the presence of common-mode voltages  $E_{cm}$  (applied as shown in Figure 14–18).  $E_{cm}$  shall be a 25 V peak-to-peak square wave, 500 kHz or lower in frequency, with edges no slower than 4 ns (20%–80%). Additionally,  $E_{cm}$  shall contribute no more than 2.5 ns of edge jitter to the signal transmitted on the DI circuit. The combination of the receiver timing jitter of 14.3.1.3.1 and the common-mode induced jitter are such that the MAU shall add no more than 4.0 ns of edge jitter to  $E_s$  before sending the signal on the DI circuit.

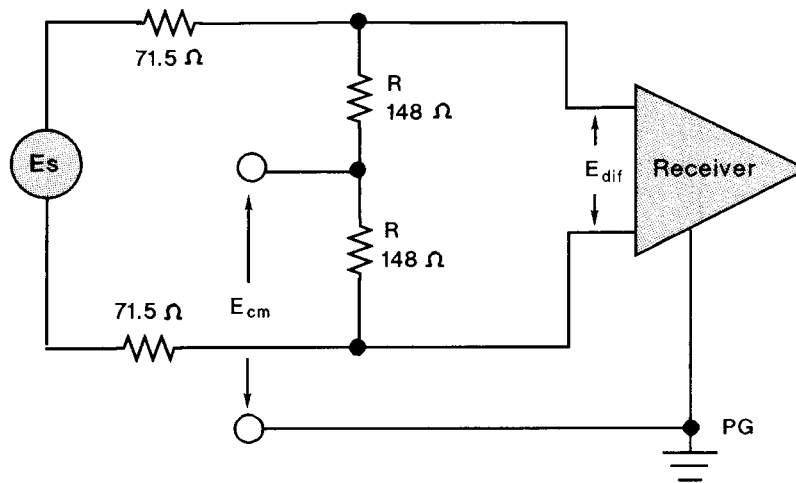


Figure 14–18—Receiver common-mode rejection test circuit

### 14.3.1.3.6 Receiver fault tolerance

The receiver shall tolerate the application of short circuits between the leads of the RD circuit for an indefinite period of time without damage and shall resume normal operation after such faults are removed. Receivers shall withstand without damage a 1000 V common-mode impulse of either polarity ( $E_{impulse}$  as indicated in Figure 14–19). The shape of the impulse shall be 0.3/50  $\mu$ s (300 ns virtual front time, 50  $\mu$ s virtual time of half value), as defined in IEC 60060.

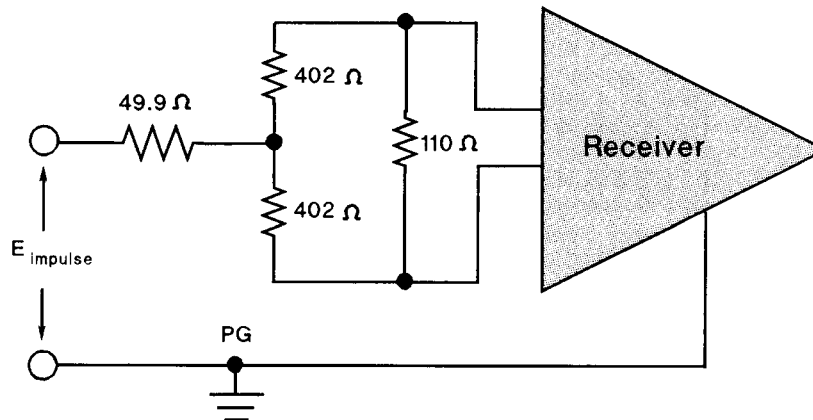


Figure 14–19—Common-mode impulse test circuit

### 14.3.2 MAU-to-AUI specification

When a MAU contains a physical AUI connector, the following specifications shall be met.

#### 14.3.2.1 MAU-AUI electrical characteristics

The electrical characteristics for the driver and receiver components within the MAU that are connected to the AUI shall be identical to those specified in 7.4 and 7.5. Additionally, the AUI DO receiver, while in the Idle state, shall reject an input waveform of less than  $\pm 160$  mV differential.

#### 14.3.2.2 MAU–AUI mechanical connection

The MAU shall be provided with a 15-pin male connector as specified in 7.6.

#### 14.3.2.3 Power consumption

Following PowerOn, the surge current drawn by the MAU shall be such that  $I_p \times T_w$  is less than or equal to  $2 \times 10^{-3}$  ampere-seconds, where  $I_p$  is the peak surge current and  $T_w$  is the time during which the current exceeds the larger of 0.5 A or  $0.5 \times I_p$ . After the 100 ms following PowerOn, the current drawn by the MAU shall not exceed 0.5 A when powered by the AUI.

The MAU shall be capable of operating from all possible voltage sources, including those current limited to 0.5 A, as supplied by the DTE or repeater through the resistance of all permissible AUI cables.

The MAU shall not introduce extraneous signals on the TD, CI, or DI circuits during normal power-up and power-down.

## 14.4 Characteristics of the simplex link segment

Except where otherwise stated, the simplex link segment shall be tested with source and load impedances of 100  $\Omega$ .

### 14.4.1 Overview

The medium for 10BASE-T is twisted-pair wiring. Since a significant number of 10BASE-T networks are expected to be installed utilizing in-place unshielded telephone wiring and typical telephony installation practices, the end-to-end path including different types of wiring, cable connectors, and cross connects must be considered. Typically, a DTE connects to a wall outlet using a twisted-pair patch cord. Wall outlets connect through building wiring and a cross connect to the repeater MAU in a wiring closet.

NOTE—ISO/IEC 11801:2002 provides a specification for media that exceeds the minimum requirements of this standard.

### 14.4.2 Transmission parameters

Each simplex link segment shall have the following characteristics. All characteristics specified apply to the total simplex link segment unless otherwise noted. These characteristics are generally met by 100 m of unshielded twisted-pair cable composed of 0.5 mm [24 AWG] twisted pairs.

#### 14.4.2.1 Insertion loss

The insertion loss of a simplex link segment shall be no more than 11.5 dB at all frequencies between 5.0 and 10 MHz. This consists of the attenuation of the twisted pairs, connector losses, and reflection losses due

to impedance mismatches between the various components of the simplex link segment. The insertion loss specification shall be met when the simplex link segment is terminated in source and load impedances that satisfy 14.3.1.2.2 and 14.3.1.3.4.

NOTE—Multipair PVC-insulated 0.5 mm [24 AWG] cable typically exhibits an attenuation of 8 dB to 10 dB/100 m at 20 °C. The loss of PVC-insulated cable exhibits significant temperature dependence. At temperatures greater than 40 °C, it may be necessary to use a less temperature-dependent cable, such as most plenum-rated cables.

#### 14.4.2.2 Differential characteristic impedance

The magnitude of the differential characteristic impedance of a 3 m length of twisted pair used in a simplex link segment shall be between 85  $\Omega$  and 111  $\Omega$  for all frequencies between 5.0 MHz and 10 MHz. Since characteristic impedance tends to decrease with increasing frequency, the above requirement is generally implied by the condition that the magnitude of the characteristic impedance over the frequency band 1 MHz to 16 MHz is 100  $\Omega \pm 15 \Omega$ . Also, the magnitude of the input impedance averaged over the 5.0 MHz to 10 MHz frequency band of a simplex link segment terminated in 100  $\Omega$  shall be between 85  $\Omega$  and 111  $\Omega$ .

#### 14.4.2.3 Medium timing jitter

Intersymbol interference and reflections due to impedance mismatches between tandem twisted pairs of a twisted-pair link segment and effects of connection devices can introduce jitter to the CD1 and CD0 signals received on the RD circuit. No more than  $\pm 5.0$  ns of jitter shall be introduced to a test signal by a simplex link segment. The test signal shall have a peak amplitude of 3.0 V and 10% to 90% rise and fall times of 12 ns. The content of the test signal shall be a Manchester-encoded pseudo-random sequence with a minimum repetition period of 511 bits.

NOTE—Branches off a twisted pair (often referred to as “bridged taps” or “stubs”) will generally cause excessive jitter and so should be avoided.

#### 14.4.2.4 Delay

The maximum propagation delay of twisted pair shall be 5.7 ns/m (minimum velocity of  $0.585 \times c$ ). The maximum propagation delay of a link segment shall not exceed 1000 ns.

### 14.4.3 Coupling parameters

To avoid excessive coupling of signals between twisted pairs of a twisted-pair cable, the crosstalk must be limited. Crosstalk loss is specified for the twisted pairs in a twisted-pair cable or twisted-pair cable binder group that are used as 10BASE-T twisted-pair links. Crosstalk loss is specified with the far ends of both the disturbed and the disturbing pairs and the near end of the disturbed pair terminated in 100  $\Omega$ . Drivers of disturbing pairs shall have a source impedance of 100  $\Omega$ .

#### 14.4.3.1 Differential near-end crosstalk (NEXT) loss

The NEXT loss between any two twisted pairs of a twisted-pair cable is dependent upon the geometry of the twisted-pair cable. Since the proximity of any two twisted pairs is influenced by the size of the twisted-pair cable, the NEXT loss is affected by twisted-pair cable size.

##### 14.4.3.1.1 Twenty-five-pair cable and twenty-five-pair binder groups

The NEXT loss between any two twisted pairs in a twenty-five-pair twisted-pair cable or binder group used for 10BASE-T applications shall be at least  $30 - 15 \log_{10}(f/10)$  dB (where  $f$  is the frequency in MHz) over the frequency range 5.0 MHz and 10 MHz.

#### 14.4.3.1.2 Four-pair cable

The NEXT loss between any two twisted pairs in a four-pair twisted-pair cable used for 10BASE-T applications shall be at least  $26 - 15 \log_{10}(f/10)$  dB (where  $f$  is the frequency in MHz) over the frequency range 5.0 MHz and 10 MHz.

#### 14.4.3.1.3 Other cables

The NEXT loss requirement for all other twisted-pair cables shall be the multiple-disturber NEXT loss of 14.4.3.2.

#### 14.4.3.2 Multiple-disturber NEXT (MDNEXT) loss

When a twisted-pair cable or twisted-pair cable binder group contains twisted pairs from multiple 10BASE-T twisted-pair link segments, the multiple-disturber crosstalk loss is dependent upon the specific selection of disturbing and disturbed pairs. For each 10BASE-T receive pair, MDNEXT is measured by having the remaining near-end transmit pairs (excluding the transmit pair associated with the receive pair under test) driven with identical and synchronized sine wave signals. MDNEXT may then be determined from the signal level observed on the receive pair under test. By examining all pair combinations with a fixed number of disturbers, a cumulative distribution of MDNEXT is obtained at each frequency of interest. The one percentile of this cumulative distribution shall be at least  $23 - 15 \log_{10}(f/10)$  (where  $f$  is the frequency in MHz) at 5.0 MHz, 7.5 MHz, and 10 MHz. When the number of possible combinations allowed by a cable is fewer than 100, the MDNEXT loss for all combinations shall be at least  $23 - 15 \log_{10}(f/10)$  (where  $f$  is the frequency in MHz) at 5.0 MHz, 7.5 MHz, and 10 MHz. Refer to 12.7.3.2 and B.3 for a tutorial and method for estimating the MDNEXT loss for a complete  $n$ -pair cable.

#### 14.4.4 Noise environment

The noise level on the link segments shall be such that the objective error ratio is met. The noise environment consists generally of two primary contributors: crosstalk from other 10BASE-T circuits; and externally induced impulse noise, typically from telephone ringing and dialing signals, and other office and building equipment.

##### 14.4.4.1 Impulse noise

The average rate of occurrence of impulses greater than 264 mV shall be less than or equal to 0.2/s as measured at the output of the following specified filter. Following the start of any particular impulse that is counted, any additional impulse shall be ignored for a period of 1  $\mu$ s. The simplex link segment shall be terminated at the far end in 100  $\Omega$ . The filter is a 3-pole Butterworth low-pass with a 3 dB cutoff at 15 MHz (refer to B.4.2).

NOTE—Typically, the impulse noise occurrence rate changes inversely by one decade for each 5 dB to 9 dB change in the threshold voltage. If a count rate of  $N$  counts/s is measured on a specific twisted pair and filter at the specified voltage threshold, the media noise margin is approximately  $7 \log_{10}(0.2/N)$  dB. Impulse noise may be a burst phenomenon and should be measured over an extended period of time.

##### 14.4.4.2 Crosstalk noise

The level of crosstalk noise on a simplex link segment depends on the level of the disturbing signal(s) and the crosstalk loss between the pair(s) carrying the signal(s) and the disturbed pair. With the maximum transmit level (14.3.1.2), the sinusoidal crosstalk loss (14.4.3.2), and multiple, random Manchester-encoded disturbers, the peak self-crosstalk noise levels as measured at the output of the following specified filter shall be less than or equal to 264 mV. The filter is a 3-pole Butterworth low-pass with a 3 dB cutoff at 15 MHz (refer to B.4.2).

## 14.5 MDI specification

This subclause defines the MDI for the twisted-pair link segment. The link topology requires a crossover function between PMAs. Implementation and location of this crossover is also defined in this clause.

### 14.5.1 MDI connectors

Eight-pin connectors meeting the requirements of Clause 3 and Figures 1 through 5 of IEC 60603-7 shall be used as the mechanical interface to the twisted-pair link segment. The plug connector shall be used on the twisted-pair link segment and the jack on the MAU. These connectors are depicted (for informational use only) in Figure 14–20 and Figure 14–21. The following table shows the assignment of signals to connector contacts.

Contact	MDI signal
1	TD+
2	TD–
3	RD+
4	Not used by 10BASE-T
5	Not used by 10BASE-T
6	RD–
7	Not used by 10BASE-T
8	Not used by 10BASE-T

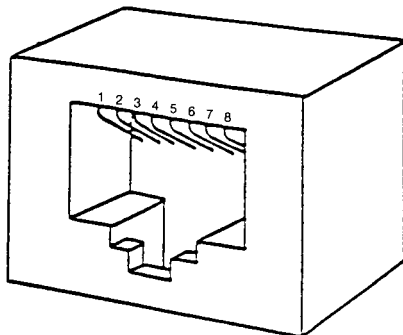


Figure 14–20—MAU MDI connect

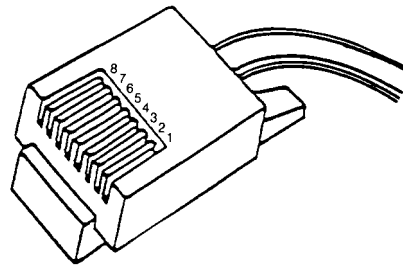
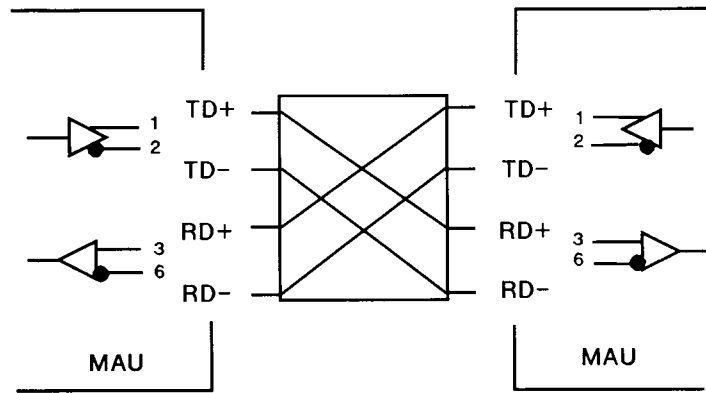


Figure 14–21—Twisted-pair link segment connector

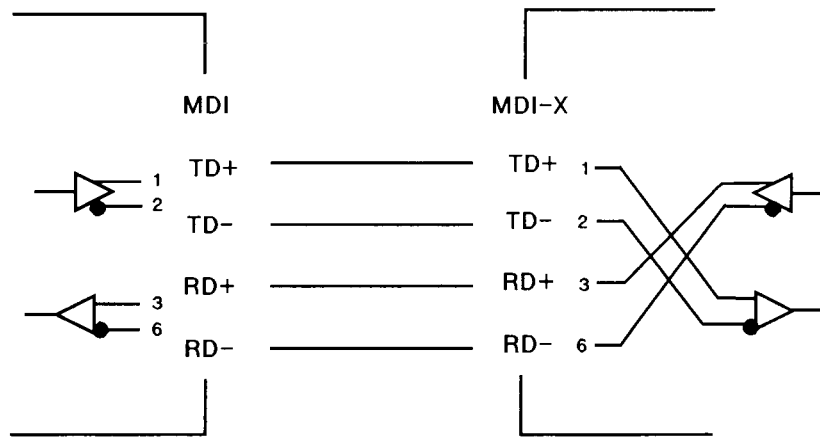
### 14.5.2 Crossover function

A crossover function shall be implemented in every twisted-pair link. The crossover function connects the transmitter of one MAU to the receiver of the MAU at the other end of the twisted-pair link. Crossover functions may be implemented internally to a MAU or elsewhere in the twisted-pair link. For MAUs that do not implement the crossover function, the signal names of 14.5.1 refer to their own internal circuits. For MAUs that do implement the crossover function, the signal names refer to the remote MAU of the twisted-pair link. Additionally, the MDI connector for a MAU that implements the crossover function shall be marked with the graphical symbol “X”. Internal and external crossover functions are shown in Figure 14–22.

When a twisted-pair link connects a DTE to a repeater, it is recommended that the crossover be implemented in the MAU local to the repeater. If both MAUs of a twisted-pair link contain internal crossover functions,



a) External Crossover function



b) MAU-Embedded Crossover function

Figure 14–22—Crossover function

an additional external crossover is necessary. It is recommended that the crossover be visible to an installer from one of the MAUs. When both MAUs contain internal crossovers, it is further recommended in networks in which the topology identifies either a central backbone segment or a central hub that the MAU furthest from the central element be assigned the external crossover to maintain consistency.

Implicit implementation of the crossover function within a twisted-pair cable, or at a wiring panel, while not expressly forbidden, is beyond the scope of this standard.

## 14.6 System considerations

The repeater unit specified in Clause 9 forms the central unit for interconnecting 10BASE-T twisted-pair links in networks of more than two nodes. It also provides the means for connecting 10BASE-T twisted-pair links to other 10 Mb/s baseband segments. The proper operation of a CSMA/CD network requires network size to be limited to control round-trip propagation delay to meet the requirements of 4.2.3.2.3 and 4.4.2, and the number of repeaters between any two DTEs to be limited in order to limit the shrinkage of the inter-

packet gap as it travels through the network. Configuration rules, which ensure that these limits are not exceeded, are given in Clause 13.

## 14.7 Environmental specifications

### 14.7.1 General safety

All equipment meeting this standard shall conform to IEC 60950:1991.

### 14.7.2 Network safety

This subclause sets forth a number of recommendations and guidelines related to safety concerns; the list is neither complete nor does it address all possible safety issues. The designer is urged to consult the relevant local, national, and international safety regulations to ensure compliance with the appropriate requirements.

LAN cable systems described in this subclause are subject to at least four direct electrical safety hazards during their installation and use. These hazards are as follows:

- a) Direct contact between LAN components and power, lighting, or communications circuits.
- b) Static charge buildup on LAN cables and components.
- c) High-energy transients coupled onto the LAN cable system.
- d) Voltage potential differences between safety grounds to which various LAN components are connected.

Such electrical safety hazards must be avoided or appropriately protected against for proper network installation and performance. In addition to provisions for proper handling of these conditions in an operational system, special measures must be taken to ensure that the intended safety features are not negated during installation of a new network or during modification or maintenance of an existing network. Isolation requirements are defined in 14.3.1.1.

#### 14.7.2.1 Installation

Sound installation practice, as defined by applicable local codes and regulations, shall be followed in every instance in which such practice is applicable.

#### 14.7.2.2 Grounding

Any safety grounding path for the MAU shall be provided through the circuit PG of the AUI connection.

#### **WARNING**

It is assumed that the equipment to which the MAU is attached is properly earthed, and not left floating nor serviced by a “doubly insulated ac power distribution system.” The use of floating or insulated equipment, and the consequent implications for safety are beyond the scope of this standard.

#### 14.7.2.3 Installation and maintenance guidelines

During installation and maintenance of the cable plant, care shall be taken to ensure that uninsulated network cable conductors do not make electrical contact with unintended conductors or ground.

#### **14.7.2.4 Telephony voltages**

The use of building wiring brings with it the possibility of wiring errors that may connect telephony voltages to 10BASE-T equipment. Other than voice signals (which are low voltage), the primary voltages that may be encountered are the “battery” and ringing voltages. Although there is no universal standard, the following maximums generally apply.

Battery voltage to a telephone line is generally 56 Vdc applied to the line through a balanced 400  $\Omega$  source impedance.

Ringing voltage is a composite signal consisting of an ac component and a dc component. The ac component is up to 175 V peak at 20 Hz to 60 Hz with a 100  $\Omega$  source resistance. The dc component is 56 Vdc with a 300  $\Omega$  to 600  $\Omega$  source resistance. Large reactive transients can occur at the start and end of each ring interval.

Although 10BASE-T equipment is not required to survive such wiring hazards without damage, application of any of the above voltages shall not result in any safety hazard.

NOTE—Wiring errors may impose telephony voltages differentially across 10BASE-T transmitters or receivers. Because the termination resistance likely to be present across a receiver’s input is of substantially lower impedance than an off-hook telephone instrument, receivers will generally appear to the telephone system as off-hook telephones. Therefore, full-ring voltages will be applied for only short periods. Transmitters that are coupled using transformers will similarly appear like off-hook telephones (though perhaps a bit more slowly) due to the low resistance of the transformer coil.

### **14.7.3 Environment**

#### **14.7.3.1 Electromagnetic emission**

The twisted-pair link shall comply with applicable local and national codes for the limitation of electromagnetic interference.

#### **14.7.3.2 Temperature and humidity**

The twisted-pair link is expected to operate over a reasonable range of environmental conditions related to temperature, humidity, and physical handling (such as shock and vibration). Specific requirements and values for these parameters are considered to be beyond the scope of this standard.

It is recommended that manufacturers indicate in the literature associated with the MAU the operating environmental conditions to facilitate selection, installation, and maintenance.

It is recommended that manufacturers indicate, in the literature associated with the components of the twisted-pair link segment, the distance and operating environmental conditions over which the specifications of 14.4 will be met.

### **14.8 MAU labeling**

It is recommended that each MAU (and supporting documentation) be labeled in a manner visible to the user with at least these parameters:

- a) Data rate capability in Mb/s,
- b) Power level in terms of maximum current drain (for external MAUs),
- c) Any applicable safety warnings, and
- d) Duplex capabilities.



See also 14.5.2.

## 14.9 Timing summary

Table 14–2 summarizes the timing requirements for the 10BASE-T twisted-pair link. This table is a summary; for complete descriptions of the timing requirements, refer to the referenced subclauses.

**Table 14–2—Maximum timing parameters**

Symbol	Function	Bit loss <sup>a</sup>	Invalid bits <sup>b</sup>	Steady-state propagation delay <sup>b</sup>	Start-up delay <sup>b</sup>		Specified in
					Maximum	Variability	
M1	<i>RD_input</i> to <i>input</i> on DI	5.0	1.0	2.0	8.0	2.0	14.2.1.2
M2	<i>output</i> on DO to <i>TD_output</i>	2.0	1.0	2.0	5.0	2.0	14.2.1.1
M3	<i>RD_input</i> * <i>output</i> to <i>signal_quality_error</i>	—	—	—	9.0	—	14.2.1.4
M4	<i>RD_idle</i> + <i>output_idle</i> (end of collision) to <i>mau_available</i>	—	—	—	9.0	—	14.2.1.4
M5	<i>RD_input</i> * <i>output</i> to <i>input</i> on DI from circuit RD	—	—	—	9.0	—	14.2.1.4
M6	<i>RD_idle</i> * <i>output</i> to <i>input</i> on DI from circuit DO	—	—	—	9.0	—	14.2.1.4
M7	<i>output_idle</i> on DO to <i>signal_quality_error</i>	—	—	—	6 < x < 16	—	14.2.1.5
M8	<i>signal_quality_error</i> duration for SQE test	—	—	—	5 < x < 15	—	14.2.1.5
M9	<i>output</i> on DO to <i>input</i> on DI	5.0	1.0	1.0	7.0	—	14.2.1.3
T1	twisted-pair propagation	0	0	10.00	10.00	—	14.4.2.4
A1	AUI cable propagation (50 m)	0	0	2.57	2.57	—	7.4.3.7

<sup>a</sup>All time in BT.

<sup>b</sup>For an explanation of the meaning of variability, see 14.2.1.1 and 14.2.1.2.

## **14.10 Protocol implementation conformance statement (PICS) proforma for Clause 14, Twisted-pair medium attachment unit (MAU) and baseband medium, type 10BASE-T<sup>31</sup>**

### **14.10.1 Introduction**

To evaluate conformance of a particular implementation, it is necessary to state which capabilities and options have been implemented for a given OSI protocol. Such a statement is called a protocol implementation conformance statement (PICS).

This PICS proforma defines conformance requirements for type 10BASE-T MAU implementations. When the supplier completes this proforma, this document becomes the PICS for the specified implementation. The PICS is then used to perform a static conformance review of the implementation to determine that all mandatory features are implemented and that all conditional features are correctly supported dependent on the options claimed to be implemented. The PICS is used also as an aid in test-case selection and result analysis during the dynamic conformance testing.

Separate MAU and link segment implementations are expected; submissions of either for testing do not require submission of the other. Furthermore, there is no current intention to produce an Abstract Test Suite from the subclause of the PICS proforma that discusses the link segment.

#### **14.10.1.1 Scope**

This subclause provides the PICS proforma for type 10BASE-T MAU specifications in accordance with the relevant guidance given in ISO/IEC 9646-2.

#### **14.10.1.2 Reference**

Type 10BASE-T MAU requirements referenced in this PICS proforma are found in 14.2 through 14.8 and in 7.3 through 7.6 of this standard. Subclauses 7.3 through 7.6 and 14.2 through 14.8 take precedence over 14.10 in case of any conflict.

The use and the requirements for PICS proforma are defined in ISO/IEC 9646-1 and ISO/IEC 9646-2.

#### **14.10.1.3 Definitions**

This document uses the following terms defined in ISO/IEC 9646-1:

- PICS proforma
- protocol implementation conformance statement (PICS)
- static conformance review
- dynamic conformance testing

#### **14.10.1.4 Conformance**

The supplier of a MAU that is claimed to conform to type 10BASE-T MAU specifications shall complete a copy of the PICS proforma provided in this document and shall provide the information necessary to identify both the supplier and the implementation.

---

<sup>31</sup>*Copyright release for PICS proformas:* Users of this standard may freely reproduce the PICS proforma in this subclause so that it can be used for its intended purpose and may further publish the completed PICS.

**14.10.2 Identification of implementation**

The MAU supplier shall complete the relevant fields in this subclause to identify the supplier and the particular MAU.

**14.10.2.1 Supplier information**

The MAU supplier shall complete the relevant fields in this subclause to identify the supplier and the particular MAU.

Company name:	
Representative name:	
Address:	
Phone:	
Fax:	
E-mail:	

**14.10.2.2 Implementation information**

Implementation name:	
Implementation identifier (including version/release):	

**14.10.3 Identification of the protocol**

The supplier will complete this subclause to identify the precise protocol implemented.

Check Y [ ] if the MAU identified in the previous subclause implements the following protocol standard; check N [ ] if otherwise and attach an explanation.

IEEE Std 802.3-2008, Clause 14, Twisted-pair medium attachment unit (MAU) and baseband medium, type 10BASE-T	Y [ ]	N [ ]
--	-------	-------

List any other addenda or amendment documents implemented.

## 14.10.4 PICS proforma for 10BASE-T

### 14.10.4.1 Abbreviations

The following abbreviations are used in the PICS proforma tables:

Req=Requirement. This column indicates whether the conformance requirement of a particular clause in the standard is mandatory, optional, or conditional.

Imp=Implementation. This column is filled in for a particular implementation with a “Y” or an “N” to indicate claimed conformance.

M=Mandatory. Conformance cannot be met unless the parameter is implemented as specified.

O=Optional. The parameter may be implemented or not but, if implemented, it must be as stated in the standard.

C=Conditional. If an associated major option is implemented, this parameter must be implemented.

NOTE—Recommendations in the standard become “Optional” parameters in the context of a PICS proforma.

### 14.10.4.2 PICS Completion instructions and implementation statement

A supplier wishing to submit a 10BASE-T MAU for conformance testing against this standard must fill in the column headed “Imp” in the PICS proforma tables and submit the resulting PICS with the equipment for test. This column must be filled in either with a “Y” for yes, indicating that the implementation is intended to meet the particular mandatory or optional requirement, or “N” for no, indicating that the option has not been implemented (or enabled where switchable) or that the requirement is not met. It should be noted that any instances of “N” entered against a mandatory requirement will result in the implementation failing the static conformance test. In addition, the supplier must indicate below whether or not the implementation implements all the mandatory requirements.

This implementation implements all mandatory requirements	Y [ ]	N [ ]
---	-------	-------

### 14.10.4.3 Additional information

Any additional information that is needed to ensure that the MAU or link segment submitted for test is configured as a 10BASE-T MAU or link segment should be entered into the PIXIT (Protocol Implementation eXtra Information for Testing) document supplied by the conformance testing organization. Relevant information on 10BASE-T MAUs or link segments includes the following:

- a) Enable/disable mechanisms for SQE Test
- b) Enable/disable mechanisms for features that allow compatibility with nonstandard implementations
- c) Operational instructions for DTEs or repeaters in cases where the MAU is embedded
- d) Environmental conditions
- e) Input voltage range for implementations with embedded MAUs

The above list is illustrative and is not intended to be either mandatory or exhaustive.

### 14.10.4.4 References

ISO/IEC 9646-2 requires that all PICS proforma clauses be individually identified. Tables have subclause headings and numbered clauses in order to meet this requirement.

**14.10.4.5 PICS proforma tables for MAU****14.10.4.5.1 MAU functions**

	Parameter	Subclause	Req	Imp	Value/Comment
	MAU functions:	14.2.1			
MF1	Transmit		M		
MF2	Receive		M		
MF3	Loopback		C		Function performed by MAUs attached to half duplex mode DTEs and repeaters, not performed by MAUs attached to full duplex mode DTEs.
MF4	Collision Presence		C		Function performed by MAUs attached to half duplex mode DTEs and repeaters, optionally performed by MAUs attached to full duplex mode DTEs that fully support this option as described in 14.2.1.
MF5	Jabber		M		
MF6	Link Integrity Test		M		
MF7	SQE Test		C		Function performed by MAUs attached to half duplex DTEs, optionally performed by MAUs attached to full duplex DTEs that fully support this option as described in 14.2.1, not performed by MAUs attached to repeaters.
MF8	Auto-Negotiation		C		Function provided by MAUs implementing the Auto-Negotiation algorithm, as defined in Clause 28.

#### 14.10.4.5.2 Transmit function

	Parameter	Subclause	Req	Imp	Value/Comment
TF1	Transmit path	14.2.1.1	M		DO circuit to TD circuit
TF2	Transmit signal polarity	14.2.1.1	M		DO A positive relative to DO B causes TD+ positive relative to TD-
TF3	Start-up bit loss (DO to TD circuits)	14.2.1.1	M		2 bits max
TF4	Transmit settling time	14.2.1.1	M		Second and following bits meet amplitude and jitter specifications
TF5	Transmit steady-state delay	14.2.1.1	M		2 bit times max
TF6	Transmit delay variability	14.2.1.1	M		2 bit times max
TF7	TP_IDL	14.2.1.1	M		Start of idle followed by a repeating sequence of silence and link test pulse
TF8	Silence duration	14.2.1.1	M		16 ms $\pm$ 8 ms, $\leq$ $\pm$ 50 mV
TF9	TP_IDL termination with respect to start of packet	14.2.1.1	M		Normal start of packet requirements apply

#### 14.10.4.5.3 Receive function

	Parameter	Subclause	Req	Imp	Value/Comment
RF1	Receive path	14.2.1.2	M		RD circuit to DI circuit
RF2	Receive signal polarity	14.2.1.2	M		RD+ positive relative to RD- causes DI A positive relative to DI B
RF3	Start-up bit loss (RD to DI circuits)	14.2.1.2	M		5 bits max
RF4	Receive settling time	14.2.1.2	M		Second and following bits meet jitter specifications
RF5	Receive steady-state delay	14.2.1.2	M		2 bit times max
RF6	Receive delay variability	14.2.1.2	M		2 bit times max

**14.10.4.5.4 Loopback function**

The following are conditional based on whether the Loopback function is to be performed (14.10.4.5.1, item MF3).

	Parameter	Subclause	Req	Imp	Value/Comment
BF1	Loopback function requirements when RD = idle and DO = active	14.2.1.3	C		DO signals to DI circuit
BF2	Loopback bit loss (DO to DI circuits)	14.2.1.3	C		5 bits max
BF3	Loopback settling time	14.2.1.3	C		Second and following bits meet jitter specifications
BF4	Loopback steady-state delay	14.2.1.3	C		1 bit time max

**14.10.4.5.5 Collision Detect function**

The following are conditional based on whether the Collision Presence function is to be performed (14.10.4.5.1, item MF4).

	Parameter	Subclause	Req	Imp	Value/Comment
CF1	Collision Presence function requirements	14.2.1.4	C		CS0 on CI circuit if DO=active, RD=active and in Link Test Pass state
CF2	Collision indication delay	14.2.1.4	C		9 bit times max
CF3	Collision indicate de-assert delay	14.2.1.4	C		9 bit times max
CF4	CI circuit with no collision, SQE Test, or jabber	14.2.1.4	C		IDL signal
CF5	DI circuit source switch delay from CS0 assert	14.2.1.4	C		9 bit times max
CF6	DI circuit source switch delay from CS0 de-assert	14.2.1.4	C		9 bit times max

#### 14.10.4.5.6 *signal\_quality\_error* Message Test function

The following are conditional based on whether the *signal\_quality\_error* Message Test is to be performed (14.10.4.5.1, item MF7).

	Parameter	Subclause	Req	Imp	Value/Comment
SF1	SQE Test induced TD or DI circuit signals	14.2.1.5	C		No extraneous signals permitted
SF2	SQE_test_wait timer range	14.2.1.5	C		0.6 to 1.6 $\mu$ s
SF3	SQE_test timer range	14.2.1.5	C		5 to 15 bit times
SF4	CI circuit during SQE Test	14.2.1.5	C		CS0 signal
SF5	SQE Test in Link Fail state	14.2.1.5	C		CS0 must not be sent

#### 14.10.4.5.7 Jabber function

	Parameter	Subclause	Req	Imp	Value/Comment
JF1	Jabber Function implementation	14.2.1.6	M		Self-interrupt of transmit and loopback
JF2	Xmit_max timer range	14.2.1.6	M		20 ms min, 150 ms max
JF3	CI circuit during jabber	14.2.1.6	M		CS0 signal
JF4	Unjab timer range	14.2.1.6	M		0.5 s $\pm$ 0.25 s
JF5	MAU Jabber Lockup Protection	14.2.1.6	M		Jabber not activated by the longest permitted output specified in 9.6.5



**14.10.4.5.8 Link Integrity Test function**

	Parameter	Subclause	Req	Imp	Value/Comment
LF1	Link_loss timer	14.2.1.7	M		50 ms min, 150 ms max
LF2 LF3 LF4	Signals during detected failure: TD circuit DI circuit CI circuit	14.2.1.7	M M M		TP_IDL IDL IDL (except when jabber condition is also present)
LF5	Link Test Fail state exit conditions	14.2.1.7	M		RD = active or consecutive link test pulses = 2 min, 10 max
LF6	Link_test_min timer range	14.2.1.7	M		2 to 7 ms
LF7	Link_test_max timer range	14.2.1.7	M		25 to 150 ms
LF8 LF9	Pulses outside acceptance window: Early while in Link Test Pass state Early or late while not in Link Test Pass state	14.2.1.7	M M		Ignore Reset link test pulse counter
LF10 LF11 LF12 LF13 LF14	Link fail effect on MAU functions: Transmit Receive Loopback Collision Presence SQE Test	14.2.1.7	M M M M M		Disable Disable Disable Disable Disable
LF15	Link Test Fail Extend state exit condition	14.2.1.7	M		Deferred until RD = idle and DO = idle
LF16	Power-on state	14.2.1.7	O		Link Test Fail Reset
LF17	Pulse/data discrimination	14.2.1.7	M		Link test pulse not detected as data

#### 14.10.4.5.9 MAU state diagram requirements

	Parameter	Subclause	Req	Imp	Value/Comment
SD1	Transmit, Receive, Loopback, and Collision Presence Functions state diagram	14.2.3	C		Meets requirements of Figure 14–3. Conditional on whether or not the function is to be performed (14.10.4.5.1/MF3 and 14.10.4.5.1/MF4).
SD2	MAU Transmit and Receive Functions state diagram (full duplex mode)	14.2.3	C		Conditional on whether or not the function is to be performed (14.10.4.5.1/MF3 and 14.10.4.5.1/MF4).
SD3	<i>signal quality error</i> Message Test Function state diagram	14.2.3	C		Meets requirements of Figure 14–4. Conditional on whether or not the function is to be performed (14.10.4.5.1/MF7).
SD4	Jabber Function state diagram	14.2.3	M		Meets requirements of Figure 14–5.
SD5	Link Integrity Test Function state diagram	14.2.3	M		Meets requirements of Figure 14–6.

#### 14.10.4.5.10 AUI requirements

	Parameter	Subclause	Req	Imp	Value/Comment
AR1	AUI implementation	14.3	O		If implemented, refer to 14.10.4.6.
AR2	AUI messages	14.2.2	M		Comply to 7.2.1.

#### 14.10.4.5.11 Isolation requirements

	Parameter	Subclause	Req	Imp	Value/Comment
IR1a	Isolation, MDI leads to DTE Physical Layer circuits	14.3.1.1	C		Any one of three tests listed in 14.3.1.1 Function provided by MAUs that do not encompass the PI of a PD within their MDI.
IR1b	Isolation, MDI leads to all external conductors	14.3.1.1	C		Any of the three tests listed in 14.3.1.1. Function provided by MAUs that encompass the PI of a PD within their MDI.
IR2	Resistance after breakdown test	14.3.1.1	M		≥ 2 MΩ at 500 Vdc

**14.10.4.5.12 Transmitter specification**

	Parameter	Subclause	Req	Imp	Value/Comment
TS1	Peak differential output voltage on TD circuit	14.3.1.2.1	M		2.2 to 2.8 V
TS2	Harmonic content, all-ones signal	14.3.1.2.1	M		All harmonics $\geq 27$ dB below fundamental
TS3	Output waveform, with scaling of voltage template	14.3.1.2.1	M		Within Figure 14–9 template
TS4	Start of TP_IDL waveform, with each specified load, with and without twisted-pair model	14.3.1.2.1	M		Within Figure 14–10 template, overshoot $\leq +50$ mV after excursion below $-50$ mV
TS5	Link test pulse waveform, with each specified load, with and without twisted-pair model	14.3.1.2.1	M		Within Figure 14–10 template, overshoot $\leq +50$ mV after excursion below $-50$ mV
TS6	TD circuit differential output impedance	14.3.1.2.2	M		Reflection $\geq 15$ dB below incident, any simplex link segment
TS7	Transmitter added timing jitter: Into $100 \Omega$ through twisted-pair model Into $100 \Omega$	14.3.1.2.3	M		$\pm 3.5$ ns max
TS8			M		$\pm 8$ ns max
TS9	Common-mode to differential-mode conversion	14.3.1.2.4	M		$\geq 29 - 17 \log_{10}(f/10)$ dB, $f=1-20$ MHz, $f$ in MHz
TS10	TD circuit common-mode output voltage	14.3.1.2.5	M		$< 50$ mV peak
TS11	TD circuit common-mode rejection, 15 V peak 10.1 MHz sinusoid	14.3.1.2.6	M		$\leq 100$ mV differential and $\leq 1$ ns jitter
TS12	TD circuit fault tolerance	14.3.1.2.7	M		No damage from a short circuit
TS13	TD circuit short-circuit current	14.3.1.2.7	M		300 mA max
TS14	TD circuit common-mode voltage withstand	14.3.1.2.7	M		1000 V min, applied per Figure 14–15
TS15	Power cycle behavior	14.3.2.3	M		No extraneous signals on the TD circuit

### 14.10.4.5.13 Receiver specification

	Parameter	Subclause	Req	Imp	Value/Comment
RS1	RD circuit signal acceptance	14.3.1.3.1	M		Figures 14–16, 14–17, template
RS2	Received signal jitter accept	14.3.1.3.1	M		At least $\pm 13.5$ ns
RS3	Receiver added jitter	14.3.1.3.1	M		$\leq \pm 1.5$ ns, RD to DI circuits
RS4	RD circuit link test pulse acceptance	14.3.1.3.2	M		Figure 14–12 template
RS5 RS6 RS7	RD circuit differential noise rejection: Signal (1) Signal (2) Signal (3)	14.3.1.3.2	M M M		$\leq 300$ mV peak $\leq 6.2$ V peak-to-peak, $\leq 2$ MHz Single cycle $\leq 6.2$ V, either phase, 2–15 MHz
RS8	Idle detection, RD circuit	14.3.1.3.3	M		Within 2.3 bit times
RS9	RD circuit differential input impedance	14.3.1.3.4	M		Reflected signal $\geq 15$ dB below incident, any simplex link segment
RS10	RD circuit common-mode rejection	14.3.1.3.5	M		25 V peak-to-peak square wave to add $\leq 2.5$ ns jitter
RS11 RS12	RD circuit fault tolerance: Short circuit Common-mode voltage	14.3.1.3.6	M M		Indefinite short circuit 1000 V impulse, applied per Figure 14–19

**14.10.4.5.14 MDI requirements**

	Parameter	Subclause	Req	Imp	Value/Comment
MR1	MDI connector	14.5.1	M		IEC 60603-7 jack
MR2 MR3 MR4 MR5	MDI connector contact assignment: 1 2 3 6	14.5.1	M M M M		TD+ TD- RD+ RD-
MR6	Crossover function implemented	14.5.2	O		Remote MAU from DTE (recommended)
MR7	Crossover function indication	14.5.2	C		X symbol on MDI connector. Conditional on crossover function implementation. Refer to response to 14.10.4.5.14/MR6
MR8 MR9 MR10 MR11	MDI-X connector contact assignment: 1 2 3 6	14.5.2	C C C C		RD+ RD- TD+ TD- Conditional on crossover function implementation. Refer to response to 14.10.4.5.14/MR6.

**14.10.4.5.15 Safety requirements**

	Parameter	Subclause	Req	Imp	Value/Comment
SR1	Safety grounding path	14.7.2.2	C		Must be via PG circuit. Conditional on AUI implementation. Refer to response for 14.10.4.5.10/AR1 or PIXIT
SR2	MAU labeling	14.8	O		Data rate, current, any applicable safety warnings (recommended)
SR3	General safety	14.7.1	M		Conforms to IEC 60950:1991
SR4	Application of telephony voltages	14.7.2.4	M		Creates no safety hazard

#### 14.10.4.6 PICS proforma tables for MAU AUI characteristics

The whole of 14.10.4.6 is conditional on the AUI being implemented and accessible for testing. Refer to response for Clause 14.10.4.5.10/AR1 or PIXIT.

##### 14.10.4.6.1 Signal characteristics

	Parameter	Subclause	Req	Imp	Value/Comment
SC1	Signaling rate (stated on label)	7.3.2	C		10 Mb/s
SC2	CS0 signal frequency (on CI)	7.3.1.2	C		10 MHz $\pm$ 15%
SC3	CS0 signal duty cycle	7.3.1.2	C		60:40 worst case

##### 14.10.4.6.2 DI and CI driver characteristics

	Parameter	Subclause	Req	Imp	Value/Comment
DC1 DC2 DC3	Differential output voltage: Loaded Idle state Start of idle	7.4.1.1	C C C		Figure 7-11 $\leq$ 40 mV into test load Figure 7-12
DC4	Current into test load while idle	7.4.1.1	C		4 mA max after 80 BT
DC5	Requirements after idle	7.4.1.2	C		First bit to Figure 7-11
DC6	Common-mode output voltage, ac	7.4.1.3	C		$\leq$ 40 mV peak. Figure 7-13
DC7	Differential output voltage, open circuit	7.4.1.4	C		13 V peak max
DC8	Common-mode output voltage, dc	7.4.1.5	C		$\leq$ 5.5 V. Figure 7-13
DC9	Fault tolerance	7.4.1.6	C		Figure 7-14
DC10	Fault current	7.4.1.6	C		$\leq$ 150 mA, any Figure 7-14 state

**14.10.4.6.3 DO receiver characteristics**

	Parameter	Subclause	Req	Imp	Value/Comment
DO1	Unsquelled threshold	7.4.2.1	C		160 mV max differential
DO2	Squelch	14.3.2.1	C		Reject signals $\leq$ 160 mV magnitude
DO3	High-to-idle transition on DO circuit	7.4.1.1	C		Must not cause output
DO4	Differential input impedance at 10 MHz	7.4.2.2	C		Real part: $77.83 \Omega \pm 6\%$ , $0 \leq$ phase angle in degrees $\leq$ real part $\times 0.0338$
DO5	Common-mode range, ac	7.4.2.3	C		3 V min 30 Hz to 40 kHz, 100 mV min 40 kHz to 10 MHz
DO6	Total common-mode range	7.4.2.4	C		Magnitude of 0 to 5.5 V ac + dc
DO7	Common-mode current limit	7.4.2.4	C		$\leq 1$ mA
DO8	IDL detection	7.3.1.1	C		$\leq 1.6$ bit times
DO9	Requirements after idle	7.4.2.5	C		Receiver in specification after start-up delay
DO10	Receiver fault tolerance	7.4.2.6	C		Figure 7–15
DO11	Input fault current	7.4.2.6	C		3 mA max for Figure 7–15

**14.10.4.6.4 Power consumption**

	Parameter	Subclause	Req	Imp	Value/Comment
PC1	Power surge limitation	14.3.2.3	C		$\leq 2 \times 10^{-3}$ A·s
PC2	Power surge duration	14.3.2.3	C		100 ms max
PC3	Steady-state current drawn	14.3.2.3	C		$\leq 500$ mA
PC4 PC5	Power-up capability: Current limited sources Voltage sources	14.3.2.3 7.5.2.5	C C		500 mA limited 11.28 to 15.75 V, any permissible AUI cable
PC6	Power cycle behavior	14.3.2.3	C		No extraneous signals on CI nor DI circuits
PC7	Low VP circuit behavior	7.5.2.5	C		No disruption of media

#### 14.10.4.6.5 Circuit termination

	Parameter	Subclause	Req	Imp	Value/Comment
CT1	Common-mode termination	7.5.2.6	C		If used must be to VC
CT2	Pins 1,4,11,14 impedance to VC circuit	7.5.2.8	C		$\leq 5 \Omega$ at 5 MHz
CT3	Pins 1,4,11,14 coupling to VC circuit	7.5.2.8	C		Capacitive

#### 14.10.4.6.6 Mechanical characteristics

	Parameter	Subclause	Req	Imp	Value/Comment
MC1	D-type connector dimensions	7.6.2	C		IEC 60807-2:1992 15-pole male
MC2	Shell plating material	7.6.2	C		Conductive
MC3	Shell multiple contact points	7.6.2	O		Number not defined (recommended)
MC4	Shell life expectancy	7.6.2	C		$\leq 5 \text{ m}\Omega / 500$ matings
MC5	Locking posts and mounting	7.6.1	C		Figures 7–17, 7–19
MC6	Pin connections:	7.6.3	C		Circuit
MC7			C		Data out A
MC8			C		Data out B
MC9			C		Capacitor to VC
MC10			C		Data in A
MC11			C		Data in B
MC12			C		Capacitor to VC
MC13			C		No connection
MC14			C		No connection
MC15			C		Capacitor to VC
MC16			C		Control in A
MC17			C		Control in B
MC18			C		Capacitor to VC
MC19			C		Voltage common
MC20			O		Voltage plus
MC21			C		Capacitor to VC
			C		Protective Ground (Conductive Shell)



**14.10.4.7 PICS proforma tables for 10BASE-T link segment****14.10.4.7.1 10BASE-T link segment characteristics**

	Parameter	Subclause	Req	Imp	Value/Comment
LS1	Cable size: 25-pair cable or binder groups	14.4.3.1.1	O		Cable size affects NEXT limits
LS2	4-pair cable	14.4.3.1.2	O		
LS3	Other	14.4.3.1.3	O		
LS4	Insertion loss, 5.0 to 10 MHz	14.4.2.1	M		$\leq 11.5$ dB
LS5	Differential characteristic impedance of a 3 m cable section, 5.0 to 10 MHz	14.4.2.2	M		85 to 111 $\Omega$
LS6	Input impedance averaged, 5.0 to 10 MHz	14.4.2.2	M		85 to 111 $\Omega$
LS7	Medium timing jitter (for defined test signal)	14.4.2.4	M		$\pm 5.0$ ns max
LS8	Delay: Per meter		M		$\leq 5.7$ ns/m
LS9	Link segment		M		$\leq 1000$ ns
LS10	NEXT loss, pair-to-pair, 5.0 to 10 MHz: 25-pair cable and binder groups	14.4.3.1.1	C		$\geq 30 - 15 \log_{10}(f/10)$ dB
LS11	4-pair cable	14.4.3.1.2	C		$\geq 26 - 15 \log_{10}(f/10)$ dB These requirements are conditional on the responses in clauses 14.10.4.7.1/LS1 and 14.10.4.7.1/LS2, $f$ in MHz
LS12	MDNEXT at 5.0, 7.5, and 10 MHz	14.4.3.2	M		$\geq 23 - 15 \log_{10}(f/10)$ dB, $f$ in MHz
LS13	Noise environment: Impulse noise (into defined circuit)	14.4.4.1	M		Fewer than 0.2 impulses/s of $\geq 264$ mV
LS14	Crosstalk noise	14.4.4.2	M		$\leq 264$ mV
LS15	Connectors	14.5.1	M		IEC 60603-7 plug
LS16	Literature indicates the distance and environmental conditions over which 14.4 specifications are met	14.7.3.2	O		

#### 14.10.4.8 PICS proforma tables for Auto-Negotiation able MAUs

The following are conditional on whether the Auto-Negotiation algorithm is provided (Clause 28).

	Parameter	Subclause	Req	Imp	Value/Comment
AN1	TP_IDL	14.2.1.1	C		Defined in 28.2.1
AN2	Link Integrity Test Function State Diagram power-on default	14.2.1.7	C		Power-on in Link Test Fail Reset state
AN3	Link Test Fail state exit conditions	14.2.1.7	C		autoneg_wait_timer expired and either RD = active or consecutive link test pulses = 3 min., 10 max
AN4	Technology Dependent Interface support	14.2.1.7	C		In the Link Integrity Test state diagram function “link_status=OK” is added to the LINK TEST PASS state and “link_status=FAIL” is added to the LINK TEST FAIL RESET state
AN5	Link test pulse waveform for FLP Burst with and without twisted-pair model	14.3.1.2.1	C		Within Figure 14–10 template for, all pulses in FLP Burst, overshoot $\leq +50$ mV after excursion below $-50$ mV
AN6	MAU indicates full duplex mode capability during Auto-Negotiation	14.2.1.8	C		Function optionally performed by embedded MAUs, not performed by MAUs that implement an AUI connector.

## 15. Fiber optic medium and common elements of medium attachment units and star, type 10BASE-F

### 15.1 Scope

#### 15.1.1 Overview

Clause 15, Clause 16, Clause 17, and Clause 18 define the functional, electrical, optical, and mechanical characteristics of the type 10BASE-FP (Passive) MAU, the type 10BASE-FB Backbone (Synchronous Active) MAU, the type 10BASE-FL Link (Asynchronous Active) MAU, the type 10BASE-FP (Passive) Star, and one common medium for use with those MAUs and the star. The purpose of the MAUs is to provide a means of attaching full duplex DTEs (10BASE-FL only), half duplex DTEs (10BASE-FP and 10BASE-FL only), or repeaters to the local network medium. The purpose of the 10BASE-FP Star is to provide the means of interconnecting 10BASE-FP MAUs into a star topology segment. The IEEE 802.3 repeaters are used to interconnect the star segment to other 10 Mb/s baseband segments. Information on selecting segment types for various applications is provided in 15.1.3.4.

The 10BASE-F specification builds upon Clause 1 through Clause 7 and Clause 9 of this standard. The relationship of this clause to the entire ISO/IEC 8802-3 LAN International Standard is shown in Figure 15–1a), Figure 15-1b), and Figure 15-1c) for 10BASE-FP, 10BASE-FB, and 10BASE-FL, respectively.

10BASE-F is specifically intended to be interoperable and compliant with the requirements for attachment to DTEs and repeaters via the 10 Mb/s Attachment Unit Interface (AUI). The use of 10BASE-F in networks with other IEEE 802.3, 10 Mb/s baseband segments is governed by the system considerations detailed in Clause 13.

##### 15.1.1.1 Fiber optic medium attachment units (MAUs)

The MAUs specified in this clause, Clause 16 (10BASE-FP), Clause 17 (10BASE-FB), and Clause 18 (10BASE-FL) have the following general characteristics:

- a) They provide a means of coupling the PLS through the AUI to the fiber optic segment by way of the MDI.
- b) They support message traffic at a data rate of 10 Mb/s.
- c) They provide for driving up to 1 km of fiber optic cable with a 10BASE-FP Star connected in the middle between two 10BASE-FP MAUs. Provide for driving up to 2 km of fiber optic cable between two repeaters that have embedded 10BASE-FB MAUs. Provide for driving up to 2 km of fiber optic cable between two 10BASE-FL MAUs. Provide backward compatibility for communicating between FOIRL MAUs and 10BASE-FL MAUs over up to 1 km of fiber optic cable.
- d) They permit the DTE to test the MAU and the availability of the medium.
- e) They support system configurations using the CSMA/CD access mechanism defined in this standard.
- f) They provide uninterrupted carrier sense during collisions.
- g) They support a star cabling topology.
- h) They allow incorporation of the MAU within the physical bounds of a DTE or repeater. (See Clause 17 for 10BASE-FB restrictions.)

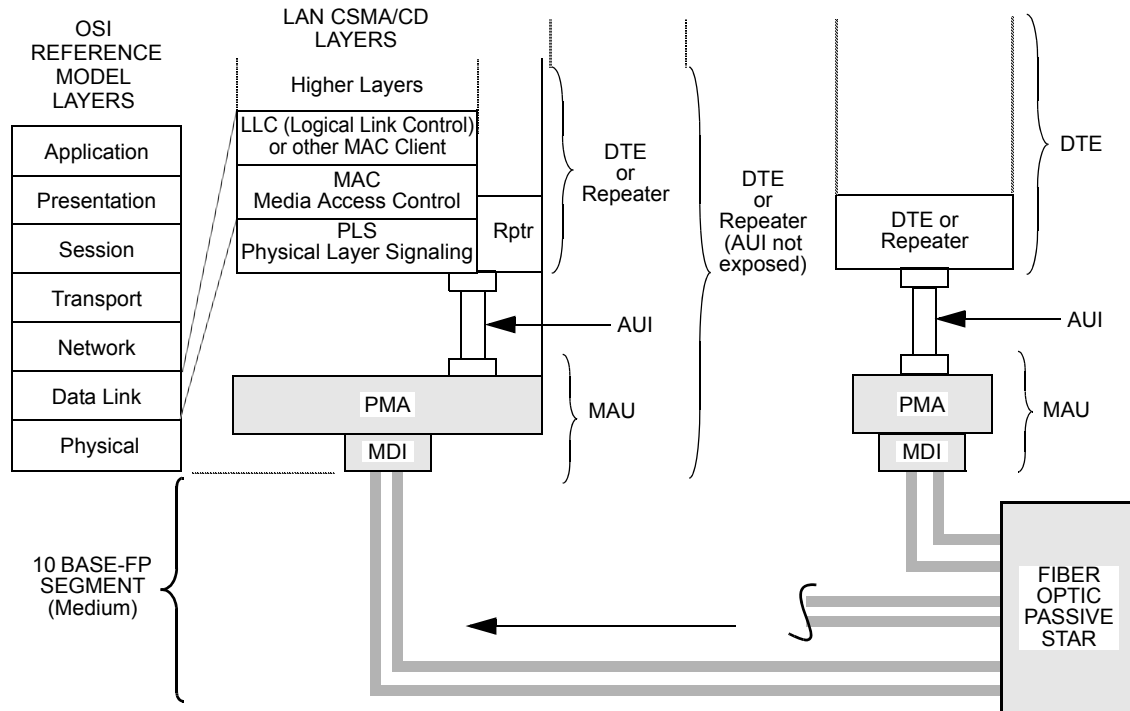
##### 15.1.1.2 Fiber optic passive star

The 10BASE-FP Star is a passive optical device that receives optical signals from, and distributes them to, connected devices (see Figure 15–2b). The 10BASE-FP Star is not a repeater.

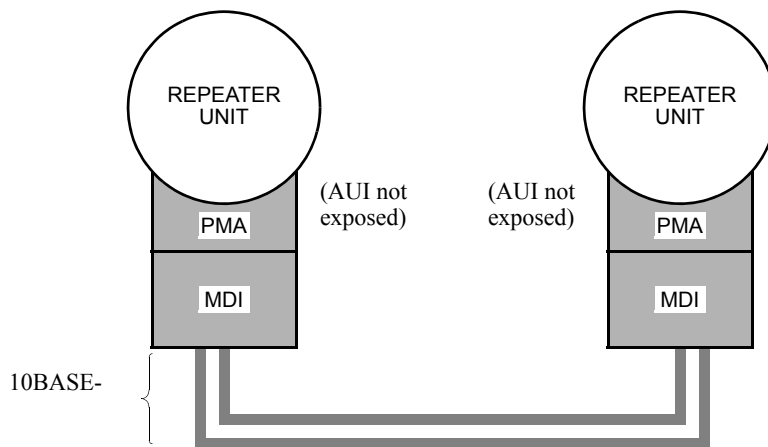
### 15.1.1.3 Repeater unit

The repeater unit has the characteristics defined in Clause 9. Repeater units are used as a hub in a star topology network in which DTEs attach directly to link segments. Repeater units are also used to extend the physical system topology of mixing segments by connecting 10BASE-FP or coaxial cable segments to other segments. Repeater units are used to connect 10BASE-F segments of any type to other 10BASE-F segments, and to any other 10 Mb/s baseband media types. 10BASE-FB segments connect only 10BASE-FB ports on repeaters.

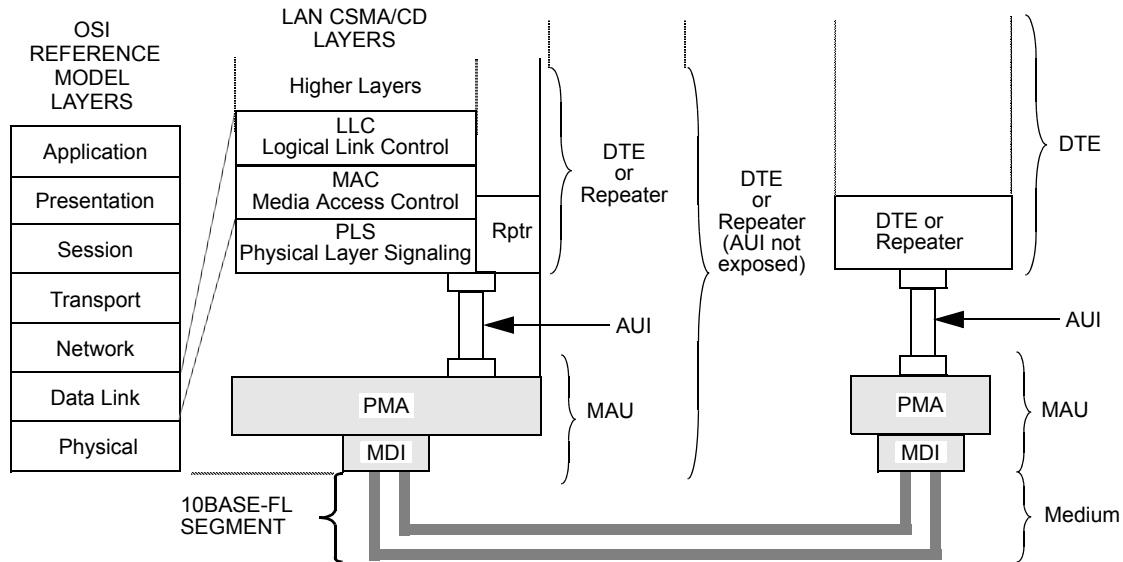
NOTE—While 9.6.6 autopartitioning is not required as a mandatory feature on 10BASE-FB ports, it should be recognized that it could be of benefit where there is a high probability of misconnections of incompatible ports, e.g., patch panels shared between 10BASE-FB and other fiber optic communication technologies.



**Figure 15-1—10BASE-F relationship to the ISO/IEC Open Systems Interconnection (OSI) reference model and the IEEE 802.3 CSMA/CD LAN model**



**b) 10BASE-FB relationship to CSMA/CD LAN**



c) 10BASE-FL relationship to OSI and CSMA/CD LAN

**Figure 15-1—(Continued)**  
**10BASE-FL relationship to the ISO/IEC Open Systems Interconnection (OSI)**  
**reference model and the ISO/IEC CSMA/CD LAN model**

### 15.1.2 Definitions

See 1.4.

### 15.1.3 Applications perspective: MAUs, stars, and fiber optic medium

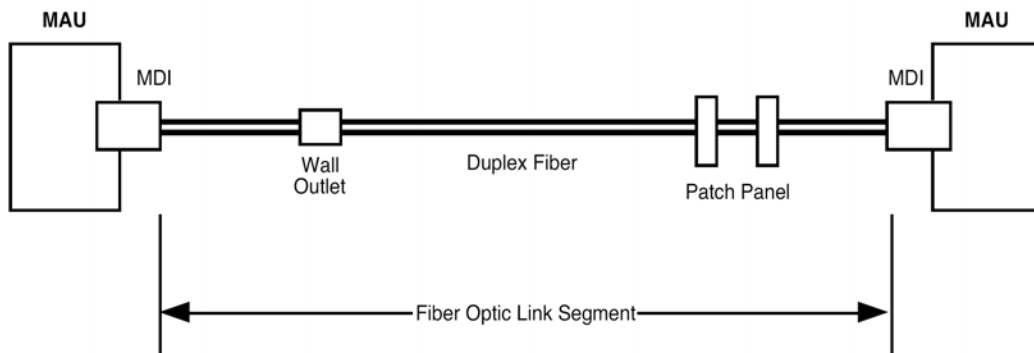
This clause states the broad objectives and assumptions underlying the specifications defined in Clause 15, Clause 16, Clause 17, and Clause 18.

#### 15.1.3.1 Objectives

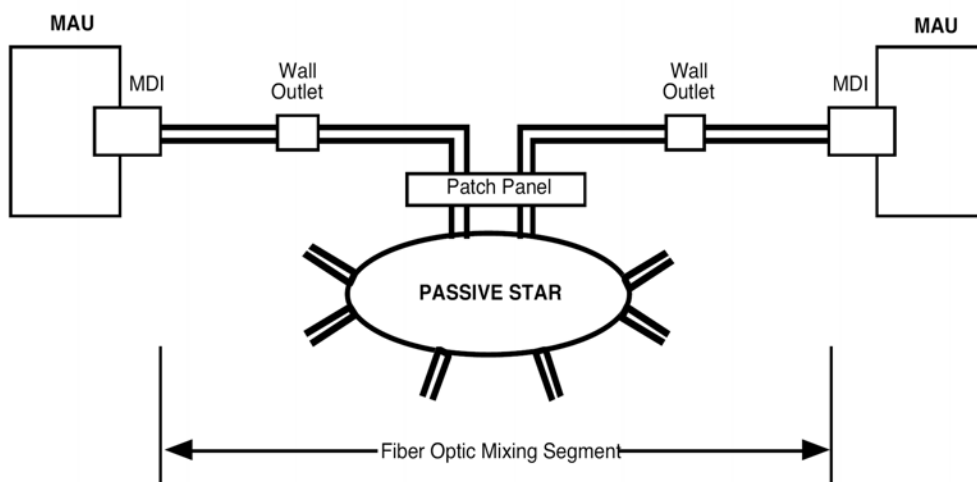
- To provide a physical means for communication between LAN data link entities using fiber optic media connected in a star topology.
- To ensure compatibility of independently developed physical, electrical, and optical interfaces.
- To provide a communication channel capable of high bandwidth and low bit-error ratio performance. The resultant mean bit-error ratio, between AUIs over a fiber segment, should be less than one part in  $10^9$ .
- To provide for ease of installation and service.
- To ensure that fairness of DTE access is not compromised.

#### 15.1.3.2 Compatibility considerations

All implementations of 10BASE-FP, 10BASE-FB, and 10BASE-FL fiber optic systems shall be compatible at their respective MDIs when used in accordance with the restrictions of Clause 9 and 16.5 where appropriate. When FOIRL segments are used, all 10BASE-FL MAUs shall be compatible with the FOIRL MDI specified in 9.9 except for the media connector, which shall be as specified in 15.3.2.



a) Example fiber optic link segment, 10BASE-FB and 10BASE-FL



b) Example fiber optic mixing segment, 10BASE-FP

**Figure 15–2—Fiber optic link and mixing segments**

Implementations of 10BASE-F of any one type are not compatible with 10BASE-F of any other type at the MDI.

Clause 15 provides medium specifications for interconnection of the fiber optic MAUs and star defined in Clause 16, Clause 17, and Clause 18. The star specified in 16.5 completes the specification of the media for a 10BASE-FP segment. The medium itself, the functional capability of the 10BASE-FP, 10BASE-FB, and 10BASE-FL MAUs, and the AUI are defined to provide the highest possible level of compatibility among devices designed by different manufacturers. Designers are free to implement circuitry within the MAU in an application-dependent manner provided that the MDI and AUI specifications are satisfied. The provision of the physical and mechanical implementation of the AUI is optional for Clause 16 and Clause 18 MAUs, and is not applicable for Clause 17 MAUs.

### 15.1.3.3 Relationship to PLS and AUI

Clause 15, together with Clause 16, Clause 17, or Clause 18, defines the portion of the Physical Layer and medium for the LAN necessary to couple a DTE or repeater message path to and from the medium.

A close relationship exists between Clause 7 and the 10BASE-FP, 10BASE-FB, and 10BASE-FL MAUs defined in Clause 16, Clause 17, and Clause 18, respectively. Clause 15 specifies the physical medium parameters, and Clause 16, Clause 17, and Clause 18 the PMA logical functions residing in the physical MAU. The MAU provides services to the PLS defined in Clause 7 by means of the AUI. 10BASE-F MAUs support a subset of the AUI services specified in Clause 7. 10BASE-F MAUs do not support the optional *isolate* function, the optional CO circuit, or the optional CS1 signal on the CI circuit.

The design of an external MAU component requires the use of Clause 15, Clause 16 or Clause 18, and Clause 7 for the PLS and AUI specifications.

The figures and numerous textual references throughout Clause 15, Clause 16, Clause 17, and Clause 18 refer to terminology associated with the AUI (that is, DO, DI, and CI). Since an embodiment of the 10BASE-FP, 10BASE-FB, or 10BASE-FL MAU does not require implementation of an AUI, the DO, DI, and CI circuits may not physically exist. However, they are logically present, and MAU operation is defined in terms of their messages.

#### 15.1.3.4 Guidelines for implementation of systems

The fiber optic systems defined herein cover a wide range of LAN applications in which the advantages of fiber optics are paramount. These advantages include noise immunity, low attenuation, bandwidth upgradeability, data security, and use in environments where the use of electric circuits would be hazardous. These systems allow construction of complex networks according to the system topology rules in Clause 13. Choice of system approach may be aided by the following guidelines:

- 10BASE-FP, Clause 16: A passive-star system for interconnecting repeaters or DTEs with up to 1 km per segment, useful where central power is unavailable or not sufficiently reliable for the intended application.
- 10BASE-FB, Clause 17: A system for interconnecting repeaters with up to 2 km per segment and for backbone applications where a large number of repeaters must be cascaded.
- 10BASE-FL, Clause 18: A system for interconnecting repeaters or DTEs with up to 2 km per segment and where backward compatibility with 9.9 (FOIRL) (up to 1 km per segment) is desirable. This system also supports full duplex operation (see 1.1.2).

Repeaters (Clause 9) must be used to connect other media to the above fiber optic segments. Repeaters also must be used to interconnect FOIRL, 10BASE-FB, 10BASE-FP, and 10BASE-FL segments. 10BASE-FB segments can be used only between 10BASE-FB ports on repeaters.

#### 15.1.3.5 Modes of operation

10BASE-F MAUs are capable of operating in normal mode only (see 7.1.4). They shall not operate in monitor mode. A MAU attached to a repeater shall not be in full duplex mode.

The operation of a 10BASE-FL MAU differs depending on whether the attached DTE is operating in the half duplex or full duplex mode (see 1.1.2). In the full duplex mode, functions relating to the loopback of transmitted data (DO) onto the receive path (DI) are disabled (see 18.3.1.3, 18.3.1.6).

The requirements specified in clauses of this standard labeled “half duplex mode only” do not apply to a MAU used with a DTE configured for full duplex operation. It is the responsibility of the designer and/or user of equipment operating in full duplex mode to ensure that the 10BASE-FL MAU used or incorporated is properly configured for full duplex operation.

10BASE-FP and 10BASE-FB MAUs are capable of operating in half duplex mode only.

## **15.2 MDI optical characteristics**

The transmit and receive optical parameters for the 10BASE-FP, 10BASE-FB, and 10BASE-FL fiber optic systems are summarized in Table 15–1. Optical measurements shall be made with the MDI terminated with the optical connector specified in 15.3.2 and the optical fiber specified in 15.3.1. Fiber length shall be sufficient to attenuate cladding mode distribution.

NOTE—Transmit and receive optical parameters refer to optical power in the core of the respective fiber (15.3.1). Fibers currently available typically require 1 m to 5 m to remove optical power from the cladding.

### **15.2.1 Transmit optical parameters**

#### **15.2.1.1 Center wavelength**

The center wavelength of the optical source emission shall be as specified in Table 15–1.

#### **15.2.1.2 Spectral width**

The full width half maximum (FWHM) spectral width of the optical source shall be as specified in Table 15–1.

#### **15.2.1.3 Optical modulation extinction ratio**

The optical modulation method is on-off keying of the optical power source. The minimum extinction ratio shall be as specified in Table 15–1, measured at the normalization points (15.2.1.11).

#### **15.2.1.4 Optical Idle Signal amplitude**

The optical Idle Signal shall be as specified in Table 15–1.

#### **15.2.1.5 Optical transmit pulse logic polarity**

LO on the AUI DO circuit shall be represented at the MDI as LO and as the higher optical power level transmitted at the MDI. HI on the AUI DO circuit shall be represented at the MDI as HI and as the lower optical power level transmitted at the MDI (see 7.4.2.1). A 10BASE-FP Star by its nature is noninverting from any input to any output.

#### **15.2.1.6 Optical transmit pulse rise and fall times**

The optical rise and fall times at the MDI transmitter shall be measured from the 10% to 90% levels. The rise and fall times and their difference shall be as specified in Table 15–1.

#### **15.2.1.7 Optical transmit pulse overshoot and undershoot**

The maximum optical overshoot and undershoot shall be as specified in Table 15–1.

#### **15.2.1.8 Optical transmit pulse edge jitter**

The total transmitted edge jitter measured at the MDI shall be as specified in Table 15–1 for a transmitted waveform consisting of a Manchester-encoded pseudo-random sequence with a minimum repetition period of 511 bits. The jitter at the MDI shall be measured at the power level median of the optical waveform's upper and lower power levels (as determined from the previous 16 or more transitions in any valid optical bit stream). This does not include any effects from variations of Optical Transmit Pulse Duty Cycle (15.2.1.9).



**Table 15–1—MDI parameters**

Subclause	Parameter	Units	10BASE-FP	10BASE-FB	10BASE-FL
15.2.1	TRANSMIT OPTICAL PARAMETERS				
15.2.1.1	Center wavelength —min. —max.	nm nm	800 910	800 910	800 910
15.2.1.2	Spectral width (FWHM)	nm	<75	<75	<75
15.2.1.3	Optical modulation extinction ratio	dB	≤13	≤13	≤13
15.2.1.4	Optical idle signal amplitude	dBm	≤57	see 15.2.1.10	see 15.2.1.10
15.2.1.6	Optical transmit pulse rise and fall times —max. (data) —min. (data) —max. difference (data) —max. (idle) —min. (idle) —max. difference (idle)	ns ns ns ns ns ns	10 2 3 N/A N/A N/A	10 0 3 10 0 3	10 0 3 25 0 25
15.2.1.7	Optical transmit pulse —overshoot —undershoot	% %	5 5	25 10	25 10
15.2.1.8	Optical transmit pulse edge jitter —added, DO circuit to MDI —total at MDI (data) —total at MDI (idle)	ns ns ns	N/A ±1 N/A	N/A ±2 ±2	±2 ±4 N/A
15.2.1.9	Optical transmit pulse Duty cycle distortion —data —idle	ns ns	±1 N/A	±2.5 ±2.5	±2.5 ±50.0
15.2.1.10	Optical transmit average power range —min. —max.	dBm dBm	–15 –11	–20 –12	–20 –12
15.2.2	RECEIVE OPTICAL PARAMETERS				
15.2.2.1	Optical receive average power range —min. —max.	dBm dBm	–41 –27	–32.5 –12.0	–32.5 –12.0
15.2.2.2	MAU optical receive edge jitter (data) —received at MDI —added, MDI to DI circuit —total at DI circuit (MAU end of AUI)	ns ns ns	±4.5 N/A N/A	±2.0 N/A ±6.5	±6.5 ±8.5 ±15.0
15.2.2.4	Optical receive pulse rise and fall times —max. (data) —min. (data) —max. difference (data) —max. (idle) —min. (idle) —max. difference (idle)	ns ns ns ns ns ns	18.5 2.0 3.0 N/A N/A N/A	31.5 0.0 3.0 31.5 0.0 3.0	31.5 0.0 3.0 41.0 0.0 25.0

### 15.2.1.9 Optical transmit pulse duty cycle distortion

The optical pulse duty cycle shall be as specified in Table 15–1. The duty cycle distortion measured at the output of the electro-optic source shall be measured at the power level median of the optical waveform’s upper and lower power levels (as determined in 15.2.1.10).

### 15.2.1.10 Optical transmit average power range

The optical transmit average power coupled into the core of the fiber shall be in the range specified in Table 15–1 at the MDI.

To meet the 10BASE-FP power range, the use of one or more techniques such as emitters with a focused radiation pattern, optical power setting, or temperature compensation may be necessary.

NOTE—The optical power ranges shown in Table 15–1 can be met by the following:

- 10BASE-FB and 10BASE-FL MDI
  - Nominal average power, beginning of life–15 dBm
  - Transmit power tolerance\* $\pm$ 3 dB
  - Transmit power degradation, end of life–2 dB
- 10BASE-FP MDI
  - Nominal average power, beginning of life–12.5 dBm
  - Transmit power tolerance\* $\pm$ 1.5 dB
  - Transmit power degradation, end of life–1 dB

\* Transmit power tolerance includes emitter, optical connector, and optical fiber tolerances.

### 15.2.1.11 Optical transmit signal templates

The transmitted optical waveforms for the 10BASE-FP MAU, 10BASE-FB MAU, and 10BASE-FL MAU shall fall within the templates shown in Figure 15–3, Figure 15–4, and Figure 15–5, respectively, when normalized. Normalization is achieved by linearly scaling and shifting the waveform amplitude and shifting the waveform timebase so that it intersects the two normalization points indicated by the black dots on the templates. These templates show a graphical representation of the transmit parameters described in 15.2.1.3, 15.2.1.6, 15.2.1.8, and 15.2.1.9. Table 15–1 lists the appropriate numerical values for these parameters. If any conflict exists between the templates and Table 15–1, the table shall take precedence.

The definition of “normalized optical power” is indicated on Figure 15–3, Figure 15–4, and Figure 15–5. The measured optical power is scaled and shifted so that the definition of “0” optical power and “1” optical power is determined by the average signal value at the points indicated by the black dots on the figures.

### 15.2.1.11.1 10BASE-FP optical transmit signal template

The points of inflection for the template of Figure 15–3 are defined by the coordinate pairs contained in Table 15–2.

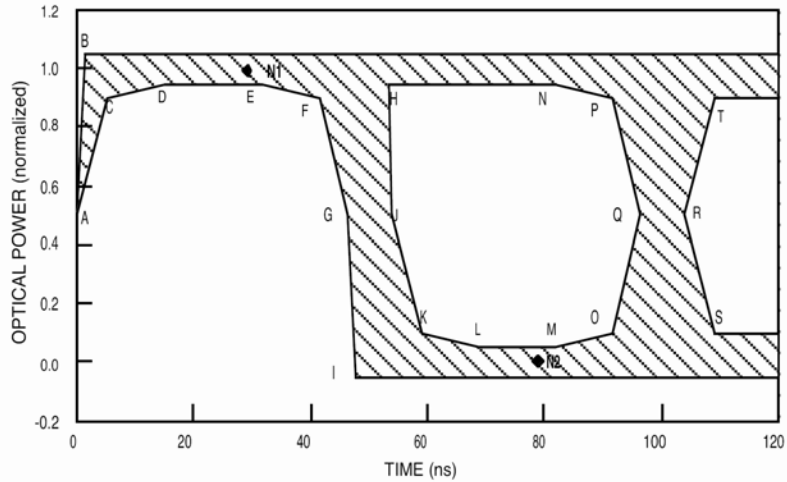


Figure 15–3—10BASE-FP MAU transmit waveform template

Table 15–2—Transmitted optical waveform values for Figure 15–3

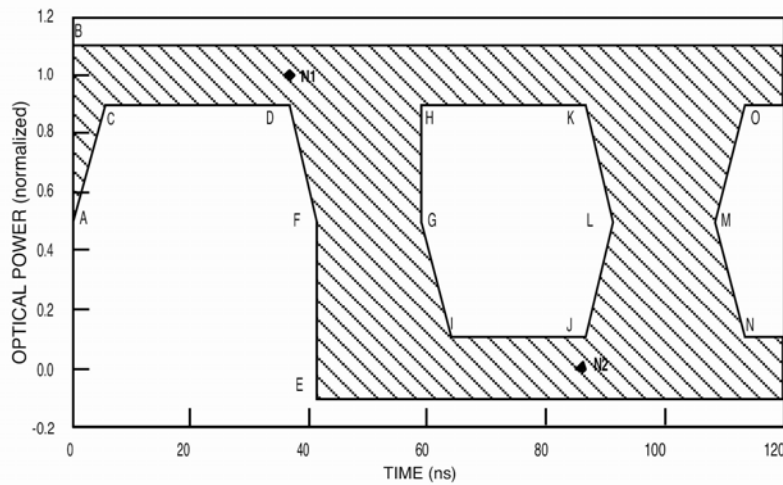
Reference	Time (ns)	Optical power (normalized)
A	0.0	0.5
B	1.375	1.05
C	5.0	0.9
D	15.0	0.95
E	31.0	0.95
F	41.0	0.9
G	46.0	0.5
H	52.875	0.95
I	47.375	–0.05
J	54.0	0.50
K	59.0	0.10
L	69.0	0.05

**Table 15–2—Transmitted optical waveform values for Figure 15–3 (continued)**

Reference	Time (ns)	Optical power (normalized)
M	81.0	0.05
N	81.0	0.95
O	91.0	0.10
P	91.0	0.90
Q	96.0	0.50
R	104.0	0.50
S	109.0	0.10
T	109.0	0.90
N1	29.0	1.00
N2	79.0	0.00

**15.2.1.11.2 10BASE-FB optical transmit signal template**

The points of inflection for the template of Figure 15–4 are defined by the coordinate pairs contained in Table 15–3.



**Figure 15–4—10BASE-FB MAU transmit waveform template**

**Table 15–3—Transmitted optical waveform for Figure 15–4**

Reference	Time (ns)	Optical power (normalized)
A	0.0	0.5
B	0.0	1.1
C	5.0	0.9
D	36.0	0.9
E	41.0	–0.1
F	41.0	0.5
G	59.0	0.5
H	59.0	0.9
I	64.0	0.1
J	86.0	0.1
K	86.0	0.9
L	91.0	0.5
M	109.0	0.5
N	114.0	0.1
O	114.0	0.9
N1	36.0	1.00
N2	86.0	0.00

### 15.2.1.11.3 10BASE-FL Optical transmit signal template

The points of inflection for the template of Figure 15–5 are defined by the coordinate pairs contained in Table 15–4. This template is for data only.

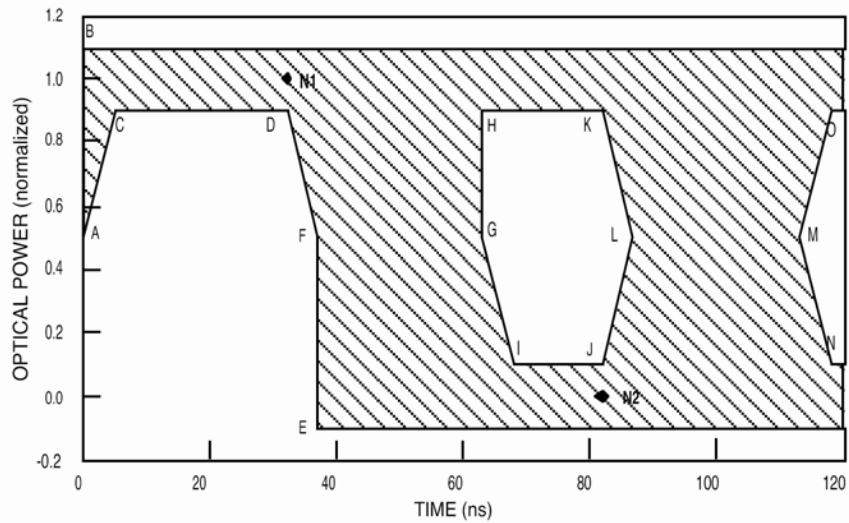


Figure 15–5—10BASE-FL MAU transmit waveform template (data only)

Table 15–4—Transmitted optical waveform values for Figure 15–5

Reference	Time (ns)	Optical power (normalized)
A	0.0	0.5
B	0.0	1.1
C	5.0	0.9
D	32.0	0.9
E	37.0	–0.1
F	37.0	0.5
G	63.0	0.5

**Table 15–4—Transmitted optical waveform values for Figure 15–5 (continued)**

Reference	Time (ns)	Optical power (normalized)
H	63.0	0.9
I	68.0	0.1
J	82.0	0.1
K	82.0	0.9
L	87.0	0.5
M	113.0	0.5
N	118.0	0.1
O	118.0	0.9
N1	32.0	1.00
N2	82.0	0.00

### 15.2.2 Receive optical parameters

The bit-error ratio (BER) shall be less than one part in  $10^9$ , when measured between two AUIs attached to a single 10BASE-FP, 10BASE-FB, or 10BASE-FL segment for all combinations of valid optical receive parameters specified in the following subclauses and valid optical transmit pulse duty cycle distortion (15.2.1.9). For the case of integrated MAUs this measurement must be made by inference.

#### 15.2.2.1 Optical receive average power range

The optical receive average power shall be in the range specified in Table 15–1 at the MDI when a single transmitter is transmitting on the medium.

#### 15.2.2.2 Optical receive pulse edge jitter

The received edge jitter shall be as specified for a received waveform consisting of a Manchester-encoded pseudo-random sequence with a minimum repetition period of 511 bits. The jitter at the input MDI shall be measured at the power level median of the optical waveform's upper and lower power levels (as determined from the previous 16 or more transitions in any valid bit stream). The jitter measured at the output of the DI circuit driver shall be measured at the zero crossing points (as determined from the previous 16 or more transitions in any valid bit stream).

NOTE—For the transmit optical parameters of Table 15–1 and the fiber parameters of 15.3.1, the contribution to jitter for a 2 km long fiber is less than 10 ps (.01 ns). For purposes of calculation and specifications, no jitter contribution is allocated to the fiber optic segment (including any 10BASE-FP Star).

Optical signals at the input of the MDI receiver shall be received and sent to the DI circuit if they have total received jitter of no more than that specified in Table 15–1.

The maximum additional edge jitter introduced at a MAU from the input of the MDI receiver to the output of the DI circuit driver shall be as specified in Table 15–1.

The total edge jitter at the output of the DI circuit driver shall be no more than that given by the sum of the worst-case edge jitter components specified in Table 15–1.

#### **15.2.2.3 Optical receive pulse logic polarity**

The higher optical power level received at the MDI shall be represented by LO at both the MDI and the AUI DI circuit. The lower optical power level received at the MDI shall be represented by HI at both the MDI and the AUI DI circuit (see 7.4.2.1).

#### **15.2.2.4 Optical receive pulse rise and fall times**

The optical rise and fall times at the MDI receiver shall be measured from the 10% to 90% levels. The rise and fall times and their maximum difference shall be as specified in Table 15–1 at the MDI.

### **15.3 Characteristics of the fiber optic medium**

The fiber optic transmission medium consists of one or more sections of fiber optic cables with any intermediate connectors required to connect sections together and terminated at each end in the optical connector plug as specified in 15.3.2. The fiber optic medium spans from one MDI to another MDI.

#### **15.3.1 Optical fiber and cable**

The optical medium requirements are satisfied by the 62.5/125  $\mu\text{m}$  nominal diameter fiber specified in IEC 60793-2:1992, type A1b with the exceptions noted in 15.3.1.1 to 15.3.1.3. For links under 5 m in length it may be necessary to use techniques such as attenuators or mode-stripping filters to attenuate optical power coupled into the cladding in order to meet the requirements of 15.2.2.1. The system can operate, subject to certain restrictions, with a variety of optical fibers. Information on other fiber sizes is contained in D.4. However, conformance to this standard and interoperability between different vendors' equipment is assured only through the use of the optical fiber specified in this subclause.

##### **15.3.1.1 Attenuation**

This standard was developed on the basis of an attenuation value of less than or equal to 3.75 dB/km, when measured at a wavelength of 850 nm. Higher loss fiber may be used for shorter fiber pair lengths as long as the requirements in 15.3.3 are met.

NOTE—This value of attenuation is a relaxation of the standard IEC 60793-2:1992, type A1b, category  $\leq 3.5$  dB/km and ISO/IEC 11801:2002.

##### **15.3.1.2 Modal bandwidth**

Each optical fiber shall have a modal bandwidth-length product of not less than 160 MHz·km at a wavelength of 850 nm.

NOTE—This value of modal bandwidth is a relaxation of the standard IEC 60793-2:1992, type A1b, category  $>200$  MHz·km and ISO/IEC 11801:2002.

##### **15.3.1.3 Propagation delay**

The propagation delay shall be  $\leq 5$   $\mu\text{s}/\text{km}$ . (This is equivalent to a velocity of propagation of 0.67c.)



**15.3.2 Optical medium connector plug and socket**

Each end of the fiber optic cable that is to be connected to a 10BASE-FP, 10BASE-FB, or 10BASE-FL MAU or a 10BASE-FP Star shall be terminated in the BFOC/2.5 connector plug shown in Figure 15–6 (for informational use only) (one per fiber), as specified in IEC 60874-10:1992. The corresponding mating connector sockets shown in Figure 15–7 (for informational use only) shall be used on all network elements covered by this specification (10BASE-FP MAU, 10BASE-FB MAU, 10BASE-FL MAU, and 10BASE-FP Star) to which the fiber optic cable attaches. In-line or patch panel connectors may be of other types, but must meet the requirements of 15.3.2.1 and 15.3.2.2.

NOTE—It is good practice to cap unused connectors to protect the system from ambient light and the connector interface from contamination.

**15.3.2.1 Optical connector insertion loss**

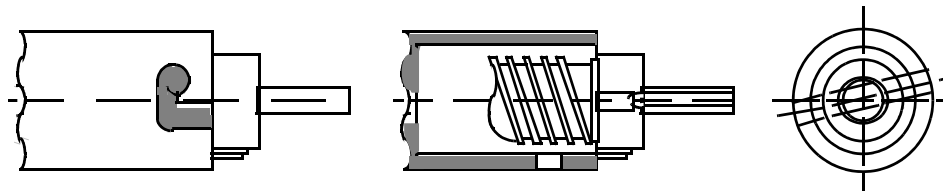
This standard was developed on the basis of a maximum insertion loss of 1.0 dB (see note below). Connectors with different loss characteristics may be used as long as the requirements in 15.3.2.2 and either 15.3.3.1 or 15.3.3.2 are met. Use of connectors with greater than 1.0 dB insertion loss is likely to reduce achievable transmission distances below those mentioned in 15.1.3.4.

NOTE—Per test method ANSI/EIA/TIA 455-34-1985 [B5], Method A, or ANSI/EIA/TIA 455-59-1989 [B8]. (No ISO/IEC test method was available at the time this standard was developed.)

**15.3.2.2 Optical connector return loss**

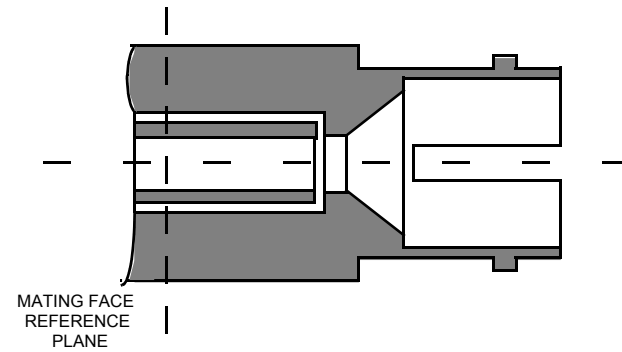
The return loss of optical connectors for 10BASE-FP segments shall be greater than 25 dB.

NOTE—The number of intermediate connectors in a fiber pair may have system implications because of return loss considerations (see B.5.2).



(informative only)

**Figure 15–6—BFOC/2.5 connector plug**



(informative only)

**Figure 15–7—BFOC/2.5 connector socket**

### 15.3.3 Fiber optic medium insertion loss

The optical insertion loss may be allocated between the elements of the fiber optic cable plant in any manner as long as the requirements of 15.3.3.1 and 15.3.3.2 are met. The optical insertion loss shall be measured in accordance with ANSI/EIA/TIA 526-14-1990 [B12], Method A, Two Reference Jumpers.

NOTE—No ISO/IEC test method was available at the time this standard was developed.

#### 15.3.3.1 10BASE-FP segment insertion loss

The optical insertion loss of the 10BASE-FP segment including 10BASE-FP Star shall be between 16 dB and 26 dB, measured using an optical signal source with a center wavelength of 850 nm and spectral width of 75 nm. The range of measured insertion losses across the 10BASE-FP segment shall be less than 6 dB for any given star output port with respect to all input ports (see note in 16.5.2.2). See B.5.2 for examples of system implementation.

#### 15.3.3.2 10BASE-FB and 10BASE-FL segment insertion loss

The optical insertion loss of the 10BASE-FB and 10BASE-FL segment shall be less than 12.5 dB, measured using an optical signal source with a center wavelength of 850 nm and spectral width of 75 nm.

### 15.3.4 Electrical isolation

Electrical isolation shall be provided between MDIs attached to the fiber optic cable. There shall be no conducting path between the optical medium connector plug and any conducting element within the fiber optic cable. This isolation shall withstand at least one of the following electrical strength tests:

- a) 1500 V rms at 50 Hz to 60 Hz for 60 s, applied as specified in 5.3.2 of IEC 60950:1991.
- b) 2250 Vdc for 60 s, applied as specified in 5.3.2 of IEC 60950:1991.
- c) A sequence of ten 2400 V impulses of alternating polarity, applied at intervals of not less than 1 s. The shape of the impulses shall be 1.2/50  $\mu$ s (1.2  $\mu$ s virtual front time, 50  $\mu$ s virtual time of half value) as defined in IEC 60060.

There shall be no isolation breakdown, as defined in 5.3.2 of IEC 60950:1991, during the test. The resistance after the test shall be at least 2 M $\Omega$  measured at 500 Vdc.

## 15.4 MAU reliability

The MAU shall be designed to have a Mean Time Before Failure (MTBF) of at least 10 million hours of continuous operation without causing communication failure among other stations attached to the network. Component failures within the MAU electronics should not prevent communication among other MAUs on the network.

## 15.5 MAU–AUI specification

When a MAU contains a physical AUI connector, the following specifications shall be met.

### 15.5.1 MAU–AUI electrical characteristics

The electrical characteristics for the driver and receiver components within the MAU that are connected to the AUI shall be identical to those specified in 7.4 and 7.5. Additionally, the AUI DO receiver shall reject an input waveform of less than  $\pm$  160 mV differential.

### 15.5.2 MAU–AUI mechanical connections

The MAU shall be provided with a 15-pin male connector as specified in 7.6.

### 15.5.3 Power consumption

Following power on, the surge current drawn by the MAU through the AUI shall be such that  $I_p \times T_w$  is less than or equal to  $2 \times 10^{-3}$  Ampere-seconds, where  $I_p$  is the peak surge current and  $T_w$  is the time during which the current exceeds the larger of 0.5 A or  $0.5 \times I_p$ . After 100 ms following power on, the current drawn by the MAU shall not exceed 0.5 A when powered by the AUI.

The MAU shall be capable of operating from all possible AUI voltage sources, including those current-limited to 0.5 A, as supplied by the DTE or repeater through the resistance of all permissible AUI cables.

It is permissible, as an option, to provide a separate power source for the MAU. If a separate power source is implemented, provision shall be made to assure that under no circumstances power can be sourced on pin 13 (Circuit VP) of the AUI. The separate power source if implemented shall withstand at least one of the tests of 15.3.4.

The MAU shall be labeled externally to identify the maximum value of power supply current required by the device when the AUI is implemented.

The MAU shall not introduce at the MDI or onto the DI or CI circuits of the AUI any extraneous signals on power-up or power-down.

### 15.5.4 MAU–AUI messages

The messages between the PLS in the DTE and the PMA in the MAU shall comply with 7.2.1. These messages also are used in repeater unit to PMA communications.

#### 15.5.4.1 PLS to PMA messages

The following messages are sent by the PLS in the DTE or repeater to the PMA in the MAU (see 7.2.1.1):

Message	Circuit*	Signal	Meaning
output	DO	CD1, CD0	Output information
output_idle	DO	IDL	No data to be output
* Or virtual equivalent for an embedded MAU.			

#### 15.5.4.2 PMA to PLS messages

The following messages are sent by the PMA in the MAU to the PLS in the DTE or repeater (see 7.2.1.2):

##### 15.5.4.2.1 *signal\_quality\_error* message

The *signal\_quality\_error* (SQE) message shall operate in the following fashion:

- a) The SQE message shall be sent whenever a collision exists, as described in 16.3.4, 17.3.3 or 18.3.1.4.

Message	Circuit*	Signal	Meaning
input	DI	CD1, CD0	Input information
input_idle	DI	IDL	No input information
signal_quality_error	CI	CS0	Collision or error detected by MAU
mau_available	CI	IDL	MAU is available for output
* Or virtual equivalent for an embedded MAU.			

- b) The SQE message shall be sent whenever a jabber condition exists, as described in 16.3.6 or 18.3.1.6.
- c) The SQE message shall be sent as a result of SQE Test, as described in 16.3.5 or 18.3.1.5. SQE Test shall not be performed by MAUs connected to repeaters.
- d) Under all other conditions, the MAU shall send the *mau\_available* message.

The MAU is required to assert the SQE message at the appropriate times, as described in a) through c) above, whenever the MAU is powered.

## 15.6 Environmental specifications

### 15.6.1 Safety requirements

An application of the equipment specified herein is for interconnecting equipment in different buildings. This may present hazards beyond the range of protection assured by 15.3.4. Installation practice shall be consistent with this application and provide adequate personnel and equipment safety from earth faults and lightning strike hazards.

Installation practice shall be in accordance with local and national regulations.

NOTE—While optical fibers are nonconducting, some fiber optic cables do contain metallic strength members or sheathing that must be considered during installation. However, since grounding of these metallic members does not involve the signal path, it is beyond the scope of this standard.

### 15.6.2 Electromagnetic environment

Sources of interference from the environment include electromagnetic fields, electrostatic discharge, and transient voltages between earth connections. The MAUs shall meet their specifications when operating in an ambient plane wave field of 2 V/m from 10 kHz through 30 MHz, and 5 V/m from 30 MHz through 1 GHz.

NOTE—These are levels typically found 1 km from radio broadcast stations.

The MAUs, stars, and associated connector/cable systems shall comply with applicable local and national codes, such as FCC Docket 20780-1980 [B30] in the USA. Equipment shall comply with local and national requirements for limitation of electromagnetic interference and susceptibility. Where no local or national requirements exist, equipment shall comply with CISPR 22: 1993.

### 15.6.3 Other environmental requirements

The MAUs, stars, and associated connector/cable systems are expected to operate over a reasonable range of environmental conditions related to temperature, humidity, and physical handling such as shock and vibration. Specific requirements and values for these parameters are considered to be beyond the scope of this standard. Manufacturers should indicate in the literature associated with a unit (and on the unit if possible) the operating environment specifications to facilitate selection, installation, and maintenance of these components. It is further recommended that such specifications be stated in standard terms, as specified in IEC 60068, IEC 60874-10:1992, IEC 60793-1:1992, and IEC 60794-1:1993.

### 15.7 MAU labeling

It is recommended that each MAU (and supporting documentation) be labeled in a manner visible to the user with at least these parameters:

- a) Whether 10BASE-FP MAU, 10BASE-FB MAU, or 10BASE-FL MAU
- b) Data rate capability in Mb/s
- c) Power level in terms of maximum current drain (for external MAUs as required by 15.5.3)
- d) Any applicable safety warnings
- e) Which connector is input and which is output
- f) For 10BASE-FP MAUs, the Manufacturer ID and the MAU ID in two separate fields (see 16.3.1.1.3)
- g) For 10BASE-FL MAUs, if capable of full duplex operation

#### 15.7.1 10BASE-FP star labeling

It is recommended that each 10BASE-FP Star (and supporting documentation) be labeled in a manner visible to the user with at least these parameters:

- a) Label as 10BASE-FP Star
- b) Label input/output connectors

## **15.8 Protocol implementation conformance statement (PICS) proforma for Clause 15, Fiber optic medium and common elements of medium attachment units and star, type 10BASE-F<sup>32</sup>**

### **15.8.1 Introduction**

The supplier of a protocol implementation that is claimed to conform to Clause 15, Fiber optic medium and common elements of medium attachment units and star, type 10BASE-F, shall complete the following PICS proforma.

A completed PICS proforma is the PICS for the implementation in question. The PICS is a statement of which capabilities and options of the protocol have been implemented. The PICS can be used for a variety of purposes by various parties, including the following:

- As a checklist by the protocol implementor, to reduce the risk of failure to conform to the standard through oversight;
- As a detailed indication of the capabilities of the implementation, stated relative to the common basis for understanding provided by the standard PICS proforma, by the supplier and acquirer, or potential acquirer, of the implementation;
- As a basis for initially checking the possibility of interworking with another implementation by the user, or potential user, of the implementation (note that, while interworking can never be guaranteed, failure to interwork can often be predicted from incompatible PICS);
- As the basis for selecting appropriate tests against which to assess the claim for conformance of the implementation, by a protocol tester.

### **15.8.2 Abbreviations and special symbols**

#### **15.8.2.1 Status symbols**

The following symbols are used in the PICS proforma:

- M is mandatory field/function
- O is optional field/function
- O.<n> is optional field/function, but at least one of the group of options labeled by the same numeral <n> is required
- O/<n> is optional field/function, but one and only one of the group of options labeled by the same numeral <n> is required
- X is prohibited field/function
- <item> is simple-predicate condition, dependent on the support marked for <item>

#### **15.8.2.2 Abbreviations**

- N/A Not applicable

### **15.8.3 Instructions for completing the pics proforma**

#### **15.8.3.1 General structure of the PICS proforma**

The first part of the PICS proforma, Implementation Identification and Protocol Summary, is to be completed as indicated with the information necessary to identify fully both the supplier and the implementation.

---

<sup>32</sup>*Copyright release for PICS proformas:* Users of this standard may freely reproduce the PICS proforma in this subclause so that it can be used for its intended purpose and may further publish the completed PICS.

The main part of the PICS proforma is a fixed-format questionnaire divided into subclauses, each containing a group of items. Answers to the questionnaire items are to be provided in the right-most column, either by simply marking an answer to indicate a restricted choice (usually Yes, No, or Not Applicable), or by entering a value or a set or range of values. (Note that there are some items where two or more choices from a set of possible answers can apply; all relevant choices are to be marked.)

Each item is identified by an item reference in the first column; the second column contains the question to be answered; the third column contains the reference or references to the material that specifies the item in the main body of the standard; the fourth column contains values and/or comments pertaining to the question to be answered. The remaining columns record the status of the item—whether the support is mandatory, optional, or conditional—and provide the space for the answers; see also 15.8.3.4.

The supplier may also provide, or be required to provide, further information, categorized as either Additional Information or Exception Information. When present, each kind of further information is to be provided in a further subclause of items labeled A<i> or X<i>, respectively, for cross-referencing purposes, where <i> is any unambiguous identification for the item (e.g., simply a numeral); there are no other restrictions on its format or presentation.

A completed PICS proforma, including any Additional Information and Exception Information, is the protocol implementation conformance statement for the implementation in question.

Note that where an implementation is capable of being configured in more than one way, according to the items listed under 15.8.5, Major Capabilities/Options, a single PICS may be able to describe all such configurations. However, the supplier has the choice of providing more than one PICS, each covering some subset of the implementation's configuration capabilities, if that would make presentation of the information easier and clearer.

### **15.8.3.2 Additional information**

Items of Additional Information allow a supplier to provide further information intended to assist the interpretation of the PICS. It is not intended or expected that a large quantity will be supplied, and the PICS can be considered complete without any such information. Examples might be an outline of the ways in which a (single) implementation can be set up to operate in a variety of environments and configurations; or a brief rationale, based perhaps upon specific application needs, for the exclusion of features which, although optional, are nonetheless commonly present in implementations of the 10BASE-F protocol.

References to items of Additional Information may be entered next to any answer in the questionnaire, and may be included in items of Exception Information.

### **15.8.3.3 Exception information**

It may occasionally happen that a supplier will wish to answer an item with mandatory or prohibited status (after any conditions have been applied) in a way that conflicts with the indicated requirement. No pre-printed answer will be found in the Support column for this; instead, the supplier is required to write into the Support column an X<i> reference to an item of Exception Information, and to provide the appropriate rationale in the Exception item itself.

An implementation for which an Exception item is required in this way does not conform to this standard.

Note that a possible reason for the situation described above is that a defect in the standard has been reported, a correction for which is expected to change the requirement not met by the implementation.

### 15.8.3.4 Conditional items

The PICS proforma contains a number of conditional items. These are items for which both the applicability of the item itself, and its status if it does apply—mandatory, optional, or prohibited—are dependent upon whether or not certain other items are supported.

Individual conditional items are indicated by a conditional symbol of the form “<item>:<s>” in the Status column, where “<item>” is an item reference that appears in the first column of the table for some other item, and “<s>” is a status symbol, M, O, or X.

If the item referred to by the conditional symbol is marked as supported, the conditional item is applicable, and its status is given by “<s>”; the support column is to be completed in the usual way. Otherwise, the conditional item is not relevant and the Not Applicable (N/A) answer is to be marked.

Each item whose reference is used in a conditional symbol is indicated by an asterisk in the Item column.

### 15.8.4 Identification

#### 15.8.4.1 Implementation identification

<b>Supplier</b>	
Contact point for queries about the PICS	
Implementation name(s) and version(s)	
Other information necessary for full identification—e.g., name(s) and version(s) for machines and/or operating systems; System Name(s)	
NOTE 1—Only the first three items are required for all implementations; other information may be completed as appropriate in meeting the requirements for the identification. NOTE 2—The terms Name and Version should be interpreted appropriately to correspond with a supplier’s terminology (e.g., Type, Series, Model).	

#### 15.8.4.2 Protocol summary

Identification of protocol specification	IEEE Std 802.3-2008, Clause 15, 10 Mb/s Fiber Optic Medium Attachment Unit (MAU) and Medium Specification, type 10BASE-F
Identification of amendments and corrigenda to this PICS proforma which have been completed as part of this PICS	
Have any Exception items been required? No [ ] Yes [ ] (See 15.8.3.3; The answer Yes means that the implementation does not conform to IEEE Std 802.3-2008.)	

Date of statement	
-------------------	--



**15.8.5 Major capabilities/options**

Item	Feature	Reference	Value/Comment	Status	Support
*FP	10BASE-FP Implementation	15.1.1	N/A	0.1	Yes [ ] No [ ]
*FB	10BASE-FB Implementation	15.1.1	N/A	0.1	Yes [ ] No [ ]
*FL	10BASE-FL Implementation	15.1.1	N/A	0.1	Yes [ ] No [ ]

In addition, the following predicate name is defined for use when different implementations from the set above have common parameters:

\*FA: FB or FL

**15.8.6 PICS Proforma for the fiber optic medium****15.8.6.1 Characteristics of the fiber optic medium**

Item	Feature	Reference	Value/Comment	Status	Support
*M1	Fiber size	15.3.1	62.5/125 $\mu\text{m}$	O	Yes [ ] No [ ]
M2	Attenuation of fiber	15.3.1.1	$\leq 3.75$ dB/km at 850 nm when 62.5/125 $\mu\text{m}$ fiber is used	M1: M	N/A [ ] M: Yes [ ]
M3	Fiber modal bandwidth	15.3.1.2	$\geq 160$ MHz·km at 850 nm	M	Yes [ ]
M4	Velocity of propagation	15.3.1.3	$\leq 5$ $\mu\text{s}/\text{km}$	M	Yes [ ]

### 15.8.6.2 Optical medium connector plug and socket

Item	Feature	Subclause	Value/Comment	Status	Support
MC1	Connector plug for termination of fiber	15.3.2	BFOC/2.5—see IEC 60874-10:1992	M	Yes [ ]
MC2	Optical connector loss	15.3.2.1	< 1.0 dB	O	Yes [ ]No [ ]
MC3	Optical connector return loss (10BASE-FP only)	15.3.2.2	> 25 dB	FP: M	N/A [ ]M: Yes [ ]

### 15.8.6.3 Fiber optic medium insertion loss

Item	Feature	Subclause	Value/Comment	Status	Support
	Fiber optic medium insertion loss		Measured as per ANSI/EIA/TIA 526-14-1990 [B12], Method A, using optical signal with center wavelength of 850 nm and spectral width of 75 nm		
IL1	10BASE-FP segment insertion loss (including 10BASE-FP Star)	15.3.3.1	Between 16 dB and 26 dB	FP: M	N/A [ ] M: Yes [ ]
IL2	10BASE-FB and 10BASE-FL segment insertion loss	15.3.3.2	< 12.5 dB	FA: M	N/A [ ] M: Yes [ ]
IL3	Range of insertion losses measured across one 10BASE-FP segment or one star output port	15.3.3.1	< 6 dB	FP: M	N/A [ ] M: Yes [ ]

### 15.8.6.4 Electrical isolation requirements

Item	Feature	Subclause	Value/Comment	Status	Support
IR1	Electrical isolation, optical connector plug to any electrically conducting element in cable	15.3.4	Any one of three tests listed in 15.3.4	M	Yes [ ]
IR2	Resistance after breakdown test	15.3.4	> 2 M $\Omega$ measured at 500 Vdc	M	Yes [ ]

## 16. Fiber optic passive star and medium attachment unit, type 10BASE-FP

NOTE—This MAU is not recommended for new installations. Since September 2003, maintenance changes are no longer being considered for this clause.

### 16.1 Scope

#### 16.1.1 Overview

This clause, along with Clause 15, defines the functional, electrical, optical, and mechanical characteristics of a fiber optic passive-star system for interconnecting DTEs and repeaters. The relationship of this clause to the entire ISO/IEC 8802-3 International Standard is shown in Figure 15–1a). This system, which may be interconnected to other 10 Mb/s baseband segments using repeaters, consists of the 10BASE-FP MAU (including a fiber optic MDI specified in 15.2), a 10BASE-FP fiber optic Star, and the fiber optic medium specified in 15.3. The 10BASE-FP MAU provides the means for attaching DTEs and repeaters to a 10BASE-FP Star LAN, and a 10BASE-FP Star provides the only means to interconnect 10BASE-FP MAUs via their MDIs.

##### 16.1.1.1 10BASE-FP medium attachment unit

The 10BASE-FP MAU has the following general characteristics:

- a) It supports a totally passive-star topology interconnection means.
- b) It connects a DTE or repeater to a 10BASE-FP fiber optic segment.
- c) It supports message traffic at a data rate of 10 Mb/s.
- d) It permits up to 500 m of fiber optic cable, as specified in 15.3, between 10BASE-FP MAUs and a 10BASE-FP Star. (See B.5.2.)
- e) It permits the DTE or repeater to confirm operation of the MAU and availability of the medium.
- f) It permits the DTE to test the collision detection circuitry of the MAU.
- g) It recodes the preamble prior to transmission at the MDI to allow passive-system collision detection and restores normal preamble to packets received at the MDI.
- h) It transmits coded jam during collision for deterministic detection of end of collision.
- i) It supports network configurations using the CSMA/CD access mechanism defined in this standard.

##### 16.1.1.2 10BASE-FP Star

The star has the following general characteristics:

- a) It supports a totally passive-star topology interconnection means.
- b) It receives an optical signal from any 10BASE-FP MAU connected to the passive fiber optic segment and distributes the signal uniformly to all 10BASE-FP MAUs connected to the passive fiber optic segment, including the one from which the transmission originated.
- c) It supports message traffic at a data rate of 10 Mb/s.
- d) It permits segments of up to 500 m radius of fiber optic cable, as specified in 15.3, among MAUs and the star. (See B.5.2.)
- e) It supports system configurations using the CSMA/CD access mechanism defined in this standard.

##### 16.1.1.3 Repeater unit

The repeater unit (Clause 9), along with 10BASE-FP MAUs (making a repeater set), is used to interconnect 10BASE-FP segments to achieve the maximum 10BASE-FP connection path. The repeater is also used to extend the physical system topology by connecting 10BASE-FP segments to 10BASE-FB and 10BASE-FL segments as well as all other 10 Mb/s baseband media types.

Multiple repeater units are permitted within a single collision domain to provide the maximum connection path length specified in Clause 13. The repeater is not a DTE and therefore has slightly different requirements for its attached MAUs as defined in 9.4.1. It is recommended that repeater sets with 10BASE-FP MAUs provide the auto partition/reconnection algorithm on those ports as specified in 9.6.6.2.

## 16.2 PMA interface messages

The messages between PLS in the DTE or the repeater and the PMA in the MAU shall comply with the PMA interface messages in 7.2.1 and 15.5.4. The messages between the PMAs over the MDI are summarized below.

### 16.2.1 PMA-to-MDI interface signal encodings

The following signals are used by the interface messages between the PMA and the MDI.

**Code Rule Violation, CRV.** See 15.1.2.

**Manchester-Coded Data One, CD1.** A clocked bit symbol in which the first half is LO and the second half is HI.

**Manchester-Coded Data Zero, CD0.** A clocked bit symbol in which the first half is HI and the second half is LO.

**Manchester Code Violation Zero, MV0.** A clocked bit symbol in which the symbol is LO for the bit duration.

**Received Idle, RDARK.** See 15.2.1.4 and 16.2.3.2.

**Transmitted Idle, TDARK.** See 15.2.1.4 and 16.2.2.2.

### 16.2.2 PMA-to-MDI OTD messages

The following messages can be sent by the MAU PMA to the MDI OTD (Optical Transmit Data) circuit:

Message	Circuit	Signal	Meaning
<i>OTD_output</i>	OTD	CD1, CD0	Output information
<i>OTD_idle</i>	OTD	TDARK	No data to be output
<i>OTD_manch_violation</i>	OTD	MV0	Manchester violation to be output

#### 16.2.2.1 OTD\_output

The PMA sublayer shall send the *OTD\_output* message to the OTD circuit when the DTE or repeater outputs a bit of data, as modified by the Preamble Encoding function (see 16.3.1.1 and Figure 16–1), and neither link fault nor jabber has been detected. The physical realization of the *OTD\_output* message shall be a CD0 or CD1 signal sent by the PMA.

#### 16.2.2.2 OTD\_idle

The PMA sublayer shall send the *OTD\_idle* message to the OTD circuit when the DTE or repeater sends idle or if either link fault or jabber has been detected. The physical realization of the *OTD\_idle* message shall be a TDARK signal sent by the PMA. TDARK shall be a signal with an optical level as specified in 15.2.1.4, Optical Idle Signal Amplitude, and shall have a duration of 1.5 bit times (BT) or greater.

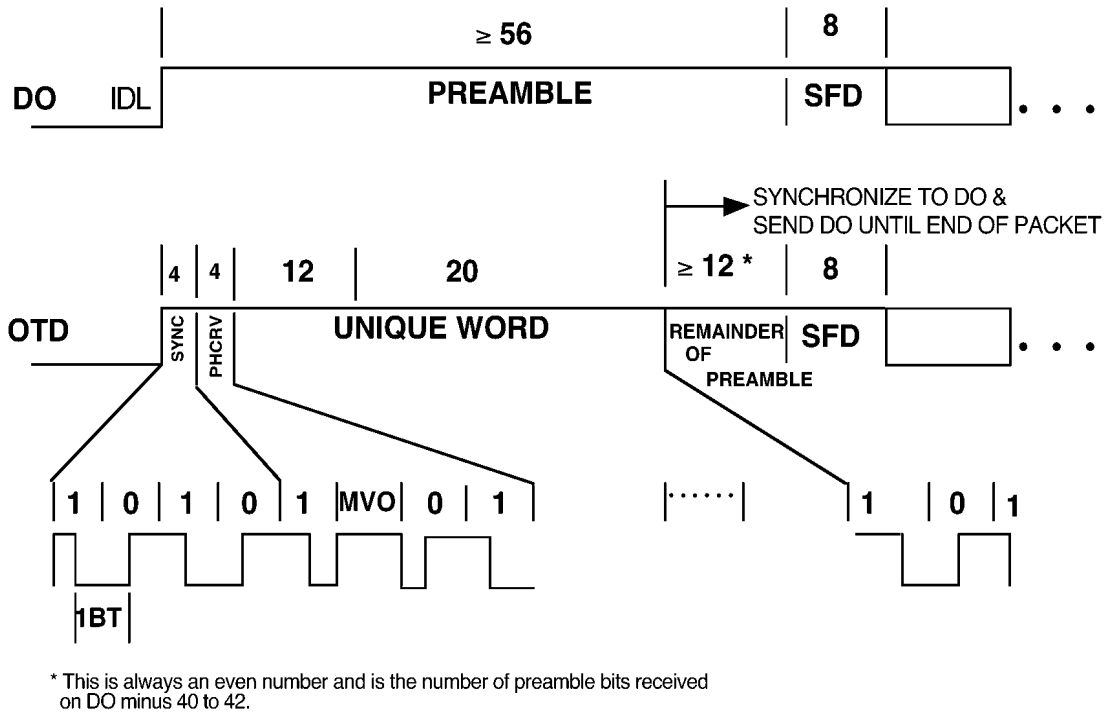


Figure 16–1—10BASE-FP MAU preamble encoding

### 16.2.2.3 OTD\_manch\_violation

The PMA shall send the *OTD\_manch\_violation* message whenever the Preamble Encoding function (16.3.1.1) or the Collision Encoding function (16.3.1.3) requires it to do so. The physical realization of the *OTD\_manch\_violation* message shall be an MVO signal sent by the PMA.

### 16.2.3 MDI ORD-to-PMA messages

The following messages can be received by the MAU PMA from the MDI ORD (Optical Receive Data) circuit:

Message	Circuit	Signal	Meaning
<i>ORD_input</i>	ORD	CD1, CD0	Input information
<i>ORD_idle</i>	ORD	RDARK	No information to input
<i>ORD_crv</i>	ORD	CRV	Detected Manchester violation

#### 16.2.3.1 ORD\_input

When the PMA sublayer receives the *ORD\_input* message on its ORD circuit, it detects a bit of data. The physical realization of the *ORD\_input* message shall be a CD0 or CD1 signal.

### 16.2.3.2 *ORD\_idle*

When the PMA sublayer receives the *ORD\_idle* message on its ORD circuit, it detects idle. The physical realization of the *ORD\_idle* message shall be an RDARK signal. RDARK shall be a signal with an optical level as specified in 15.2.1.4, Idle Signal Amplitude, and shall have a duration of 1.25 BT or greater.

### 16.2.3.3 *ORD\_crv*

When the PMA sublayer receives the *ORD\_crv* message on its ORD circuit, it detects a code rule violation. The physical realization of the *ORD\_crv* message shall be a CRV signal. CRV is defined in 15.1.2.

## 16.3 10BASE-FP MAU functional specifications

The MAU component provides the means by which signals on the DO and DI circuits are coupled:

- a) From the DTE or repeater to the MAU's transmit MDI, and
- b) From the MAU's receive MDI to the DTE or repeater.

Further, simultaneous transmissions from two or more MAUs are reported as a collision on the CI circuit.

To achieve this basic objective, the MAU component shall contain the following functional capabilities to handle message flow between the DTE or repeater and the MDI:

- Transmit function: Provides the ability to transmit serial data bit streams from the attached device into the MAU's transmit MDI.
- Receive function: Provides the ability to receive serial data bit streams from the MAU's receive MDI and transmit them to the attached device.
- Loopback function: Provides the ability to transfer serial data bit streams from the DO to the DI circuit when the MAU is sending data to the OTD circuit.
- Collision Presence function: Provides the ability to detect, and report to the attached device, a collision.
- *signal\_quality\_error* Message (SQE) Test function: Provides the ability to indicate to the DTE that the Collision Presence function is operational and that the *signal\_quality\_error* message can be sent by the MAU.
- Jabber function: Provides the ability to detect abnormally long data streams on the DO circuit and inhibit Data Transmit and Receive, SQE Test, Data Loopback, and the Collision Presence function.
- Link Fault Detection and Low Light function: Provides the ability to detect faults in the 10BASE-FP fiber optic segment and inhibit Data Transmit and Receive, SQE Test, Data Loopback, and the Collision Presence function.

### 16.3.1 Transmit function requirements

The function of the MAU transmitter shall be to transmit the data received at the DO circuit of the AUI onto the MDI. The Transmit function has four purposes:

- a) To convert the electrical signals to optical signals.
- b) To recode the preamble to guarantee collision detection.
- c) To generate a unique jam signal to facilitate deterministic end of collision detection.
- d) To retime signals received on the DO circuit.

The levels and timing of the optical signal shall be as specified in 15.2.1. When a packet is received at the DO interface, transmission of encoded preamble at the MDI shall begin within 5.5 BT. The first bit transmit-

ted onto the fiber from the MDI shall be a CD1 (see 16.3.1.1.1). The signaling rate at the MDI shall be 10 Mb/s  $\pm$  0.005%.

NOTE—The tolerance of  $\pm$ 0.005% simplifies the detection of data and collision in the MAU receiver. It may not be necessary to retiming signals in an embedded MAU.

### 16.3.1.1 Preamble encoding

The Transmit function shall replace the first 40 bits of preamble with a pattern consisting of a 4-bit synchronization pattern, a 4-bit packet header Manchester-coding violation pattern (see 16.3.1.1.2), and a 32-bit unique word (see 16.3.1.1.3) as shown in Figure 16–1. Following the unique word, the remainder of the preamble received on the DO shall be transmitted as received subject to the following rules:

- a) The encoded preamble shall be aligned with the preamble received from the DO circuit in such a way that the first bit of the remainder is a Manchester-encoded 1; i.e., the remainder of the preamble is CD1, CD0, CD1, CD0,....
- b) The number of bits of preamble received from the DO circuit and sent to the MDI prior to the transmission of SFD shall be no less than the total number received from the DO circuit minus 42 bits and no greater than the total number received from the DO circuit minus 40 bits. The above ensures that the preamble transmitted on the OTD circuit is no more than 2 bits shorter than the preamble received from the DO circuit.

The purpose of preamble encoding is to provide synchronization and collision detection information to the Receive function. This unique encoding exists only on the medium and is removed by the receiving MAU.

#### 16.3.1.1.1 Synchronization pattern

The synchronization pattern shall be a Manchester-encoded 1010 (SYNC=CD1 CD0 CD1 CD0). No other pattern, including 0101, is allowed.

#### 16.3.1.1.2 Packet header code rule violation

The packet header code rule violation pattern shall be a fixed, 4-bit pattern that contains a single violation of the Manchester coding rules. The pattern consists of a CD1, MV0, CD0, CD1. The single Manchester violation in the pattern is the only violation allowed in a properly transmitted packet.

#### 16.3.1.1.3 Unique word

The unique word shall be a 32-bit long Manchester-encoded data pattern that is used to guarantee that the preambles sent by any two 10BASE-FP MAUs are different. The word consists of a 12-bit Manufacturer ID assigned by the IEEE Registration Authority and a 20-bit 10BASE-FP MAU ID assigned by the manufacturer to ensure that the 32-bit word is unique. The nature of the Registration Authority<sup>33</sup> and the procedure by which it administers these 12-bit manufacturer identifiers is beyond the scope of this standard. Each of the elements of the unique word shall be transmitted least significant bit first, starting with the Manufacturer ID followed by the MAU ID.

### 16.3.1.2 Data transmit

The Data Transmit function shall receive the data signals on the DO circuit and send them on the MDI following the encoded preamble.

<sup>33</sup>For the purpose of assigning organizationally unique identifiers (OUIs), the Institute of Electrical and Electronics Engineers has been designated by the ISO Council as the Registration Authority. Communications on this subject should be addressed to the Registration Authority for ISO/IEC 8802-3, The Institute of Electrical and Electronics Engineers, 445 Hoes Lane, P.O. Box 1331, Piscataway, NJ 08855-1331 USA, tel. (732) 562-3813; fax (732) 562-1571. URL: <http://standards.ieee.org/>.

The steady-state delay between the DO circuit and transmission on the MDI at the time of the start bit in the SFD, shall be no more than 3.5 BT. The difference between start-of-packet propagation delay for any two packets that are separated by 9.6  $\mu$ s or less shall not exceed 3 BT.

### 16.3.1.3 Collision encoding (unique word jam)

After the start of collision (see 16.3.4.2), the Transmit function shall, within 3.5 BT, cease to send the encoded preamble or data from the DO circuit and shall send a repeating, unique, 33-bit pattern. This pattern shall consist of MV0 followed by the 32-bit unique word. In the presence of a collision, a MAU will detect at least two *ORD\_crv* within 33 BT and can thereby guarantee accurate detection of end of collision. This pattern shall be repeatedly transmitted at the MDI OTD until the MAU ceases to receive data on the DO circuit. When this occurs, the MAU shall begin sending *OTD\_idle* at the MDI within 3.5 BT of the last bit on the DO circuit.

### 16.3.2 Receive function requirements

The function of the MAU Receive function is to transmit the data received on the MDI ORD circuit into the DI circuit. The Receive function has three purposes:

- a) To convert optical signals to electrical signals.
- b) To replace the coded preamble with normal preamble as specified in 4.2.5.
- c) To provide uninterrupted carrier sense during collision presence.

The optical-to-electrical conversion shall be as specified in 15.2.2.3.

#### 16.3.2.1 Preamble reconstruction and alignment

When a packet is received on the MDI ORD circuit, transmission of the reconstructed preamble to the DI circuit shall begin within 2.5 BT. The difference between start-of-packet propagation delay for any two packets that are separated by 9.6  $\mu$ s or less shall not exceed 1 BT.

The reconstructed preamble shall consist of exactly 40 bits of standard preamble (CD1, CD0, CD1,...CD0) followed by the preamble remainder received on the ORD circuit. The Receive function shall align the preamble remainder such that the 41st bit transmitted on the DI circuit is a Manchester-encoded 1 (CD1).

#### 16.3.2.2 Data receive

The Data Receive function shall receive data signals on the MDI ORD circuit and send them into the DI circuit following the reconstructed preamble.

At the start of SFD reception at the MDI ORD circuit, the steady-state delay between the MDI ORD circuit and the DI circuit shall not exceed 2.5 BT.

#### 16.3.2.3 Signal presence during collision

When a collision is detected (see 16.3.4.2), the Receive function shall transmit Manchester Fill, a sequence of Manchester-encoded alternating CD1s and CD0s on the DI circuit. This Manchester sequence shall be sent on the DI circuit for the duration of activity on the MDI ORD circuit and shall be deasserted within 3 BT from the start of RDARK on the MDI ORD circuit. In addition, the data being sent to the DI circuit shall be monitored and altered to be a valid Manchester sequence if any sequence besides a valid Manchester sequence or RDARK is seen, in the absence of collision yet being signaled.



### 16.3.3 Loopback function requirements

The MAU shall transmit the bit stream received from the DO circuit into the DI circuit. At the start-of-packet transmission, no more than 2 bits of information shall be received from the DO circuit and not transmitted into the DI circuit. It is permissible for the first bit sent to contain encoded phase violations or invalid data. All successive bits shall be transmitted into the DI circuit and shall exhibit no more edge jitter than that specified for signals transmitted into the DI circuit by the Receive function, as specified in 15.2.2.2. The steady-state propagation delay between the DO circuit receiver input and the DI circuit driver output for such signals shall not exceed 1 BT. The MAU's DI circuit driver shall comply with the specification for AUI drivers in 7.4.1. There shall be no logical signal inversions between the DO circuit and the DI circuit during collision-free transmission.

### 16.3.4 Collision presence function requirements

#### 16.3.4.1 CI Circuit signaling

CI circuit signaling and timing shall meet the requirements of 7.3.1.2, as modified by 15.1.3.3, and 15.5.4.1.

#### 16.3.4.2 Collision detection

The MAU shall detect as a collision the following two cases (see Figure 16–6)

- a) DO becoming active while ORD is active, except for the instance where ORD is still active from a previous transmission's loopback from the star.
- b) The detection of a second *ORD\_crv* without an intervening *ORD\_idle*.

The start of collision is measured from the time DO becomes active in case a) above and from the occurrence of the second *ORD\_crv* for case b) above.

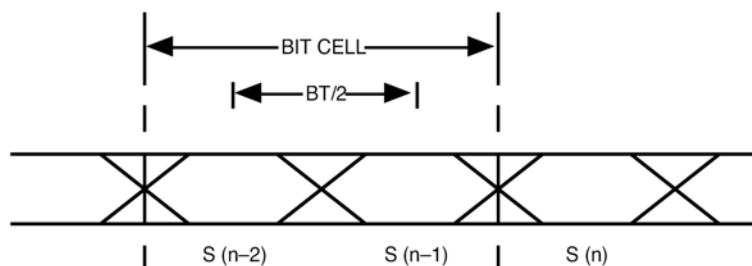
The MAU shall detect *ORD\_crv*'s over the received optical power ranges specified in 15.2.2.1. In addition, *ORD\_crv* detection shall occur over a differential power range of 8.0 dB.

While a collision is occurring, a CS0 (7.3.1.2) signal shall be sent on the CI circuit. The signal shall be presented to the CI circuit no more than 3.5 BT after start of collision.

If two or more packets arrive simultaneously at the MDI, then the MAU will receive the packet header *ORD\_crv* and at least one additional *ORD\_crv* during reception of the overlapping unique word patterns. Otherwise the MAU will receive the multiple packet header *ORD\_crv*'s from the interfering packet(s).

In order to meet the performance requirements, *ORD\_crv* detection needs to be performed in the analog portion of the receiver, as the amplitude information that is essential for *ORD\_crv* detection is lost after converting the analog signal into a digital (binary) waveform.

One possible way to detect *ORD\_crv* is to compare the amplitudes of three consecutive samples separated by one half BT. The samples are obtained by using a recovered 20 MHz receive clock as shown below.



The differences  $d1 = |S(n) - S(n-1)|$  and  $d2 = |S(n) - S(n-2)|$  are produced. The computation must be done once per bit cell, with  $S(n)$  being the sample from the first half of the bit cell. In a valid Manchester-encoded sequence, one of these differences must be zero. Thus, if both differences are above a certain threshold, a Manchester code rule violation (*ORD\_crv* message) is detected. The actual value of the threshold is implementation dependent but needs to be such that the probability of obtaining an *ORD\_crv* when two or more MAUs are sending simultaneously is 100% (also see 15.2.2). Also, at least one of  $S(n)$ ,  $S(n-1)$ , or  $S(n-2)$  must be HI.

The approach described above may not be the only approach that may meet the requirements for reliable collision detection through *ORD\_crv*. The implementor may choose any approach that satisfies the requirements.

NOTE—Implementors are cautioned that optical waveforms received during collisions are the superpositions of multiple transmitted waveforms and that any receive clock synchronization may then be undefined. Under these conditions, collisions will continue to be detected and indicated correctly.

#### 16.3.4.3 End of collision

After detection of a collision (16.3.4.2), CI shall send CS0 until (see Figure 16–2 and Figure 16–6<sup>34</sup>)

- a) Either DO becomes inactive,
- b) ORD becomes idle, or,
- c) After waiting for a delay of 54 BT for the unique word jam to loop back from the star, 33 BT have passed with no more than one *ORD\_crv*.

The CS0 signal shall be deasserted within 3 BT after any of the above conditions has occurred (see Figure 16–6).

The signal presented on the CI circuit in the absence of collision, SQE Test, or Jabber shall be the IDL signal.

NOTE—The Transmit function (16.3.1) encodes the signal transmitted to guarantee that

- a) All transmissions received without collision contain one and only one *ORD\_crv*.
- b) All transmissions received with collision contain more than one *ORD\_crv*.
- c) During a collision, spacing between *ORD\_crv* events is no more than 32 BT (UWJ has an MV0 every 33 BT).

If a collision is in progress, either the MV0s are in alignment and at least one additional *ORD\_crv* will occur during (and because of) the superposition of the unique words, or the MV0s are not in alignment and will be detected in each of the UWJs as *ORD\_crv*.

#### 16.3.5 signal\_quality\_error Message (SQE) Test function requirements

The SQE Test function shall be performed by MAUs connected to DTEs and shall not be performed by MAUs connected to repeaters. A capability may be provided in the MAU to activate or inhibit the SQE Test function. It is not required that a MAU determine that it is connected to either a DTE or a repeater and automatically activate or inhibit the SQE Test function. When the SQE test is performed, the MAU shall send CS0 on the CI circuit for a time “SQE\_test” beginning a time “SQE\_test\_wait” after the last positive transition of a packet on the DO circuit. The value of “SQE\_test” shall be 10 BT + 5 BT and the value of SQE\_test\_wait shall be between 0.6  $\mu$ s and 1.6  $\mu$ s. This function should use as much of the normal collision detection and signaling circuitry as possible without introducing extraneous signals on the OTD circuit or DI circuit.

#### 16.3.6 Jabber function requirements

The MAU shall contain a self-interrupting capability to prevent an illegally long transmission by the DTE from permanently disrupting transmission on the network (see Figure 16–5). If the transmission exceeds time “xmit\_max”, then Jabber shall be detected. The value of “xmit\_max” shall be in the range of 20 ms to 150 ms.

<sup>34</sup>The MAU state diagrams, Figures 16–2 through 16–6, follow 16.3.4.3.

Upon detection of the Jabber condition, the MAU shall perform the following:

- a) Disable Data Transmit,
- b) Send the CS0 signal on the CI circuit, and
- c) Disable the Loopback function (16.3.1.3) from the DO circuit to the DI circuit.

The MAU shall reset the Jabber function after a continuous period of IDL on the DO circuit of time “unjab”. The value of “unjab” shall be  $0.5 \text{ s} \pm 0.25 \text{ s}$ .

The MAU shall not activate its Jabber function when the repeater’s MAU Jabber Lockup Protection function operates at its longest permitted time as specified in 9.6.5.

NOTE—It is recommended that the Jabber function be activated when the OTD circuit transmitter is sending *OTD\_output* messages for longer than the value of “xmit\_max\_timer”.

### 16.3.7 Link fault detection and low light function requirements

The MAU shall have the capability, as defined in Figure 16–4, to detect faults in the passive fiber optic segment that may affect the reliable carrier sense required by the CSMA/CD access method. The Link Fault Detection and Low Light function ascertains the integrity of the link, during packet transmission, by detecting the presence, at the MDI ORD circuit, of an optical signal that meets the requirements of 15.2.2.1 returned from the star. The MAU shall detect a Link Fault if, after the start of a packet onto the OTD circuit, time “link\_test” elapses with no optical signal having been received on the ORD circuit. The value of “link\_test” shall be  $10 \mu\text{s} \pm 2.5 \mu\text{s}$ . A Link Fault shall also be detected if the optical power of a received optical signal is not sufficient to maintain a BER of one part in  $10^7$ .

On detection of the Link Fault condition, the MAU shall perform the following:

- a) Disable its Data Transmit,
- b) Disable its Data Receive, and
- c) Disable the Loopback (16.3.1.3) from the DO circuit to the DI circuit.

The MAU shall reset the Link Fault function after time “link\_heal”, followed by the presence of an optical signal on the ORD circuit having sufficient optical power to maintain a BER of one part in  $10^7$ , and then followed by DO circuit and ORD circuit becoming idle. The value of “link\_heal” shall be  $0.5 \text{ s} \pm 0.25 \text{ s}$ .

The Link Fault state diagram (Figure 16–4) controls the measurement of optical loopback time. The value for link\_test has been chosen to ensure that a correctly operating 10BASE-FP MAU attached to a 10BASE-FP Star via an unbroken fiber pair 500 m long will always exit the START LINK TEST state before link\_test\_timer\_done is asserted.

When not transmitting, and not receiving idle, if the optical power of the received optical signal is not sufficient to maintain a BER of one part in  $10^7$ , the MAU shall set CRV to *true* and send the *ORD\_crv* message.

### 16.3.8 Interface message time references

Delay and bit loss specifications are measured from the occurrence of messages at the MDI and MAU AUI. A “positive-going” transition is from LO to HI. The following describes the point where each message starts:

Message	Reference
<i>output</i>	leading bit cell boundary (BCB) of first valid CD1 or CD0
<i>output_idle</i>	last positive-going transition prior to start of IDL
<i>input</i>	leading BCB of first valid CD1 or CD0
<i>input_idle</i>	last positive-going transition prior to start of IDL.
<i>signal_quality_error</i>	first transition of valid amplitude
<i>mau_available</i>	last positive-going transition prior to start of IDI
<i>OTD_output</i>	leading BCB of first (valid) CD1 or CD0
<i>OTD_idle</i>	last positive-going transition prior to start of TDARK
<i>OTD_manch_violation</i>	leading BCB of valid MV0
<i>ORD_input</i>	leading BCB of first (valid) CD1 or CD0
<i>ORD_idle</i>	last positive-going transition prior to start of RDARK
<i>ORD_crv</i>	leading BCB of a Manchester code rule violated bit

### 16.3.9 MAU state diagram

The state diagrams, Figure 16–2 through Figure 16–6, depict the full set of allowed MAU state functions relative to the circuits of the AUI and MDI.

The notation used in the state diagrams follows the conventions in 1.2.1. The variables, timers, and counters used in the state diagrams are defined in the following subclauses.

#### 16.3.9.1 MAU state diagram variables

Variables are used in the state diagrams to indicate the status of MAU inputs and outputs, to control MAU operation, and to pass state information between functions.

In the variable definitions, the name of the variable is followed by a brief description of the variable and a list of values the variable may take. For those variables that are state diagram outputs, one value will be identified as the default. The variable has the default value when no active state contains a term assigning a different value.

The variables used in the state diagrams are as follows:

begin

The interprocess flag controlling state diagram initialization values.

Values: false (default).

true.

## DI

Controls the signal sent by the MAU on the DI circuit.  
 Values: *idle*; MAU sends *input\_idle*, IDL (default)  
 DO; MAU sends the signal received on the DO circuit.  
 Manchester fill; (16.3.2.3).  
 ORD; MAU sends the Manchester-encoded data received on the ORD circuit.  
 STANDARD PREAMBLE; MAU sends CD1 CD0 CD1 CD0 etc., preamble as defined in 4.2.5  
 and described in 16.3.2.1.

## CI

Controls the signal sent by the MAU on the CI circuit.  
 Values: *idle*; MAU sends *mau\_available*, IDL (default).  
 SQE; MAU sends *signal\_quality\_error*, CS0.

## DO

Status of the signal received by the MAU on the DO circuit.  
 Values: *idle*; MAU receives *output\_idle*, IDL.  
 active; MAU receives output, CD0 or CD1.

## OTD

Controls the signal sent by the MAU on the OTD circuit.  
 Values: *idle*; MAU sends TDARK (default).  
 MP; MAU sends MODIFIED PREAMBLE (16.3.1.1).  
 DO; MAU sends the Manchester-encoded data received on the DO circuit.  
 UWJ; MAU sends UNIQUE WORD JAM (16.3.1.3).

## ORD

Status of the signal received by the MAU on the ORD circuit.  
 Values: *idle*; MAU receives RDARK.  
 active; MAU receives CD0, CD1 or CRV.

## jab

Interprocess variable that indicates whether a jabber has been detected.  
 Values: *not\_detect*; jabber not detected (default).  
*detect*; jabber detected.

## link\_status

Interprocess variable that indicates whether a link fault has been detected.  
 Values: *good*; no link fault detected (default).  
*bad*; link fault detected.

## col\_status

Interprocess variable that indicates whether a CRV (*ORD\_crv*) was received near the  
 beginning of a received packet.  
 Values: *good*; no CRV fault detected (default).  
*fault*; CRV fault detected.

## status

Interprocess variable that indicates if a CRV fault, link fault or a jabber is detected.  
 Values: *ok*; *link\_status=good \* jab=not\_detect \* col\_status=good*.  
*fault*; *link\_status=bad + jab=detect + col\_status=fault*.

collision

Status of the Collision Detect function.  
Values: false; no collision detected (default).  
true; collision detected (16.3.4.2).

E\_col

Status indicating that a collision was detected in the electrical domain.  
Values: false; no electrical collision detected (default).  
true; electrical collision detected.

CRV

Status of the code rule violation detector.  
Values: false; no code rule violation.  
true; a code rule violation has occurred.

SQE\_test

A capability may be provided in the MAU to activate or inhibit the SQE Test function. It is not required that a MAU determine that it is connected to either a DTE or a repeater and automatically activate or inhibit the SQE Test function.  
Values: false; MAU is connected to a repeater.  
true; MAU is connected to a DTE.

MPT

Status indicator for transmission of Modified Preamble.  
Values: not done; Modified Preamble being transmitted.  
done; transmission of Modified Preamble complete.

MPR

Status indicator for reception of Modified Preamble.  
Values: not done; Modified Preamble being received.  
done; reception of Modified Preamble complete.

low\_light

Status indicator for low light detection.  
Values: false; low\_light not detected (16.3.7).  
true; low\_light detected (16.3.7).

### 16.3.9.2 MAU state diagram timers

All timers operate in the same fashion. A timer is reset and starts counting upon entering a state where “start x\_timer” is asserted. At time “x” after the timer has been started, “x\_timer\_done” is asserted and remains asserted until the timer is reset. At all other times “x\_timer\_not\_done” is asserted.

When entering a state where “start x\_timer” is asserted, the timer is reset and restarted even if the entered state is the same as the exited state.

The timers used in the MAU state diagrams are defined as follows:

**link\_test\_timer.** The timer for longest time between start of DO and start of ORD before Link Fault state is entered (16.3.7).

**link\_heal\_timer.** The timer that defines the time delay from Link Fault detection to start of qualification procedure that resets link\_fault (16.3.7 and Figure 16-4).

**SQE\_test\_timer.** The timer for the duration of the Signal Quality Error test signal (16.3.5).

**SQE\_test\_wait\_timer.** The timer for the delay from end of packet to the start of the SQE test signal (16.3.5).

**xmit\_max\_timer.** The timer for excessively long transmit time (16.3.6).

**unjab\_timer.** The timer for the length of time the DO circuit must be continuously idle to allow transmission to be re-enabled (16.3.6).

### 16.3.9.3 MAU state diagram counters

All counters operate in the same fashion. A counter is reset (set to zero) upon entering a state where “start\_x\_cntr” is asserted. The counter then increments each time the associated event occurs until the counter reaches its maximum value.

The counters used in the MAU state diagrams are defined as follows:

**CRV\_cntr.** Counts the number of CRVs. Used to differentiate between collision and UWJ. *Values:* Integers between and including 0 and 2.

**EOC\_cntr.** Counts the number of BTs since last CRV. Used to identify end of collision (when EOC\_cntr = 33). *Values:* Integers between and including 0 and 33.

**DELAY\_cntr.** Counts BTs. Used to control the state transition after receiving MV0 in the preamble as a CRV. *Values:* Integers between and including 0 and 108.





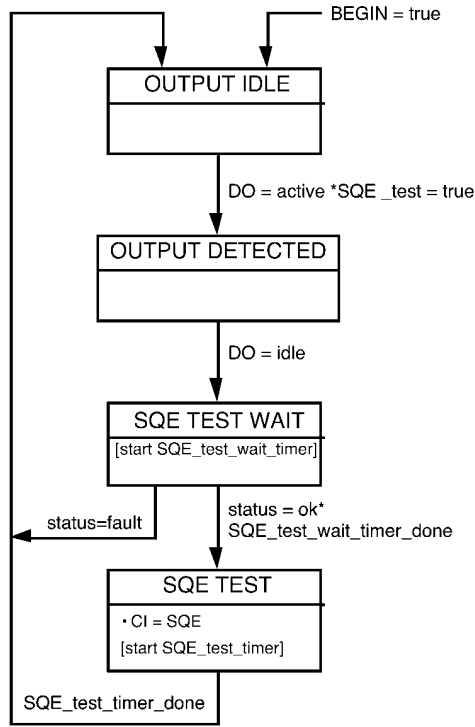


Figure 16-3—*signal\_quality\_error* Message Test function state diagram

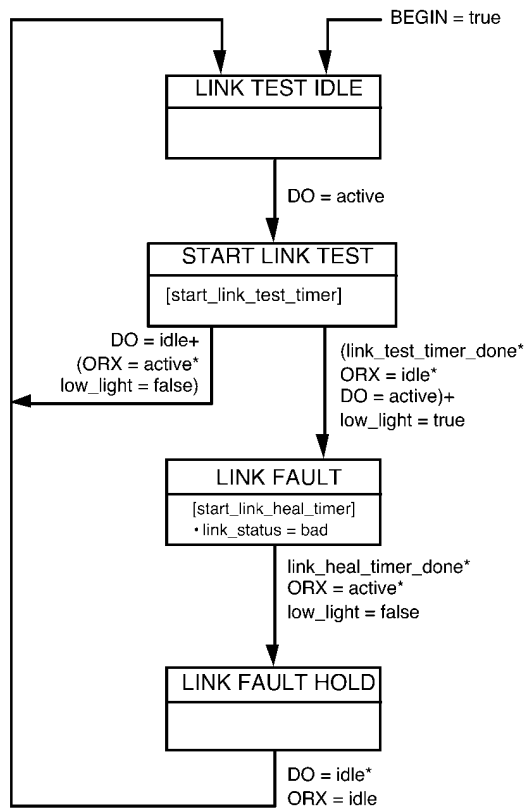


Figure 16-4—Link fault state diagram

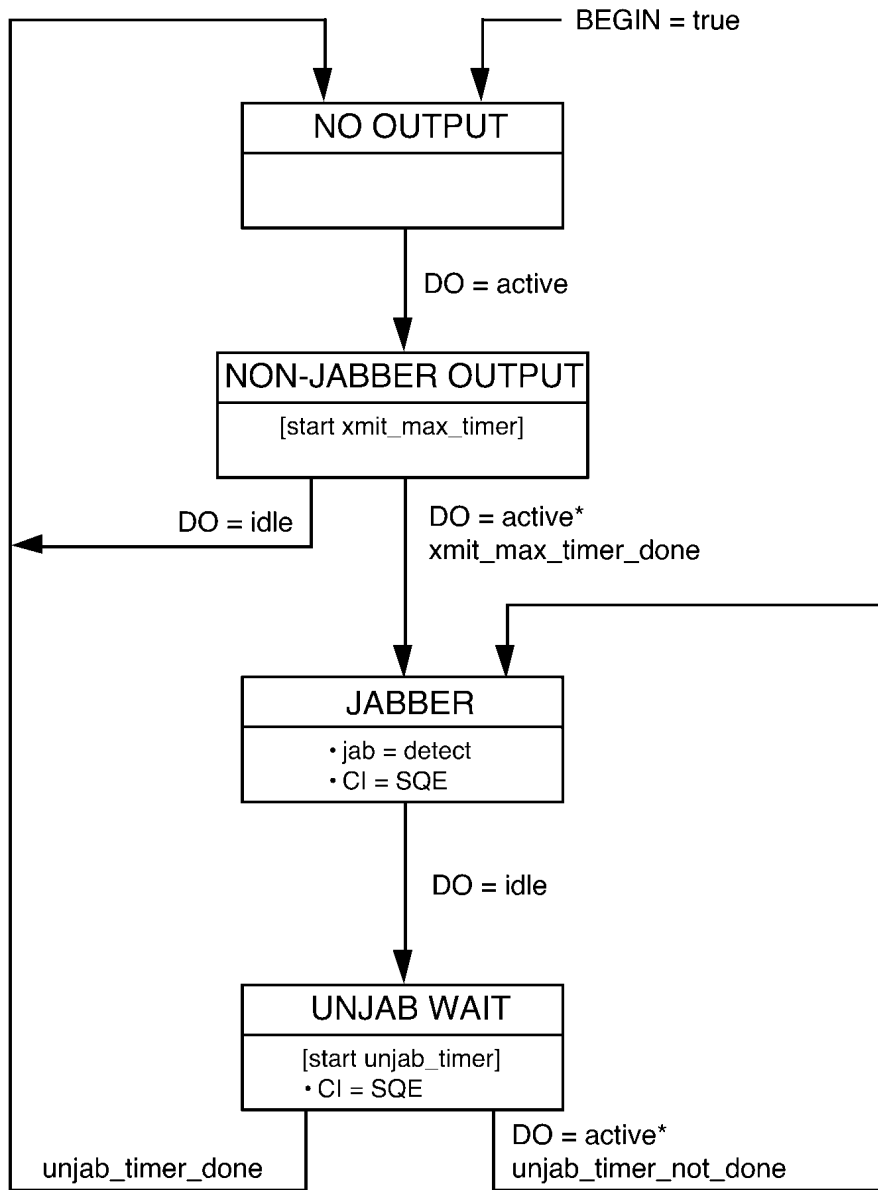


Figure 16-5—Jabber function state diagram

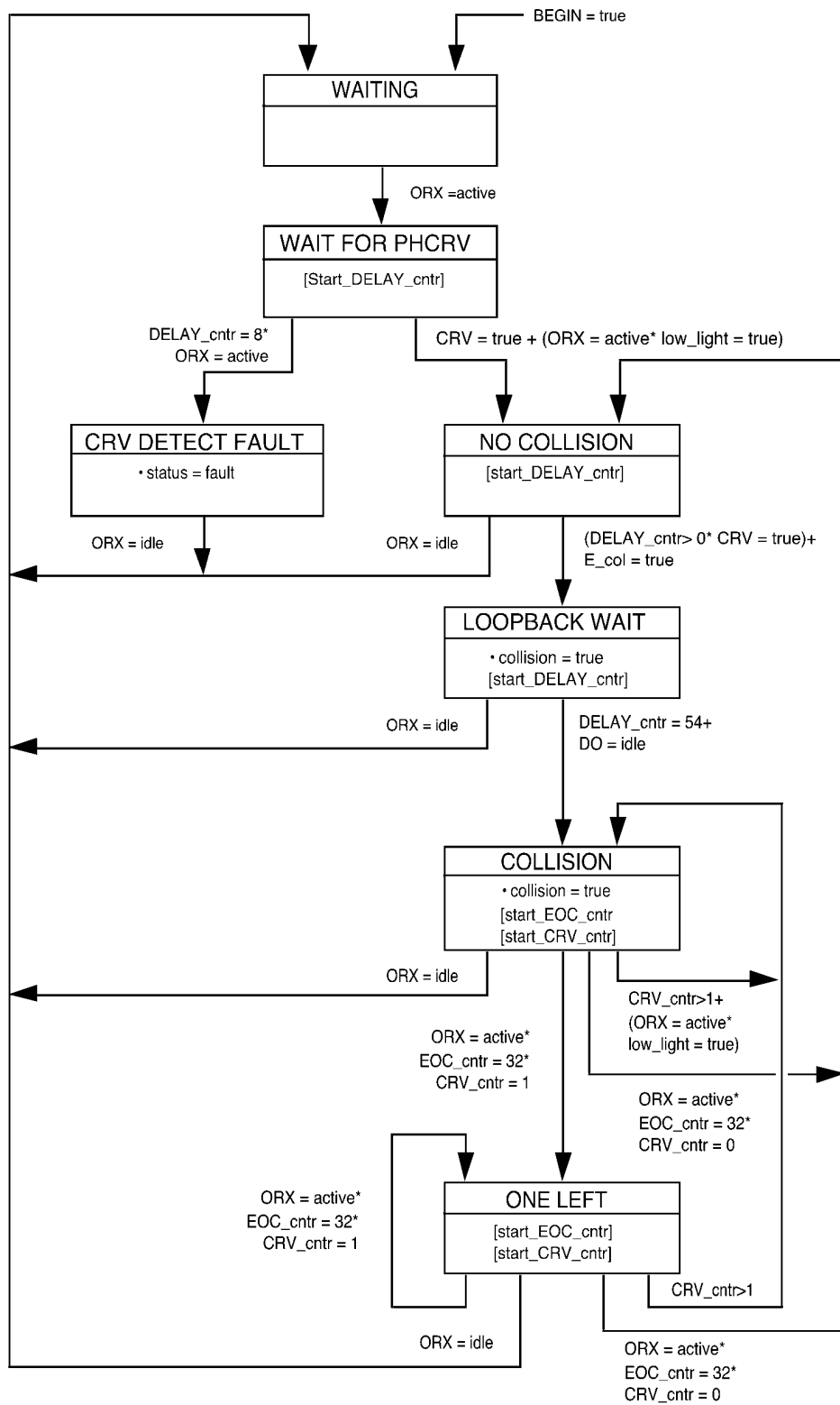


Figure 16–6—Collision detect state diagram

## 16.4 Timing summary

Table 16–1 summarizes the timing requirements for 10BASE-FP. This table is a summary; for complete descriptions of the timing to the referenced subclauses. All times are in bit times (BT).

**Table 16–1—Maximum timing parameters**

Symbol	Function	Bit loss	Invalid bits	Steady-state prop. delay	Start-up delay		
					Max.	Var.	Specified in
M1	<i>ORD_input</i> to <i>input</i> on DI	0.0	0.0	2.5	2.5	1.0	16.3.2
M2	<i>output</i> on DO to <i>OTD_output</i>	2.0	0.0	3.5	5.5	3.0	16.3.1
M3	non-looped-back <i>ORD_input</i> , and then <i>output</i> on DO, to <i>signal_quality_error</i> or two <i>ORD_crv</i> , without intervening <i>ORD_idle</i> , to <i>signal_quality_error</i>				3.5		16.3.4.2
M4a	33 BT with only one <i>ORD_crv</i> to <i>mau_available</i>			3.0			16.3.4.3
M4b	non-looped-back <i>ORD_input</i> , and then <i>output</i> on DO, to UWJ as <i>OTD_output</i>				3.5		16.3.1.3
M5	while transmitting: two <i>ORD_crv</i> , without intervening <i>ORD_idle</i> , to UWJ as <i>OTD_output</i>			3.5			16.3.1.3
M6	while UWJ as <i>OTD_output</i> : <i>output_idle</i> to <i>OTD_idle</i>			3.5			16.3.1.3
M7	<i>output_idle</i> on DO to <i>signal_quality_error</i>			6 to 16			16.3.5
M8	<i>signal_quality_error</i> duration for SQE test			5 to 15			16.3.5
M9	<i>output</i> on DO to <i>input</i> on DI	2.0	1.0	1.0	4.0		16.3.3
F1	Fiber Optic Cable Propagation (1000 m)	0	0	50	50		15.3.1.3
A1	AUI Cable Propagation (50 m)	0	0	2.57	2.57		7.4.3.7

## 16.5 10BASE-FP Star functional specifications

The 10BASE-FP Star provides a means by which the optical signal output from any 10BASE-FP MAU is coupled to the inputs of all 10BASE-FP MAUs attached to the same 10BASE-FP fiber optic segment.

### 16.5.1 Star functions

#### 16.5.1.1 Number of ports

A star may contain any number of input/output optical interfaces as long as the requirements of 16.5.2 are met.

#### 16.5.1.2 Optical power division

A star shall divide optical power incident on an input port uniformly (within the limits defined in 16.5.2.2) among all output ports without any amplification of the input optical signal.

### 16.5.1.3 Configuration

A 10BASE-FP fiber optic segment is configured by attaching a fiber pair between each MAU MDI and a star optical interface. Each MAU OTD circuit shall be connected to an input port of the star, and each MAU ORD circuit shall be connected to an output port. It is recommended for media management purposes to use each output port of the star with its corresponding input port.

### 16.5.1.4 Reliability

The star shall be designed to provide an MTBF of at least 10 million hours of continuous operation without causing a communication failure among stations attached to the network medium.

## 16.5.2 Star optical characteristics

### 16.5.2.1 Star insertion loss

The insertion loss between each input/output optical interface (including the loss of one connector pair) shall be in the range 16 dB to 20 dB, when measured in accordance with ANSI/EIA/TIA 455-180-1990 [B11] using the optical fiber, wavelength, and connector specifications of 15.2.1.1, 15.2.1.2, 15.3.1, and 15.3.2. This insertion loss can generally be met by a star with 33 or fewer input/output optical interfaces. Small-port-count stars may need attenuation in addition to that of the star coupler in order to meet this requirement. A star with more than 33 input/output optical interfaces is not precluded as long as the insertion loss, uniformity, and directivity requirements of this subclause, 16.5.2.2, and 16.5.2.3 are met.

NOTE—The mixing segment insertion loss specified in 15.3.3.1 is generally met by a 33-port star coupler constructed from optical fiber (15.3.1) with connectors (15.3.2) and up to 500 m of optical fiber (15.3.1) on each port. Different sizes and grades of fiber and star coupler may also meet this insertion loss and, while not prohibited, are beyond the scope of this standard.

### 16.5.2.2 Star single output port uniformity

Single output port uniformity is defined to be the difference between the maximum and minimum insertion loss values (measured according to 16.5.2.1) of any given output port and all input ports. Star single output port uniformity for each output port shall be less than 2.5 dB.

NOTE—Optical uniformity of a star refers to the variation in insertion loss of all input/output port combinations. In the 10BASE-FP system, the uniformity requirement is determined by the receiver. The variation between any given output port and all the input ports needs to be specified. Therefore, it is recommended that each output port connection remain constant during the insertion loss measurements involving that output port. This single output port uniformity is typically better than the overall uniformity of the star.

### 16.5.2.3 Star directivity

Directivity is the portion of light which is incident on an input port that appears as light emitted from another input port. For the star, directivity for all input optical interface combinations shall be greater than 35 dB. Directivity is measured in accordance with ANSI/EIA/TIA 455-180-1990 [B11] using the optical fiber and wavelength specifications of 15.2.1.1, 15.2.1.2, and 15.3.1.

NOTE—Although passive-star couplers are bidirectional (i.e., light can be transmitted in both directions on one fiber simultaneously), a 10BASE-FP Star cannot use this attribute to support two LANs simultaneously.

## 16.6 Protocol implementation conformance statement (PICS) proforma for Clause 16, Fiber optic passive star and medium attachment unit, type 10BASE-FP<sup>35</sup>

### 16.6.1 Introduction

The supplier of a protocol implementation that is claimed to conform to Clause 16, Fiber optic passive star and medium attachment unit, type 10BASE-FP, shall complete the following protocol implementation conformance statement (PICS) proforma.

A completed PICS proforma is the PICS for the implementation in question. The PICS is a statement of which capabilities and options of the protocol have been implemented. The PICS can be used for a variety of purposes by various parties, including the following:

- As a checklist by the protocol implementor, to reduce the risk of failure to conform to the standard through oversight;
- As a detailed indication of the capabilities of the implementation, stated relative to the common basis for understanding provided by the standard PICS proforma, by the supplier and acquirer, or potential acquirer, of the implementation;
- As a basis for initially checking the possibility of interworking with another implementation by the user, or potential user, of the implementation (note that, while interworking can never be guaranteed, failure to interwork can often be predicted from incompatible PICSs);
- As the basis for selecting appropriate tests against which to assess the claim for conformance of the implementation, by a protocol tester.

### 16.6.2 Abbreviations and special symbols

#### 16.6.2.1 Status symbols

The following symbols are used in the PICS proforma:

M	mandatory field/function
O	optional field/function
O.<n>	is optional field/function, but at least one of the group of options labeled by the same numeral <n> is required
O/<n>	is optional field/function, but one and only one of the group of options labeled by the same numeral <n> is required
X	is prohibited field/function
<item>:	is simple-predicate condition, dependent on the support marked for <item>

#### 16.6.2.2 Abbreviations

N/A	not applicable
-----	----------------

### 16.6.3 Instructions for completing the PICS proforma

#### 16.6.3.1 General structure of the PICS proforma

The first part of the PICS proforma, Implementation Identification and Protocol Summary, is to be completed as indicated with the information necessary to identify fully both the supplier and the implementation.

<sup>35</sup>Copyright release for PICS proformas: Users of this standard may freely reproduce the PICS proforma in this subclause so that it can be used for its intended purpose and may further publish the completed PICS.

The main part of the PICS proforma is a fixed-format questionnaire divided into subclauses, each containing a group of items. Answers to the questionnaire items are to be provided in the right-most column, either by simply marking an answer to indicate a restricted choice (usually Yes, No, or Not Applicable), or by entering a value or a set or range of values. (Note that there are some items where two or more choices from a set of possible answers can apply; all relevant choices are to be marked.)

Each item is identified by an item reference in the first column; the second column contains the question to be answered; the third column contains the reference or references to the material that specifies the item in the main body of the standard; the fourth column contains values and/or comments pertaining to the question to be answered. The remaining columns record the status of the item—whether the support is mandatory, optional, or conditional—and provide the space for the answers; see also 16.6.3.4 below.

The supplier may also provide, or be required to provide, further information, categorized as either Additional Information or Exception Information. When present, each kind of further information is to be provided in a further subclause of items labeled A<i> or X<i>, respectively, for cross-referencing purposes, where <i> is any unambiguous identification for the item (e.g., simply a numeral); there are no other restrictions on its format or presentation.

A completed PICS proforma, including any Additional Information and Exception Information, is the protocol implementation conformance statement for the implementation in question.

Note that where an implementation is capable of being configured in more than one way, according to the items listed under 16.6.5, Major Capabilities/Options, a single PICS may be able to describe all such configurations. However, the supplier has the choice of providing more than one PICS, each covering some subset of the implementation's configuration capabilities, if that would make presentation of the information easier and clearer.

### **16.6.3.2 Additional information**

Items of Additional Information allow a supplier to provide further information intended to assist the interpretation of the PICS. It is not intended or expected that a large quantity will be supplied, and the PICS can be considered complete without any such information. Examples might be an outline of the ways in which a (single) implementation can be set up to operate in a variety of environments and configurations; or a brief rationale, based perhaps upon specific application needs, for the exclusion of features which, although optional, are nonetheless commonly present in implementations of the 10BASE-FP protocol.

References to items of Additional Information may be entered next to any answer in the questionnaire, and may be included in items of Exception Information.

### **16.6.3.3 Exception information**

It may occasionally happen that a supplier will wish to answer an item with mandatory or prohibited status (after any conditions have been applied) in a way that conflicts with the indicated requirement. No pre-printed answer will be found in the Support column for this; instead, the supplier is required to write into the Support column an X<i> reference to an item of Exception Information, and to provide the appropriate rationale in the Exception item itself.

An implementation for which an Exception item is required in this way does not conform to this standard.

Note that a possible reason for the situation described above is that a defect in the standard has been reported, a correction for which is expected to change the requirement not met by the implementation.

### 16.6.3.4 Conditional items

The PICS proforma contains a number of conditional items. These are items for which both the applicability of the item itself, and its status if it does apply—mandatory, optional, or prohibited—are dependent upon whether or not certain other items are supported.

Individual conditional items are indicated by a conditional symbol of the form “<item>:<s>” in the Status column, where “<item>” is an item reference that appears in the first column of the table for some other item, and “<s>” is a status symbol, M, O, or X.

If the item referred to by the conditional symbol is marked as supported, the conditional item is applicable, and its status is given by “<s>”; the support column is to be completed in the usual way. Otherwise, the conditional item is not relevant and the Not Applicable (N/A) answer is to be marked.

Each item whose reference is used in a conditional symbol is indicated by an asterisk in the Item column.

### 16.6.4 Identification

#### 16.6.4.1 Implementation identification

Supplier	
Contact point for queries about the PICS	
Implementation Name(s) and Version(s)	
Other information necessary for full identification—e.g., name(s) and version(s) for machines and/or operating systems; System Name(s)	
<p>NOTE 1—Only the first three items are required for all implementations; other information may be completed as appropriate in meeting the requirements for the identification.</p> <p>NOTE 2—The terms Name and Version should be interpreted appropriately to correspond with a supplier’s terminology (e.g., Type, Series, Model).</p>	

#### 16.6.4.2 Protocol summary

Identification of protocol specification	IEEE Std 802.3-2008, Clause 16, Fiber optic passive star and medium attachment unit, type 10BASE-FP
Identification of amendments and corrigenda to this PICS proforma which have been completed as part of this PICS	
<p>Have any Exception items been required?      No [ ]      Yes [ ] (See 17.5.3.3; The answer Yes means that the implementation does not conform to IEEE Std 802.3-2008.)</p>	

Date of statement	
-------------------	--



**16.6.5 Major capabilities/options**

Item	Feature	Reference	Value/Comment	Status	Support
*DTE	MAU supports DTE connections	15.1.1	N/A	O.1	Yes [ ] No [ ]
*RPT	MAU supports repeater connections	15.1.1	N/A	O.1	Yes [ ] No [ ]
*AUI	AUI connection physically exists and is accessible for test	15.1.3.2	N/A	O	Yes [ ] No [ ]

**16.6.6 PICS proforma for the type 10BASE-FP MAU****16.6.6.1 Compatibility considerations**

Item	Feature	Subclause	Value/Comment	Status	Support
CC1	Compatibility Considerations: 10BASE-FP Systems compatible at 10BASE-FP MDI	15.1.3.2		M	Yes [ ]
CC2	Mode of operation	15.1.3.5	normal mode only	M	Yes [ ]

### 16.6.6.2 Optical transmit parameters

Item	Feature	Subclause	Value/Comment	Status	Support
OT1	Center Wavelength	15.2.1.1	min 800 nm max 910 nm	M	Yes [ ]
OT2	Spectral Width (FWHM)	15.2.1.2	< 75 nm	M	Yes [ ]
OT3	Optical Modulation Extinction Ratio	15.2.1.3	< -13 dB	M	Yes [ ]
OT4	Optical Idle Signal Amplitude	15.2.1.4	< 57 dBm	M	Yes [ ]
OT5	Optical Transmit Pulse Logic Polarity	15.2.1.5	High Optical Power = LO on AUI DO and MDI. Low Optical Power = HI on AUI DO and MDI.	M	Yes [ ]
OT6	Optical Transmit Pulse Rise and Fall times Max. (Data) Min. (Data) Max. Difference (Data)	15.2.1.6	Measured from 10% to 90% level		
OT7			10.0 ns	M	Yes [ ]
OT8			2.0 ns	M	Yes [ ]
			3.0 ns	M	Yes [ ]
OT9	Optical Transmit Pulse Overshoot	15.2.1.7	< 5%	M	Yes [ ]
OT10	Optical Transmit Pulse Undershoot	15.2.1.7	< 5%	M	Yes [ ]
OT11	Optical Transmit Pulse Edge Jitter, Total at MDI (Data)	15.2.1.8	± 1.0 ns Measured as in 15.2.1.8	M	Yes [ ]
OT12	Optical Transmit Pulse Duty Cycle Distortion (Data)	15.2.1.9	± 1.0 ns max Measured at median power level	M	Yes [ ]
OT13	Optical Transmit Average Power Min. Max.	15.2.1.10			
OT14			-15 dBm -11 dBm	M M	Yes [ ] Yes [ ]
OT15	Transmit signal template	Figure 15-3	Optical signal within template	M	Yes [ ]

**16.6.6.3 Optical receive parameters**

Item	Feature	Subclause	Value/Comment	Status	Support
OR1	BER between two AUIs attached to a single segment	15.2.2	< one part in 10 <sup>9</sup>	M	Yes [ ]
OR2 OR3	Optical Receive Average Power Min. Max.	15.2.2.1	When a single transmitter transmits on the medium –41.0 dBm –27.0 dBm	M M	Yes [ ] Yes [ ]
OR4	MAU optical receive Edge Jitter (Data) Received at MDI	15.2.2.2	± 4.5 ns at median power. Measured as in 15.2.2.2.	M	Yes [ ]
OR5	Optical Receive Pulse Logic Polarity	15.2.2.3	High Optical Power = LO on AUI DI and MDI. Low Optical Power = HI on AUI DI and MDI.	M	Yes [ ]
OR6 OR7	Optical Receive Pulse Rise and Fall Times: Max. (Data) Min. (Data)	15.2.2.4	Measured from 10% to 90% level  18.5 ns 2.0 ns	M M	Yes [ ] Yes [ ]

**16.6.6.4 Optical medium connector plug and socket**

Item	Feature	Subclause	Value/Comment	Status	Support
CS1	Connector Socket	15.3.2	BFOC/2.5—see IEC 60874-10:1992	M	Yes [ ]

**16.6.6.5 MAU functions**

Item	Feature	Subclause	Value/Comment	Status	Support
MF1	Transmit	16.3.1		M	Yes [ ]
MF2	Data Loopback	16.3.3		M	Yes [ ]
MF3	Receive	16.3.2		M	Yes [ ]
MF4	Collision Presence	16.3.4		M	Yes [ ]
MF5	Jabber	16.3.6		M	Yes [ ]
MF6	Link Fault Detection	16.3.7		M	Yes [ ]
MF7	Low Light Detection	16.3.7		M	Yes [ ]
MF8	SQE Test	16.3.5		DTE: M	N/A [ ] M: Yes [ ]
				RPT: X	N/A [ ] X: Yes [ ]

**16.6.6.6 PMA interface messages**

Item	Feature	Subclause	Value/Comment	Status	Support
PIM1	Messages between DTE or repeater PLS and MAU PMA	16.2	As in 7.2.1 and 15.5.4	M	Yes [ ]

### 16.6.6.7 PMA to MDI OTD messages

Item	Feature	Subclause	Value/ Comment	Status	Support
OTD1	Signal sent on OTD corresponding to <i>OTD_output</i> message	16.2.2.1	CD1,CD0	M	Yes [ ]
OTD2	Signal sent on OTD corresponding to <i>OTD_idle</i> message	16.2.2.2	TDARK	M	Yes [ ]
OTD3	TDARK optical level	16.2.2.2	As in 15.2.1.4	M	Yes [ ]
OTD4	TDARK duration	16.2.2.2	≥ 1.5 BT	M	Yes [ ]
OTD5	Signal sent on OTD to ensure detection of collisions: <i>OTD_manch_violation</i> message	16.2.2.3	MV0	M	Yes [ ]

### 16.6.6.8 MDI ORD to PMA messages

Item	Feature	Subclause	Value/ Comment	Status	Support
OTD1	Signal received on ORD corresponding to <i>ORD_input</i> message	16.2.3.1	CD1,CD0	M	Yes [ ]
OTD2	Signal received on ORD corresponding to <i>ORD_idle</i> message	16.2.3.2	RDARK	M	Yes [ ]
OTD3	RDARK Optical Level	16.2.3.2	As in 15.2.1.4	M	Yes [ ]
OTD4	RDARK Duration	16.2.3.2	≥ 1.25 BT	M	Yes [ ]
OTD5	Signal received on ORD corresponding to <i>ORD_crv</i> message	16.2.3.3	CRV	M	Yes [ ]

### 16.6.6.9 Transmit functions

Item	Feature	Subclause	Value/Comment	Status	Support
XT1	Signaling rate	16.3.1	10 Mb/s ± 0.005%	M	Yes [ ]
XT2	Optical transmit levels and timing	16.3.1	As in 15.2.1	M	Yes [ ]
XT3	Transmit start-up delay	16.3.1	≤ 5.5 BT	M	Yes [ ]
XT4	First bit transmitted	16.3.1	CD1	M	Yes [ ]
XT5	Transmit path	16.3.1	DO circuit to transmit MDI	M	Yes [ ]
XT6	Preamble encoding	16.3.1.1	Replace first 40 bits of preamble with pattern as described	M	Yes [ ]
XT7	Remainder of preamble	16.3.1.1	Transmitted as received	M	Yes [ ]
XT8	Alignment of remainder of preamble	16.3.1.1	CD1,CD0,...	M	Yes [ ]

**16.6.6.9 Transmit functions (continued)**

XT9	Number of preamble bits received from DO and sent to the transmit MDI prior to transmission of SFD	16.3.1.1	$\geq$ total number received from DO minus 42 bits and $\leq$ total number received from DO minus 40 bits	M	Yes [ ]
XT10	Synchronization pattern	16.3.1.1.1	CD1,CD0,CD1,CD0	M	Yes [ ]
XT11	Packet header code rule violation	16.3.1.1.2	CD1,MV0,CD0,CD1	M	Yes [ ]
XT12	Unique Word	16.3.1.1.3	32 bit word as described	M	Yes [ ]
XT13	Unique Word order of transmission	16.3.1.1.3	Least significant bit first	M	Yes [ ]
XT14	Data transmit	16.3.1.2	Following preamble, all data received from DO is sent to transmit MDI	M	Yes [ ]
XT15	Transmit steady-state delay	16.3.1.2	3.5 BT max	M	Yes [ ]
XT16	Transmit delay variability	16.3.1.2	3 BT max for packets $\leq 9.6 \mu\text{s}$ apart	M	Yes [ ]

**16.6.6.10 Collision Encoding (Unique Word Jam) function**

Item	Feature	Subclause	Value/Comment	Status	Support
CE1	Collision detection to Unique Word Jam transmission delay	16.3.1.3	3.5 BT max	M	Yes [ ]
CE2	Unique Word Jam composition	16.3.1.3	MV0,Unique Word, MV0,Unique Word, MV0,Unique Word, etc....	M	Yes [ ]
CE3	End of data on DO to end of Unique Word Jam transmission delay	16.3.1.3	3.5 BT max	M	Yes [ ]

**16.6.6.11 Receive functions**

Item	Feature	Subclause	Value/Comment	Status	Support
RCV1	Optical to Electrical conversion	16.3.2	As specified in 15.2.2.3	M	Yes [ ]

### 16.6.6.12 Preamble reconstruction and alignment function

Item	Feature	Subclause	Value/Comment	Status	Support
PRA1	Start-up delay (receive MDI to DI)	16.3.2.1	2.5 BT max	M	Yes [ ]
PRA2	Receive delay variability	16.3.2.1	1 BT max for any two packets $\leq 9.6 \mu\text{s}$ apart	M	Yes [ ]
PRA3	Reconstructed preamble composition	16.3.2.1	40 bits of CD1,CD0,CD1,...,CD0 followed by remainder of preamble received on receive MDI	M	Yes [ ]
PRA4	Reconstructed preamble alignment	16.3.2.1	41st bit is CD1	M	Yes [ ]

### 16.6.6.13 Data receive function

Item	Feature	Subclause	Value/Comment	Status	Support
DR1	Receive path (following reconstructed preamble)	16.3.2.2	Receive MDI to DI circuit	M	Yes [ ]
DR2	Steady-state delay (receive MDI to DI)	16.3.2.2	2.5 BT max	M	Yes [ ]

### 16.6.6.14 Signal presence during collision

Item	Feature	Subclause	Value/Comment	Status	Support
SPC1	Signal transmitted on DI during Collision	16.3.2.3	Manchester Fill (CD1,CD0,CD1, etc.)	M	Yes [ ]
SPC2	Transmit valid Manchester during collision	16.3.2.3	For duration of activity on receive MDI	M	Yes [ ]
SPC3	RDARK to end of valid Manchester delay on DI	16.3.2.3	3 BT max	M	Yes [ ]
SPC4	Signal transmitted on DI during invalid data on receive MDI	16.3.2.3	Valid Manchester sequence	M	Yes [ ]

**16.6.6.15 Loopback function**

Item	Feature	Subclause	Value/Comment	Status	Support
LP1	Data Loopback function	16.3.3	DO signals to DI circuit	M	Yes [ ]
LP2	Loopback bit loss (DO to DI)	16.3.3	2 bits max at start of packet	M	Yes [ ]
LP3	Loopback settling time	16.3.3	2nd and following bits shall meet jitter specifications in 15.2.2.2.1	M	Yes [ ]
LP4	Loopback steady-state delay	16.3.3	1 BT max	M	Yes [ ]
LP5	DI circuit driver	16.3.3	See 7.4.1	M	Yes [ ]
LP6	Loopback polarity	16.3.3	No signal inversion from DO to DI	M	Yes [ ]

**16.6.6.16 Collision presence function**

Item	Feature	Subclause	Value/Comment	Status	Support
CP1	CI signaling and timing	16.3.4.1	As specified in 7.3.1.2, and modified by 15.1.3.3 and 15.5.4.1	M	Yes [ ]
CP2	Collision Detection	16.3.4.2	CS0 on CI if DO = active and ORD = active (if IPG $\geq$ OTD to ORD loopback time) or two CRVs detected with no intervening <i>ORD_idle</i>	M	Yes [ ]
CP3	Collision indication delay	16.3.4.2	3.5 BT max after second CRV or 3.5 BT max after presence of DO = active and ORD = active	M	Yes [ ]
CP4	Received Power range for detection of CRV	16.3.4.2	As specified in 15.2.2.1	M	Yes [ ]
CP5	Received Differential Power Range for detection of CRV	16.3.4.2	8.0 dB	M	Yes [ ]
CP6	End of Collision determination	16.3.4.3	CS0 on CI until DO = inactive or ORD = idle; or after waiting 54 BT, 33 BT with no more than one CRV detected	M	Yes [ ]
CP7	End of Collision deassertion delay	16.3.4.3	3 BT max	M	Yes [ ]
CP8	CI circuit with no collision, SQE Test or jabber	16.3.4.3	IDL	M	Yes [ ]

### 16.6.6.17 *signal\_quality\_error* Message (SQE) test function

Item	Feature	Subclause	Value/Comment	Status	Support
STF1	SQE Test induced OTD or DI signal	16.3.5	No extraneous signals permitted	DTE: M	N/A [ ] M: Yes [ ]
STF2	SQE Test timing (after last positive edge on DO) of CS0 on CI	16.3.5	Start 0.6 $\mu$ s to 1.6 $\mu$ s. Duration 5 bits to 15 bits	DTE: M	N/A [ ] M: Yes [ ]

### 16.6.6.18 Jabber function

Item	Feature	Subclause	Value/Comment	Status	Support
JAB1	Jabber function implementation	16.3.6	Self-interrupt of transmit and loopback	M	Yes [ ]
JAB2	Excessive frame timer for jabber detection	16.3.6	20 ms min., 150 ms max.	M	Yes [ ]
JAB3	CI circuit during jabber	16.3.6	CS0 signal	M	Yes [ ]
JAB4	MAU jabber reset delay	16.3.6	0.5 s $\pm$ 0.25 s	M	Yes [ ]
JAB5	State of Loopback function during jabber	16.3.6	Disabled	M	Yes [ ]
JAB6	State of Transmit function during jabber	16.3.6	Disabled	M	Yes [ ]
JAB7	Jabber inhibit	16.3.6	Jabber not activated by the longest permitted output specified in 9.6.5	M	Yes [ ]

### 16.6.6.19 Link Fault Detect function

Item	Feature	Subclause	Value/Comment	Status	Support
LF1	Link Test Timer	16.3.7	10 $\mu$ s $\pm$ 2.5 $\mu$ s	M	Yes [ ]
LF2	Actions during detected failure: Data Transmit function Data Receive function Loopback function	16.3.7	Disabled	M	Yes [ ]
LF3			Disabled	M	Yes [ ]
LF4			Disabled	M	Yes [ ]
LF5	Link heal timer	16.3.7	0.5 s $\pm$ 0.25 s	M	Yes [ ]
LF6	Receive power level for link fault detect	16.3.7	Not sufficient to maintain BER < 10 <sup>-7</sup>	M	Yes [ ]
LF7	Action if receive power level not sufficient to maintain BER < 10 <sup>-7</sup>	16.3.7	CRV = true	M	Yes [ ]
LF8	Link fault reset	16.3.7	Expiration of link_heal_timer followed by optical signal of sufficient power to maintain BER $\leq$ 10 <sup>-7</sup>	M	Yes [ ]



**16.6.6.20 MAU state diagram requirements**

Item	Feature	Subclause	Value/Comment	Status	Support
SD1	Transmit and Receive function state diagram	16.3.9	Meets requirements of Figure 16–2	M	Yes [ ]
SD2	SQE Message Test function state diagram	16.3.9	Meets requirements of Figure 16–3	DTE: M	N/A [ ] M: Yes [ ]
SD3	Link Fault state diagram	16.3.9	Meets requirements of Figure 16–4	M	Yes [ ]
SD4	Jabber function state diagram	16.3.9	Meets requirements of Figure 16–5	M	Yes [ ]
SD5	Collision Detect state diagram	16.3.9	Meets requirements of Figure 16–6	M	Yes [ ]

**16.6.6.21 MAU-to-AUI signal characteristics**

Item	Feature	Subclause	Value/Comment	Status	Support
ASC1	Signaling rate (stated on label)	7.3.2	10 Mb/s	AUI: M	N/A [ ] M: Yes [ ]
ASC2	CS0 signal frequency (on CI)	7.3.1.2	10 MHz $\pm$ 15%	AUI: M	N/A [ ] M: Yes [ ]
ASC3	CS0 signal duty cycle	7.3.1.2	60:40 worst case	AUI: M	N/A [ ] M: Yes [ ]

**16.6.6.22 MAU-to-AUI DI and CI driver characteristics**

Item	Feature	Subclause	Value/Comment	Status	Support
ADC1 ADC2	Differential output voltage: Idle state Start of idle	7.4.1.1	$\leq$ 40 mV after 80 BT. Figure 7–12	AUI: M AUI: M	N/A [ ] M: Yes [ ] N/A [ ] M: Yes [ ]
ADC3	Current into test load while idle	7.4.1.1	4 mA max after 80 BT	AUI: M	N/A [ ] M: Yes [ ]
ADC4	Requirements after idle	7.4.1.2	1st bit to Figure 7–11	AUI: M	N/A [ ] M: Yes [ ]
ADC5	Common-mode output voltage, ac	7.4.1.3	$\leq$ 2.5 V peak for 30 Hz to 40 kHz, $\leq$ 160 mV peak for 40 kHz to 10 MHz, Figure 7–13	AUI: M	N/A [ ] M: Yes [ ]
ADC6	Differential output voltage, open circuit	7.4.1.4	13 V peak max	AUI: M	N/A [ ] M: Yes [ ]
ADC7	Common-mode output voltage, dc	7.4.1.5	$\leq$ 5.5 V, Figure 7–1	AUI: M	N/A [ ] M: Yes [ ]
ADC8	Fault tolerance	7.4.1.6	Figure 7–14	AUI: M	N/A [ ] M: Yes [ ]
ADC9	Fault current	7.4.1.6	$\leq$ 150 mA, any state, Figure 7–14	AUI: M	N/A [ ] M: Yes [ ]

### 16.6.6.23 AUI-to-MAU DO receiver characteristics

Item	Feature	Subclause	Value/Comment	Status	Support
DO1	Unsquelled threshold	7.4.2.1	160 mV max diff	AUI: M	N/A [ ] M: Yes [ ]
DO2	Squelch	15.5.1	Reject signals < ±160 mV differential	AUI: M	N/A [ ] M: Yes [ ]
DO3	High to idle transition	7.4.1.1	Must not cause output	AUI: M	N/A [ ] M: Yes [ ]
DO4	Differential input impedance	7.4.2.2	Real part: $77.83 \Omega \pm 6\%$ , $0 \leq \text{phase angle} \leq \text{real part} * 0.0338$	AUI: M	N/A [ ] M: Yes [ ]
DO5	Common-mode range, ac	7.4.2.3	3 V min for 30 Hz to 40 kHz, 200 mV min for 40 kHz to 10 MHz	AUI: M	N/A [ ] M: Yes [ ]
DO6	Total common-mode range	7.4.2.4	Magnitude of 0 to 5.5 Vac+dc	AUI: M	N/A [ ] M: Yes [ ]
DO7	Common-mode current limit	7.4.2.4	≤ 1 mA	AUI: M	N/A [ ] M: Yes [ ]
DO8	IDL detection	7.3.1.1	≤ 1.6 BT	AUI: M	N/A [ ] M: Yes [ ]
DO9	Requirements after idle	7.4.2.5	Receiver in specification after start-up delay	AUI: M	N/A [ ] M: Yes [ ]
DO10	Receiver fault tolerance	7.4.2.6	Figure 7–16	AUI: M	N/A [ ] M: Yes [ ]
DO11	Input fault current	7.4.2.6	3 mA max for Figure 7–16	AUI: M	N/A [ ] M: Yes [ ]

### 16.6.6.24 MAU-to-AUI circuit termination

Item	Feature	Subclause	Value/Comment	Status	Support
ACT1	Common-mode termination	7.5.2.6	If used, must be to VC	AUI: M	N/A [ ] M: Yes [ ]
ACT2	Pins 1, 4, 8, 11, 14 impedance to VC circuit	7.5.2.8	≤ 5 Ω at 5 MHz	AUI: M	N/A [ ] M: Yes [ ]
ACT3	Pins 1, 4, 8, 11, 14 coupling to VC circuit	7.5.2.8	Capacitive	AUI: M	N/A [ ] M: Yes [ ]

**16.6.6.25 MAU-to-AUI mechanical connections**

Item	Feature	Subclause	Value/Comment	Status	Support
AM1	D-type connector dimensions	7.6.2	IEC 60807-2:1992 15-pole male	AUI: M	N/A [ ] M: Yes [ ]
AM2	Shell plating material	7.6.2	Conductive	AUI: M	N/A [ ] M: Yes [ ]
AM3	Shell multiple contact points	7.6.2	Number not defined (recommended)	AUI: O	N/A [ ] O: Yes [ ] O: No [ ]
AM4	Shell life expectancy	7.6.2	≤ 5 mΩ after 500 matings	AUI: M	N/A [ ] M: Yes [ ]
AM5	Locking posts and mounting	7.6.1	Figures 7–18 and 7–20	AUI: M	N/A [ ] M: Yes [ ]
AM6	Pin connections	7.6.3	Circuit		
AM7	3		Data Out A	AUI: M	N/A [ ] M: Yes [ ]
AM8	10		Data Out B	AUI: M	N/A [ ] M: Yes [ ]
AM9	11		Capacitor to VC	AUI: M	N/A [ ] M: Yes [ ]
AM10	5		Data In A	AUI: M	N/A [ ] M: Yes [ ]
AM11	12		Data In B	AUI: M	N/A [ ] M: Yes [ ]
AM12	4		Capacitor to VC	AUI: M	N/A [ ] M: Yes [ ]
AM13	7		No connection	AUI: M	N/A [ ] M: Yes [ ]
AM14	15		No connection	AUI: M	N/A [ ] M: Yes [ ]
AM15	8		Capacitor to VC	AUI: M	N/A [ ] M: Yes [ ]
AM16	2		Control In A	AUI: M	N/A [ ] M: Yes [ ]
AM17	9		Control In B	AUI: M	N/A [ ] M: Yes [ ]
AM18	1		Capacitor to VC	AUI: M	N/A [ ] M: Yes [ ]
AM19	6		Voltage common	AUI: M	N/A [ ] M: Yes [ ]
AM20	13		Voltage plus	AUI: M	N/A [ ] M: Yes [ ]
AM21	1		Capacitor to VC	AUI: M	N/A [ ] M: Yes [ ]
AM21	Shell		Isolated from all pins	AUI: M	N/A [ ] M: Yes [ ]

**16.6.6.26 MAU reliability**

Item	Feature	Subclause	Value/Comment	Status	Support
MR1	Mean Time Before Failure	15.4	> 10 <sup>7</sup> hours without causing communications failure among other stations	M	Yes [ ]

### 16.6.6.27 Power consumption

Item	Feature	Subclause	Value/Comment	Status	Support
PC1	Power surge limitation	15.5.3	$< 2 \times 10^{-3} \text{ A-s}$	APW: M	N/A [ ] M: Yes [ ]
PC2	Power surge duration	15.5.3	100 ms max	APW: M	N/A [ ] M: Yes [ ]
PC3	Steady-state current drawn	15.5.3	$\leq 0.5 \text{ A}$	APW: M	N/A [ ] M: Yes [ ]
PC4 PC5	Power-up capability: Current-limited sources Voltage-limited sources	15.5.3 7.5.2.5	0.5 A limited. 11.28 to 15.75 V via any AUI cable	APW: M APW: M	N/A [ ] M: Yes [ ] N/A [ ] M: Yes [ ]
PC6	Labeling	15.5.3	As in 15.5.315.5.3	APW: M	N/A [ ] M: Yes [ ]
PC7	Power cycle behavior	15.5.3	No extraneous signals on MDI, DI, or CI	AUI: M	
PC8	Low VP behavior	7.5.2.5	No disruption of media	APW: M	N/A [ ] M: Yes [ ]
PC9	Power sourced on pin 13 of AUI	15.5.3	None if separate power source is implemented	SPW: X	N/A [ ] X: Yes [ ]
PC10	Optional power source iso- lation	15.5.3	If implemented, shall with- stand one of 15.3.4 tests	SPW: M	N/A [ ] M: Yes [ ]

### 16.6.6.28 PLS–PMA requirements

Item	Feature	Subclause	Value/Comment	Status	Support
PMA1	Messages between PLS in DTE or Repeater and PMA	15.5.4	As in 7.2.1	M	Yes [ ]

### 16.6.6.29 *signal\_quality\_error* message (SQE)

Item	Feature	Subclause	Value/Comment	Status	Support
SQE1	Local MAU Transmitting and no Collision or Fault Detected	15.5.4.2.1	<i>MAU_available</i> sent on CI	M	Yes [ ]
SQE2	Whenever a Collision exists as described in 16.3.4	15.5.4.2.1	SQE sent	M	Yes [ ]
SQE3	SQE Test as described in 16.3.5	15.5.4.2.1	SQE sent	DTE: M RPT: X	N/A [ ] M: Yes [ ] N/A [ ] X: Yes [ ]
SQE4	Jabber Condition exists as described in 16.3.6	15.5.4.2.1	SQE sent	M	Yes [ ]
SQE5	Message sent in the absence of SQE	15.5.4.2.1	<i>MAU_available</i> message	M	Yes [ ]

**16.6.6.30 Environmental requirements**

Item	Feature	Subclause	Value/Comment	Status	Support
E1	Ambient plane wave field in which MAU meets specification	15.6.2	2 V/m from 10 kHz to 30 MHz. 5 V/m from 30 MHz to 1 GHz	M	Yes [ ]
E2	Electromagnetic emissions and susceptibility	15.6.2	Comply with local and/or national requirements. If none exist, comply with CISPR 22: 1993.	M	Yes [ ]

**16.6.6.31 MAU labeling**

Item	Feature	Subclause	Value/Comment	Status	Support
LBL1	MAU Type	15.7	10BASE-FP	O	Yes [ ] No [ ]
LBL2	Data Rate	15.7	10 Mb/s	O	Yes [ ] No [ ]
LBL3	Power Level	15.7	Maximum current drain	O	Yes [ ] No [ ]
LBL4	Safety Warnings	15.7	Any applicable	O	Yes [ ] No [ ]
LBL5	Port Labeling	15.7	Input and output	O	Yes [ ] No [ ]
LBL6	Manufacturer ID and MAU ID	15.7	12-bit Manufacturer ID and 20-bit MAU ID in separate fields	O	Yes [ ] No [ ]

**16.6.7 PICS proforma tables for 10BASE-FP stars****16.6.7.1 Star basic functions**

Item	Feature	Subclause	Value/Comment	Status	Support
SB1	Optical power division	16.5.1.2	Divide optical power from an input among all outputs (as described in 16.5.2.2)	M	Yes [ ]
SB2	Configuration of 10BASE-FP Stars and MAUs	16.5.1.3	MAU OTD to star input port. MAU ORD to star output port.	M	Yes [ ]
SB3	MTBF without causing communications failure among attached stations	16.5.1.4	10 <sup>7</sup> hours	M	Yes [ ]

### 16.6.7.2 Star optical characteristics

Item	Feature	Subclause	Value/Comment	Status	Support
SO1	Insertion loss	16.5.2.1	16 dB min 20 dB max	M	Yes [ ]
SO2	Single output port uniformity	16.5.2.2	2.5 dB max	M	Yes [ ]
SO3	Directivity	16.5.2.3	35 dB min	M	Yes [ ]
SO4	Connector socket	15.3.2	BFOC/2.5—see IEC 60874-10:1992	M	Yes [ ]
SO5	Optical connector loss	15.3.2.1	< 1.0 dB	O	Yes [ ] No [ ]
SO6	Optical connector return loss	15.3.2.2	> 25 dB	M	Yes [ ]

### 16.6.7.3 Star environmental requirements

Item	Feature	Subclause	Value/Comment	Status	Support
SE1	Ambient plane wave field in which star meets specification	15.6.2	2 V/m from 10 kHz to 30 MHz. 5 V/m from 30 MHz to 1 GHz	M	Yes [ ]
SE2	Electromagnetic emissions and susceptibility	15.6.2	Comply with local and/or national requirements. If none exist, comply with CISPR 22: 1993.	M	Yes [ ]

### 16.6.7.4 10BASE-FP star labeling

Item	Feature	Subclause	Value/Comment	Status	Support
SL1	Device type	15.7.1	10BASE-FP Star	O	Yes [ ] No [ ]
SL2	Port labeling	15.7.1	Input and output	O	Yes [ ] No [ ]

## 17. Fiber optic medium attachment unit, type 10BASE-FB

### 17.1 Scope

#### 17.1.1 Overview

This clause, along with Clause 15, defines the functional, electrical, optical, and mechanical characteristics of an optimized fiber optic link for interconnecting repeaters. The relationship of this specification to the entire ISO/IEC 8802-3 CSMA/CD International Standard is shown in Figure 15-1b). This fiber optic link may be used to interconnect repeaters in star topologies and consists of a new PMA specific to the repeater (including a fiber optic MDI specified in 15.2), and the fiber optic medium specified in 15.3. This clause defines a MAU that extends the link distances beyond MAUs specified in 9.9 and significantly increases the number of allowable repeaters in series. While this clause defines a MAU, the AUI shall exist only as a logical service interface.

##### 17.1.1.1 Medium attachment unit

The 10BASE-FB MAU has the following general characteristics:

- a) It enables coupling of the Physical Layer Signaling (PLS) messages to the baseband fiber optic link defined in Clause 15.
- b) It supports message traffic at a data rate of 10 Mb/s.
- c) It provides for operating over 0 to at least 2000 m of fiber optic cable specified in 15.3.
- d) It transmits both data and idle signals synchronously with the bit clock and receives data without resynchronizing on each packet.
- e) It connects a repeater to a fiber optic backbone link segment.
- f) It provides point-to-point signaling of status via synchronous signaling as defined in 17.2.1.
- g) It transmits synchronous signals as defined in 17.2.1.
- h) It supports network configurations using the CSMA/CD access method defined in IEEE 802.3 with baseband signaling.
- i) It supports a point-to-point interconnection between repeaters, and when used with repeaters having multiple ports, supports a star wiring topology.

##### 17.1.1.2 Relationship to repeater

A close relationship exists between Clause 17 and Clause 9. Clause 17 specifies the PMA logical functions residing in the MAU that exist as an integrated MAU in the repeater. A logical interface using messages associated with the AUI is provided as the interface with the repeater. In addition, the Data Loopback function is provided to ensure proper operation of the Partition function defined in 9.6.6.

##### 17.1.1.3 Remote diagnostic messages

The MAU implements remote status signaling during fault conditions. The MAU transmits status messages defined in 17.2.2 and detects the messages described in 17.2.3.

### 17.1.2 Relationship to AUI

There is no physical implementation of AUI associated with the MAU. Implementation of an AUI, while possible, is beyond the scope of the International Standard. Messages associated with the AUI, however, are used throughout this document as a means to interface with the repeater. Thus, the sole purpose of the use of the messages associated with the AUI is as a service interface. The PMA uses the variables In, Out, and Col and their associated messages to communicate with a port in the repeater.

## 17.2 PMA interface messages

The messages between a port in the repeater and the PMA in the MAU shall comply with the PMA interface messages in 17.2.1 and 15.5.4. The messages between the PMAs over the MDI are summarized below.

### 17.2.1 PMA-to-MDI interface signal encodings

The following signals are used by the interface messages between the PMA and the MDI:

**Manchester-Encoded Data One, CD.** A clocked bit symbol in which the first half is LO and the second half is HI.

**Manchester-Encoded Data Zero, CD0.** A clocked bit symbol in which the first half is HI and the second half is LO.

**Manchester Code Violation One, MV1.** A clocked bit symbol in which the symbol is HI for the bit duration.

**Manchester Code Violation Zero, MV0.** A clocked bit symbol in which the symbol is LO for the bit duration.

**Synchronous Idle, SIDL.** Control symbol series coded as the repeating sequence of MV1, MV1, MV0, MV0, starting with the first MV1, resulting in 2.5 MHz signal.

**Remote Fault, RF.** Control symbol series coded as the repeating sequence of MV1, MV1, MV1, MV0, MV0, MV0, starting with the first MV1, resulting in 1.667 MHz signal.

### 17.2.2 PMA-to-MDI OTD messages

The signals SIDL and RF shall be made up of sequences of the symbols MV1 and MV0 listed in the table and illustrated in Figure 17–1. All signals shall be transmitted synchronized to the local bit clock. SIDL and RF appear only between PMAs. The following messages can be sent by the MAU PMA to the MDI OTD (Optical Transmit Data) circuit:

Message	Circuit	Signal	Meaning
OTD_output	OTD	CD1, CD0	Output information
OTD_sync_idle	OTD	SIDL (MV1, MV1, MV0, MV0)	Synchronous idle
OTD_remote_fault	OTD	RF (MV1, MV1, MV1, MV0, MV0, MV0)	Jabber, Low Light, Invalid Data, or Lock Lost detected

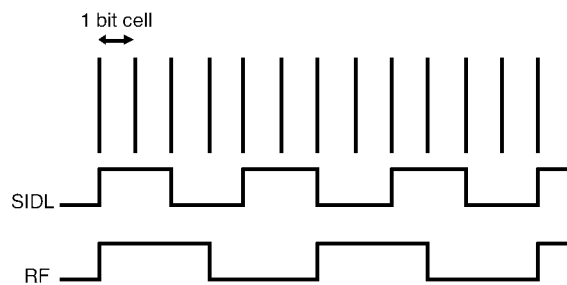


Figure 17–1—MDI status signaling messages



### 17.2.2.1 OTD\_output

The PMA sublayer sends the *OTD\_output* message to the OTD circuit when the repeater outputs a bit of data to the MDI's OTD circuit and the MDI's OTD circuit and the PMA is not sending the *OTD\_remote\_fault* message. The physical realization of the *OTD\_output* message is a CD0 or CD1 signal sent by the PMA.

### 17.2.2.2 OTD\_sync\_idle

The PMA sublayer sends the *OTD\_sync\_idle* message to the OTD circuit when the repeater sends idle and the PMA is not sending *OTD\_remote\_fault* message. The physical realization of the *OTD\_sync\_idle* message is a repeating sequence of the SIDL signal sent by the PMA.

### 17.2.2.3 OTD\_remote\_fault

The PMA sublayer sends *OTD\_remote\_fault* message to the OTD circuit when receive jabber is detected, low light has been detected, invalid data has been detected, or continuous clock recovery condition per 17.3.8 is not met ("lock\_lost" = true). The physical realization of the *OTD\_remote\_fault* message is a repeating sequence of the RF signal sent by the PMA. The *OTD\_remote\_fault* message may be sent when local faults other than the receive jabber, low light or invalid data are present on the ORD circuit. However, the partition condition of the repeater port shall not cause *OTD\_remote\_fault* to be sent.

## 17.2.3 MDI ORD-to-PMA messages

### 17.2.3.1 Status decoding

The following messages shall be received by the MAU PMA from the MDI ORD (Optical Receive Data) circuit.

### 17.2.3.2 ORD\_input

When the PMA sublayer receives the *ORD\_input* message on its ORD circuit, it detects a bit of data. The physical realization of the *ORD\_input* message is the CD0 or CD1 signal.

### 17.2.3.3 ORD\_sync\_idle

When the PMA sublayer receives the *ORD\_sync\_idle* message on its ORD circuit, it detects idle. The physical realization of the *ORD\_sync\_idle* message is the SIDL signal.

### 17.2.3.4 ORD\_remote\_fault

When the PMA sublayer receives the *ORD\_remote\_fault* message on its ORD circuit, it detects remote fault. The physical realization of the *ORD\_remote\_fault* message is the RF signal.

### 17.2.3.5 ORD\_invalid\_data

When the PMA sublayer receives signals other than CD0, CD1, SIDL, or RF while low light is not detected, or input signals that do not meet the requirements in 17.2.4 and 17.3.8, it detects invalid data. The physical realization of the *ORD\_invalid\_data* message is a signal not meeting the above allowed set.

Message	Circuit	Signal	Meaning
ORD_input	ORD	CD1, CD0	Input Information
ORD_sync_idle	ORD	SIDL (MV1, MV1, MV0, MV0)	Synchronous Idle
ORD_remote_fault	ORD	RF (MV1, MV1, MV1, MV0, MV0, MV0)	Jabber, Low Light, Invalid Data, or LockLost=true detected by the far-end MAU
ORD_invalid_data	ORD	Any signal other than CD0, CD1, SIDL or RF	Undefined or asynchronous signal

### 17.2.4 Transitions between signals

The SIDL to data (CD0 or CD1) transition shall occur at any bit cell boundary. SIDL shall begin with its first MV1 immediately following the last bit cell of a packet. When a fault is detected during data transmission, the RF signal shall be transmitted immediately following the next bit cell boundary, starting with the first MV1. When a signal that contains alternating MV0 and MV1, starting with a MV0, is detected during a data reception, it shall be interpreted as alternating CD0 and CD1 as long as the sequence persists. When a fault is detected during idle, the SIDL sequence shall be completed before sending RF. Other than defined above, any transition from one status signal to another status signal shall begin only after the previous signal has been sent in its entirety.

### 17.2.5 Signaling rate

The signaling rate shall conform to 7.3.2.

## 17.3 MAU functional specifications

The MAU provides the means by which repeaters can be connected for backbone applications by the use of synchronous signaling. In addition, the MAU provides the means by which status on one end of the link may be signaled to the other end to provide media diagnostics.

### 17.3.1 Transmit function requirements

The Transmit function shall transmit the output message received from the repeater unit onto the MDI. The Transmit function has three purposes:

- a) To convert the electrical signals to optical signals.
- b) To generate the SIDL signal when receiving the *output\_idle* message from the repeater.
- c) To generate the RF signal.

The levels and timing of the optical signal shall be as specified in 15.2.1, and any transition from one signal to another shall meet the requirements in 17.2.4.

#### 17.3.1.1 Data transmit

The Transmit function shall receive the output messages from the repeater unit and send them onto the MDI OTD circuit. When a packet is received at this interface, no bit of information shall be received from the repeater and not transmitted to the MDI. In addition, only the bits of information received from the repeater shall be transmitted to the MDI. The start-up and steady-state delay between output message and

transmission on the MDI shall each be no more than 2 BT. If a fault is detected during data transmission, data transmission shall cease and the RF signal shall be transmitted as specified in 17.2.4 and 17.3.1.3.

### 17.3.1.2 Synchronous idle

Whenever the repeater unit sends the *idle* message, SIDL signal shall be sent on the OTD circuit of the MDI, when the PMA is not sending the *OTD\_remote\_fault* message.

### 17.3.1.3 Fault signaling

Upon detecting receive jabber as specified in 17.3.6, or low light as specified in 17.3.7, or unqualified input signal as specified in 17.3.8, the Transmit function shall output RF signal on the OTD circuit of the MDI.

## 17.3.2 Receive function requirements

The Receive function shall receive optical signals from the ORD circuit of the MDI and send *input* or *idle* messages to the repeater unit. The Receive function has two purposes:

- a) To convert optical signals to electrical signals.
- b) To detect and interpret CD0, CD1, SIDL, and RF.

The optical to electrical conversion shall be as specified in 15.2.2.3.

### 17.3.2.1 Data receive

The Receive function shall receive the CD0 or CD1 signals from the ORD circuit of the MDI and send *input* messages to the repeater unit. When a packet is received, all bits of information shall be received from the ORD circuit and sent to the repeater unit. In addition, only the bits of information received from the ORD circuit shall be sent to the repeater unit. Any transition of one signal to another not meeting the requirements in 17.2.4 shall be detected as *ORD\_invalid\_data* message. When *ORD\_invalid\_data* message is received, data transmission shall be prevented. The start-up and steady-state delay between reception on MDI to *input* message shall be no more than 2 BT.

### 17.3.2.2 Remote status message handling

The Receive function shall recognize the signals SIDL or RF at the MDI and send the *input\_idle* message to the repeater unit. The reception of the RF signal at the MDI shall prevent data transmissions.

## 17.3.3 Collision function requirements

### 17.3.3.1 Collision detection

The MAU shall detect as a collision the simultaneous occurrence of *ORD\_input* message on the ORD circuit and the *output* message from the repeater. When a collision has occurred, the *signal\_quality\_error* message shall be sent to the repeater within 3.5 BT.

### 17.3.3.2 End of collision

The MAU shall detect as the end of collision either the *output\_idle* message or messages other than *ORD\_input* received from the ORD circuit. When the end of a collision occurs, the *mau\_available* message shall be sent to the repeater within 5 BT and the *input\_idle* message shall be sent to the repeater within 5 BT.

### 17.3.4 Loopback function requirements

The Loopback function is defined to provide the same service interface as other MAUs between the PMD and the repeater. Since this MAU does not have a physical AUI, this function is logically present but not necessarily physically implemented.

When the MAU is transmitting on the OTD circuit and is not receiving *ORD\_input* messages on the ORD circuit, the MAU shall transmit either *output* messages as *input* messages or *output\_idle* messages as *input\_idle* messages. The steady-state propagation delay of this message transfer shall not exceed 2 BT.

### 17.3.5 Fault-handling function requirements

There are two types of faults that shall be detected: local and remote. The local faults are detection of low light, receive jabber, and invalid data conditions. The remote status signals consist of receptions of normal idle (indicated by the signal SIDL), and remote faults (indicated by the signal RF). Table 17–1 defines the signals that shall be sent onto the media at the port’s MDI during fault conditions.

**Table 17–1—MDI fault conditions and their states**

Fault types	Signal at OTD MDI
Low Light detected	RF
Receive Jabber detected	RF
Invalid Data detected	RF
Receive RF	SIDL

During reception of RF, SIDL shall be transmitted at the MDI, unless there is a local fault.

### 17.3.6 Jabber function requirements

A MAU shall contain a self-interrupt capability, as described in Figure 17–3, to prevent an illegally long reception of data from reaching the Data-Handling function of the repeater. The MAU shall provide a window “rcv\_max” during which the *input* messages may be sent to the repeater unit. The value of “rcv\_max” shall be between 8 ms and 12 ms. If a reception exceeds this duration, the jabber condition shall be detected.

Upon detection of the jabber condition, the MAU shall perform the following:

- a) Inhibit sending further *input* messages to the repeater unit,
- b) Disable the *OTD\_sync\_idle* message (17.2.2.2) to the MDI, and
- c) Send the *OTD\_remote\_fault* message (17.2.2.3) to the MDI.

The MAU shall reset the Jabber function and reassert *OTD\_sync\_idle* message when one of the following conditions is met:

- On power-up reset, or
- After a continuous time “rcv\_unjab” of not detecting jabber on the ORD circuit of the MAU (see Figure 17–3).

The value of “rcv\_unjab” shall be 0.5 s ± 0.25 s.

### 17.3.7 Low light level detection function requirements

The MAU shall have the capability to interrupt a port's reception at the MDI ORD circuit when reliable reception can no longer be assured at that port based on the incoming optical power level.

The MAU shall have a low light level detection capability as defined in Figure 17–2. It shall interrupt reception of any signals from the ORD circuit of the MDI when reliable detection can no longer be assured. This error condition shall not be detected if the average receive optical power level at the MDI exceeds  $-32.5$  dBm in the frequency band between 0.5 MHz to 25 MHz. It shall also not be detected if the low light condition remains for less than 30 BT. It shall be detected before the average receive optical power level at the MDI has fallen to a level that is lower than the average receive optical power level that corresponds to a BER of one part in  $10^{10}$  for the MAU for a duration of 2000 BT. The low light level detected condition shall cease to exist when the received optical power level exceeds the power level required to maintain a BER of one part in  $10^{10}$  and the requirements in 17.3.8 are met.

On detection of the low light level detection condition at its MDI, the MAU shall perform the following:

- a) Inhibit sending further input messages to the repeater unit,
- b) Inhibit the Data Transmit function,
- c) Disable the *OTD\_sync\_idle* message (17.2.2.2) to the MDI, and
- d) Send the *OTD\_remote\_fault* message (17.2.2.3) to the MDI.

Once the low light condition continuously ceases to exist at the port for a time “low\_light\_heal” of  $0.5 \text{ s} \pm 0.25 \text{ s}$ , the MAU shall reset the Low Light function.

### 17.3.8 Synchronous qualification function requirements

The MAU shall have the capability in Figure 17–2 to interrupt reception at the MDI when reliable reception can no longer be assured based on the loss of clock recovery. The synchronous signaling condition shall be detected at a port if SIDL or RF is detected for the entire duration of the time “validation” of successful and continuous clock recovery. The value of time “validation” shall be between 64 BT and 128 BT. The clock recovery shall tolerate the jitter specified in 15.2.2.2 at the MDI and recover clocks with proper frequency and tolerances. The variable “lock\_lost” shall not take the value “true” when the input meets the requirements of 15.2.2. The variable “lock\_lost” shall take the value true within  $20 \mu\text{s}$  after the input frequency on the ORD circuit is less than or equal to 1.55 MHz or greater than or equal to 15.5 MHz.

On qualifying the synchronous signaling condition for signals received on the ORD circuit of the MAU, Data Transmit and Data Receive for that port shall be enabled. On loss of synchronous signaling qualification for the MAU, Data Transmit and Data Receive for that port shall be disabled, and the PMA sublayer shall send *OTD\_remote\_fault* on the MDI.

### 17.3.9 Interface message time references

Delay and bit loss specification are measured from the occurrence of messages at the MDIs. The following describes the point where each message starts:

Message	Reference
OTD_output	leading bit cell boundary of first CD1 or CD0
OTD_sync_idle	last positive-going transition prior to start of SIDL
OTD_remote_fault	last positive-going transition prior to start of RF
ORD_input	leading bit cell boundary of first CD1 or CD0
ORD_sync_idle	last positive-going transition prior to start of SIDL
ORD_remote_fault	last positive-going transition prior to start of RF

### 17.3.10 MAU state diagrams

The state diagrams of Figure 17–2, Figure 17–3, and Figure 17–4<sup>36</sup> depict the full set of allowed MAU state functions relative to the circuits of the MDI and AUI Service Interface. The notation used in the state diagrams follows the conventions in 1.2.1. The variables, counters, and timers used in the state diagrams are defined in the following subclauses.

#### 17.3.10.1 MAU state diagram variables

Variables are used in the state diagrams to indicate the status of the MAU's inputs and outputs, to control its operation, and to pass state information between functions.

In the variable definitions, the name of the variables is followed by a brief description of the variable and a list of values the variable may take. For those variables that are state diagram outputs, one value will be identified as the default. The variable has the default value when no active state contains a term assigning a different value.

The variables used in the state diagrams are as follows:

##### begin

The interprocess flag controlling state diagram initialization values.

Values: false (default).  
true.

##### OTD

Controls the signal sent by the MAU's PMA to the OTD circuit.

Values: idle; the MAU sends *OTD\_sync\_idle*, SIDL (default).  
output; the MAU sends *OTD\_output*; CD0 or CD1, based on the *output* message from the repeater unit.  
remote\_fault; the MAU sends *OTD\_remote\_fault*, RF.

##### ORD

Status of the signal sent by the MAU's ORD circuit to the PMA.

Values: idle; the MAU receives *ORD\_sync\_idle*, SIDL.  
input; the MAU receives *ORD\_input*; CD0, CD1, or MV0,MV1 signal sequence meeting 17.2.4.  
remote\_fault; the MAU receives *ORD\_remote\_fault*, RF.  
invalid\_data; the MAU receives *ORD\_invalid\_data*, all signals not meeting 17.2.4. and 17.3.8.

##### OUT

Status of the messages sent by the repeater to the PMA.

Values: idle; receives *output\_idle* message from the repeater unit.  
output; receives *output* message from the repeater unit.

##### IN

Controls the signal sent by the MAUs PMA to the repeater.

Values: idle; the MAU sends the *input\_idle* message to the repeater (default).  
input; the MAU sends the *input* message to the repeater.  
OUT; the MAU sends messages from the repeater back to the repeater.

<sup>36</sup>The MAU state diagrams, Figures 17–2 through 17–4, follow 17.3.10.2.

**COL**

Controls the signal sent by the MAUs PMA to the repeater.

Values: `mau_available`; the MAU sends the *mau\_available* message to the repeater (default).  
`signal_quality_error`; The MAU sends the *signal\_quality\_error* message to the repeater.

**low\_light\_detected**

Controls the paths of the signals received from the ORD circuit.

Values: `true`; low light condition is being detected.  
`false`; low light condition is not being detected (default).

**rcv\_jab\_detected**

Also controls the path of the signals received from the ORD circuit.

Values: `false`; receive jabber condition is not being detected (default).  
`true`; receive jabber condition is being detected.

**low\_light\_level**

Status of the optical signal level received on the ORD circuit.

Values: `true`; insufficient light is being received for reliable reception (see 17.3.7).  
`false`; sufficient light is being received for reliable reception.

**lock\_lost**

Status of the Synchronous Qualification function of the ORD circuit.

Values: `true`; clock has not been recovered.  
`false`; clock has been recovered.

**link\_valid**

Interprocess flag indicating that the link is valid.

Values: `false`; link is determined to be invalid (default).  
`true`; link is determined to be valid.

**17.3.10.2 MAU state diagram timers**

All timers operate in the same fashion. A timer is reset and starts counting upon entering a state where “start x\_timer” is asserted. When the timer has expired, `x_timer_done` is asserted and remains asserted until the timer is reset. At all other times, `x_timer_not_done` is asserted. The timer is reset and restarted even if the entered state is the same as the exited state.

The timers used in the MAU state diagrams are defined as follows:

**validation\_timer.** Timer for synchronous link detection (17.3.8).

**rcv\_max\_timer.** Timer for excessively long reception (17.3.6).

**rcv\_unjab\_timer.** Timer for the length of time the ORD circuit must have no excessively long activity to exit the jabber state (17.3.6).

**low\_light\_heal\_timer.** Timer for low light condition cessation (17.3.7).

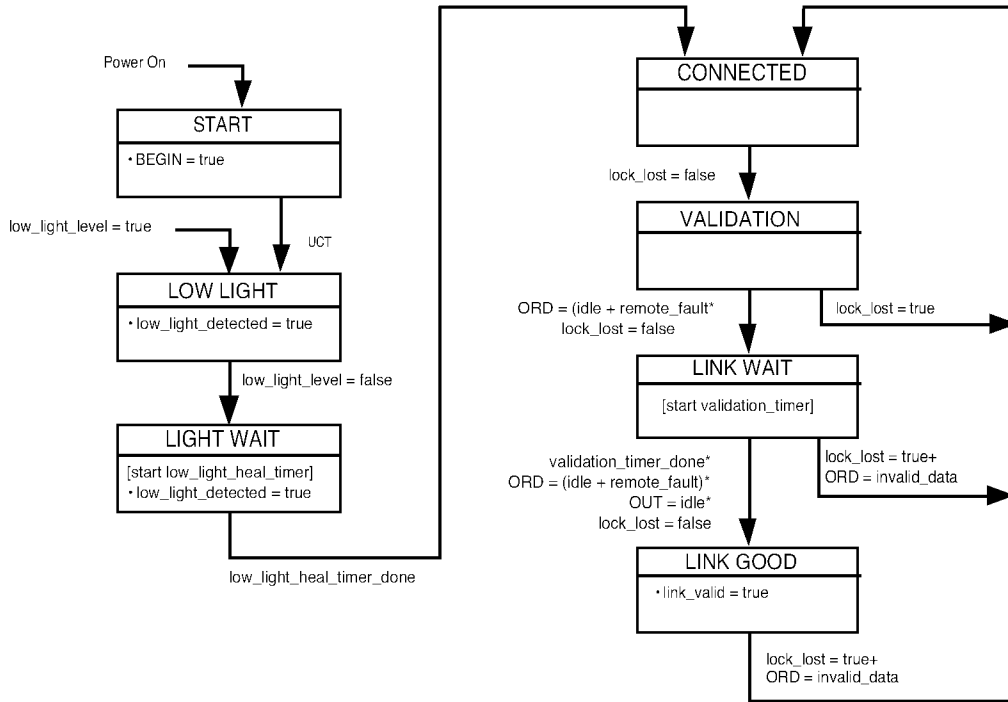


Figure 17-2—Synchronous qualification state diagram

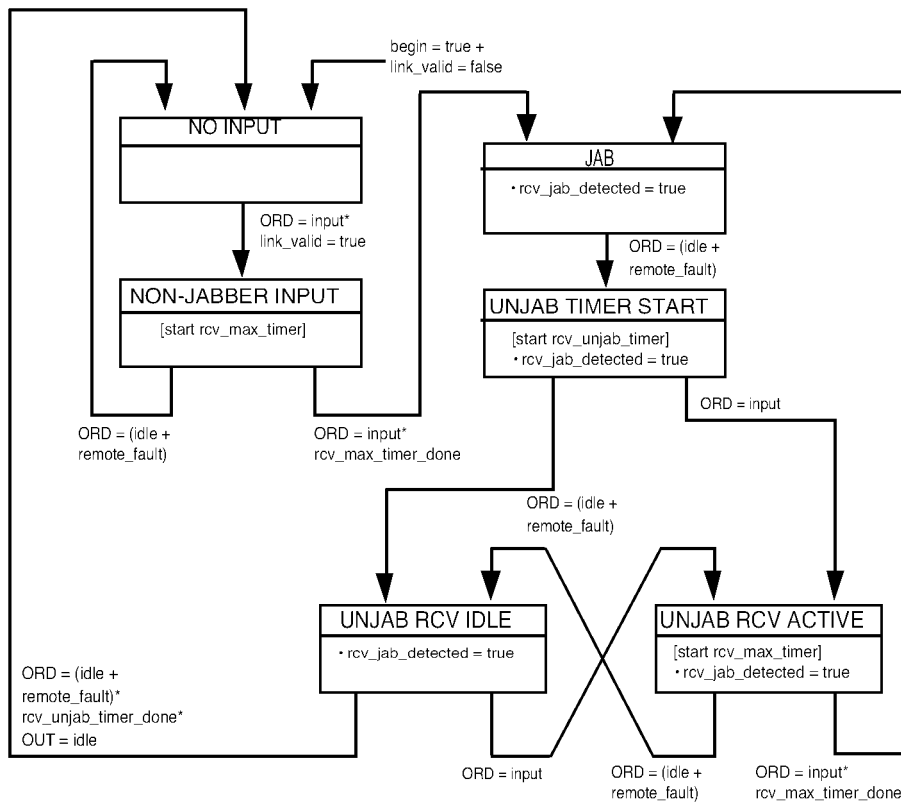
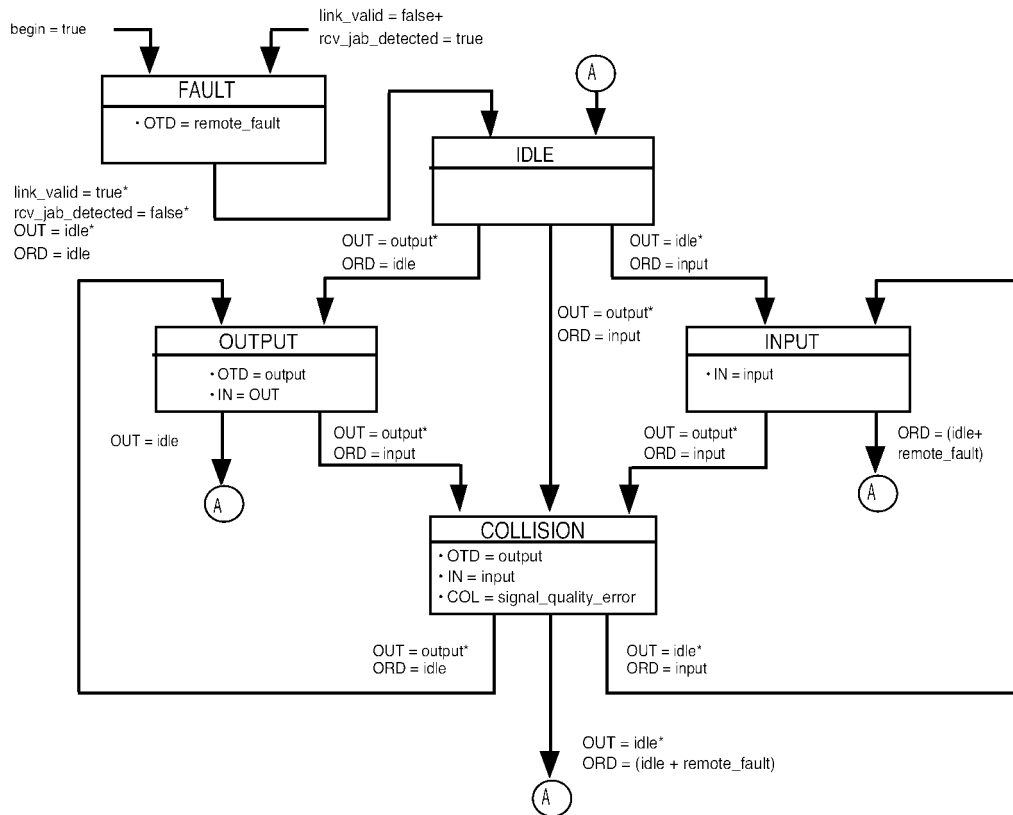


Figure 17-3—Receive jabber state diagram





**Figure 17–4—MAU transmit, receive, loopback, and collision presence functions state diagram**

## 17.4 Timing summary

Table 17–2 summarizes the timing requirements for the 10BASE-FB fiber link. This table is a summary; for complete descriptions of the timing requirements, refer to the referenced subclauses. All times are in bit times.

**Table 17–2—Maximum timing parameters**

Symbol	Function	Bit loss	Invalid bits	Steady-state prop. delay	Start-up delay		Specified in
					Max	Var.	
M1	<i>ORD_input</i> to <i>input</i> to PMA	0.0	0.0	2.0	2.0	2.0	17.3.2.1
M2	<i>output</i> on PMA to <i>OTD_output</i>	0.0	0.0	2.0	2.0	2.0	17.3.1.1
M3	<i>ORD_input</i> * <i>output</i> to <i>signal_quality_error</i>				3.5		17.3.3.1
M4	<i>ORD_sync_idle</i> + <i>output_idle</i> (end of collision) to <i>mau_available</i>				5.0		17.3.3.2
M5	<i>ORD_input</i> * <i>output</i> to <i>input</i> to PMA from circuit ORD				5.0		17.3.3.2
M6	<i>ORD_sync_idle</i> * <i>output</i> to <i>input</i> to PMA from PMA output circuit				5.0		17.3.3.2
M9	<i>output</i> on PMA to <i>input</i> to PMA	0.0	0.0	2.0			17.3.4
F1	Fiber Optic Cable Propagation (2000 m)	0	0	100	100		15.3.1.3

## 17.5 Protocol implementation conformance statement (PICS) proforma for Clause 17, Fiber optic medium attachment unit, type 10BASE-FB<sup>37</sup>

### 17.5.1 Introduction

The supplier of a protocol implementation that is claimed to conform to Clause 17, Fiber optic medium attachment unit, type 10BASE-FB, shall complete the following protocol implementation conformance statement (PICS) proforma.

A completed PICS proforma is the PICS for the implementation in question. The PICS is a statement of which capabilities and options of the protocol have been implemented. The PICS can be used for a variety of purposes by various parties, including the following:

- As a checklist by the protocol implementor, to reduce the risk of failure to conform to the International Standard through oversight;
- As a detailed indication of the capabilities of the implementation, stated relative to the common basis for understanding provided by the standard PICS proforma, by the supplier and acquirer, or potential acquirer, of the implementation;
- As a basis for initially checking the possibility of interworking with another implementation by the user, or potential user, of the implementation (note that, while interworking can never be guaranteed, failure to interwork can often be predicted from incompatible PICSs);
- As the basis for selecting appropriate tests against which to assess the claim for conformance of the implementation, by a protocol tester.

### 17.5.2 Abbreviations and special symbols

#### 17.5.2.1 Status symbols

The following symbols are used in the PICS proforma:

M	mandatory field/function
O	optional field/function
O.<n>	optional field/function, but at least one of the group of options labeled by the same numeral <n> is required
O/<n>	optional field/function, but one and only one of the group of options labeled by the same numeral <n> is required
X	prohibited field/function
<item>:	simple-predicate condition, dependent on the support marked for <item>

#### 17.5.2.1.1 Abbreviations

N/A	not applicable
-----	----------------

### 17.5.3 Instructions for completing the PICS proforma

#### 17.5.3.1 General structure of the PICS proforma

The first part of the PICS proforma, Implementation Identification and Protocol Summary, is to be completed as indicated with the information necessary to identify fully both the supplier and the implementation.

<sup>37</sup>Copyright release for PICS proformas: Users of this standard may freely reproduce the PICS proforma in this subclause so that it can be used for its intended purpose and may further publish the completed PICS.

The main part of the PICS proforma is a fixed-format questionnaire divided into subclauses, each containing a group of items. Answers to the questionnaire items are to be provided in the right-most column, either by simply marking an answer to indicate a restricted choice (usually Yes, No, or Not Applicable), or by entering a value or a set or range of values. (Note that there are some items where two or more choices from a set of possible answers can apply; all relevant choices are to be marked.)

Each item is identified by an item reference in the first column; the second column contains the question to be answered; the third column contains the reference or references to the material that specifies the item in the main body of the International Standard; the fourth column contains values and/or comments pertaining to the question to be answered. The remaining columns record the status of the item—whether the support is mandatory, optional, or conditional—and provide the space for the answers; see also 17.5.3.4 below.

The supplier may also provide, or be required to provide, further information, categorized as either Additional Information or Exception Information. When present, each kind of further information is to be provided in a further subclause of items labeled A<*i*> or X<*i*>, respectively, for cross-referencing purposes, where <*i*> is any unambiguous identification for the item (e.g., simply a numeral); there are no other restrictions on its format or presentation.

A completed PICS proforma, including any Additional Information and Exception Information, is the protocol implementation conformance statement for the implementation in question.

Note that where an implementation is capable of being configured in more than one way, according to the items listed under 17.5.5, Major Capabilities/Options, a single PICS may be able to describe all such configurations. However, the supplier has the choice of providing more than one PICS, each covering some subset of the implementation's configuration capabilities, if that would make presentation of the information easier and clearer.

### **17.5.3.2 Additional information**

Items of Additional Information allow a supplier to provide further information intended to assist the interpretation of the PICS. It is not intended or expected that a large quantity will be supplied, and the PICS can be considered complete without any such information. Examples might be an outline of the ways in which a (single) implementation can be set up to operate in a variety of environments and configurations; or a brief rationale, based perhaps upon specific application needs, for the exclusion of features which, although optional, are nonetheless commonly present in implementations of the 10BASE-FB protocol.

References to items of Additional Information may be entered next to any answer in the questionnaire, and may be included in items of Exception Information.

### **17.5.3.3 Exception information**

It may occasionally happen that a supplier will wish to answer an item with mandatory or prohibited status (after any conditions have been applied) in a way that conflicts with the indicated requirement. No pre-printed answer will be found in the Support column for this; instead, the supplier is required to write into the Support column an X<*i*> reference to an item of Exception Information, and to provide the appropriate rationale in the Exception item itself.

An implementation for which an Exception item is required in this way does not conform to this International Standard.

Note that a possible reason for the situation described above is that a defect in the International Standard has been reported, a correction for which is expected to change the requirement not met by the implementation.

### 17.5.3.4 Conditional items

The PICS proforma contains a number of conditional items. These are items for which both the applicability of the item itself, and its status if it does apply—mandatory, optional, or prohibited—are dependent upon whether or not certain other items are supported.

Individual conditional items are indicated by a conditional symbol of the form “<item>:<s>” in the Status column, where “<item>” is an item reference that appears in the first column of the table for some other item, and “<s>” is a status symbol, M, O, or X.

If the item referred to by the conditional symbol is marked as supported, the conditional item is applicable, and its status is given by “<s>”; the support column is to be completed in the usual way. Otherwise, the conditional item is not relevant and the Not Applicable (N/A) answer is to be marked.

Each item whose reference is used in a conditional symbol is indicated by an asterisk in the Item column.

### 17.5.4 Identification

#### 17.5.4.1 Implementation identification

Supplier	
Contact point for queries about the PICS	
Implementation Name(s) and Version(s)	
Other information necessary for full identification—e.g., name(s) and version(s) for machines and/or operating systems; System Name(s)	
NOTE 1—Only the first three items are required for all implementations; other information may be completed as appropriate in meeting the requirements for the identification. NOTE 2—The terms Name and Version should be interpreted appropriately to correspond with a supplier’s terminology (e.g., Type, Series, Model).	

#### 17.5.4.2 Protocol summary

Identification of protocol specification	IEEE Std 802.3-2008, Clause 17, Fiber optic medium attachment unit, type 10BASE-FB
Identification of amendments and corrigenda to this PICS proforma which have been completed as part of this PICS	
Have any Exception items been required? No [ ] Yes [ ] (See 17.5.3.3; The answer Yes means that the implementation does not conform to IEEE Std 802.3-2008.)	

Date of Statement	
-------------------	--

### 17.5.5 PICS proforma for the type 10BASE-FB MAU

None.

## 17.5.6 PICS proforma for the type 10BASE-FB MAU

### 17.5.6.1 Compatibility considerations

Item	Feature	Subclause	Value/Comment	Status	Support
CC1	Compatibility Considerations: 10BASE-FB Systems compatible at 10BASE-FB MDI	15.1.3.2		M	Yes [ ]
CC2	Mode of operation	15.1.3.5	normal mode only	M	Yes [ ]

### 17.5.6.2 Optical transmit parameters

Item	Feature	Subclause	Value/Comment	Status	Support
OT1	Center wavelength	15.2.1.1	min. 800 nm max. 910 nm	M	Yes [ ]
OT2	Spectral width (FWHM)	15.2.1.2	< 75 nm	M	Yes [ ]
OT3	Optical modulation extinction ratio	15.2.1.3	< -13 dB	M	Yes [ ]
OT4	Optical idle signal amplitude	15.2.1.4	See 15.2.1.10	M	Yes [ ]
OT5	Optical transmit pulse logic polarity	15.2.1.5	High Optical Power=LO on AUI DO and MDI. Low Optical Power=HI on AUI DO and MDI	M	Yes [ ]
OT6	Optical transmit pulse rise and fall times Max. (Data) Min. (Data) Max. difference (Data) Max. (Idle) Min. (Idle) Max. difference (Idle)	15.2.1.6	Measured from 10% to 90% level 10.0 ns 0.0 ns 3.0 ns 10.0 ns 0.0 ns 3.0 ns	M	Yes [ ]
OT7				M	Yes [ ]
OT8				M	Yes [ ]
OT9				M	Yes [ ]
OT10				M	Yes [ ]
OT11				M	Yes [ ]
OT12	Optical Transmit Pulse Overshoot	15.2.1.7	< 25%	M	Yes [ ]
OT13	Optical Transmit Pulse Undershoot	15.2.1.7	< 10%	M	Yes [ ]
OT14	Optical Transmit Pulse Edge Jitter Added Total at MDI (Data) Total at MDI (Idle)	15.2.1.8	Measured as in 15.2.1.8 ± 2.0 ns ± 4.0 ns	M	Yes [ ]
OT15				M	Yes [ ]
OT16	Optical Transmit Pulse Duty Cycle Distortion Max. (Data) Max. (Idle)	15.2.1.9	Measured at median power level ± 2.5 ns ± 2.5 ns	M	Yes [ ]
OT17				M	Yes [ ]
OT18	Optical Transmit Average Power Range Min. Max.	15.2.1.10	-20 dBm -12 dBm	M	Yes [ ]
OT19				M	Yes [ ]
OT20	Transmit Signal Templates	Figure 15-4	Optical signals within template	M	Yes [ ]

**17.5.6.3 Optical receive parameters**

Item	Feature	Subclause	Value/Comment	Status	Support
OR1	BER between two AUIs attached to a single segment	15.2.2	< one part in $10^9$ (measurement made by inference)	M	Yes [ ]
OR2 OR3	Optical Receive Average Power Min. Max.	15.2.2.1	When a single transmitter transmits on the medium –32.5 dBm –12.0 dBm	M M	Yes [ ] Yes [ ]
OR4 OR5	MAU optical receive Edge Jitter (Data) Received at MDI Total at DI circuit (MAU end of AUI)	15.2.2.2	Measured as in 15.2.2.2 $\pm 2.0$ ns at median $\pm 6.5$ ns at zero crossing points	M M	Yes [ ] Yes [ ]
OR6	Optical Receive Pulse Logic Polarity	15.2.2.3	High Optical Power = LO on AUI DI and MDI. Low Optical Power = HI on AUI DI and MDI.	M	Yes [ ]
OR7 OR8 OR9 OR10 OR11 OR12	Optical Receive Pulse Rise and Fall Times Max. (Data) Min. (Data) Max. difference (Data) Max. (Idle) Min. (Idle) Max. difference (Idle)	15.2.2.4	Measured from 10% to 90% level 31.5 ns 0.0 ns 3.0 ns 31.5 ns 2.0 ns 3.0 ns	M M M M M M	Yes [ ] Yes [ ] Yes [ ] Yes [ ] Yes [ ] Yes [ ]

**17.5.6.4 Optical medium connector plug and socket**

Item	Feature	Subclause	Value/Comment	Status	Support
CS1	Connector socket	15.3.2	BFOC/2.5—see IEC 60874-10:1992	M	Yes [ ]

### 17.5.6.5 MAU functions

Item	Feature	Subclause	Value/Comment	Status	Support
MF1	Transmit data	17.3.1.1		M	Yes [ ]
MF2	Transmit SIDL	17.3.1.2		M	Yes [ ]
MF3	Transmit RF	17.3.1.3		M	Yes [ ]
MF4	Data Loopback	17.3.4		M	Yes [ ]
MF5	Receive data	17.3.2.1		M	Yes [ ]
MF6	Receive SIDL	17.3.2.2		M	Yes [ ]
MF7	Receive RF	17.3.2.2		M	Yes [ ]
MF8	Collision Presence	17.3.3		M	Yes [ ]
MF9	Fault Handling	17.3.5		M	Yes [ ]
MF10	Jabber	17.3.6		M	Yes [ ]
MF11	Low light level detect	17.3.7		M	Yes [ ]

### 17.5.6.6 PMA-to-MDI OTD messages and signaling

Item	Feature	Subclause	Value/Comment	Status	Support
OTD1	Repeater port to MAU PMA messages	17.2	As in 7.2.1 and 15.5.4	M	Yes [ ]
OTD2	Signal sent on OTD corresponding to <i>OTD_output</i> message	17.2.2	CD1,CD0	M	Yes [ ]
OTD3	Signal sent on OTD corresponding to <i>OTD_sync_idle</i> message	17.2.2	SIDL (i.e., MV1, MV1, MV0, MV0)	M	Yes [ ]
OTD4	Signal sent on OTD corresponding to <i>OTD_remote_fault</i> message	17.2.2	RF (i.e., MV1, MV1, MV1, MV0, MV0, MV0)	M	Yes [ ]
OTD5	Signal sent on OTD when repeater port is partitioned	17.2.2.3	SIDL (i.e., MV1, MV1, MV0, MV0)	M	Yes [ ]
OTD6	Synchronization of transmitted signals	17.2.2	To local bit clock	M	Yes [ ]
OTD7	AUI	17.1.1	Logical service interface only	M	Yes [ ]



**17.5.6.7 MDI ORD-to-PMA messages and signaling**

Item	Feature	Subclause	Value/Comment	Status	Support
ORD1	Signal received on ORD corresponding to <i>ORD_input</i> message	17.2.3.2	CD1, CD0	M	Yes [ ]
ORD2	Signal received on ORD corresponding to <i>ORD_sync_idle</i> message	17.2.3.3	SIDL (i.e., MV1,MV1, MV0,MV0)	M	Yes [ ]
ORD3	Signal received on ORD corresponding to <i>ORD_remote_fault</i> message	17.2.3.4	RF (i.e., MV1,MV1, MV1, MV0,MV0,MV0)	M	Yes [ ]
ORD4	Signal received on ORD corresponding to <i>ORD_invalid_data</i> message	17.2.3.5	Not CD0, CD1, SIDL, or RF	M	Yes [ ]

**17.5.6.8 Transitions between signals**

Item	Feature	Subclause	Value/Comment	Status	Support
TBS1	SIDL to data transition	17.2.4	Only at any bit cell boundary	M	Yes [ ]
TBS2	Start of SIDL	17.2.4	End of last bit cell of packet. Start with first MV1 of signal.	M	Yes [ ]
TBS3	Start of RF	17.2.4	Next bit cell boundary following fault detection. Start with first MV1 of signal.	M	Yes [ ]
TBS4	Transition between status signals	17.2.4	Only after signal sequence has been completed	M	Yes [ ]
TBS5	Interpretation of signal containing alternating MV0 and MV1, starting with MV0	17.2.4	CD0, CD1	M	Yes [ ]

**17.5.6.9 Signaling rate**

Item	Feature	Subclause	Value/Comment	Status	Support
SR1	Signaling rate	17.2.5	As in 7.3.2	M	Yes [ ]

### 17.5.6.10 Transmit functions

Item	Feature	Subclause	Value/Comment	Status	Support
XT1	Data Transmit Path for <i>output</i> message	17.3.1	Repeater unit to MDI OTD circuit	M	Yes [ ]
XT2	Levels and timing of optical signal	17.3.1	15.2.1	M	Yes [ ]
XT3	Transition from one signal to another	17.3.1	17.2.4	M	Yes [ ]
XT4	Data Transmit	17.3.1.1	Receives <i>output</i> message and sends it on the MDI OTD circuit	M	Yes [ ]
XT5	Information received from repeater and passed to MDI OTD	17.3.1.1	All	M	Yes [ ]
XT6	Information passed to MDI OTD that was not received from repeater	17.3.1.1	None	M	Yes [ ]
XT7	Conditions for SIDL transmission on OTD circuit of the MDI	17.3.1.2	Whenever repeater sends <i>idle</i> message and the PMA is not sending the <i>OTD_remote_fault</i> message	M	Yes [ ]
XT8	Conditions for RF transmission on OTD circuit of the MDI	17.3.1.3	Whenever <i>receive_jabber</i> , <i>low_light</i> , or unqualified input signal is detected at port's receive MDI	M	Yes [ ]
XT9	Maximum start-up and steady-state delay circuit of the MDI	17.3.1.1	2 BT between <i>output</i> message and transmission on MDI	M	Yes [ ]

### 17.5.6.11 Receive functions

Item	Feature	Subclause	Value/Comment	Status	Support
RCV1	Data Receive Path for <i>input</i> or <i>idle</i> message	17.3.2	MDI ORD circuit to repeater unit	M	Yes [ ]
RCV2	Optical to Electrical conversion	17.3.2	15.2.2.3	M	Yes [ ]

**17.5.6.12 Data receive function**

Item	Feature	Subclause	Value/Comment	Status	Support
DR1	Bits of information received from ORD MDI and not passed to repeater	17.3.2.1	None	M	Yes [ ]
DR2	Bits of information passed to repeater other than those received from ORD MDI	17.3.2.1	None	M	Yes [ ]
DR3	Signals detected as <i>ORD_invalid_data</i>	17.3.2.1	Signals with transitions not meeting 17.2.4 requirements	M	Yes [ ]
DR4	Action when CD0 or CD1 is received on ORD MDI	17.3.2.1	Send <i>input</i> message to repeater	M	Yes [ ]
DR5	Maximum start-up and steady-state delay	17.3.2.1	2 BT from reception on MDI to <i>input</i> message	M	Yes [ ]
DR6	Action when <i>ORD_invalid_data</i> message is received	17.3.2.1	Prevent data transmission	M	Yes [ ]

**17.5.6.13 Remote status message handling**

Item	Feature	Subclause	Value/Comment	Status	Support
RSM1	Action when SIDL or RF is received on ORD MDI	17.3.2.2	Send <i>input_idle</i> message to repeater	M	Yes [ ]
RSM2	Action when RF is received on ORD MDI	17.3.2.2	Prevent data transmission	M	Yes [ ]
RSM3	Action when <i>ORD_remote_fault</i> or <i>ORD_invalid_data</i> is received	17.3.2.2	Prevent <i>output</i> message from the repeater	M	Yes [ ]

**17.5.6.14 Collision function requirements**

Item	Feature	Subclause	Value/Comment	Status	Support
CF1	Collision Detected	17.3.3.1	Simultaneous occurrence of <i>output</i> and <i>ORD_input</i> .	M	Yes [ ]
CF2	Action when collision detected	17.3.3.1	Send <i>signal_quality_error</i> to repeater within 3.5 BT	M	Yes [ ]

### 17.5.6.15 End of collision

Item	Feature	Subclause	Value/Comment	Status	Support
EOC1	End of collision determination	17.3.3.2	<i>OTD_sync_idle</i> or messages other than <i>ORD_input</i> received from ORD circuit	M	Yes [ ]
EOC2	Action when end of collision is detected	17.3.3.2	Send <i>mau_available</i> message and idle message to repeater within 5 BT	M	Yes [ ]

### 17.5.6.16 Loopback function

Item	Feature	Subclause	Value/Comment	Status	Support
LP1	MAU transmitting on OTD and not receiving <i>ORD_input</i> message on the ORD circuit	17.3.4	Transmit <i>output</i> messages as <i>input</i> messages or transmit <i>output_idle</i> messages as <i>input_idle</i> messages	M	Yes [ ]
LP2	Steady-state propagation delay	17.3.4	≤ 2 BT	M	Yes [ ]

### 17.5.6.17 Fault-handling function

Item	Feature	Subclause	Value/Comment	Status	Support
FH1	Types of faults detected	17.3.5	Local and remote	M	Yes [ ]
FH2	Signal at OTD MDI for different fault conditions	17.3.5	See 17.3.5	M	Yes [ ]
FH3	Action during reception of remote fault signals	17.3.5	Transmit SIDL unless local fault detected	M	Yes [ ]

**17.5.6.18 Jabber-handling function**

Item	Feature	Subclause	Value/Comment	Status	Support
JAB1	Sending of <i>input</i> message to repeater during jabber	17.3.6	Inhibit	M	Yes [ ]
JAB2	Transmission of <i>OTD_sync_idle</i> during jabber	17.3.6	Disabled	M	Yes [ ]
JAB3	rcv_max_timer	17.3.6	8 ms min., 12 ms max.	M	Yes [ ]
JAB4	Message sent to repeater during jabber	17.3.6	signal_quality error	M	Yes [ ]
JAB5	Receive unjabber timer duration	17.3.6	0.5 s ± 0.25 s	M	Yes [ ]
JAB6	Detection of jabber	17.3.6	Reception ≥ rcv_max_timer	M	Yes [ ]
JAB7	MAU self-interrupt	17.3.6	As in Figure 17-3	M	Yes [ ]
JAB8	Message sent to OTD MDI during jabber	17.3.6	OTD_remote_fault	M	Yes [ ]
JAB9	Message sent to OTD MDI on power reset or after rcv_unjab_timer	17.3.6	OTD_sync_idle	M	Yes [ ]

**17.5.6.19 Low light detection**

Item	Feature	Subclause	Value/Comment	Status	Support
LLD1	Low light detection	17.3.7	Interrupt reception of signals from ORD MDI when receive optical power does not support BER of 1 part in $10^{10}$ for between 30 BT and 2000 BT	M	Yes [ ]
LLD2	Low light not detected	17.3.7	Average receive optical power > -32.5 dBm for 0.5 MHz to 25 MHz frequency band	M	Yes [ ]
LLD3	End of low light	17.3.7	Resume reception of signals from ORD MDI when receive optical power is more than needed to support BER of 1 part in $10^{10}$	M	Yes [ ]
LLD4	State of Data Receive	17.3.7	Disabled	M	Yes [ ]
LLD5	State of Data Transmit	17.3.7	Disabled	M	Yes [ ]
LLD6	Signal sent on OTD MDI during low light	17.3.7	RF	M	Yes [ ]
LLD7	Low light state exit timer	17.3.7	0.5 s ± 0.25 s	M	Yes [ ]

### 17.5.6.20 Synchronous qualification

Item	Feature	Subclause	Value/Comment	Status	Support
SQ1	Condition for interrupt of reception at MDI	17.3.8	When reliable reception cannot be assured	M	Yes [ ]
SQ2	Synchronous signaling qualification	17.3.8	SIDL or RF detected for the duration of a period between 64 BT and 128 BT of clock recovery valid	M	Yes [ ]
SQ3	Action on successful synchronous signaling qualification	17.3.8	Data Transmit = enabled Data Receive = enabled	M	Yes [ ]
SQ4	Action on loss of synchronous signaling qualification	17.3.8	Data Transmit = disabled Data Receive = disabled <i>OTD_remote_fault</i> sent on MDI	M	Yes [ ]
SQ5	Clock recovery jitter tolerance	17.3.8	As in 15.2.2.1	M	Yes [ ]
SQ6	<i>lock_lost</i> not true	17.3.8	As in 15.2.2	M	Yes [ ]
SQ7	<i>lock_lost</i> true	17.3.8	Within 20 $\mu$ s when input frequency on ORD $\geq$ 15.5 MHz or $\leq$ 1.55 MHz	M	Yes [ ]

### 17.5.6.21 MAU state diagram requirements

Item	Feature	Subclause	Value/Comment	Status	Support
SD1	Synchronous Qualification function state diagram	17.3.10	Meets requirements of Figure 17-2	M	Yes [ ]
SD2	Receive Jabber function state diagram	17.3.10	Meets requirements of Figure 17-3	M	Yes [ ]
SD3	MAU Transmit, Receive, Loop-back and Collision Presence Functions state diagram	17.3.10	Meets requirements of Figure 17-4	M	Yes [ ]

### 17.5.6.22 MAU reliability

Item	Feature	Subclause	Value/Comment	Status	Support
MR1	Mean Time Before Failure	15.4	$> 10^7$ hours without causing communications failure among other stations	M	Yes [ ]

**17.5.6.23 PLS–PMA requirements**

Item	Feature	Subclause	Value/Comment	Status	Support
PMA1	Messages between PLS in Repeater and PMA	15.5.4	As in 7.2.1	M	Yes [ ]

**17.5.6.24 *signal\_quality\_error* message (SQE)**

Item	Feature	Subclause	Value/Comment	Status	Support
SQE1	Local MAU transmitting and no collision or fault detected	15.5.4.2.1	<i>MAU_available</i> message sent to repeater	M	Yes [ ]
SQE2	Whenever a collision exists as described in 17.3.3	15.5.4.2.1	<i>signal_quality_error</i> message sent to repeater	M	Yes [ ]
SQE3	Message sent in the absence of SQE	15.5.4.2.1	<i>MAU_available</i> message	M	Yes [ ]

**17.5.6.25 Environmental requirements**

Item	Feature	Subclause	Value/Comment	Status	Support
E1	Ambient plane wave field in which MAU meets specification	15.6.2	2 V/m from 10 kHz to 30 MHz. 5 V/m from 30 MHz to 1 GHz.	M	Yes [ ]
E2	Electromagnetic emissions and susceptibility	15.6.2	Comply with local and/or national requirements. If none exist, comply with CISPR 22: 1993.	M	Yes [ ]

**17.5.6.26 MAU labeling**

Item	Feature	Subclause	Value/Comment	Status	Support
LBL1	MAU Type	15.7	10BASE-FB	O	Yes [ ] No [ ]
LBL2	Data Rate	15.7	10 Mb/s	O	Yes [ ] No [ ]
LBL3	Safety Warnings	15.7	Any applicable	O	Yes [ ] No [ ]
LBL4	Port Labeling	15.7	Input and output	O	Yes [ ] No [ ]





## 18. Fiber optic medium attachment unit, type 10BASE-FL

### 18.1 Scope

#### 18.1.1 Overview

This clause, along with Clause 15, defines the functional, electrical, optical, and mechanical characteristics of a fiber optic link for interconnecting DTEs and repeaters. The relationship of this specification to the entire ISO/IEC 8802-3 LAN International Standard is shown in Figure 15-1c). This link, which may be interconnected to other 10 Mb/s baseband segments using repeaters, consists of a 10BASE-FL MAU (including a fiber optic MDI specified in 15.2), and the fiber optic medium specified in 15.3. The purpose of the MAU is to provide a simple, inexpensive, and flexible means of attaching devices to the LAN medium.

##### 18.1.1.1 10BASE-FL medium attachment unit (MAU)

The 10BASE-FL MAU has the following general characteristics:

- a) It enables coupling the PLS by way of the AUI to the baseband fiber link defined in Clause 15.
- b) It supports message traffic at a data rate of 10 Mb/s.
- c) It provides for operating over 0 to at least 2000 m of the fiber optic cable specified in 15.3 without the use of a repeater.
- d) It permits the DTE or repeater to confirm operation of the MAU and availability of the medium.
- e) It supports network configurations using the CSMA/CD access method defined in ISO/IEC 8802-3 with baseband signaling.
- f) It supports a point-to-point interconnection between MAUs and, when used with repeaters having multiple ports, supports a star wiring topology.
- g) It allows incorporation of the MAU within the physical bounds of a DTE or repeater.

##### 18.1.1.2 Repeater unit

The repeater unit is used to extend the physical system topology and provides for coupling two or more segments. Repeaters are an integral part of all 10BASE-FL networks with more than two DTEs (see Figure 13-1 and Figure 13-2). The repeater unit is defined in Clause 9. Multiple repeater units are permitted within a single collision domain to provide the maximum connection path length specified in Clause 13. The repeater unit is not a DTE and therefore has slightly different requirements for its attached MAUs as defined in 9.4.1. It is recommended that repeater sets with 10BASE-FL MAUs provide the Auto Partition/Reconnection algorithm on those ports as specified in 9.6.6.2.

## 18.2 PMA interface messages

The messages between the PLS in the DTE and the PMA in the MAU shall comply with the PMA interface messages described in 7.2.1. These messages also are used in repeater unit to PMA communication. The messages between the PMA and the PLS in the DTE are specified in 15.5.4.1 and 15.5.4.2. These messages are also used in repeater unit to PMA communications. The messages between the PMAs and the fiber optic link segment are summarized in the following subclauses.

### 18.2.1 PMA to fiber optic link segment messages

The following messages can be sent by the MAU PMA to the Fiber Optic Link Segment:

Message	Circuit	Signal	Meaning
<i>OTD_output</i>	OTD	CD1, CD0	Output information
<i>OTD_idle</i>	OTD	OPT_IDL	No information to output

#### 18.2.1.1 *OTD\_output*.

The PMA sublayer sends the *OTD\_output* message to the OTD (Optical Transmit Data) circuit when the DTE or repeater outputs a bit of data, the MAU is available and is in the link test pass state. The physical realization of the *OTD\_output* message shall be a CD0 or CD1 signal sent by the PMA. The encoding for CD1 and CD0 is the same as used on the AUI. Retiming of the CD1 and CD0 signals within the MAU is neither prohibited nor required.

#### 18.2.1.2 *OTD\_idle*

The PMA sublayer sends the *OTD\_idle* message to the OTD circuit when the DTE or repeater sends idle; or upon detection of jabber or link integrity test failure. The physical realization of the *OTD\_idle* message shall be the OPT\_IDL defined in 18.3.1.1.

### 18.2.2 Fiber optic link segment to PMA messages

The following messages can be received by the MAU PMA from the Fiber Optic Link Segment:

Message	Circuit	Signal	Meaning
<i>ORD_input</i>	ORD	CD1, CD0	Input information
<i>ORD_idle</i>	ORD	OPT_ILD	No information to input

#### 18.2.2.1 *ORD\_input*

When the PMA sublayer receives the *ORD\_input* message on its ORD (Optical Receive Data) circuit, it detects a bit of data. The physical realization of the *ORD\_input* message shall be a CD0 or CD1 signal.

#### 18.2.2.2 *ORD\_idle*

When the PMA sublayer receives the *ORD\_idle* message on its ORD circuit, it detects idle. The physical realization of the *ORD\_idle* message shall be the OPT\_IDL signal defined in 18.3.1.1.

### 18.2.3 Interface message time references

Delay and bit loss specifications are measured from the occurrence of messages at the MDI and MAU AUI. A “positive-going” transition is from LO to HI. The following describes the point where each message starts:

Message	Reference
<i>output</i>	leading bit cell boundary (BCB) of first valid CD1 or CD0
<i>output_idle</i>	last positive-going transition prior to start of IDL
<i>input</i>	leading BCB of first valid CD1 or CD0
<i>input_idle</i>	last positive-going transition prior to start of IDL
<i>signal_quality_error</i>	first transition of valid amplitude
<i>mau_available</i>	last positive-going transition prior to start of IDL
<i>OTD_output</i>	leading BCB of first valid CD1 or CD0
<i>OTD_idle</i>	last positive going transition prior to start of OPT_IDL
<i>ORD_output</i>	leading BCB of first valid CD1 or CD0
<i>ORD_idle</i>	last positive-going transition prior to start of OPT_IDL

### 18.3 MAU functional specifications

The MAU provides the means by which signals on the three AUI signal circuits to and from the DTE or repeater and their associated interlayer messages are coupled to the fiber optic link segment. The MAU provides the following functional capabilities to handle message flow between the DTE or repeater and the fiber optic link segment:

- a) Transmit function. Provides the ability to transfer Manchester-encoded data from the DO circuit to the OTD circuit. While not sending Manchester-encoded data on the OTD circuit, an idle signal, OPT\_IDL, is sent on the OTD circuit.
- b) Receive function. Provides the ability to transfer Manchester-encoded data from the ORD circuit to the DI circuit. While not sending Manchester-encoded data on the DI circuit, an idle signal, IDL, is sent on the DI circuit.
- c) Loopback function (half duplex mode only). Provides the ability to transfer Manchester-encoded data from the DO to the DI circuit when the MAU is sending Manchester-encoded data to the OTD circuit.
- d) Collision Presence function. Provides the ability to detect simultaneous occurrence of Manchester-encoded data on the ORD and DO circuits and to report such an occurrence as a collision.
- e) *signal\_quality\_error* Message (SQE) Test function. Provides the ability to indicate to the DTE that the Collision Presence function is operational and that the *signal\_quality\_error* message can be sent by the MAU.
- f) Jabber function. Provides the ability to prevent abnormally long reception of Manchester-encoded data on the DO circuit from indefinitely disrupting transmission on the network. While such a condition is present, transfer of Manchester-encoded data by the Transmit and Loopback functions is disabled.
- g) Link Integrity Test function. Provides the ability to protect the network from the consequences of failure of the simplex link attached to the ORD circuit. While such a failure is present, transfer of Manchester-encoded data by the Transmit, Receive, and Loopback functions is disabled.

#### 18.3.1 MAU functions

The MAU shall provide the Transmit, Receive, Loopback, Collision Presence, Jabber, and Link Integrity Test functions for half duplex mode DTEs and repeater units. The MAU shall provide the Transmit, Receive,

Jabber, and Link Integrity Test functions, and shall not provide the Loopback function, for full duplex mode DTEs. The SQE Test function shall be performed by MAUs that are connected to half duplex DTEs and shall not be performed by MAUs that are connected to repeaters.

MAUs connected to full duplex mode DTEs are permitted, but not required, to implement the Collision Presence function, the SQE Test function, and the generation of the CS0 signal on the CI circuit by the Jabber function. If these optional capabilities are implemented in a MAU connected to a full duplex mode DTE, either all of the optional functions shall be implemented, or none of them shall be.

The MAU function requirements are summarized in the table below:

<b>MAU connected to:</b>			
<b>Function</b>	<b>Repeater</b>	<b>Half duplex DTE</b>	<b>Full duplex DTE</b>
Transmit	Required	Required	Required
Receive	Required	Required	Required
Loopback	Required	Required	Prohibited
Jabber	Required	Required	Required
Link Integrity Test	Required	Required	Required
Collision Presence	Required	Required	Optional (note 2)
SQE Test	Prohibited	Required	Optional (note 2)
Generation of CS0 signal on the CI circuit by Jabber	Required	Required	Optional (note 2)

NOTE 1—The functional requirements of a MAU connected to a full duplex DTE are a proper subset of the requirements for half duplex operation.

NOTE 2—Optional capabilities, if implemented, must be implemented as a group (i.e., all or none).

A capability may be provided in the MAU to activate or inhibit the SQE Test function or to configure the MAU for full or half duplex operation. It is not required that a MAU determine that it is connected to either a DTE or a repeater and automatically activate or inhibit the SQE Test function. It is also not required that a MAU determine that it is connected to either a half duplex or full duplex DTE and automatically activate or inhibit the appropriate functions for those modes.

### 18.3.1.1 Transmit function requirements

The MAU shall receive messages on the DO circuit and send the appropriate signals to the OTD circuit of the MDI.

At the start of a packet transmission, no more than 2 bits shall be received from the DO circuit and not transmitted on the OTD circuit. In addition, it is permissible for the first bit sent to contain phase violations or invalid amplitude. All subsequent bits of the packet shall be reproduced with levels and timing meeting the specifications of 15.2.1. The second bit transmitted on the OTD circuit shall be transmitted with the correct timing and signal levels. The steady-state propagation delay between the DO circuit input and the OTD circuit shall not exceed 2.0 BT.

For any two packets that are separated by 9.6 ms or less, the start-up delay (bit loss plus steady-state propagation delay) of the first packet shall not exceed that of the second packet by more than 2.0 BT.

Whenever data is not being transmitted on the OTD circuit, an idle signal, OPT\_IDL, shall be transmitted on the OTD circuit. OPT\_IDL consists of a start of idle (4 BT to 21 BT of the lower light level) followed by a periodic pulse waveform of frequency 1 MHz +25%, -15%. Following a packet and the start of idle, the periodic pulse wave form shall start with a transition to the higher optical light level.

Transmission of OPT\_IDL may be terminated at any time with respect to the periodic pulse waveform. It shall be terminated such that no more than the first transmitted bit of a packet is corrupted, and with no more delay than is specified for bit loss and steady-state propagation.

### 18.3.1.2 Receive function requirements

The MAU shall receive the signals on the ORD circuit of the MDI and send the appropriate message to the DI circuit. The optical-to-electrical conversion shall be as specified in 15.2.2.3.

At the start of a packet reception from the ORD circuit, no more than 2 bits shall be received on the ORD circuit and not transmitted onto the DI circuit. In addition, it is permissible for the first bit sent on the DI circuit to contain phase violations or invalid data; however, all successive bits of the packet shall be sent with no more than the amount of jitter specified in 15.2. The steady-state propagation delay between the ORD circuit and the DI circuit shall not exceed 2.0 BT.

For any two packets that are separated by 9.6  $\mu$ s or less, the start-up delay of the first packet shall not exceed that of the second packet by more than 2.0 BT.

### 18.3.1.3 Loopback function requirements (half duplex mode only)

When the MAU is transmitting on the OTD circuit and is not receiving *ORD\_input* messages (18.2.2.1) on the ORD circuit, the MAU shall transmit on the DI circuit the signals received on the DO circuit in order to provide loopback of the transmitted signal. At the start-of-packet transmission on the OTD circuit, no more than 5 bits of information shall be received from the DO circuit and not transmitted to the DI circuit. In addition, it is permissible for the first bit sent on the DI circuit to contain phase violations or invalid data; however, all successive bits of the packet shall meet the jitter specified in 15.2. The steady-state propagation delay between the DO circuit and the DI circuit shall not exceed 1.0 BT.

### 18.3.1.4 Collision Presence function requirements (half duplex mode only)

The MAU shall detect as a collision the simultaneous occurrence of activity on the DO circuit and the ORD circuit while in the Link Test Pass state. While a collision is detected, a CS0 signal (see 7.3.1.2) shall be sent on the CI circuit. The signal shall be presented to the CI circuit no more than 3.5 BT after the occurrence of a collision. The signal shall be de-asserted within 7.0 BT after the DO circuit or the ORD circuit changes from active to idle.

When CS0 is asserted on the CI circuit due to a collision, the data on the ORD circuit shall be sent to the DI circuit within 9.0 BT.

When the ORD circuit changes from active to idle and data is present on the DO circuit, the data on the DO circuit shall be sent to the DI circuit within 7.0 BT.

The signal presented on the CI circuit in the absence of collision, SQE test, or Jabber shall be the IDL signal.

MAUs connected to full duplex mode DTEs are permitted, but not required, to implement the Collision Presence function (see 18.3.1).

### 18.3.1.5 *signal\_quality\_error* Message (SQE) Test function requirements

The SQE Test function shall be performed by MAUs that are connected to DTEs and shall not be performed by MAUs that are connected to repeaters. When the SQE test is performed, the MAU shall send CS0 on the CI circuit for a time “SQE\_test” beginning a time “SQE\_test\_wait” after the last positive transition of a packet on the DO circuit. The value of “SQE\_test” shall be 10 BT  $\pm$  5 BT and the value of “SQE\_test\_wait” shall be between 0.6 and 1.6  $\mu$ s. This function should use as much of the normal collision detection and signaling circuitry as possible without introducing extraneous signals on the OTD circuit or the DI circuit.

The CS0 signal shall not be sent by the SQE Test function while in any of the Link Test Fail states.

MAUs connected to full duplex mode DTEs are permitted, but not required to implement the SQE Test function (see 18.3.1).

### 18.3.1.6 Jabber function requirements

The MAU shall contain a self-interrupt capability to prevent an illegally long transmission by a DTE from permanently disrupting transmission on the network and to disable loopback to the DI circuit (Figure 18–3). The MAU shall provide a window “xmit\_max” during which time the Transmit function may continuously transmit *OTD\_output* messages to the OTD circuit. The value of “xmit\_max” shall be between 20 and 150 ms. If a transmission exceeds this duration, the Jabber function shall

- a) Inhibit the Loopback function and the transmission of *OTD\_output* messages by the Transmit function, and shall
- b) Send the CS0 signal on the CI circuit, when the MAU is connected to a DTE operating in half duplex mode. MAUs connected to DTEs operating in full duplex mode are permitted, but not required, to send the CS0 signal on the CI circuit in this manner (see 18.3.1).

These actions shall continue until *output\_idle* has been continuously present on the DO circuit for a time “unjab.” The value of “unjab” shall be 0.5 s  $\pm$  0.25 s.

It is permissible to activate the Jabber function when the OTD circuit transmitter is sending *OTD\_output* messages for longer than “xmit\_max.”

The MAU shall not activate its Jabber function when the repeater’s MAU Jabber Lockup Protection function operates at its longest permitted time as specified in 9.6.5.

### 18.3.1.7 Link Integrity Test function requirements

In order to protect the network from the consequences of a simplex fiber optic link segment failure, the MAU shall monitor the light level on the ORD circuit. When a light level below that required for reliable reception (low light) is detected, the MAU shall enter the Link Test Fail Low Light state and cause the *input\_idle* message to be sent on the DI circuit and the *OTD\_idle* message to be sent on the OTD circuit (Figure 18–4).

Low light shall not be detected if the optical power level at the ORD circuit exceeds  $-32.5$  dBm. Low light shall also not be detected if the low light condition remains for less than 30 BT. It shall be detected and the Link Test Fail Low Light state entered if the optical power level at ORD circuit has fallen to a level lower than the optical power level that corresponds to a BER =  $10^{-10}$  for the MAU for a duration of 2000 BT. Additionally, when the optical receive average power has maintained a value less than  $-30$  dBm for 2000 BT and then falls lower than the level that corresponds to a BER =  $10^{-10}$  for the MAU for a duration of 500 BT, low light shall be detected and the Link Test Fail Low Light state entered.

The MAU shall exit the Link Test Fail Low Light state once the optical power level on the ORD circuit exceeds  $-32.5$  dBm for 0.5 s  $\pm$  0.25 s. Exiting the Link Test Fail Extend state and entering the Link Test Pass state (thus,

re-enabling the OTD and DI circuits) shall be deferred until the signals on the ORD and DO circuits become idle. Optionally, a MAU may exit the Link Test Fail Extend state and enter the Link Test Pass state when the ORD circuit becomes idle and the Jabber function has disabled transmission on the OTD circuit.

While the MAU is not in the Link Test Pass state, the Link Integrity Test function shall disable the bit transfer of the Transmit, Receive, and Loopback functions, and the Collision Presence and SQE Test functions.

At power-on, in place of entering the Link Test Pass state as shown in Figure 18–4,<sup>38</sup> a MAU may optionally enter the Link Test Fail Low Light state.

If a visible indicator is provided on the MAU to indicate the link status, it is recommended that the color be green and that the indicator be labeled appropriately. It is further recommended that the indicator be on when the MAU is in the Link Test Pass state and off otherwise.

### 18.3.1.8 Auto-Negotiation

The Auto-Negotiation algorithm of Clause 28, while the preferred method for the determination of half or full duplex operation, is not currently defined for fiber MAUs.

Manual configuration, while not recommended for copper-based MAUs, is the only practical choice for fiber implementations. Connecting incompatible DTE/MAU combinations such as a full duplex mode DTE to a half duplex mode MAU, or a full duplex mode station (DTE and MAU) to a half duplex network, can lead to severe network performance degradation, increased collisions, late collisions, CRC errors, and undetected data corruption.

### 18.3.2 MAU state diagrams

The state diagrams of Figure 18–1a), Figure 18–1b), Figure 18–2, Figure 18–3, and Figure 18–4 depict the full set of allowed MAU state functions relative to the circuits of the AUI and MDI.

The notation used in the state diagrams follows the conventions in 1.2.1. The variables and timers used in the state diagrams are defined in the following subclauses.

#### 18.3.2.1 MAU state diagram variables

Variables are used in the state diagrams to indicate the status of MAU inputs and outputs, to control MAU operation, and to pass state information between functions.

In the variable definitions, the name of the variable is followed by a brief description of the variable and a list of values the variable may take. For those variables which are state diagram outputs, one value will be identified as the default. The variable has the default value when no active state contains a term assigning a different value.

For example, the variable “xmit” has the value “disable” whenever the Jabber function or the Link Integrity Test function is in a state that asserts “xmit=disable”. The variable has the default value “enable” all other times.

---

<sup>38</sup>The MAU state diagrams, Figures 18–1 through 18–4, follow 18.3.2.2.

The variables used in the state diagrams are defined as follows:

DI

Controls the signal sent by the MAU on the DI circuit.  
Values: *idle*; MAU is sending *input\_idle*, IDL (default).  
DO; MAU sends the signal received on the DO circuit.  
*lpbk* = *disable* overrides this and causes *input\_idle* to be sent.  
ORD; MAU sends the signal received on the ORD circuit.  
*rcv* = *disable* overrides this and causes *input\_idle* to be sent.

CI

Controls the signal sent by the MAU on the CI circuit.  
Values: *idle*; MAU sends *mau\_available*, IDL (default).  
SQE; MAU sends *signal\_quality\_error*, CS0.

DO

Status of the signal received by the MAU on the DO circuit.  
Values: *idle*; MAU is receiving *output\_idle*, IDL.  
*active*; MAU is receiving *output*, CD0 or CD1.

OTD

Controls the signal sent by the MAU on the OTD circuit.  
Values: *idle*; MAU sends *OTD\_idle*, OPT\_IDL (default).  
DO; MAU sends the signal received on the DO circuit.  
*xmit* = *disable* overrides this and causes *OTD\_idle* to be sent.

ORD

Status of the signal received by the MAU on the ORD circuit.  
Values: *idle*; MAU is receiving *ORD\_idle*; OPT\_idle.  
*active*; MAU is receiving *ORD\_input*; CD0 or CD1.

*low\_light\_level*

Status of the light level received by the MAU on the ORD circuit.  
Values: *false*; MAU is receiving sufficient light level for reliable reception.  
*true*; MAU is not receiving sufficient light level for reliable reception (see 18.3.1.7).

*rcv*

Controls the path from the ORD circuit to the DI circuit.  
Values: *enable*; receive is enabled (default).  
*disable*; the output to the DI circuit will be *input\_idle* when DI=ORD.

*lpbk*

Controls the path from the DO circuit to the DI circuit.  
Values: *enable*; loopback is enabled (default).  
*disable*; the output to the DI circuit will be *input\_idle* when DI=DO.

*xmit*

Controls the path from the DO circuit to the OTD circuit.  
Values: *enable*; transmit is enabled (default).  
*disable*; transmit is disabled and the signal sent on the OTD circuit will be OPT\_IDL.



### 18.3.2.2 MAU state diagram timers

All timers operate in the same fashion. A timer is reset and starts counting upon entering a state where start  $x\_timer$  is asserted. Time  $x$  after the timer has been started,  $x\_timer\_done$  is asserted and remains asserted until the timer is reset. At all other times,  $x\_timer\_not\_done$  is asserted.

When entering a state where start  $x\_timer$  is asserted, the timer is reset and restarted even if the entered state is the same as the exited state.

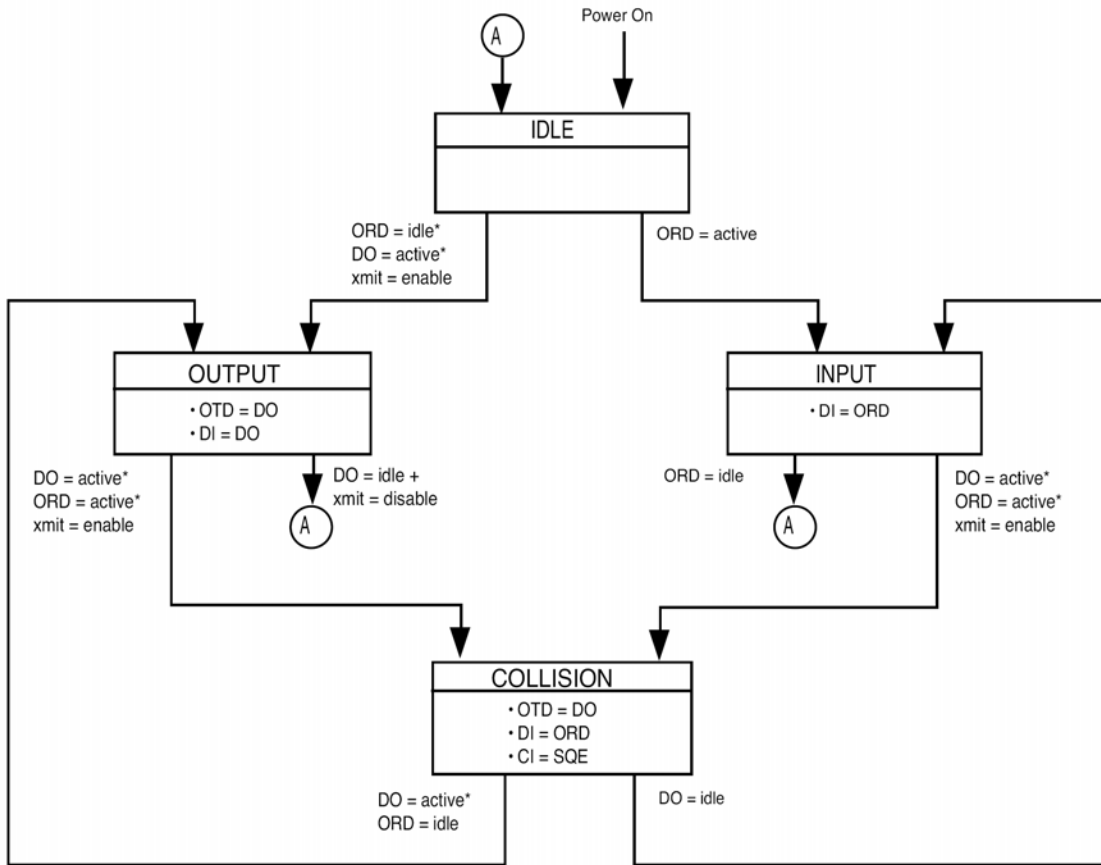
**low\_light\_heal\_timer.** Timer for low light condition cessation.

**SQE\_test\_timer.** Timer for the duration of the CS0 signal used for the SQE Test function (18.3.1.5).

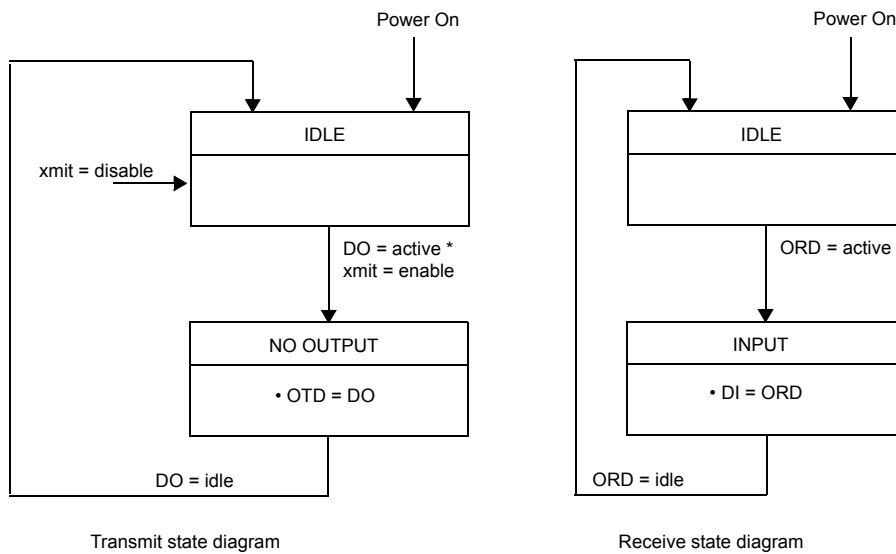
**SQE\_test\_wait\_timer.** Timer for the delay from end of packet to the start of the CS0 signal used for the SQE Test function (18.3.1.5).

**unjab\_timer.** Timer for the length of time the DO circuit must be continuously idle to allow transmission to be re-enabled (18.3.1.6).

**xmit\_max\_timer.** Timer for excessively long transmit time (18.3.1.6).



a) MAU Transmit, Receive, Loopback, and Collision Presence functions (half duplex mode)



b) MAU Transmit and Receive functions (full duplex mode)

**Figure 18-1—MAU state diagrams**

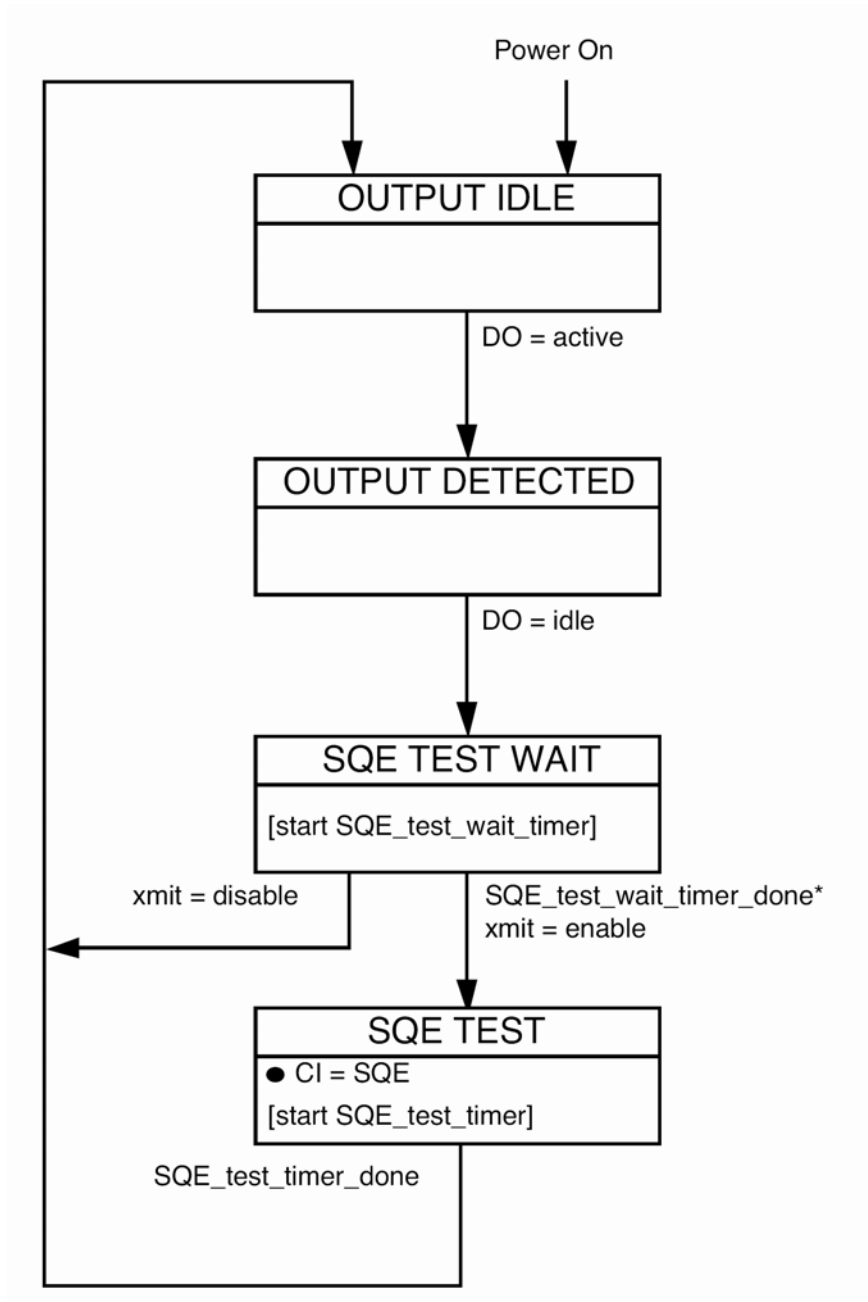
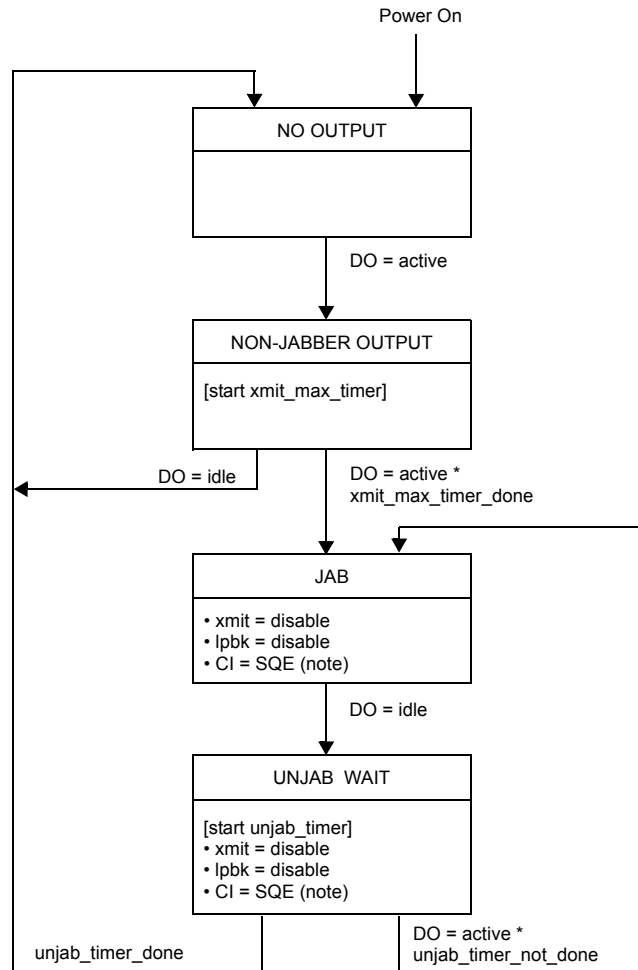


Figure 18–2—*signal\_quality\_error* Message Test function state diagram



NOTE 1—Optional for MAUs connected to DTEs operating in full duplex mode.

NOTE 2—The implementation of the Collision Presence function is not required in a MAU connected to a full duplex mode DTE, and is not shown in Figure 18-1b).

NOTE 3—The implementation of the SQE Test function shown in Figure 18-2 is not required in a MAU connected to a full duplex mode DTE.

NOTE 4—The enabling of the variable *lpbk* in Figure 18-4 is applicable in half duplex mode only.

**Figure 18-3—Jabber function state diagram**

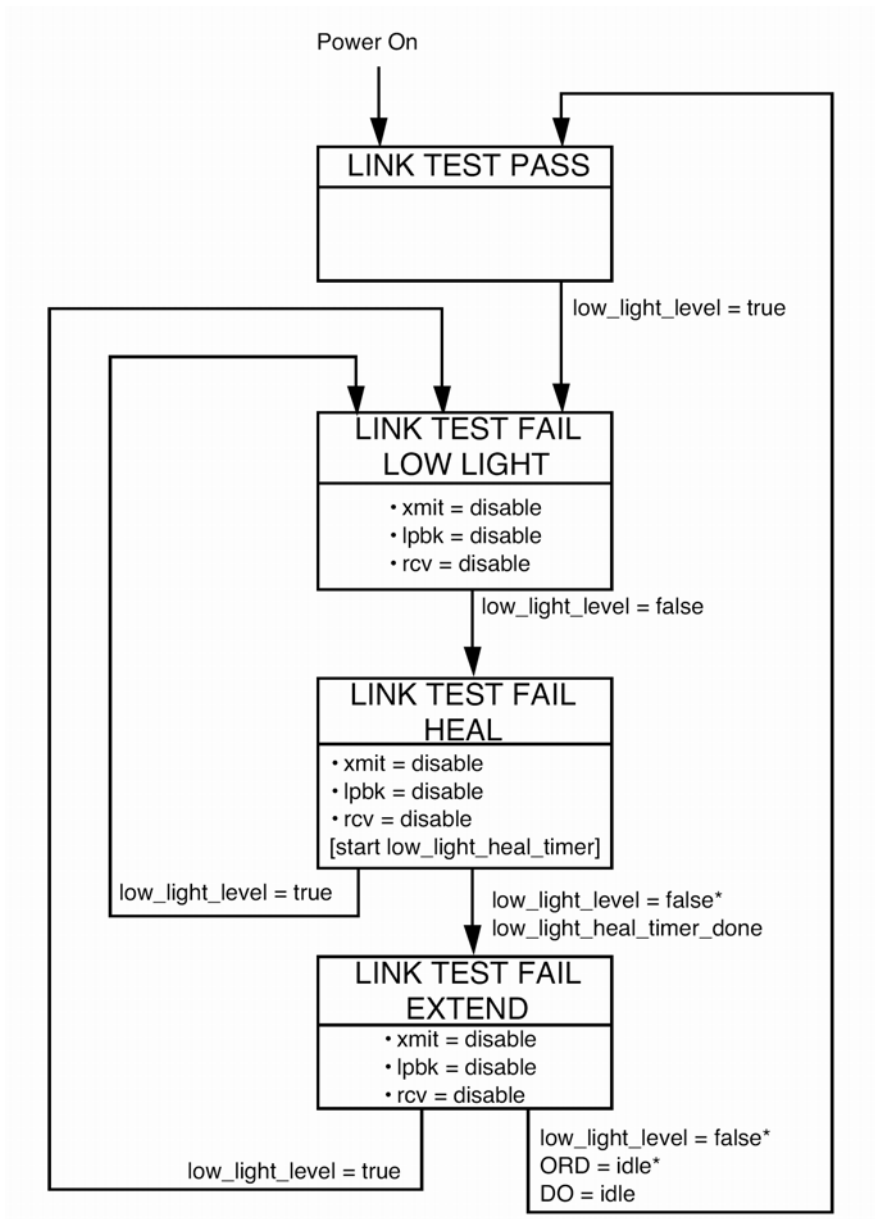


Figure 18–4—Link Integrity Test function state diagram

## 18.4 Timing summary

Table 18–1 summarizes the timing requirements for the 10BASE-FL fiber link. This table is a summary; for complete descriptions of the timing requirements, refer to the referenced clauses. All times are in bit times.

**Table 18–1—Maximum timing parameters**

Symbol	Function	Bit loss	Invalid bits	Steady-state prop. delay	Start-up delay		
					Max.	Var	Specified in
M1	<i>ORD_input</i> to <i>input</i> on DI	2.0	1.0	2.0	5.0	2.0	18.3.1.2
M2	<i>output</i> on DO to <i>OTD_output</i>	2.0	1.0	2.0	5.0	2.0	18.3.1.1
M3	<i>ORD_input</i> * <i>output</i> to <i>signal_quality_error</i>				3.5		18.3.1.4
M4	<i>ORD_idle</i> + <i>output_idle</i> (end of collision) to <i>mau_available</i>				7.0		18.3.1.4
M5	<i>ORD_input</i> * <i>output</i> to <i>input</i> on DI from circuit ORD				9.0		18.3.1.4
M6	<i>ORD_idle</i> * <i>output</i> to <i>input</i> on DI from circuit DO				7.0		18.3.1.4
M7	<i>output_idle</i> on DO to <i>signal_quality_error</i>				$6 < x < 16$		18.3.1.5
M8	<i>signal_quality_error</i> duration for SQE test				$5 \leq x \leq 15$		18.3.1.5
M9	<i>output</i> on DO to <i>input</i> on DI	5.0	1.0	1.0	7.0		18.3.1.3
F1	Fiber Optic Cable Propagation (2000 m)	0	0	100	100		15.3.1.3
A1	AUI Cable Propagation (50 m)	0	0	2.57	2.57		7.4.3.7

## 18.5 Protocol implementation conformance statement (PICS) proforma for Clause 18, Fiber optic medium attachment unit, type 10BASE-FL<sup>39</sup>

### 18.5.1 Introduction

The supplier of a protocol implementation that is claimed to conform to Clause 18, Fiber optic medium attachment unit, type 10BASE-FL, shall complete the following protocol implementation conformance statement (PICS) proforma.

A completed PICS proforma is the PICS for the implementation in question. The PICS is a statement of which capabilities and options of the protocol have been implemented. The PICS can be used for a variety of purposes by various parties, including the following:

- As a checklist by the protocol implementor, to reduce the risk of failure to conform to the standard through oversight;
- As a detailed indication of the capabilities of the implementation, stated relative to the common basis for understanding provided by the standard PICS proforma, by the supplier and acquirer, or potential acquirer, of the implementation;
- As a basis for initially checking the possibility of interworking with another implementation by the user, or potential user, of the implementation (note that, while interworking can never be guaranteed, failure to interwork can often be predicted from incompatible PICSs);
- As the basis for selecting appropriate tests against which to assess the claim for conformance of the implementation, by a protocol tester.

### 18.5.2 Abbreviations and special symbols

#### 18.5.2.1 Status symbols

The following symbols are used in the PICS proforma:

M	mandatory field/function
O	optional field/function
O.<n>	optional field/function, but at least one of the group of options labeled by the same numeral <n> is required
O/<n>	optional field/function, but one and only one of the group of options labeled by the numeral <n> is required
X	prohibited field/function
<item>:	simple-predicate condition, dependent on the support marked for <item>

#### 18.5.2.2 Abbreviations

N/A	Not applicable
-----	----------------

In addition, the following predicate names are defined for use when different implementations from the set above have common parameters:

- \*HRP : HDX or RPT
- \*HDS : HDX or FDS
- \*HFC : HDX or FDS or RPT

<sup>39</sup>Copyright release for PICS proformas: Users of this standard may freely reproduce the PICS proforma in this subclause so that it can be used for its intended purpose and may further publish the completed PICS.

### **18.5.3 Instructions for completing the PICS proforma**

#### **18.5.3.1 General structure of the PICS proforma**

The first part of the PICS proforma, Implementation Identification and Protocol Summary, is to be completed as indicated with the information necessary to identify fully both the supplier and the implementation.

The main part of the PICS proforma is a fixed-format questionnaire divided into subclauses, each containing a group of items. Answers to the questionnaire items are to be provided in the right-most column, either by simply marking an answer to indicate a restricted choice (usually Yes, No, or Not Applicable), or by entering a value or a set or range of values. (Note that there are some items where two or more choices from a set of possible answers can apply; all relevant choices are to be marked.)

Each item is identified by an item reference in the first column; the second column contains the question to be answered; the third column contains the reference or references to the material that specifies the item in the main body of the standard; the fourth column contains values and/or comments pertaining to the question to be answered. The remaining columns record the status of the item—whether the support is mandatory, optional, or conditional—and provide the space for the answers; see also 18.5.3.4 below.

The supplier may also provide, or be required to provide, further information, categorized as either Additional Information or Exception Information. When present, each kind of further information is to be provided in a further subclause of items labeled A<*i*> or X<*i*>, respectively, for cross-referencing purposes, where <*i*> is any unambiguous identification for the item (e.g., simply a numeral); there are no other restrictions on its format or presentation.

A completed PICS proforma, including any Additional Information and Exception Information, is the protocol implementation conformance statement for the implementation in question.

Note that where an implementation is capable of being configured in more than one way, according to the items listed under 18.5.5, Major Capabilities/Options, a single PICS may be able to describe all such configurations. However, the supplier has the choice of providing more than one PICS, each covering some subset of the implementation's configuration capabilities, if that would make presentation of the information easier and clearer.

#### **18.5.3.2 Additional information**

Items of Additional Information allow a supplier to provide further information intended to assist the interpretation of the PICS. It is not intended or expected that a large quantity will be supplied, and the PICS can be considered complete without any such information. Examples might be an outline of the ways in which a (single) implementation can be set up to operate in a variety of environments and configurations; or a brief rationale, based perhaps upon specific application needs, for the exclusion of features which, although optional, are nonetheless commonly present in implementations of the 10BASE-FL protocol.

References to items of Additional Information may be entered next to any answer in the questionnaire, and may be included in items of Exception Information.

#### **18.5.3.3 Exception information**

It may occasionally happen that a supplier will wish to answer an item with mandatory or prohibited status (after any conditions have been applied) in a way that conflicts with the indicated requirement. No pre-printed answer will be found in the Support column for this; instead, the supplier is required to write into the Support column an X<*i*> reference to an item of Exception Information, and to provide the appropriate rationale in the Exception item itself.



An implementation for which an Exception item is required in this way does not conform to this standard.

Note that a possible reason for the situation described above is that a defect in the standard has been reported, a correction for which is expected to change the requirement not met by the implementation.

#### 18.5.3.4 Conditional items

The PICS proforma contains a number of conditional items. These are items for which both the applicability of the item itself, and its status if it does apply—mandatory, optional, or prohibited—are dependent upon whether or not certain other items are supported.

Individual conditional items are indicated by a conditional symbol of the form “<item>:<s>” in the Status column, where “<item>” is an item reference that appears in the first column of the table for some other item, and “<s>” is a status symbol, M, O, or X.

If the item referred to by the conditional symbol is marked as supported, the conditional item is applicable, and its status is given by “<s>”; the support column is to be completed in the usual way. Otherwise, the conditional item is not relevant and the Not Applicable (N/A) answer is to be marked.

Each item whose reference is used in a conditional symbol is indicated by an asterisk in the Item column.

#### 18.5.4 Identification

##### 18.5.4.1 Implementation identification

Supplier	
Contact point for queries about the PICS	
Implementation Name(s) and Version(s)	
Other information necessary for full identification—e.g., name(s) and version(s) for machines and/or operating systems; System Name(s)	
NOTE 1—Only the first three items are required for all implementations; other information may be completed as appropriate in meeting the requirements for the identification. NOTE 2—The terms Name and Version should be interpreted appropriately to correspond with a supplier’s terminology (e.g., Type, Series, Model).	

##### 18.5.4.2 Protocol summary

Identification of protocol specification	IEEE Std 802.3-2008, Clause 18, Fiber optic medium attachment unit, Type 10BASE-FL
Identification of amendments and corrigenda to this PICS proforma which have been completed as part of this PICS	
Have any Exception items been required?      No [ ]      Yes [ ] (See 17.5.3.3; The answer Yes means that the implementation does not conform to IEEE Std 802.3-2008.)	

Date of Statement	
-------------------	--

### 18.5.5 Major capabilities/options

Item	Feature	Subclause	Value/ Comment	Status	Support
*DTE	MAU supports DTE connections	15.1.1	N/A	O.1	Yes [ ] No [ ]
*RPT	MAU supports repeater connections	15.1.1	N/A	O.1	Yes [ ] No [ ]
*AUI	AUI connection physically exists and is accessible for test.	15.1.3.2	N/A	O	Yes [ ] No [ ]
*APW	AUI powers MAU	15.5.3	N/A	AUI: O.2	N/A [ ] Yes [ ] No [ ]
*SPW	AUI implemented but MAU powered separately	15.5.3	N/A	AUI: O.2	N/A [ ] Yes [ ] No [ ]
*FDX	MAU supports full duplex mode DTE connections	15.1.3.5	N/A	DTE: O.3	N/A [ ] Yes [ ] No [ ]
*HDX	MAU supports half duplex mode DTE connections	15.1.3.5	N/A	DTE: O.3	N/A [ ] Yes [ ] No [ ]
*FDS	MAU supports optional set of SQE related function for full duplex mode DTE connections	18.3.1	N/A	FDX: O	N/A [ ] Yes [ ] No [ ]

### 18.5.6 PICS proforma tables for the type 10BASE-FL MAU

#### 18.5.6.1 Compatibility considerations

Item	Feature	Subclause	Value/Comment	Status	Support
CC1	Compatibility considerations: 10BASE-FL systems compatible at 10BASE-FL MDI	15.1.3.2		M	Yes [ ]
CC2	10BASE-FL MAUs interoperable with FOIRL MAUs except for media connector	15.1.3.2		M	Yes [ ]
CC3	Mode of operation	15.1.3.5	normal mode only	M	Yes [ ]

**18.5.6.2 Optical transmit parameter**

Item	Feature	Subclause	Value/Comment	Status	Support	
OT1	Center wavelength	15.2.1.1	min. 800 nm; max. 910 nm	M	Yes [ ]	
OT2	Spectral width (FWHM)	15.2.1.2	< 75 nm	M	Yes [ ]	
OT3	Optical modulation extinction ratio	15.2.1.3	< -13 dB	M	Yes [ ]	
OT4	Optical Idle signal amplitude	15.2.1.4	See 15.2.1.10	M	Yes [ ]	
OT5	Optical transmit pulse logic polarity	15.2.1.5	High Optical Power = LO on AUI DO and MDI. Low Optical Power = HI on AUI DO and MDI.	M	Yes [ ]	
OT6	Optical transmit pulse rise and fall times	15.2.1.6	Measured from 10% to 90% level	M	Yes [ ]	
OT7	Max. (Data)					10.0 ns
OT8	Min. (Data)					0.0 ns
OT9	Max. Difference (Data)					3.0 ns
OT10	Max. (Idle)					25.0 ns
OT11	Min. (Idle)					0.0 ns
OT11	Max. Difference (Idle)	25.0 ns				
OT12	Optical transmit pulse overshoot	15.2.1.7	< 25%	M	Yes [ ]	
OT13	Optical transmit pulse undershoot	15.2.1.7	< 10%	M	Yes [ ]	
OT14	Optical transmit pulse edge jitter added	15.2.1.8	Measured as in 15.2.1.8	M	Yes [ ]	
OT15	DO circuit to MDI Total at MDI					± 2.0 ns ± 4.0 ns
OT16	Optical transmit pulse duty cycle distortion	15.2.1.9	Measured at median power level	M	Yes [ ]	
OT17	Max. (Data) Max. (Idle)					± 2.5 ns ± 50.0 ns
OT18	Optical transmit average power range	15.2.1.10		M	Yes [ ]	
OT19	Min. Max.					-20 dBm -12 dBm
OT20	Transmit signal templates	Figure 15-5	Optical signals within template	M	Yes [ ]	

### 18.5.6.3 Optical receive parameters

Item	Feature	Subclause	Value/Comment	Status	Support
OR1	BER between two AUIs attached to a single segment	15.2.2	< one part in 10 <sup>9</sup>	M	Yes [ ]
OR2 OR3	Optical receive average power Min. Max.	15.2.2.1	When a single transmitter transmits on the medium -32.5 dBm -12.0 dBm	M M	Yes [ ] Yes [ ]
OR4 OR5 OR6	MAU optical receive Edge jitter (Data) Received at MDI Added MDI to DI circuit Total at DI circuit (MAU end of AUI)	15.2.2.2	Measured as in 15.2.2.2  ± 6.5 ns at median power ± 8.5 ns ± 15.0 ns at zero crossing points	M M M	Yes [ ] Yes [ ] Yes [ ]
OR7	Optical receive pulse logic polarity	15.2.2.3	High Optical Power = LO on AUI DI and MDI. Low Optical Power = HI on AUI DI and MDI	M	Yes [ ]
OR8 OR9 OR10 OR11 OR12 OR13	Optical receive pulse rise and fall times: Max. (Data) Min. (Data) Max. Difference (Data) Max. (Idle) Min. (Idle) Max. Difference (Idle):	15.2.2.4	Measured from 10% to 90% level  31.5 ns 0.0 ns 3.0 ns 41.0 ns 0.0 ns 25.0 ns	M M M M M M	Yes [ ] Yes [ ] Yes [ ] Yes [ ] Yes [ ] Yes [ ]

### 18.5.6.4 Optical medium connector plug and socket

Item	Feature	Subclause	Value/Comment	Status	Support
CS1	Connector socket for MAU	15.3.2	BFOC/2.5—see IEC 60874-10:1992	M	Yes [ ]

**18.5.6.5 MAU functions**

Item	Feature	Subclause	Value/Comment	Status	Support
MF1	Transmit	18.3.1.1		M	Yes [ ]
MF2	Receive	18.3.1.2		M	Yes [ ]
MF3	Loopback	18.3.1.3		HRP: M FDX: X	N/A [ ] M: Yes [ ] N/A [ ] X: Yes [ ]
MF4	Collision Presence	18.3.1.4		HFC: M	N/A [ ] M: Yes [ ]
MF5	Jabber	18.3.1.6		M	Yes [ ]
MF6	Link Integrity Test	18.3.1.7		M	Yes [ ]
MF7	SQE Test	18.3.1.5		HDS: M RPT: X	N/A [ ] M: Yes [ ] N/A [ ] X: Yes [ ]

**18.5.6.6 PMA interface messages**

Item	Feature	Subclause	Value/Comment	Status	Support
PIM1	Messages between the PLS in the DTE and the PMA in the MAU	18.2	As described in 7.2.1	M	Yes [ ]

**18.5.6.7 PMA-to-MDI OTD messages**

Item	Feature	Subclause	Value/Comment	Status	Support
OTD1	Signal sent on OTD corresponding to <i>OTD_output</i> message	18.2.1.1	CD1,CD0	M	Yes [ ]
OTD2	Signal sent on OTD corresponding to <i>OTD_idle</i> message	18.2.1.2	OPT_IDL	M	Yes [ ]

**18.5.6.8 MDI ORD-to-PMA messages**

Item	Feature	Subclause	Value/Comment	Status	Support
ORD1	Signal received on ORD corresponding to <i>ORD_input</i> message	18.2.2.1	CD1,CD0	M	Yes [ ]
ORD2	Signal received on ORD corresponding to <i>ORD_idle</i> message	18.2.2.2	OPT_IDL or signal other than valid Manchester Data	M	Yes [ ]

### 18.5.6.9 Transmit function

Item	Feature	Subclause	Value/Comment	Status	Support
XT1	Data Transmit path for <i>output</i> message	18.3.1.1	DO circuit to OTD circuit	M	Yes [ ]
XT2	Levels and timing of optical signal	18.3.1.1	As in 15.2.1	M	Yes [ ]
XT3	Start-up bit loss (DO to OTD circuits)	18.3.1.1	2 bits max.	M	Yes [ ]
XT4	Transmit settling time	18.3.1.1	Second and following bits meet jitter, level, and waveform specifications of 15.2.1	M	Yes [ ]
XT5	Transmit steady-state delay	18.3.1.1	2 BT max.	M	Yes [ ]
XT6	Transmit delay variability	18.3.1.1	2 BT max.	M	Yes [ ]
XT7	Signal sent on OTD corresponding to OPT_IDL message	18.3.1.1	Start of idle followed by a periodic pulse waveform	M	Yes [ ]
XT8	Periodic pulse waveform	18.3.1.1	1 MHz +25%, -15%	M	Yes [ ]
XT9	OPT_IDL termination with respect to start of packet	18.3.1.1	Normal start-of-packet requirement apply	M	Yes [ ]

### 18.5.6.10 Receive function

Item	Feature	Subclause	Value/Comment	Status	Support
RCV1	Optical to electrical	18.3.1.2	As specified in 15.2.2.3	M	Yes [ ]
RCV2	Receive path	18.3.1.2	ORD circuit to DI circuit	M	Yes [ ]
RCV3	Start-up bit loss (ORD to DI circuits)	18.3.1.2	2 bits max.	M	Yes [ ]
RCV4	Receive settling time	18.3.1.2	Second and following bits meet jitter specifications of 15.2	M	Yes [ ]
RCV5	Receive steady-state delay	18.3.1.2	2 BT max.	M	Yes [ ]
RCV6	Receive delay variability	18.3.1.2	2 BT max.	M	Yes [ ]

### 18.5.6.11 Loopback function

Item	Feature	Subclause	Value/Comment	Status	Support
LP1	Loopback function requirements when ORD = idle and DO = active	18.3.1.3	DO signals to DI circuit.	HRP: M	N/A [ ] M: Yes [ ]
LP2	Loopback bit loss (DO to DI circuits)	18.3.1.3	5 bits max	HRP: M	N/A [ ] M: Yes [ ]
LP3	Loopback settling time	18.3.1.3	Second and following bits meet jitter specifications.	HRP: M	N/A [ ] M: Yes [ ]
LP4	Loopback steady-state delay	18.3.1.3	1 BT max	HRP: M	N/A [ ] M: Yes [ ]

**18.5.6.12 Collision Presence function**

Item	Feature	Subclause	Value/Comment	Status	Support
CP1	Collision Presence function requirements	18.3.1.4	CS0 on CI circuit if DO=active, ORD=active and in Link Test Pass state.	HFC: M	N/A [ ] M: Yes [ ]
CP2	Collision indication delay	18.3.1.4	3.5 BT max.	HFC: M	N/A [ ] M: Yes [ ]
CP3	Collision indicate deassert delay	18.3.1.4	7 BT max.	HFC: M	N/A [ ] M: Yes [ ]
CP4	CI circuit with no collision, SQE Test, or jabber	18.3.1.4	IDL signal	HFC: M	N/A [ ] M: Yes [ ]
CP5	DI circuit source switch delay from CS0 assert	18.3.1.4	9 BT max.	HFC: M	N/A [ ] M: Yes [ ]
CP6	DI circuit source switch delay from CS0 deassert	18.3.1.4	7 BT max.	HFC: M	N/A [ ] M: Yes [ ]

**18.5.6.13 signal\_quality\_error Message (SQE) Test function**

Item	Feature	Subclause	Value/Comment	Status	Support
STF1	SQE Test induced OTD or DI circuit signals	18.3.1.5	No extraneous signals permitted	HDS: M	N/A [ ] M: Yes [ ]
STF2	SQE_test_wait timer range	18.3.1.5	0.6 to 1.6 $\mu$ s	HDS: M	N/A [ ] M: Yes [ ]
STF3	SQE_test timer range	18.3.1.5	5 to 15 BT	HDS: M	N/A [ ] M: Yes [ ]
STF4	CI circuit during SQE Test	18.3.1.5	CS0 signal	HDS: M	N/A [ ] M: Yes [ ]
STF5	SQE Test in Link Fail states	18.3.1.5	CS0 must not be sent	HDS: M	N/A [ ] M: Yes [ ]

**18.5.6.14 Jabber function**

Item	Feature	Subclause	Value/Comment	Status	Support
JAB1	Jabber function implementation	18.3.1.6	Self-interrupt of transmit and loopback.	M	Yes [ ]
JAB2	Xmit_max. timer range	18.3.1.6	20 ms min., 150 ms max.	M	Yes [ ]
JAB3	CI circuit during jabber	18.3.1.6	CS0 signal	HFC: M	N/A [ ] M: Yes [ ]
JAB4	Unjab timer range	18.3.1.6	0.5 s $\pm$ 0.25 s	M	Yes [ ]
JAB5	MAU Jabber Lockup Protection	18.3.1.6	Jabber not activated by the longest permitted output specified in 9.6.5	M	Yes [ ]

### 18.5.6.15 Link Integrity Test function

Item	Feature	Subclause	Value/Comment	Status	Support
L11	Low light detected	18.3.1.7	ORD optical power does not support a BER of $10^{-10}$ for a duration of 2000 BT, or ORD optical power is $< -30$ dBm for 2000 BT and does not support a BER of $10^{-10}$ for a duration of 500 BT	M	Yes [ ]
L12	Low light not detected	18.3.1.7	ORD optical power exceeds $-32.5$ dBm or low light condition remains $< 30$ BT	M	Yes [ ]
L13 L14 L15	Signals during detected failure OTD circuit DI circuit CI circuit	18.3.1.7	OPT_IDL IDL IDL (except when jabber condition is also present)	M M M	Yes [ ] Yes [ ] Yes [ ]
L16	Link Test Fail state exit conditions	18.3.1.7	ORD optical power exceeds $-32.5$ dBm for $0.5$ s $\pm 0.25$ s	M	Yes [ ]
L17 L18 L19 L110 L111	Link fail effect on MAU functions Transmit Receive Loopback Collision Presence SQE Test	18.3.1.7	Disable Disable Disable Disable Disable	M M M M M	Yes [ ] Yes [ ] Yes [ ] Yes [ ] Yes [ ]
L112	Link Test Fail Extend state exit condition	18.3.1.7	Deferred until ORD = idle and DO = idle	M	Yes [ ]
L113	Power-on state	18.3.1.7	Link Test Fail Low Light	O	Yes [ ] No [ ]
L114	Link status indicator	18.3.1.7	Color=green on=Link Test Pass	O	Yes [ ] No [ ]



**18.5.6.16 MAU state diagram requirements**

Item	Feature	Subclause	Value/Comment	Status	Support
SD1	Full duplex mode MAU Transmit and Receive functions state diagram	18.3.2	Meets requirements of Figure 18–1b)	FDX: M	N/A [ ] M: Yes [ ]
SD2	Half duplex Transmit, Receive, Loopback, and Collision Presence functions state diagrams	18.3.2	Meets requirements of Figure 18–1a)	HFC:M	N/A [ ] M: Yes [ ]
SD3	<i>signal_quality_error</i> Message Test function state diagram	18.3.2	Meets requirements of Figure 18–2	HDS: M	N/A [ ] M: Yes [ ]
SD4	Jabber function state diagram	18.3.2	Meets requirements of Figure 18–3	M	Yes [ ]
SD5	Link Integrity Test function state diagram	18.3.2	Meets requirements of Figure 18–4	M	Yes [ ]

**18.5.6.17 MAU-to-AUI signal characteristics**

Item	Feature	Subclause	Value/Comment	Status	Support
ASC1	Signaling rate (stated on label)	7.3.2	10 Mb/s	AUI: M	N/A [ ] M: Yes [ ]
ASC2	CS0 signal frequency (on CI)	7.3.1.2	10 MHz $\pm$ 15%	AUI: M	N/A [ ] M: Yes [ ]
ASC3	CS0 signal duty cycle	7.3.1.2	60:40 worst case	AUI: M	N/A [ ] M: Yes [ ]

### 18.5.6.18 MAU-to-AUI DI and CI driver characteristics

Item	Feature	Subclause	Value/Comment	Status	Support
ADC1 ADC2	Differential output voltage Idle state Start of idle	7.4.1.1	$\leq 40$ mV after 80 BT Figure 7–12	AUI: M	N/A [ ] M: Yes [ ]
ADC3	Current into test load while idle	7.4.1.1	4 mA max. after 80 BT	AUI: M	N/A [ ] M: Yes [ ]
ADC4	Requirements after idle	7.4.1.2	1st bit to Figure 7–11	AUI: M	N/A [ ] M: Yes [ ]
ADC5	Common-mode output voltage, ac	7.4.1.3	$\leq 2.5$ V peak for 30 Hz to 40 kHz, $\leq 160$ mV peak for 40 kHz to 10 MHz, Figure 7–13	AUI: M	N/A [ ] M: Yes [ ]
ADC6	Differential output volt- age, open circuit	7.4.1.4	13 V peak max.	AUI: M	N/A [ ] M: Yes [ ]
ADC7	Common-mode output voltage, dc	7.4.1.5	$\leq 5.5$ V, Figure 7–13	AUI: M	N/A [ ] M: Yes [ ]
ADC8	Fault tolerance	7.4.1.6	Figure 7–14	AUI: M	N/A [ ] M: Yes [ ]
ADC9	Fault current	7.4.1.6	$\leq 150$ mA, any state, Figure 7–14	AUI: M	N/A [ ] M: Yes [ ]

### 18.5.6.19 AUI-to-MAU DO receiver characteristics

Item	Feature	Subclause	Value/Comment	Status	Support
DO1	Unsquelled threshold	7.4.2.1	160 mV max. differential	AUI: M	N/A [ ] M: Yes [ ]
DO2	Squelch	15.5.1	Reject signals $< \pm 160$ mV differential	AUI: M	N/A [ ] M: Yes [ ]
DO3	High to idle transition	7.4.1.1	Must not cause output	AUI: M	N/A [ ] M: Yes [ ]
DO4	Differential input impedance	7.4.2.2	Real part: $77.83 \Omega \pm 6\%$ , $0 \leq$ phase angle $\leq$ real part * 0.0338	AUI: M	N/A [ ] M: Yes [ ]
DO5	Common-mode range, ac	7.4.2.3	3 V min. for 30 Hz to 40 kHz, 200 mV min. for 40 kHz to 10 MHz	AUI: M	N/A [ ] M: Yes [ ]
DO6	Total common-mode range	7.4.2.4	Magnitude of 0 to 5.5 V ac+dc	AUI: M	N/A [ ] M: Yes [ ]
DO7	Common-mode current limit	7.4.2.4	$\leq 1$ mA	AUI: M	N/A [ ] M: Yes [ ]
DO8	IDL detection	7.3.1.1	$\leq 1.6$ BT	AUI: M	N/A [ ] M: Yes [ ]
DO9	Requirements after idle	7.4.2.5	Receiver in specification after start-up delay	AUI: M	N/A [ ] M: Yes [ ]
DO10	Receiver fault tolerance	7.4.2.6	Figure 7–16	AUI: M	N/A [ ] M: Yes [ ]
DO11	Input fault current	7.4.2.6	3 mA max. for Figure 7–16	AUI: M	N/A [ ] M: Yes [ ]

**18.5.6.20 AUI circuit termination**

Item	Feature	Subclause	Value/Comment	Status	Support
ACT1	Common-mode termination	7.5.2.6	If used, must be to VC	AUI: M	N/A [ ] M: Yes [ ]
ACT2	Pins 1, 4, 8, 11, 14 impedance to VC circuit	7.5.2.8	$\leq 5 \Omega$ at 5 MHz	AUI: M	N/A [ ] M: Yes [ ]
ACT3	Pins 1, 4, 8, 11, 14 coupling to VC circuit	7.5.2.8	Capacitive	AUI: M	N/A [ ] M: Yes [ ]

**18.5.6.21 MAU-to-AUI mechanical connections**

Item	Feature	Subclause	Value/Comment	Status	Support	
AM1	D-type connector dimensions	7.6.2	IEC 60807-2:1992 15-pole male	AUI: M	N/A [ ] M: Yes [ ]	
AM2	Shell plating material	7.6.2	Conductive	AUI: M	N/A [ ] M: Yes [ ]	
AM3	Shell multiple contact points	7.6.2	Number not defined (recommended)	AUI: M	N/A [ ] M: Yes [ ]	
AM4	Shell life expectancy	7.6.2	$\leq 5 \text{ m}\Omega$ after 500 matings	AUI: M	N/A [ ] M: Yes [ ]	
AM5	Locking posts and mounting	7.6.1	Figures 7–18 and 7–20	AUI: M	N/A [ ] M: Yes [ ]	
AM6	Pin connections	7.6.3	Circuit			
AM7			3	Data Out A	AUI: M	N/A [ ] M: Yes [ ]
AM8			10	Data Out B	AUI: M	N/A [ ] M: Yes [ ]
AM9			11	Capacitor to VC	AUI: M	N/A [ ] M: Yes [ ]
AM10			5	Data In A	AUI: M	N/A [ ] M: Yes [ ]
AM11			12	Data In B	AUI: M	N/A [ ] M: Yes [ ]
AM12			4	Capacitor to VC	AUI: M	N/A [ ] M: Yes [ ]
AM13			7	No connection	AUI: M	N/A [ ] M: Yes [ ]
AM14			15	No connection	AUI: M	N/A [ ] M: Yes [ ]
AM15			8	Capacitor to VC	AUI: M	N/A [ ] M: Yes [ ]
AM16			2	Control In A	AUI: M	N/A [ ] M: Yes [ ]
AM17			9	Control In B	AUI: M	N/A [ ] M: Yes [ ]
AM18			1	Capacitor to VC	AUI: M	N/A [ ] M: Yes [ ]
AM19			6	Voltage common	AUI: M	N/A [ ] M: Yes [ ]
AM20	13	Voltage plus	AUI: M	N/A [ ] M: Yes [ ]		
AM21	1	Capacitor to VC	AUI: M	N/A [ ] M: Yes [ ]		
	Shell		Isolated from all pins	AUI: M	N/A [ ] M: Yes [ ]	

**18.5.6.22 MAU reliability**

Item	Feature	Subclause	Value/Comment	Status	Support
MR1	Mean Time Before Failure	15.4	$> 10^7$ hours without causing communications failure among other stations	M	Yes [ ]

### 18.5.6.23 Power consumption

Item	Feature	Subclause	Value/Comment	Status	Support
PC1	Power surge limitation	15.5.3	$< 2 \times 10^{-3}$ A-s	APW: M	N/A [ ] M: Yes [ ]
PC2	Power surge duration	15.5.3	100 ms max.	APW: M	N/A [ ] M: Yes [ ]
PC3	Steady-state current drawn power-up capability:	15.5.3	$\leq 0.5$ A	APW: M	N/A [ ] M: Yes [ ]
PC4	Current-limited sources	15.5.3	0.5 A limited	APW: M	N/A [ ] M: Yes [ ]
PC5	Voltage-limited sources	7.5.2.5	11.28 to 15.75 V via any AUI cable	APW: M	N/A [ ] M: Yes [ ]
PC6	Labeling	15.5.3	As in 15.5.3	APW: M	N/A [ ] M: Yes [ ]
PC7	Power cycle behavior	15.5.3	No extraneous signals on MDI, DI, or CI	AUI: M	N/A [ ] M: Yes [ ]
PC8	Low VP behavior	7.5.2.5	No disruption of media	APW: M	N/A [ ] M: Yes [ ]
PC9	Power sourced on pin 13 of AUI	15.5.3	None if separate power source is implemented	SPW: X	N/A [ ] X: Yes [ ]
PC10	Optional power source isolation	15.5.3	If implemented, shall withstand one of 15.3.4 tests	SPW: M	N/A [ ] M: Yes [ ]

### 18.5.6.24 PLS–PMA requirements

Item	Feature	Subclause	Value/Comment	Status	Support
PMA1	Messages between PLS in DTE or Repeater and PMA	15.5.4	As in 7.2.1	M	Yes [ ]

### 18.5.6.25 *signal\_quality\_error* message (SQE)

Item	Feature	Subclause	Value/Comment	Status	Support
SQE1	Local MAU transmitting and no collision or fault detected	15.5.4.2.1	<i>MAU_available</i> sent on CI	M	Yes [ ]
SQE2	Whenever a collision exists as described in 18.3.1.4	15.5.4.2.1	SQE sent	HFC: M	N/A [ ] M: Yes [ ]
SQE3	SQE Test as described in 18.3.1.5	15.5.4.2.1	SQE sent	HDS:M RPT: X	N/A [ ] M: Yes [ ] N/A [ ] X: Yes [ ]
SQE4	Jabber Condition exists as described in 18.3.1.6	15.5.4.2.1	SQE sent	HFC:M	N/A [ ] M: Yes [ ]
SQE5	Message sent in the absence of SQE	15.5.4.2.1	<i>MAU_available</i> message	M	Yes [ ]

**18.5.6.26 Environmental requirements**

Item	Feature	Subclause	Value/Comment	Status	Support
E1	Ambient Plane Wave field in which MAU meets specification	15.6.2	2 V/m from 10 kHz to 30 MHz. 5 V/m from 30 MHz to 1 GHz.	M	Yes [ ]
E2	Electromagnetic Emissions and Susceptibility	15.6.2	Comply with local and/or national requirements. If none exist, comply with CISPR 22: 1993.	M	Yes [ ]

**18.5.6.27 MAU labeling**

Item	Feature	Subclause	Value/Comment	Status	Support
LBL1	MAU type	15.7	10BASE-FL	O	Yes [ ] No [ ]
LBL2	Data rate	15.7	10 Mb/s	O	Yes [ ] No [ ]
LBL3	Power level	15.7	Maximum current drain	O	Yes [ ] No [ ]
LBL4	Safety warnings	15.7	Any applicable	O	Yes [ ] No [ ]
LBL5	Port labeling	15.7	Input and output	O	Yes [ ] No [ ]
LBL6	Full duplex mode	15.7	Full duplex capable	FDX: O	N/A [ ] Yes [ ] No [ ]



## 19. Layer Management for 10 Mb/s baseband repeaters

Clause 19 is deprecated by Clause 30.

### 19.1 Introduction

The Repeater Management specification has been developed in accordance with the OSI management architecture as specified in ISO/IEC 7498-4: 1989 and the specific requirements of IEEE Std 802.1F-1993. Implementation of this clause is not a requirement for conformance to Clause 9.

#### 19.1.1 Scope

This clause defines a set of mechanisms that enable management of ISO/IEC 8802-3 10 Mb/s baseband repeater units. The managed objects within this International Standard are defined in terms of their behaviour, attributes, actions, notifications, and packages in accordance with IEEE 802.1 and ISO/IEC International Standards for network management. Managed objects are grouped into mandatory and optional packages.

This International Standard is defined to be independent of any particular management application or management protocol. The means by which the managed objects defined in this International Standard are accessed is beyond the scope of this International Standard.

#### 19.1.2 Relationship to objects in IEEE Std 802.1F-1993

The following managed object classes, if supported by an implementation, shall be as specified in IEEE Std 802.1F-1993: oResourceTypeID, oEWMAMetricMonitor:

- a) **oResourceTypeID.** This object class is mandatory and shall be implemented as defined in IEEE Std 802.1F-1993. This object is bound to repeater as defined by the NAMEBINDING in 19.2.4 and H.2.2.1.
- b) **oEWMAMetricMonitor.** This object class is optional. When implemented, it shall be implemented as defined in IEEE Std 802.1F-1993, subject to the specific requirements described below. This object is bound to system as defined by the NAMEBINDING in H.2.2.1.

Implementations of Repeater Management that support the oEWMAMetricMonitor managed object class are required to support values of aGranularityPeriod as small as one second. Implementations are required to support at least one sequence of low and high thresholds. The granularity period may be set to equal to the moving time period as a minimal conformant implementation.

#### 19.1.3 Definitions

See 1.4.

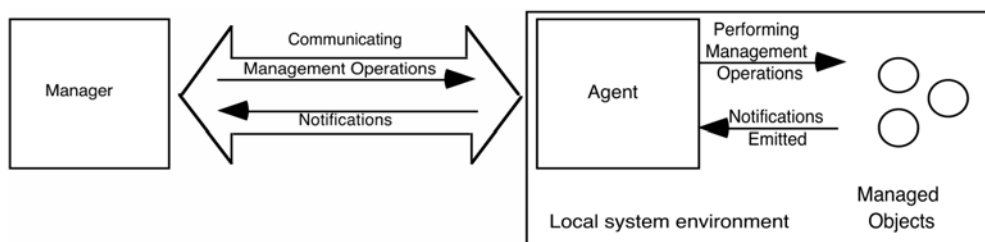
#### 19.1.4 Symbols and abbreviations

See 1.5.

### 19.1.5 Management model

This International Standard describes management of repeaters in terms of a general model of management of resources within the open systems environment. The model is described in ISO/IEC 10040: 1992, a brief summary of the model is included here.

Management is viewed as a distributed application modeled as a set of interacting management processes. These processes are executed by systems within the open environment. A managing system executes a managing process that invokes management operations. A managed system executes a process that is receptive to these management operations and provides an interface to the resources to be managed. A managed object is the abstraction of a resource that represents its properties as seen by (and for the purpose of) management. Managed objects respond to a defined set of management operations. Managed objects are also capable of emitting a defined set of notifications. This interaction of processes is shown in Figure 19–1.



NOTE—Figure 1 of ISO/IEC 10040 has been reproduced with the permission of ISO. Copies of the complete standard may be obtained from the International Organization for Standardization, Case Postale 56, 1 rue de Varembe, CH-1211, Genève 20, Switzerland/Suisse.

**Figure 19–1—Interaction between manager, agent, and objects**

A managed object is a management view of a resource. The resource may be a logical construct, function, physical device, or anything subject to management. Managed objects are defined in terms of four types of elements:

- Attributes.* Data-like properties (as seen by management) of a managed object.
- Actions.* Operations that a managing process may perform on an object or its attributes.
- Notifications.* Unsolicited reports of events that may be generated by an object.
- Behaviour.* The way in which managed objects, attributes, and actions interact with the actual resources they model and with each other.

The above items are defined in 19.2.3 through 19.2.6 of this International Standard in terms of the template requirements of ISO/IEC 10165-4: 1992 in Annex H.

Some of the functions and resources within a repeater are appropriate targets for management. They have been identified by specifying managed objects that provide a management view of the functions or resources. Within this general model, a repeater is viewed as a managed device. It performs functions as defined by the applicable standard for such a device. Managed objects providing a view of those functions and resources appropriate to the management of a repeater are specified. The purpose of this International Standard is to define the object classes associated with repeaters in terms of their attributes, operations, notifications, and behaviour.



## 19.2 Managed objects

### 19.2.1 Introduction

This document defines the management of IEEE 802.3 repeaters by defining associated managed objects. This management encompasses two distinct aspects of repeater management.

The first aspect provides the means to monitor and control the functions of a repeater. These functions include, but are not limited to, identifying a repeater, testing and initializing a repeater, and enabling/disabling a port.

The second aspect provides the means to monitor traffic from attached segments, and to measure traffic sourced by DTEs connected to these segments. This is done by gathering statistics on packets that enter a repeater and maintaining those statistics on a per-port basis.

### 19.2.2 Overview of managed objects

Managed objects provide a means to

- a) Identify a resource
- b) Control a resource
- c) Monitor a resource

#### 19.2.2.1 Text description of managed objects

In case of conflict, the formal behaviour definitions in 19.2.3 through 19.2.6 take precedence over the text descriptions in this subclause.

- a) **repeater.** The topmost managed object class of that portion of the containment tree shown in Figure 19–3. All other managed objects and their attributes defined in this clause are contained within the repeater managed object.
- b) **repeaterMonitor.** A managed object class called out by IEEE Std 802.1F-1993.
- c) **resourceTypeID.** A managed object class called out by IEEE Std 802.1F-1993.
- d) **group.** The group managed object class is a view of a collection of ports.
- e) **port.** The port managed object class provides a view of the functional link between the data transfer service and a single PMA. The attributes associated with port deal with the monitoring of traffic being handled by the repeater from the port and control of the operation of the port. The port enable/disable function as reported by portAdminState is preserved across events involving loss of power.

NOTE—Attachment to nonstandard PMAs is outside the scope of this International Standard.

#### 19.2.2.2 Port functions to support management

The port object class contains seven functions that are used to collect statistics on the activity received by the port. The relationship of the functions to the port and to the port attributes is shown in Figure 19–2.

- a) **Activity Timing function.** Measures the duration of the assertion of the CarrierEvent signal. This duration value must be adjusted by removing the value of Carrier Recovery Time (see 9.5.6.5) to obtain the true duration of activity on the network. The output of the Activity Timing function is the ActivityDuration value, which represents the duration of the CarrierEvent signal as expressed in units of bit times.
- b) **Carrier Event function.** Asserts the CarrierEvent signal when the repeater exits the IDLE state (see Figure 9–2) and the port has been determined to be port N. It de-asserts the CarrierEvent signal when, for a duration of at least Carrier Recovery Time (see 9.5.6.5), both the DataIn(N) variable has

- the value II and the CollIn(N) variable has the value -SQE. The value N is the port assigned at the time of transition from the IDLE state.
- c) **Collision Event function.** Asserts the CollisionEvent signal when the CollIn(X) variable has the value SQE. The CollisionEvent signal remains asserted until the assertion of any CarrierEvent signal due to the reception of the following event.
  - d) **Cyclic Redundancy Check function.** Verifies that the sequence of octets output by the framing function contains a valid frame check sequence field. The frame check sequence field is the last four octets received from the output of the framing function. The algorithm for generating an FCS from the octet stream is specified in 3.2.9. If the FCS generated according to this algorithm is not the same as the last four octets received from the framing function, then the FCSError signal is asserted. The FCSError signal is cleared upon the assertion of the CarrierEvent signal due to the reception of the following event.
  - e) **Framing function.** Recognizes the boundaries of an incoming frame by monitoring the CarrierEvent signal and the decoded data stream. Data bits are accepted while the CarrierEvent signal is asserted. The framing function strips preamble and start of frame delimiter from the received data stream. The remaining bits are aligned along octet boundaries. If there is not an integral number of octets, then FramingError shall be asserted. The FramingError signal is cleared upon the assertion of the CarrierEvent signal due to the reception of the following event.
  - f) **Octet Counting function.** Counts the number of complete octets received from the output of the framing function. The output of the octet counting function is the OctetCount value. The OctetCount value is reset to zero upon the assertion of the CarrierEvent signal due to the reception of the following event.
  - g) **Source Address function.** Extracts octets from the stream output by the framing function. The seventh through twelfth octets shall be extracted from the octet stream and output as the SourceAddress variable. The SourceAddress variable is set to an invalid state upon the assertion of the CarrierEvent signal due to the reception of the following event.

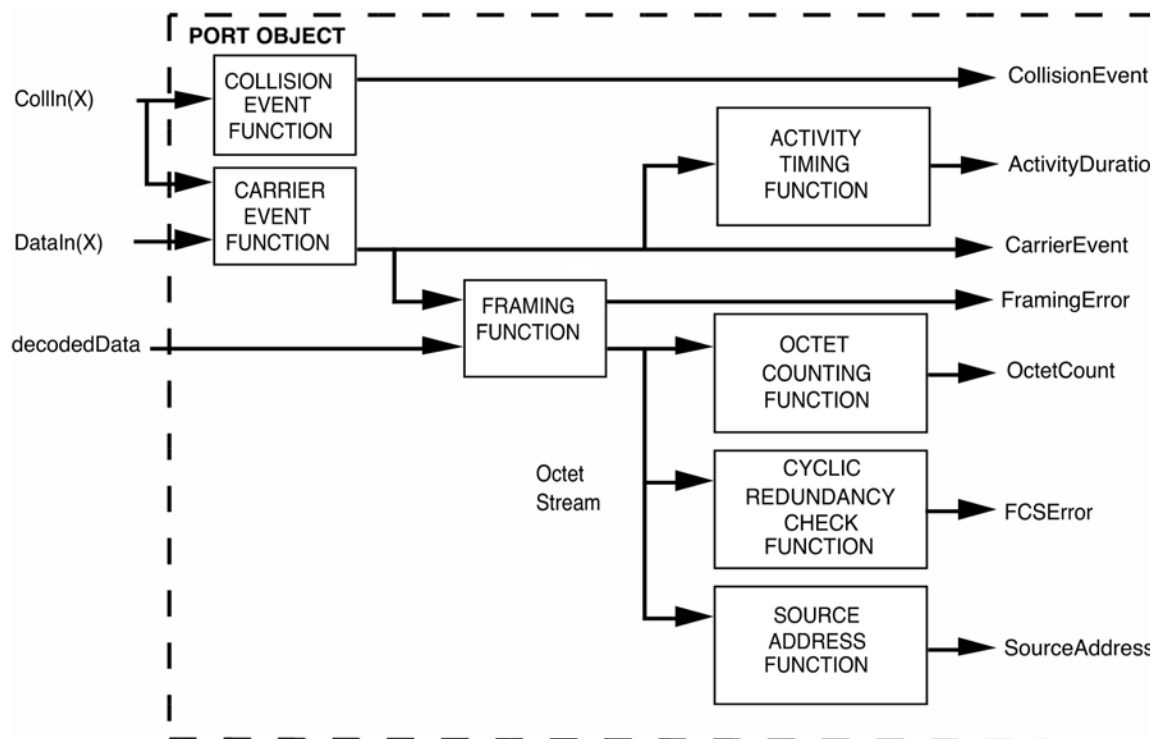


Figure 19-2—Functions relationship

### 19.2.2.3 Containment

A containment relationship is a structuring relationship for managed objects in which the existence of a managed object is dependent on the existence of a containing managed object. The contained managed object is said to be the subordinate managed object and the containing managed object the superior managed object. The containment relationship is used for naming managed objects. The local containment relationships among object classes are depicted in Figure 19–3. This figure also shows the names, naming attributes, and data attributes of the object classes as well as whether a particular containment relationship is one-to-one or one-to-many. For further requirements on this topic, see IEEE Std 802.1F-1993.

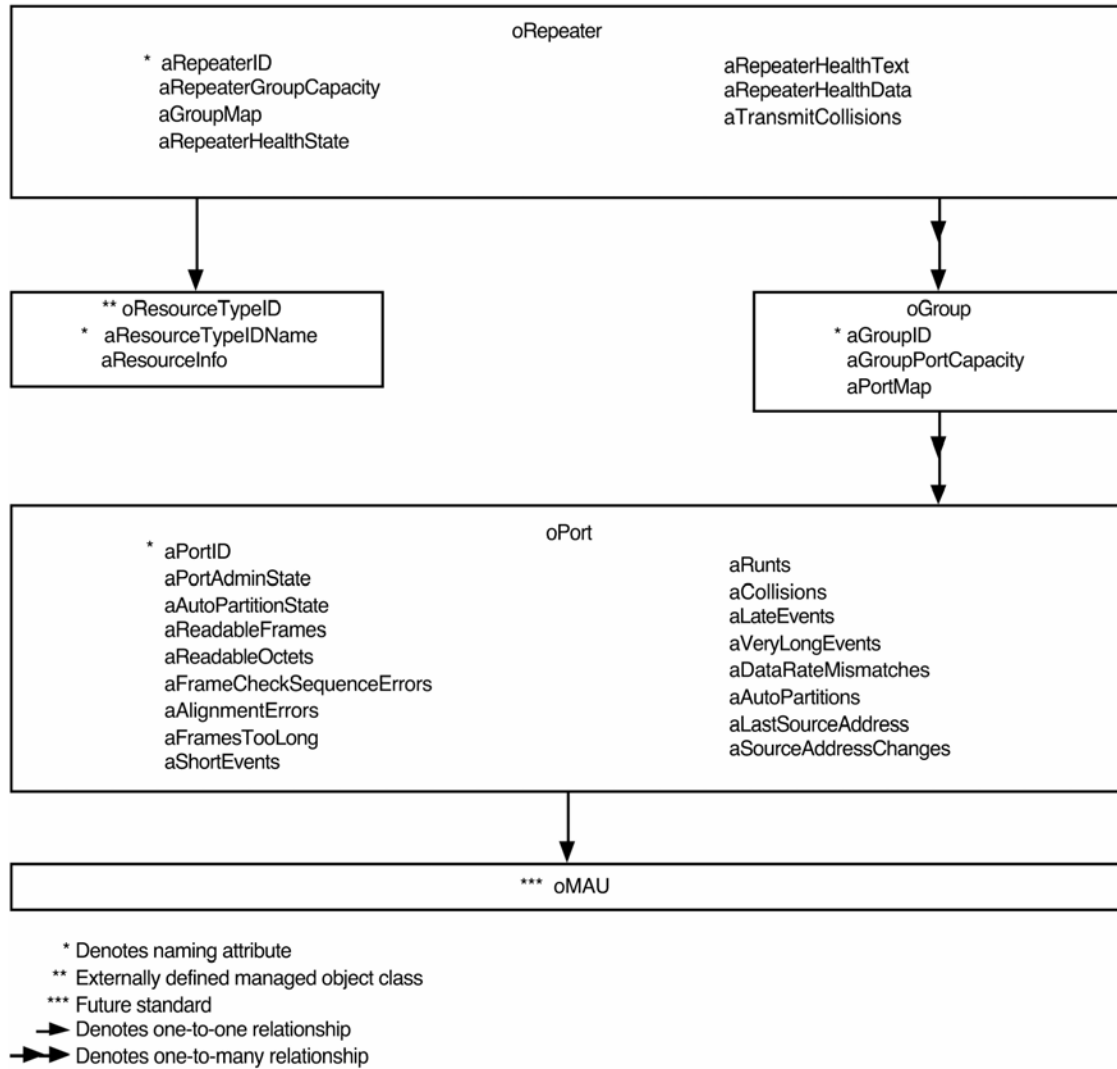


Figure 19–3—Entity relationship diagram

#### **19.2.2.4 Naming**

The name of an individual managed object is hierarchically defined within a managed system. For example, a port might be identified as “repeater 3, group 01, port 13,” that is, port 13 of group 01 of a repeater with repeaterID 3 within the managed system. This is represented in the relationship of the naming attributes in Figure 19–3.

#### **19.2.2.5 Packages and capabilities**

This International Standard makes use of the concept of “packages” as defined in ISO/IEC 10165-4: 1992 as a means of grouping behaviour, attributes, actions, and notifications within a managed object class definition. Packages may either be mandatory or conditional, that is to say, present if a given condition is true. Within this International Standard, “capabilities” are defined, each of which corresponds to a set of packages, which are components of a number of managed object class definitions and which share the same condition for presence. The “Basic Control Capability” consists of the set of mandatory packages. All other capabilities are optional and comprise sets of conditional packages. For a managed repeater to be conformant to this International Standard, it shall fully implement the Basic Control Capability. For the repeater to be conformant to an optional capability, it shall implement that entire capability. The capabilities and their associated packages are summarized in Table 19–1 (see facing page).

**Table 19–1—Packages and capabilities**

Address Tracking Capability (Optional) Performance Monitor Capability (Optional) Basic Control Capability (Mandatory)				
<b>oRepeater managed object class</b>				
aRepeaterID	ATTRIBUTE GET	X		
aRepeaterGroupCapacity	ATTRIBUTE GET	X		
aGroupMap	ATTRIBUTE GET	X		
aRepeaterHealthState	ATTRIBUTE GET	X		
aRepeaterHealthText	ATTRIBUTE GET	X		
aRepeaterHealthData	ATTRIBUTE GET	X		
aTransmitCollisions	ATTRIBUTE GET		X	
acResetRepeater	ACTION	X		
acExecuteNonDisruptiveSelfTest	ACTION	X		
nRepeaterHealth	NOTIFICATION	X		
nRepeaterReset	NOTIFICATION	X		
nGroupMapChange	NOTIFICATION	X		
<b>oResourceTypeID managed object class</b>				
aResourceTypeIDName	ATTRIBUTE GET	X		
aResourceInfo	ATTRIBUTE GET	X		
<b>oGroup managed object class</b>				
aGroupID	ATTRIBUTE GET	X		
aGroupPortCapacity	ATTRIBUTE GET	X		
aPortMap	ATTRIBUTE GET	X		
nPortMapChange	NOTIFICATION	X		
<b>oPort managed object class</b>				
aPortID	ATTRIBUTE GET	X		
aPortAdminState	ATTRIBUTE GET	X		
aAutoPartitionState	ATTRIBUTE GET	X		
aReadableFrames	ATTRIBUTE GET		X	
aReadableOctets	ATTRIBUTE GET		X	
aFrameCheckSequenceErrors	ATTRIBUTE GET		X	
aAlignmentErrors	ATTRIBUTE GET		X	
aFramesTooLong	ATTRIBUTE GET		X	
aShortEvents	ATTRIBUTE GET		X	
aRunts	ATTRIBUTE GET		X	
aCollisions	ATTRIBUTE GET		X	
aLateEvents	ATTRIBUTE GET		X	
aVeryLongEvents	ATTRIBUTE GET		X	
aDataRateMismatches	ATTRIBUTE GET		X	
aAutoPartitions	ATTRIBUTE GET		X	
aLastSourceAddress	ATTRIBUTE GET			X
aSourceAddressChanges	ATTRIBUTE GET			X
acPortAdminControl	ACTION	X		
<b>Common Attributes Template</b>				
aRMCounter	ATTRIBUTE GET		X	X

### 19.2.3 Repeater managed object class

This subclause formally defines the behaviours for Repeater managed object classes, attributes, actions, and notifications.

#### 19.2.3.1 Repeater attributes

##### 19.2.3.1.1 aRepeaterID

ATTRIBUTE  
APPROPRIATE SYNTAX  
INTEGER  
BEHAVIOUR DEFINED AS:

The value of aRepeaterID is assigned so as to uniquely identify a repeater among the subordinate managed objects of system (systemID and system are defined in ISO/IEC 10165-2: 1992).

##### 19.2.3.1.2 aRepeaterGroupCapacity

ATTRIBUTE  
APPROPRIATE SYNTAX  
INTEGER  
BEHAVIOUR DEFINED AS:

The aRepeaterGroupCapacity is the number of groups that can be contained within the repeater. Within each managed repeater, the groups are uniquely numbered in the range from 1 to aRepeaterGroupCapacity. Some groups may not be present in a given repeater instance, in which case the actual number of groups present is less than aRepeaterGroupCapacity. The number of groups present is never greater than aRepeaterGroupCapacity.

##### 19.2.3.1.3 aGroupMap

ATTRIBUTE  
APPROPRIATE SYNTAX  
BITSTRING  
BEHAVIOUR DEFINED AS:

A string of bits which reflects the current configuration of units which are viewed by group managed objects. The length of the bitstring is “aRepeaterGroupCapacity” bits. The first bit relates to group 1. A “1” in the bitstring indicates presence of the group, “0” represents absence of the group.

##### 19.2.3.1.4 aRepeaterHealthState

ATTRIBUTE  
APPROPRIATE SYNTAX:

An ENUMERATED VALUE LIST that has the following entries:

other	--undefined or unknown
ok	--no known failures
repeaterFailure	--known to have a repeater related failure
groupFailure	--known to have a group related failure
portFailure	--known to have a port related failure
generalFailure	--has a failure condition, unspecified type

**BEHAVIOUR DEFINED AS:**

The aRepeaterHealthState attribute indicates the operational state of the repeater. The aRepeaterHealthData and aRepeaterHealthText attributes may be consulted for more specific information about the state of the Repeater's health. In case of multiple kinds of failures (e.g., repeater failure and port failure), the value of this attribute shall reflect the highest priority in the following order:

repeater failure  
group failure  
port failure  
general failure.

**19.2.3.1.5 aRepeaterHealthText**

## ATTRIBUTE

## APPROPRIATE SYNTAX:

A PrintableString, 255 characters max.

## BEHAVIOUR DEFINED AS:

The aRepeaterHealthText attribute is a text string that provides information relevant to the operational state of the repeater. Repeater vendors may use this mechanism to provide detailed failure information or instructions for problem resolution. The contents are vendor specific.

**19.2.3.1.6 aRepeaterHealthData**

## ATTRIBUTE

## APPROPRIATE SYNTAX:

OCTET STRING, 0–255.

## BEHAVIOUR DEFINED AS:

The aRepeaterHealthData attribute is a block of data octets that provides information relevant to the operational state of the repeater. The encoding of this data block is vendor dependent. Repeater vendors may use this mechanism to provide detailed failure information or instructions for problem resolution.

**19.2.3.1.7 aTransmitCollisions**

## ATTRIBUTE

## APPROPRIATE SYNTAX:

Generalized non-resettable counter. This counter has a maximum increment rate of 75 000 counts per second.

## BEHAVIOUR DEFINED AS:

This counter is incremented every time the repeater state machine enters the TRANSMIT COLLISION state from any state other than ONE PORT LEFT (see Figure 9–2).

**19.2.3.2 Repeater actions****19.2.3.2.1 acResetRepeater**

## ACTION

## APPROPRIATE SYNTAX

None required

BEHAVIOUR DEFINED AS:

This is the transition to the START state of Figure 9–2 in Clause 9. The repeater performs a disruptive self-test that has the following characteristics:

- a) The components are not specified.
- b) The test resets the repeater but without affecting management information about the repeater.
- c) The test does not inject packets onto any segment.
- d) Packets received during the test may or may not be transferred.
- e) The test does not interfere with management functions.

This causes an nRepeaterReset notification to be sent.

### 19.2.3.2.2 acExecuteNonDisruptiveSelfTest

ACTION

APPROPRIATE SYNTAX

None required

BEHAVIOUR DEFINED AS:

The repeater performs a vendor-specific, non-disruptive self-test that has the following characteristics:

- a) The components are not specified.
- b) The test does not change the state of the repeater or management information about the repeater.
- c) The test does not inject packets onto any segment.
- d) The test does not prevent the transfer of any packets.
- e) Completion of the test causes an nRepeaterHealth to be sent.

### 19.2.3.3 Repeater notifications

#### 19.2.3.3.1 nRepeaterHealth

NOTIFICATION

APPROPRIATE SYNTAX

A SEQUENCE of 3 data types. The first is mandatory, the following two are optional. The first is value of the attribute aRepeaterHealthState. The second is the value of the attribute aRepeaterHealthText. The third is the value of the attribute aRepeaterHealthData.

BEHAVIOUR DEFINED AS:

This notification conveys information related to the operational state of the repeater. See the aRepeaterHealthState, aRepeaterHealthText, and aRepeaterHealthData attributes for descriptions of the information that is sent. The nRepeaterHealth notification is sent only when the health state of the repeater changes. The nRepeaterHealth notification shall contain repeaterHealthState. repeaterHealthData and repeaterHealthText may or may not be included. The nRepeaterHealth notification is not sent as a result of powering up a repeater.



**19.2.3.3.2 nRepeaterReset**

NOTIFICATION  
APPROPRIATE SYNTAX

A SEQUENCE of 3 data types. The first is mandatory, the following two are optional. The first is value of the attribute aRepeaterHealthState. The second is the value of the attribute aRepeaterHealthText. The third is the value of the attribute aRepeaterHealthData.

BEHAVIOUR DEFINED AS:

This notification conveys information related to the operational state of the repeater. The nRepeaterReset notification is sent when the repeater is reset as the result of a power-on condition or upon completion of the acResetRepeater action. The nRepeaterReset notification shall contain repeaterHealthState, repeaterHealthData and RepeaterHealthText may, or may not be included.

**19.2.3.3.3 nGroupMapChange**

NOTIFICATION  
APPROPRIATE SYNTAX  
BITSTRING

BEHAVIOUR DEFINED AS:

This notification is sent when a change occurs in the group structure of a repeater. This occurs only when a group is logically removed from or added to a repeater. The nGroupMapChange notification is not sent when powering up a repeater. The value of the notification is the updated value of the aGroupMap attribute.

**19.2.4 ResourceTypeID Managed Object Class**

Implementation of this managed object in accordance with the definition contained in IEEE Std 802.1F-1993 is a conformance requirement of this International Standard. A single instance of the Resource Type ID managed object exists within the Repeater managed object class. The managed object itself is contained in IEEE Std 802.1F-1993; therefore, only the name binding appears in this International Standard.

**19.2.5 Group managed object class**

This subclause formally defines the behaviours for Group managed object classes attributes and notification.

**19.2.5.1 Group attributes****19.2.5.1.1 aGroupID**

ATTRIBUTE  
APPROPRIATE SYNTAX  
INTEGER

BEHAVIOUR DEFINED AS:

A value unique within the repeater. This value is never greater than aRepeaterGroupCapacity.

### 19.2.5.1.2 aGroupPortCapacity

ATTRIBUTE  
APPROPRIATE SYNTAX  
INTEGER  
BEHAVIOUR DEFINED AS:

The aGroupPortCapacity is the number of ports contained within the group. Valid range is 1–1024. Within each group, the ports are uniquely numbered in the range from 1 to aGroupPortCapacity. Some ports may not be present in a given group instance, in which case the actual number of ports present is less than aGroupPortCapacity. The number of ports present is never greater than aGroupPortCapacity.

### 19.2.5.1.3 aPortMap

ATTRIBUTE  
APPROPRIATE SYNTAX  
BitString  
BEHAVIOUR DEFINED AS:

A string of bits which reflects the current configuration of port managed objects within this group. The length of the bitstring is “aGroupPortCapacity” bits. The first bit relates to group 1. A “1” in the bitstring indicates presence of the port, “0” represents absence of the port.

## 19.2.5.2 Group Notifications

### 19.2.5.2.1 nPortMapChange

NOTIFICATION  
APPROPRIATE SYNTAX  
BitString  
BEHAVIOUR DEFINED AS:

This notification is sent when a change occurs in the port structure of a group. This occurs only when a port is logically removed from or added to a group. The nPortMapChange notification is not sent when powering up a repeater. The value of the notification is the updated value of the aPortMap attribute.

## 19.2.6 Port managed object class

This subclause formally defines the behaviours for Port managed object classes attributes and action.

### 19.2.6.1 Port Attributes

#### 19.2.6.1.1 aPortID

ATTRIBUTE  
APPROPRIATE SYNTAX  
INTEGER  
BEHAVIOUR DEFINED AS:

A value unique in the group. It is assumed that ports are partitioned into groups that also have IDs. This value can never be greater than aGroupPortCapacity.

**19.2.6.1.2 aPortAdminState**

ATTRIBUTE

APPROPRIATE SYNTAX:

An ENUMERATED VALUE LIST that has the following entries.

disabled

enabled

BEHAVIOUR DEFINED AS:

A disabled port neither transmits nor receives. The port shall be explicitly enabled to restore operation. The acPortAdminControl action provides this ability. The port enable/disable function as reported by this attribute is preserved across repeater reset including loss of power.

aPortAdminState takes precedence over auto-partition and functionally operates between the auto-partition mechanism and the AUI/PMA. Auto-partition is reinitialized whenever acPortAdminControl is enabled.

**19.2.6.1.3 aAutoPartitionState**

ATTRIBUTE

APPROPRIATE SYNTAX:

An ENUMERATED VALUE LIST that has the following entries.

autoPartitioned

notAutoPartitioned

BEHAVIOUR DEFINED AS:

The aAutoPartitionState flag indicates whether the port is currently partitioned by the repeater's auto-partition protection. The conditions that cause port partitioning are specified in partition state machine in Clause 9. They are not differentiated here.

**19.2.6.1.4 aReadableFrames**

ATTRIBUTE

APPROPRIATE SYNTAX:

Generalized non-resettable counter. This counter has a maximum increment rate of 15 000 counts per second.

BEHAVIOUR DEFINED AS:

A representation of the total frames of valid frame length. Increment counter by one for each frame whose OctetCount is greater than or equal to minFrameSize and less than or equal to maxFrameSize (see 4.4.2) and for which the FCSError and CollisionEvent signals are not asserted.

NOTE—This statistic provides one of the parameters necessary for obtaining the packet error rate.

**19.2.6.1.5 aReadableOctets**

ATTRIBUTE

APPROPRIATE SYNTAX:

Generalized non-resettable counter. This counter has a maximum increment rate of 1 240 000 counts per second.

BEHAVIOUR DEFINED AS:

Increment counter by OctetCount for each frame which has been determined to be a readable frame.

NOTE—This statistic provides an indicator of the total data transferred.

#### 19.2.6.1.6 aFrameCheckSequenceErrors

ATTRIBUTE

APPROPRIATE SYNTAX:

Generalized non-resettable counter. This counter has a maximum increment rate of 15 000 counts per second.

BEHAVIOUR DEFINED AS:

Increment counter by one for each frame with the FCSError signal asserted and the FramingError and CollisionEvent signals deasserted and whose OctetCount is greater than or equal to minFrameSize and less than or equal to maxFrameSize (see 4.4.2).

#### 19.2.6.1.7 aAlignmentErrors

ATTRIBUTE

APPROPRIATE SYNTAX:

Generalized non-resettable counter. This counter has a maximum increment rate of 15 000 counts per second.

BEHAVIOUR DEFINED AS:

Increment counter by one for each frame with the FCSError and FramingError signals asserted and CollisionEvent signal deasserted and whose OctetCount is greater than or equal to minFrameSize and less than or equal to maxFrameSize (see 4.4.2). If aAlignmentErrors is incremented then the aFrameCheckSequenceErrors attribute shall not be incremented for the same frame.

#### 19.2.6.1.8 aFramesTooLong

ATTRIBUTE

APPROPRIATE SYNTAX:

Generalized non-resettable counter. This counter has a maximum increment rate of 815 counts per second.

BEHAVIOUR DEFINED AS:

Increment counter by one for each frame whose OctetCount is greater than maxFrameSize (see 4.4.2). If aFrameTooLong is counted then neither the aAlignmentErrors nor the aFrameCheckSequenceErrors attribute shall be incremented for the frame.

#### 19.2.6.1.9 aShortEvents

ATTRIBUTE

APPROPRIATE SYNTAX:

Generalized non-resettable counter. This counter has a maximum increment rate of 75 000 counts per second.

BEHAVIOUR DEFINED AS:

Increment counter by one for each CarrierEvent with ActivityDuration less than ShortEventMaxTime. ShortEventMaxTime is greater than 74 bit times and less than 82 bit times. ShortEventMaxTime has tolerances included to provide for circuit losses between a conformance test point at the AUI and the measurement point within the state machine.

NOTE—shortEvents may indicate externally generated noise hits which will cause the repeater to transmit Runts to its other ports, or propagate a collision (which may be late) back to the transmitting DTE and damaged frames to the rest of the network.

Implementors may wish to consider selecting the ShortEventMaxTime towards the lower end of the allowed tolerance range to accommodate bit losses suffered through physical channel devices not budgeted for within this International Standard.

#### 19.2.6.1.10 aRunts

ATTRIBUTE

APPROPRIATE SYNTAX:

Generalized non-resettable counter. This counter has a maximum increment rate of 75 000 counts per second.

BEHAVIOUR DEFINED AS:

Increment counter by one for each CarrierEvent that meets one of the following two conditions. Only one test need be made. (1) The ActivityDuration is greater than ShortEventMaxTime and less than ValidPacketMinTime and the CollisionEvent signal is deasserted. (2) The OctetCount is less than 64, the ActivityDuration is greater than ShortEventMaxTime and the CollisionEvent signal is deasserted. ValidPacketMinTime is greater than or equal to 552 bit times and less than 565 bit times. An event whose length is greater than 74 bit times but less than 82 bit times shall increment either the aShortEvents attribute or the aRunts attribute but not both. A CarrierEvent greater than or equal to 552 bit times but less than 565 bit times may or may not be counted as a runt. ValidPacketMinTime has tolerances included to provide for circuit losses between a conformance test point at the AUI and the measurement point within the state machine.

NOTE—Runts usually indicate collision fragments, a normal network event. In certain situations associated with large diameter networks a percentage of runts may exceed ValidPacketMinTime.

#### 19.2.6.1.11 aCollisions

ATTRIBUTE

APPROPRIATE SYNTAX:

Generalized non-resettable counter. This counter has a maximum increment rate of 75 000 counts per second.

BEHAVIOUR DEFINED AS:

Increment counter by one for each CarrierEvent in which the CollisionEvent signal is asserted.  
Increment counter by one for any CarrierEvent signal on any port in which the CollisionEvent signal on this port is asserted.

#### 19.2.6.1.12 aLateEvents

ATTRIBUTE

APPROPRIATE SYNTAX:

Generalized non-resettable counter. This counter has a maximum increment rate of 75 000 counts per second.

BEHAVIOUR DEFINED AS:

Increment counter by one for each CarrierEvent in which the CollIn(X) variable transitions to the value SQE (see 9.9.6.2) while the ActivityDuration is greater than the LateEventThreshold. Such a CarrierEvent is counted twice, as both a aCollision and as a aLateEvent. The LateEventThreshold is greater than 480 bit times and less than 565 bit times. LateEventThreshold has tolerances included to permit an

implementation to build a single threshold to serve as both the LateEventThreshold and ValidPacketMinTime threshold.

#### 19.2.6.1.13 aVeryLongEvents

ATTRIBUTE

APPROPRIATE SYNTAX:

Generalized non-resettable counter. This counter has a maximum increment rate of 250 counts per second.

BEHAVIOUR DEFINED AS:

Increment counter by one for each CarrierEvent whose ActivityDuration is greater than the MAU Jabber Lockup Protection timer TW3 (see 9.6.1, 9.6.5). Other counters may be incremented as appropriate.

#### 19.2.6.1.14 aDataRateMismatches

ATTRIBUTE

APPROPRIATE SYNTAX:

Generalized non-resettable counter.

BEHAVIOUR DEFINED AS:

Increment counter by one for each frame received by this port that meets all of the conditions required by only one of the following two measurement methods: Measurement method A: 1) The CollisionEvent signal is not asserted. 2) The ActivityDuration is greater than ValidPacketMinTime. 3) The frequency (data rate) is detectably mismatched from the local transmit frequency. Measurement method B: 1) The CollisionEvent signal is not asserted. 2) The OctetCount is greater than 63. 3) The frequency (data rate) is detectably mismatched from the local transmit frequency. The exact degree of mismatch is vendor specific and is to be defined by the vendor for conformance testing.

When this event occurs, other counters whose increment conditions were satisfied may or may not also be incremented, at the implementor's discretion.

NOTE—Whether or not the repeater was able to maintain data integrity is beyond the scope of this International Standard.

#### 19.2.6.1.15 aAutoPartitions

ATTRIBUTE

APPROPRIATE SYNTAX:

Generalized non-resettable counter.

BEHAVIOUR DEFINED AS:

Increment counter by one for each time that the repeater has automatically partitioned this port. The conditions that cause port partitioning are specified in the partition state machine in Clause 9. They are not differentiated here.

#### 19.2.6.1.16 aLastSourceAddress

ATTRIBUTE

APPROPRIATE SYNTAX:

MACAddress

BEHAVIOUR DEFINED AS:

The `aLastSourceAddress` attribute is the Source Address of the last readableFrame received by this port.

#### 19.2.6.1.17 `aSourceAddressChanges`

ATTRIBUTE

APPROPRIATE SYNTAX:

Generalized non-resettable counter. This counter has a maximum increment rate of 15 000 counts per second.

BEHAVIOUR DEFINED AS:

Increment counter by one each time that the `aLastSourceAddress` attribute has changed.

NOTE—This may indicate whether a link is connected to a single DTE or another multiuser segment.

#### 19.2.6.2 Port Actions

##### 19.2.6.2.1 `acPortAdminControl`

ACTION

APPROPRIATE SYNTAX:

Same as `aPortAdminState`.

BEHAVIOUR DEFINED AS:

This action provides a means to alter `aPortAdminState` and exert a BEGIN on the Auto-Partition state machine (Figure 9–6) upon taking the value “enabled”.





## 20. Layer Management for 10 Mb/s baseband medium attachment units

Clause 20 is deprecated by Clause 30.

### 20.1 Introduction

The MAU Management specification has been developed in accordance with the Open Systems Interconnection (OSI) management architecture as specified in ISO/IEC 7498-4: 1989.

#### 20.1.1 Scope

This clause defines a set of mechanisms that enable management of IEEE 802.3 10 Mb/s integrated Medium Attachment Units (MAUs). In addition, for ports without integral MAUs, attributes are provided for characteristics observable from the AUI of the connected DTE or repeater. Direct management of MAUs that are external to their respective DTEs or repeaters is beyond the scope of this standard. The managed objects within this standard are defined as sets of attributes, actions, notifications, and behaviours in accordance with IEEE Std 802.1-1990 and ISO/IEC International Standards for network management. This clause builds upon the concepts and terminology that are defined more fully in Clause 19.

This standard is defined to be independent of any particular management application or management protocol. The means by which the managed objects defined in this standard are accessed is beyond the scope of this standard.

#### 20.1.2 Management model

See 19.1.5.

## 20.2 Managed objects

### 20.2.1 Text description of managed objects

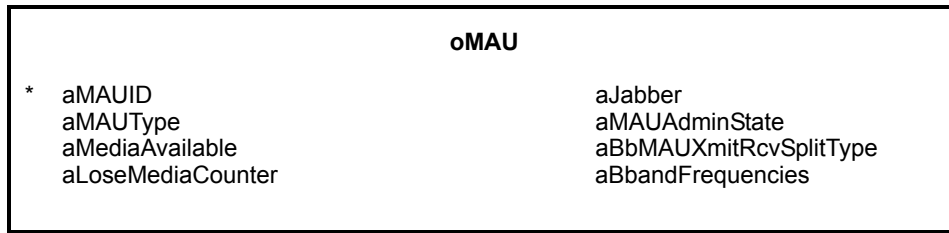
In case of conflict, the formal behaviour definitions in Annex H.3 take precedence over the text descriptions in this clause.

- a) **oRepeaterPort.** The managed object that contains the MAU managed object in a repeater set.
- b) **oDTEPort.** The managed object that contains the MAU managed object in a DTE.
- c) **oMAU.** The managed object of that portion of the containment tree shown in Figure 20–1. The attributes, notifications and actions defined in this clause are contained within the MAU managed object.

Neither counter values nor the value of aMAUadminState is required to be preserved across events involving the loss of power.

#### 20.2.1.1 Naming

The name of an individual managed object is hierarchically defined within a managed system. In the case of MAU management, this will present itself in one of the two forms that are appropriate for a MAU's use, that is, as associated with a CSMA/CD interface of a DTE or with a particular port of a managed repeater. For example, a MAU could be identified as "repeater 3, group 01, port 13, mau 1," that is, the MAU associated with port 13 of group 01 of a repeater with repeaterID 3 within the managed system. An example of this is represented in the relationship of the naming attributes in the Entity Relationship Diagram, Figure 19–3.



NOTE—The \* denotes naming attribute.

**Figure 20–1—Entity relationship diagram**

### 20.2.1.2 Containment

A containment relationship is a structuring relationship for managed objects in which the existence of a managed object is dependent on the existence of a containing managed object. The contained managed object is said to be the subordinate managed object, and the containing managed object the superior managed object. MAU management is only valid in a system that provides management at the next higher containment level, that is, either a DTE or Repeater with Layer Management. The containment relationships among object classes are depicted in the Entity Relationship Diagram, Figure 20–1, and specified in the name bindings in Annex H, H.3.1.

### 20.2.1.3 Packages

This standard and ISO/IEC guidelines make provision for grouping attributes, actions, and notifications in implementation groups, or “packages,” within each managed object class. The “Basic Control Package” is mandatory; all other packages are optional. For a managed MAU to be conformant to this standard, it shall fully implement the Basic Control Package. For a MAU to be conformant to an optional package, it shall implement that entire package. While nonconformant (reference aMAUType = “other”) MAUs may utilize some or all of this clause to specify their management, conformance to this clause requires both a conformant MAU and conformant management. MAU Management is optional with respect to all other CSMA/CD Management. The packages are summarized in Table 20–1.

**Table 20–1—Packages**

Broadband DTE MAU Package (Conditional)				
Media Loss Tracking Package (Conditional)				
MAU Control Package (Optional)				
Basic Package (Mandatory)				
MAU managed object class				
aMAUID	ATTRIBUTE	GET	X	
aMAUType	ATTRIBUTE	GET	X	
aMediaAvailable	ATTRIBUTE	GET	X	
aLoseMediaCounter	ATTRIBUTE	GET		X
aJabber	ATTRIBUTE	GET	X	
aMAUAdminState	ATTRIBUTE	GET	X	
aBbMAUXmitRcvSplitType	ATTRIBUTE	GET		X
aBroadbandFrequencies	ATTRIBUTE	GET		X
acResetMAUAction	ACTION			X
acMAUAdminControl	ACTION			X
nJabber	NOTIFICATION		X	

**20.2.2 MAU Managed object class**

This subclause formally defines the behaviours for MAU Management objects, attributes, actions, and notifications.

**20.2.2.1 MAU attributes**

**20.2.2.1.1 aMAUID**

ATTRIBUTE

APPROPRIATE SYNTAX:

INTEGER

BEHAVIOUR DEFINED AS:

The value of aMAUID is assigned so as to uniquely identify a MAU among the subordinate managed objects of the containing object.

**20.2.2.1.2 aMAUType**

ATTRIBUTE

APPROPRIATE SYNTAX:

An INTEGER that meets the requirements of the description below. Additional values are needed for following types:

global            --reserved for future use

other             --see 20.2.1.3

unknown          --initializing, true state or type not yet known

BEHAVIOUR DEFINED AS:

Returns a value that identifies the 10 Mb/s internal MAU type. The enumeration of the type is such that the value matches the clause number of the standard that specifies the particular MAU. If an AUI is to be identified to access an external MAU, then type “AUI” is returned.

### 20.2.2.1.3 aMediaAvailable

ATTRIBUTE

APPROPRIATE SYNTAX:

An ENUMERATED value list that has the following entries:

other	--undefined
unknown	--initializing, true state not yet known
available	--link or light normal, loopback normal
not available	--link loss or low light, no loop back
remote fault	--remote fault, applies only to 10BASE-FB
invalid signal	--invalid signal, applies only to 10BASE-FB

BEHAVIOUR DEFINED AS:

If the MAU is a link or fiber type (FOIRL, 10BASE-T, 10BASE-F), then this is equivalent to the link test fail state/low light function. For an AUI or a coaxial cable (including broadband) MAU, this indicates whether or not loopback is detected on the DI circuit. The value of this attribute persists between packets for MAU types AUI, 10BASE5, 10BASE2, 10BROAD36, and 10BASE-FP.

At power-up or following a reset, the value of this attribute will be “unknown” for AUI, 10BASE5, 10BASE2, 10BROAD36, and 10BASE-FP MAUs. For these MAUs, loopback will be tested on each transmission during which no collision is detected. If DI is receiving *input* when DO returns to IDL after a transmission and there has been no collision during the transmission, then loopback will be detected. The value of this attribute will only change during noncollided transmissions for AUI, coaxial cable, and 10BASE-FP MAUs.

### 20.2.2.1.4 aLoseMediaCounter

ATTRIBUTE

APPROPRIATE SYNTAX:

Generalized nonresetable counter. This counter has a maximum increment rate of 10 counts per second.

BEHAVIOUR DEFINED AS:

Counts the number of times that the MAU leaves MediaAvailState “available.” Mandatory for MAU type “AUI,” optional for all others.

### 20.2.2.1.5 aJabber

ATTRIBUTE

APPROPRIATE SYNTAX:

A SEQUENCE of two indications.

The first, JabberFlag, consists of an ENUMERATED value list that has the following entries:

other	--undefined
unknown	--initializing, true state not yet known
normal	--state is true or normal
fault	--state is false, fault, or abnormal

The second, jabberCounter, is a generalized nonresetable counter. This counter has a maximum increment rate of 40 counts per second.

BEHAVIOUR DEFINED AS:

If the MAU is in the jabber state, the jabberFlag portion of the attribute is set to the “fault” value. The jabberCounter portion of the attribute is incremented each time the flag is set to the “fault” value. This attribute returns the value “other” for type AUI.

**20.2.2.1.6 aMAUAdminState**

ATTRIBUTE

APPROPRIATE SYNTAX:

An ENUMERATED value list that has the following entries:

other	--undefined
unknown	--initializing, true state not yet known
operational	--powered and connected
standby	--inactive but on
shutdown	--similar to power down

BEHAVIOUR DEFINED AS:

A MAU in management state “standby” forces DI and CI to idle and the media transmitter to idle or fault, if supported. The management state “standby” only applies to link type MAUs. The state of MediaAvailable is unaffected. A MAU or AUI in the management state “shutdown” assumes the same condition on DI, CI, and the media transmitter as if it were powered down or not connected. For an AUI, this management state will remove power from the AUI. The MAU may return the value “undefined” for Jabber and MediaAvailable attributes when it is in this management state. A MAU in the management state “operational” is fully functional, and operates and passes signals to its attached DTE or repeater port in accordance to its specification.

**20.2.2.1.7 aBbMAUXmitRcvSplitType**

ATTRIBUTE

APPROPRIATE SYNTAX:

An ENUMERATED value list that has the following entries:

other	--undefined
single	--single-cable system
dual	--dual-cable system, offset normally zero

BEHAVIOUR DEFINED AS:

Returns a value that indicates the type of frequency multiplexing/cabling system used to separate the transmit and receive paths for the 10BROAD36 MAU. All other types return “undefined.”

**20.2.2.1.8 aBroadbandFrequencies**

ATTRIBUTE

APPROPRIATE SYNTAX:

A SEQUENCE of two instances of the type INTEGER.

The first INTEGER represents the Transmitter Carrier Frequency. The value of its integer represents the frequency of the carrier divided by 250 kHz. The second INTEGER represents the Translation Offset Frequency. The value of its integer represents the frequency of the offset divided by 250 kHz.

BEHAVIOUR DEFINED AS:

Returns a value that indicates the transmit carrier frequency and translation offset frequency in MHz/4 for the 10BROAD36 MAU. This allows the frequencies to be defined to a resolution of 250 kHz.

## 20.2.2.2 MAU actions

### 20.2.2.2.1 acResetMAU

ACTION

APPROPRIATE SYNTAX:

None required.

BEHAVIOUR DEFINED AS:

Resets the MAU in the same manner as would a power-off, power-on cycle of at least 0.5 s duration. During the 0.5 s DO, DI, and CI should be idle.

### 20.2.2.2.2 acMAUAdminControl

ACTION

APPROPRIATE SYNTAX:

The same as used for **aMAUAdminState**

BEHAVIOUR DEFINED AS:

Executing an acMAUAdminControl action causes the MAU to assume the aMAUAdminState attribute value of one of the defined valid management states for control input. The valid inputs are “standby,” “operational,” and “shutdown” state (see the behaviour definition bMAUAdminState for the description of each of these states) except that a “standby” action to a mixing type MAU or an AUI will cause the MAU to enter the “shutdown” management state.

## 20.2.2.3 MAU notifications

### 20.2.2.3.1 nJabber

NOTIFICATION

APPROPRIATE SYNTAX:

The same as used for **aJabber**

BEHAVIOUR DEFINED AS:

The notification is sent whenever a managed MAU enters the jabber state.

## Annex A

(informative)

### Bibliography

[B1] AMP, Inc., Departmental Publication 5525, Design Guide to Coaxial Taps. Harrisburg, PA 17105, USA.

[B2] AMP, Inc., Instruction Sheet 6814, Active Tap Installation. Harrisburg, PA 17105, USA.

[B3] ANSI/EIA 364A: 1987, Standard Test Procedures for Low-Frequency (Below 3 MHz) Electrical Connector Test Procedure.

[B4] ANSI/EIA/TIA 455-30B-1991 (FOTP-30), Frequency Domain Measurement of Multimode Optical Fiber Information Transmission Capacity.

[B5] ANSI/EIA 455-34: 1985, Fiber Optics—Interconnection Device Insertion Loss Test.

[B6] ANSI/EIA/TIA 455-51A-1991 (FOTP-51), Pulse Distortion Measurement of Multimode Glass Optical Fiber Information, Transmission Capacity.

[B7] ANSI/EIA/TIA 455-54A-1990 (FOTP-54), Mode Scrambler Requirements for Overfilled Launching Conditions to Multimode Fibers.

[B8] ANSI/EIA/TIA 455-59-1989, Measurement of Fiber Point Defects Using an Optical Time Domain Reflectometer (OTDR).

[B9] ANSI/EIA 455-95-1986, Absolute Optical Power Test for Optical Fibers and Cables.

[B10] ANSI/EIA/TIA 455-127-1991 (FOTP-127), Spectral Characterization of Multimode Lasers.

[B11] ANSI/EIA/TIA 455-180-1990 (FOTP-180), Measurement of the Optical Transfer Coefficients of a Passive Branching Device (Coupler).

[B12] ANSI/EIA/TIA 526-14-1990, Optical Power Loss Measurements of Installed Multimode Fiber Cable Plant.

[B13] ANSI/IEEE Std 770X3.97-1983, IEEE Standard Pascal Computer Programming Language.<sup>40</sup>

[B14] ANSI/NFPA 70-1996, National Electrical Code<sup>®</sup> (NEC<sup>®</sup>).

[B15] ANSI/TIA/EIA 526-4A-1997 (OFSTP-4), Optical Eye Pattern Measurement Procedure.

[B16] ANSI/TIA/EIA 526-14A-1998, Optical Power Loss Measurements of Installed Multimode Fiber Cable Plant.

[B17] ANSI/TIA/EIA 526-7-1998, Measurement of Optical Power Loss of Installed Single-Mode Fiber Cable Plant.

---

<sup>40</sup>ANSI/IEEE Std 770X3.97-1983 has been withdrawn; however, copies can be obtained from Global Engineering, 15 Inverness Way East, Englewood, CO 80112-5704, USA, tel. (303) 792-2181.

- [B18] ANSI/TIA/EIA-568-A-1995, Commercial Building Telecommunications Cabling Standard.
- [B19] ANSI/TIA/EIA-568-B: 2001, Commercial Building Telecommunications Cabling Standard.
- [B20] ANSI/UL 94-1990, Tests for Flammability of Plastic Materials for Parts in Devices and Appliances.
- [B21] ANSI/UL 1950-1994, Safety Standard for Information Technology Equipment Including Electrical Business Equipment.
- [B22] ANSI X3.230-1994 (FC-PH), Information Technology—Fibre Channel—Physical and Signaling Interface.
- [B23] Blahut, Richard E., *Theory and Practice of Error Control Codes*, Addison-Wesley, May 1, 1983.
- [B24] Brinch, Hansen, P. *The Architecture of Concurrent Programs*. Englewood Cliffs, NJ: Prentice Hall, 1977.
- [B25] Digital Equipment Corporation, Intel, Xerox, The Ethernet, Version 2.0, November 1982.
- [B26] ECMA-97 (1985), Local Area Networks Safety Requirements.
- [B27] EIA CB8-1981, Components Bulletin (Cat 4) List of Approved Agencies, U.S. and Other Countries, Impacting Electronic Components and Equipment.
- [B28] ETSI EN 300 019-1-3, Equipment Engineering (EE); Environmental conditions and environmental tests for telecommunications equipment Part 1–3: Classification of environmental conditions Stationary use at weatherprotected locations.
- [B29] ETSI EN 300 019-1-4, Equipment Engineering (EE); Environmental conditions and environmental tests for telecommunications equipment Part 1–3: Classification of environmental conditions Stationary use at non-weatherprotected locations.
- [B30] FCC Docket 20780-1980 (Part 15), Technical Standards for Computing Equipment. Amendment of Part 15 to redefine and clarify the rules governing restricted radiation devices and low-power communication devices. Reconsidered First Report and Order, April 1980.
- [B31] *Fiber Channel Jitter Working Group Technical Report*, Rev. 1.0, Draft E. February 17, 1997.<sup>41</sup>
- [B32] Forney, G., David, “Coset Codes I,” *IEEE Transactions in Information Theory*, Vol. 34, No 5, pp. 1123-1151, Sept. 1988.
- [B33] Gallagher, Robert, G. *Low-Density Parity-Check codes*, The MIT Press, Cambridge, MA, September 15, 1963.
- [B34] GR-468-CORE, Generic Reliability Assurance Requirements for Optoelectronic Devices Used in Telecommunications Equipment.
- [B35] GR-487-CORE, Generic Requirements for Electronic Equipment Cabinets.
- [B36] GR-63-CORE, NEBS Requirements: Physical Protection.

---

<sup>41</sup>This document is available via FTP at [ftp://www.t11.org/t11/pub/fc/jitter\\_meth/98-055v5.pdf](ftp://www.t11.org/t11/pub/fc/jitter_meth/98-055v5.pdf).



- [B37] Hammond, J. L., Brown, J. E., and Liu, S. S. Development of a Transmission Error Model and Error Control Model. Technical Report RADC-TR-75-138. Rome: Air Development Center (1975).
- [B38] IEC 60721-2-1, Classification of environmental conditions—Part 2-1: Environmental conditions appearing in nature—Temperature and humidity, Edition 1.1.
- [B39] IEC 60793-1-4: 1995, Optical fibres—Part 1: Generic specification—Section 4: Measuring methods for transmission and optical characteristics.
- [B40] IEC 61754-4: 1997, Fibre optic connector interfaces—Part 4: Type SC connector family.
- [B41] IEC 62149-1:2004, Fiber optics active components and devices: Performance standards—Part 1: General and guidance.
- [B42] IEC 62255, Multicore and symmetrical pair/quad cables for broadband digital communications (High bit rate Digital access Telecommunication Network).
- [B43] IEEE 100, a glossary of standards terms titled *The Authoritative Dictionary of IEEE Standards Terms*, New York, Institute of Electrical and Electronics Engineers, Inc.
- [B44] IEEE Std 610.7<sup>TM</sup>-1995, IEEE Standard Glossary of Computer Networking Terminology.
- [B45] IEEE Std 802.9a<sup>TM</sup>-1995, IEEE Standards for Local and Metropolitan Area Networks: Integrated Services (IS) LAN: IEEE 802.9 Isochronous Services with Carrier Sense Multiple Access with Collision Detection (CSMA/CD) Media Access Control (MAC) Service.
- [B46] IEEE Std 1394<sup>TM</sup>-1995, IEEE Standard for a High-Performance Serial Bus.
- [B47] ITU-T Y.1730 Recommendation—Requirements for OAM functions in Ethernet based networks, 2004.
- [B48] Lin, Shu and Daniel J. Costello, *Error Control Coding*, Prentice Hall; 2nd edition, April 1, 2004.
- [B49] MIL-C-17F-1983, General Specification for Cables, Radio Frequency, Flexible and Semirigid.
- [B50] MIL-C-24308B-1983, General Specifications for Connector, Electric, Rectangular, Miniature Polarized Shell, Rack and Panel.
- [B51] OIF-SF14-01.0, Proposal for a common electrical interface between SONET framer and serializer/deserializer parts for OC-192 interfaces.<sup>42</sup>
- [B52] Shoch, J. F., Dalal, Y. K., Redell, D. D., and Crane, R. C., “The Evolution of Ethernet,” *Computer Magazine*, August 1982.
- [B53] Swenson, N, et al., “Explanation of IEEE 802.3, Clause 68 TWDP,” 2005.<sup>43</sup>
- [B54] TIA/EIA TSB 67 (1995), Transmission Performance Specifications For Field Testing Of Unshielded Twisted-pair Cabling Systems.
- [B55] UL Subject No 758: UL VW-1, Description of Appliance Wiring Material.

<sup>42</sup>This document is available at the URL <http://www.oiforum.com/public/documents/OIF-SF14-01.0.pdf>.

<sup>43</sup>This document is available at the URL <http://ieee802.org/3/qa/public/tools/TWDP.pdf>.

[B56] Ungerboeck, G., "Channel coding with multilevel/phase signals", IEEE Transactions on Information Theory, vol 28, pp. 55067, Jan. 1982.

## Annex B

(informative)

### System guidelines

#### B.1 Baseband system guidelines and concepts, 10 Mb/s

##### B.1.1 Overall system objectives

The CSMA/CD Access Method, supported by baseband technology, depends on a variety of analog system components at and below the physical level of the OSI Reference Model. These components provide basic interconnection facilities for the CSMA/CD access mechanism itself and are defined throughout Clause 6, Clause 7, and Clause 8.

Overall performance of the analog baseband medium and related Physical Layer capabilities depends on an optimal and known set of analog capabilities within each of these critical system elements: the coaxial trunk cable, MAUs, branch cables, DTEs, and repeater units. These system elements affect the integrity with which the serial data bit stream analog signals are carried between open systems. There are at least three critical parameters of interest: bits lost in the transmission system, signal delays, and phase jitter. It is important that these be apportioned properly among the affected system elements.

The successful interconnection of multivendor system components mandates that the values for bits lost, signal delays, and phase jitter be allocated fairly and realistically among the various system elements. The balance of Annex B identifies the upper limits of values to be placed on the subject parameters. These values are based on the maximal system configuration (for example, four repeater units, 2.5 km trunk coaxial cable medium).

##### B.1.2 Analog system components and parameter values

The values given in the following table are in terms of bits and are stated as maximum values except for values given within ranges.

The initial mnemonic under each component entry refers to the system component as identified in Figure B–1. System parameters are stated in terms of the intralayer or interlayer messages sent within a station. Specific delays are called out as = delay.

The repeater concepts described throughout this annex are considered to be an acceptable set of specifications for a multirepeated system. It is noted that the exact parametric values specified for the repeater environment are subject to minor refinement.

Component and parameter	Start-up delay	Last in to last out delay	Start-up loss
<b>MEDIUM</b> Trunk Coaxial Cable C1 Propagation	0.0	21.65	0.0
<b>POINT-TO-POINT LINK</b> P1 Propagation AUI A1 Propagation	0.0 0.0	25.64 2.57	0.0 0.0
<b>MEDIUM ACCESS UNIT</b> M1 DATA IN ASSERT → INPUT M2 OUTPUT → DATA OUT ASSERT M3 DATA IN COLLISION → SQE ASSERT M4 COLLISION DEASSERT → SQE DEASSERT M5 OUTPUT IDLE → SQE ASSERT M6 SQE TEST ASSERT → SQE DEASSERT	6.0 3.0 17.0 20.0 $6 < x < 16$ $5 \leq x \leq 15$	0.5 0.5 — — — —	5.0 2.0 — — — —
<b>DTE</b> D1 INPUT → INPUT UNIT D2 OUTPUT UNIT → OUTPUT D3 INPUT → CARRIER STATUS = CARRIER ON D4 INPUT IDLE → CARRIER STATUS = OFF D5 SQE ASSERT → CARRIER STATUS = ON D6 SQE DEASSERT → CARRIER STATUS = OFF D7 SQE ASSERT → SIGNAL STATUS = ERROR D8 SQE DEASSERT → SIGNAL STATUS = NO ERROR D9 CARRIER STATUS = OFF → OUTPUT UNIT D10 INPUT → OUTPUT D11 SIGNAL STATUS = ERROR → JAM OUTPUT D12 JAM OUTPUT DURATION	18.0 — 3.0 $3.0 < x \leq 6.0$ 3.0 $3.0 < x \leq 6.0$ 3.0 $3.0 < x \leq 6.0$ $96 \leq x \leq 100$ 8.0 16.0 =32.0	— 3.0 — — — — — — — — — —	18.0 — — — — — — — — — — —
<b>REPEATER UNIT</b> R1 INPUT 1,2 → OUTPUT 2,1 R2 INPUT IDLE 1,2 → OUTPUT IDLE 2,1 R3 INPUT 1,2 → CARRIER STATUS = ON R4 SQE → SOURCED OUTPUT R5 JAM OUTPUT → OUTPUT IDLE	7.5 — 3.0 6.5 =96.0	— 12.5 — — —	$22 < x < 34$ — — — —

Figure B-1 indicates the maximal system configuration and identifies the various system component parameters considered critical in determining analog system performance.

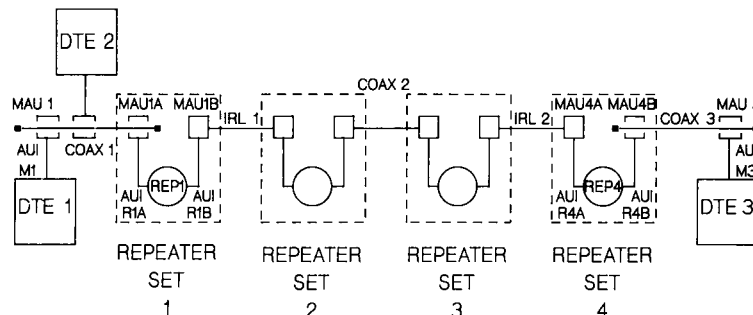


Figure B-1—Maximal system configuration bit budget apportionments

### B.1.3 Minimum frame length determination

The following table indicates the system elements that make up the minimum frame length calculation based on the worst-case numbers as outlined in the bit budget of B.1.2. The compilation in the following table is based on the following scenario:

- a) DTE 1 transmits to an adjacent DTE 2 on coaxial segment 1.
- b) DTE 3 transmission collides with DTE 1 transmission.
- c) DTE 3 is assumed to be the worst-case distance from DTE 1 and its transmission just misses deferring to the DTE 1 message.
- d) The collision fragment travels back down the network to inform DTE 1 that a collision has occurred on its message.

Component and function	Direction	Table entry	Delay	Total delay
<b>DTE 1 STARTS TO PUT OUT FIRST BIT</b>				
DTE 1	FWD	D2	3.0	3.0
AUI M1	FWD	A1	2.57	5.57
MAU1	FWD	M2	3.0	8.6
COAX1	FWD	C1	21.65	30.2
<b>REPEATER SET 1</b>				
MAU 1A	FWD	M1	6.0	36.2
AUI R1A	FWD	A1	2.57	38.8
REP 1	FWD	R1	7.5	46.3
AUI R1B	FWD	A1	2.57	48.9
MAU 1B	FWD	M2	3.0	51.9
<b>REPEATER SET TOTAL</b>			21.64	
IRL 1	FWD	P1	25.64	77.5
REPEATER SET 2	FWD		21.6	99.1
COAX 2	FWD	C1	21.65	120.8
REPEATER SET 3	FWD		21.6	142.4
IRL 2	FWD	P1	25.64	168.1
REPEATER SET 4	FWD		21.6	189.7
COAX 3	FWD	C1	21.65	211.4
MAU 3	FWD	M1	6.0	217.4
AUI 3	FWD	A1	2.57	219.9
DTE 3 PUTS OUT A BIT	REV	D10	8.0	227.9
AUI 3	REV	A1	2.57	230.5
MAU 3	REV	M2	3.0	233.5
COAX 3	REV	C1	21.65	255.1
<b>REPEATER SET 4</b>				
MAU 4B	REV	M3	17.0	272.1
AUI 4B	REV	A1	2.57	274.7
REP 4	REV	R4	6.5	281.2
AI 4A	REV	A1	2.57	283.8
MAU 4A	REV	M2	3.0	286.8
<b>REPEATER SET TOTAL</b>			31.64	
IRL 2	REV	P1	25.64	312.4
REPEATER SET 3	REV		31.64	344.1
COAX 2	REV	C1	21.65	365.7
REPEATER 2	REV		31.64	397.4
IRL 1	REV	P1	25.64	423.0
REPEATER SET 1	REV		31.64	454.6
COAX 1	REV	C1	21.65	476.3
MAU 1	REV	M3	17.0	493.3
AUI M1	REV	A1	2.57	495.9
DTE 1	REV	D7	3.0	498.9

The frame length is constrained by two parameters:

- The message from DTE 1 shall be long enough so that it is still sending when the collision is detected.
- The message from DTE 1 shall be short enough such that DTE 2 can throw out the message on the basis of being too short.

The above table provides the scenario that enables DTE 1 to determine a collision is taking place. DTE 1 shall transmit for at least 499 bit times. To determine how much longer DTE 2 will continue to receive bits, assume that DTE 1 is the last transmitter to provide bits to the DTE 2 MAU. DTE 2 then sees the following:

Component and function	Direction	Table entry	Delay	Total delay
DTE 1	FWD	D11	16.0	514.9
DTE 1	FWD	D12	32.0	547.9
AUI M1	FWD	A1	2.57	549.4

If Repeater Set 1 is the last system component to provide bits to DTE 2, then DTE 2 will see the following:

Component and function	Direction	Table entry	Delay	Total delay
REPEATER SET 1 (1st JAM BIT)				454.6
REP 1	REV	R5	96.0	550.6
COAX 1	REV	C1	21.65	572.3

The Repeater Set is the last transmitter to provide a bit to DTE 2. The DTE 2 MAU starts seeing bits at time 8.6, which means that DTE 2 sees 563.7 bits ( $572.3 - 8.6$ ). DTE 2 sees a minimum of 61 preamble bits and 8 SFD bits. The preamble and SFD bits can be deleted from the 563.7 total because they are not counted in minimum frame length.

The minimum frame length determination from the above scenario is then  $564.7 - 69.0 = 494.7$  bits. The 10 Mb/s system value for minimum frame length has been set at 512 bits.

### B.1.4 System jitter budgets

The typical jitter budget expected for the baseband system is apportioned in the following manner:

Encoder	0.5 ns
AUI Cable	1.0 ns (transmit end)
MAU Transmit	2.0 ns
Trunk Coax	7.0 ns
MAU Receive	-1.0 ns (with compensation)
AUI Cable	1.0 ns (receive end)
SNR on COAX	5.0 ns (SNR = 5:1)
SNR on AUI	0.5 ns (SNR = 5:1, transmit end)
SNR on AUI	0.5 ns (SNR = 5:1, receive end)
	16.5 ns

The 18 ns jitter budget leaves adequate design margin for implementation-dependent considerations.

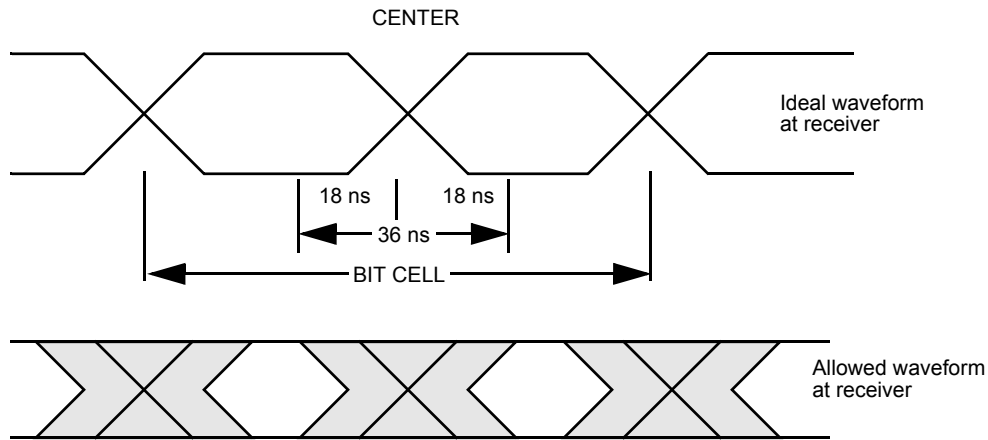
#### B.1.4.1 Nominal jitter values

The jitter budget values given above are not expected to accommodate all step changes in phase jitter due to system parameter variations within one or a few bit times.

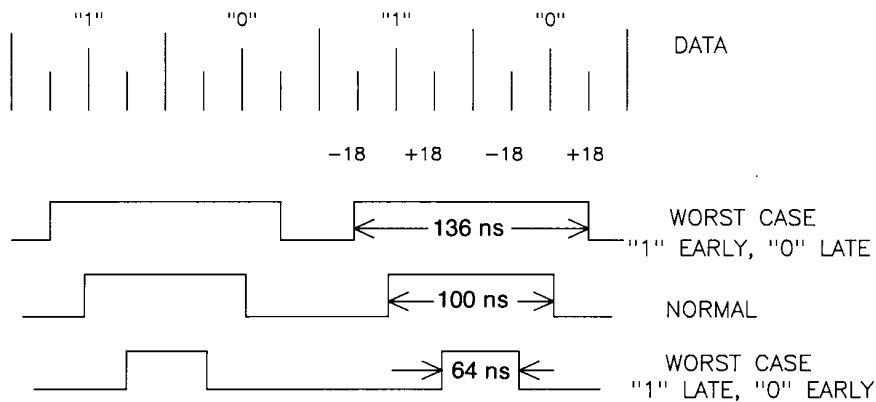
**B.1.4.2 Decoder evaluation**

The phase decoder in the PLS sublayer should correctly decode a Manchester-encoded signal whose data transition point (center of a bit cell) has a peak-to-peak jitter of no more than 36 ns ( $\pm 18$  ns deviation from the bit cell center). Figure B-2 and Figure B-3 show the test method.

Evaluation of decoder performance may be simulated and tested by application of three distinct waveforms representing worst-case and normal conditions. The waveforms contain Manchester-encoded bits whose center transitions represent the extremes of maximum skew. A 5 MHz (repetition rate) pulse train whose pulse width is either 64 ns or 136 ns simulates the two worst-case jitter conditions. The data output from the decoder should remain stable for each of the three test patterns and shifts between these extremes where there is a low rate of change in center transition skew. Note that the actual transmission system is not expected to permit sudden drastic changes in the steady-state edge deviation during the reception of any given frame. The above evaluation process is not intended to guarantee proper decoder performance under all operating conditions.



**Figure B-2—Typical signal waveforms**



**Figure B-3—Worst-case signal waveform variations**

## B.1.5 Systems consideration calculations

### B.1.5.1 Overview

Subclause B.1.3 contains a calculation of maximum fragment size for a network of 10BASE5 and IRL segments. That calculation was based on the maximum delay for a transmission to reach the far end of the network and for a collision to propagate back. Since that calculation was written, many new media and MAU types have been added to this standard. Also, the calculation of B.1.3 did not address the interpacket gap shrinkage, which can limit the network size. It is not practical to perform a separate calculation for each possible combination of segment types.

Some new segment types also support much longer media (up to 2 km). Introduction of longer media also required a more flexible calculation method that allowed trading segment length for repeaters. The method in this section was developed to meet these needs.

Actual numbers used to calculate delay and variability are tabulated (Table B-1) at the end of this subclause.

### B.1.5.2 Maximum collision fragment size

The round-trip delay must be calculated to determine that collision will be received within the collision window of transmitting DTEs and that collision fragments will be less than the minimum frame size. The following scenario is used for the calculations (see Figure B-4):

- a) DTE1 transmits.
- b) DTE1's transmission propagates to DTE2.
- c) DTE2 begins transmitting at the last possible time, colliding and transmitting 96 bits.
- d) DTE2's transmission propagates to DTE1.
- e) DTE1 detects collision, jams, and stops transmitting.

The following conditions must be met for proper network operation:

- DTE1 must detect collision before having transmitted the 512th bit (including preamble and SFD bits).
- DTE1 must stop transmitting before having transmitted a minimum length frame, 576 bits (512 bits after SFD).
- The overlap between DTE1's transmission and DTE2's transmission must be less than 575 bits (511 bits after the SFD transmitted by DTE1).

For all existing segment types, the last condition is the limiting factor; if it is met then the other two conditions are also met.

The maximum time between the first bit and the last bit of the overlapping transmissions of the two DTEs colliding across a path will be called the Path Delay Value (PDV). Many factors contribute to this delay. Simplification of the delay calculation, as compared to the method used in B.1.3, can be achieved by using a set of base numbers, Segment Delay Values (SDV), for each segment type that combines the factors that contribute to the round-trip delay associated with that segment. The PDV is the sum of SDVs of the segments that comprise the path.

For each segment type, one of three base SDVs is used depending on the position of the segment: left-end, mid-, or right-end. The left-end segment is connected to the DTE that transmits first (DTE1). The right-end segment is connected to the colliding DTE (DTE2). All segments between these are mid-segments.

For this calculation, the left-end base SDV contains all delays from DTE1 through the MAU and its AUI connected to the repeater unit. Each mid-base SDV includes the delays from the repeater unit on the left



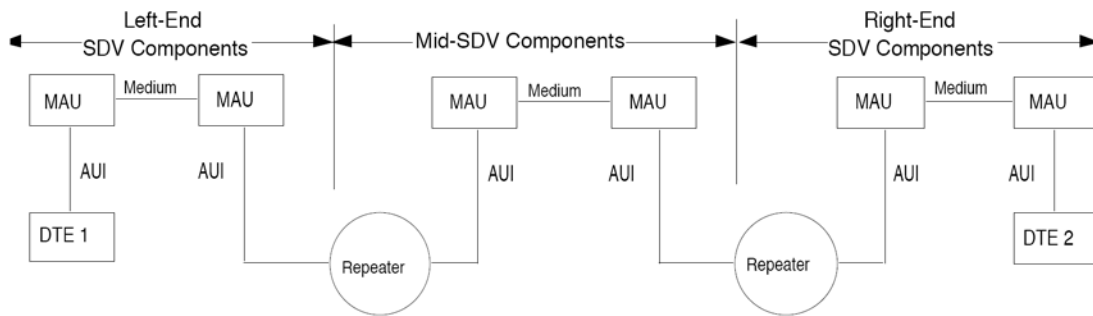
through the MAU and its AUI connected to the right repeater unit. The right-end base SDV includes the delays from the repeater unit immediately to its left through DTE2. (See Figure B–4.)

Only the bit loss of DTE1's MAU on the left-end segment contributes to fragment size. The steady-state delay of that MAU and the AUI cable delay do not contribute. For the remainder of the network, start-up delay (the sum of steady-state delay and bit loss) contribute. Therefore, the left-end base SDV uses MAU transmit bit loss and 1 AUI delay. In all other cases, start-up delay and 2 AUI delays are used.

Propagation delays for media are not included in the base SDVs. These are added in separately to allow for various segment lengths (see 13.4.1). The base SDVs for the mid- and right-end segments (except 10BASE-FB) include two 2 m AUI cables and the delay of each one is experienced twice, once in the forward path and once in the reverse path. Therefore, a delay of 0.5 BT per segment is added and corresponds to the round-trip delay through two 2 m AUI cables. The base numbers for the left segment include one 2 m AUI cable, 0.25 BT.

For each segment type, both the delay to transmission of the 96th bit after collision rise and delay to transmission of the last bit due to collision fall are calculated. The base SDV is the larger of these two.

The maximum allowed sum of SDVs plus media propagation delays is 575 BT.



**Figure B–4—Round-trip delay calculation model**

#### B.1.5.2.1 Left-end base SDV

The Left-End Segment collision delay is the sum of the following:

Forward delay:

- AUI
- MAU transmit bit-loss delay
- Media rise time
- MAU receive start-up delay

Reverse delay:

- MAU transmit fall delay after collision
- MAU receive fall delay after collision

### **B.1.5.2.2 Mid-base SDV**

The Mid-Segment collision rise delay is the sum of the following:

Forward delay:

- AUI  $\times$  2
- Repeater start-of-packet propagation delay
- MAU transmit start-up delay
- Media rise time
- MAU receive start-up delay

Reverse delay:

- MAU transmit start-up delay
- MAU collision detect delay
- Repeater start-of-collision propagation delay

The Mid-Segment collision fall delay is the sum of the following:

Forward delay:

- AUI  $\times$  2
- Repeater start-of-packet propagation delay
- MAU transmit start-up delay
- Media rise time
- MAU receive start-up delay

Reverse delay:

- MAU transmit fall delay
- MAU collision fall delay
- Repeater cessation-of-jam propagation delay

### **B.1.5.2.3 Right-end base SDV**

The Right-End Segment collision rise delay is the sum of the following:

Forward delay:

- AUI  $\times$  2
- Repeater start-of-packet propagation delay
- MAU transmit start-up delay
- Media rise time
- MAU receive start-up delay
- DTE receive-to-transmit-not-deferred delay

Reverse delay:

- MAU transmit start-up delay
- MAU collision detect delay
- Repeater start-of-collision propagation delay
- Repeater minimum transmit length

The Right-End Segment collision fall delay is the sum of the following:

Forward delay:

- AUI  $\times$  2
- Repeater start-of-packet propagation delay
- MAU transmit start-up delay

Media rise time  
 MAU receive start-up delay  
 DTE receive-to-transmit-not-deferred delay  
 DTE minimum transmit length

Reverse delay:

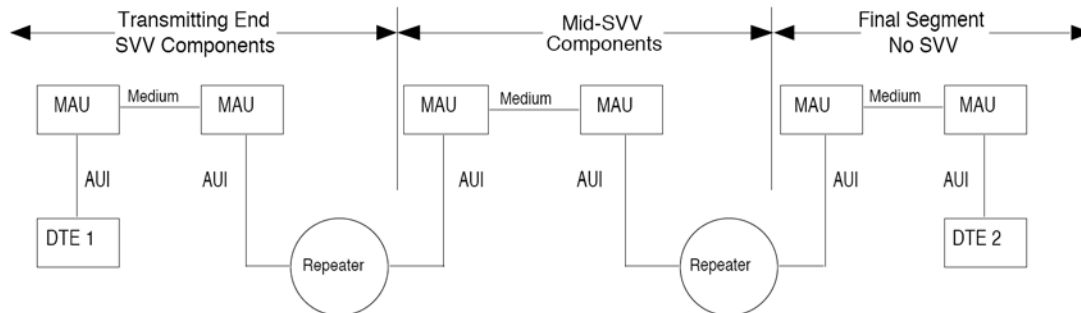
MAU transmit fall delay  
 MAU collision fall delay  
 Repeater cessation-of-jam propagation delay

### B.1.5.3 Interpacket Gap (IPG) shrinkage

IPG shrinkage occurs because two successive packets may experience differing bit loss on the same path. When the packet passes through a repeater, the lost preamble bits are regenerated. If the first packet experiences greater bit loss than the second, the IPG between them will shrink.

IPG shrinkage is also calculated using a lumped number for each segment, the Segment Variability Value (SVV). For each segment type, one of two SVVs is used depending on the position of the segment: transmitting end or mid. The transmitting end segment is connected to the transmitting DTE or DTEs. The mid-segments are all the remaining segments except the one connected to the receiving DTE.

The transmitting end segment and the mid-segment SVVs each include the variability from the transmitting MAU through the repeater unit. Since, IPG shrinkage only occurs when a repeater restores the lost bits, the final segment does not contribute any variability (see Figure B-5).



**Figure B-5—Variability calculation model**

#### B.1.5.3.1 Transmitting end segment variability value

The transmitting end segment variability value is the sum of the following:

- MAU transmit start-up-delay variability
- MAU transmit start-up-delay variability correction
- MAU receive start-up-delay variability
- MAU receive start-up-delay variability correction
- Repeater start-of-packet propagation delay variability
- Clock skew (2.5 BT)

NOTE—The variability correction values account for the possibility that on mixing segments the two successive packets can be originated by two different MAUs.

### **B.1.5.3.2 Mid-segment variability value**

The mid-segment variability value is the sum of the following:

- MAU transmit start-up-delay variability
- MAU receive start-up-delay variability
- Repeater start-of-packet propagation delay variability

### **B.1.5.4 Timing parameters for round-trip delay and variability calculations**

Table B–1 contains the timing parameters used in the calculation of SDVs and SVVs. The values in the table for MAU Collision Rise and MAU Collision Fall are those specific to the worst-case scenario. The parameters are defined in the following subclauses.

#### **B.1.5.4.1 MAU parameters**

**Transmit Bit Loss:** Number of bits received on the DO circuit and not transmitted to the MDI.

**Transmit Start-up Delay:** Delay from the first bit received on the DO circuit to the first bit transmitted to the MDI. This is the sum of transmit bit loss and steady-state delay.

**Receive Start-up Delay:** Delay from the first bit received on the MDI to the first bit transmitted to the DI circuit. This is the sum of receive bit loss and steady-state delay.

**Collision Detect Delay:** Delay from the arrival of collision at the MDI to transmission of signal\_quality\_error to the CI circuit. For 10BASE2 and 10BASE5, this includes the DC rise time on the media, given that the MAU has been transmitting for at least 20 BT when the collision arrives. For 10BASE-FP, this includes the delay until the second CRV occurs on the media (16.3.4.3).

**Transmit Fall Delay:** Delay from the last bit received on the DO circuit to the last bit transmitted to the MDI. This is the same as the steady-state delay.

**Collision Fall Delay:** Delay from arrival of end of collision at the MDI to end of transmission of signal\_quality\_error to the CI circuit. For 10BASE2 and 10BASE5, it includes the DC fall time of the media. For 10BASE-FP it includes the delay of 33 BT to pass with no more than one ORD\_crv.

**Transmit Start-up Delay Variability:** Packet-to-packet variations in transmit start-up delay.

**Transmit Start-up Delay Variability Correction:** Additional variability, when the transmitting end segment is a mixing segment, due to two MAUs transmitting with different start-up delays. For 10BASE5 and 10BASE2, start-up delay variability plus transmit start-up delay variability correction equal transmit start-up delay since these MAUs may transmit with as little as 0 BT delay. For 10BASE-FP MAUs, implementation considerations imposed by the requirements of 16.3.1.1 require the MAU to have at least 2 BT start-up delay. Therefore, the transmit start-up delay variability correction equals the transmit start-up delay minus 2 BT.

**Receive Start-up Delay Variability:** Packet-to-packet variability in receive start-up delay.

**Transmit Fall Delay After Collision:** Delay from the last bit received on the DO circuit to the last bit transmitted to the MDI after the MAU has detected a collision. For all MAUs except 10BASE-FB, this is the same as transmit fall delay.

**Receive Fall Delay After Collision:** Delay from the last bit received on the MDI to the last bit transmitted to DI. For all MAUs except 10BASE-FB and 10BASE-FP, this is the same as receive steady-state delay.

#### **B.1.5.4.2 Repeater parameters**

**Start-of-Packet Propagation Delay:** Delay from first bit received on DI to first bit transmitted on DO.

**Start-of-Collision Propagation Delay:** Delay from start of signal\_quality\_error on CI to first bit transmitted on DO.

**Cessation-of-Jam Propagation Delay:** Delay from end of signal\_quality\_error on CI to last bit transmitted on DO.

**Minimum Transmit Length:** Minimum delay from first bit transmitted on DO to last bit transmitted on DO.

**Start-of-Packet Propagation Delay Variability:** Packet-to-packet variation in start-of-packet propagation delay.

#### **B.1.5.4.3 Media parameters**

**Media Rise Time:** Start-of-packet DC rise time on 10BASE2 and 10BASE5 segments.

#### **B.1.5.4.4 DTE parameters**

**Receive-to-Transmit-Not-Deferred Delay:** Delay from first bit on DI to first bit on DO when the DTE does not detect carrier in time to defer.

**Minimum Transmit Length:** Minimum delay from first bit transmitted on DO to last bit transmitted on DO.

**Table B-1—Timing parameters for round-trip delay and variability calculations in bit times (BT)**

Parameter	10BASE 5	10BASE 2	FOIRL	10BASE -T	10BASE-FP	10BASE-FB	10BASE-FL
AUI (2 m)	0.25	0.25	0.25	0.25	0.25	0.00	0.25
MAU							
Transmit bit loss	3.00	3.00	3.00	3.00	2.00	0.00	3.00
Transmit start-up delay	3.50	3.50	3.50	5.00	5.50	2.00	5.00
Receive start-up delay	6.50	6.50	3.50	8.00	2.50	2.00	5.00
Collision detect delay	17.00	17.00	3.50	9.00	9.50	3.50	3.50
Transmit fall delay	0.50	0.50	0.50	2.00	3.50	2.00	2.00
Collision fall delay	20.00	20.00	7.00	9.00	36.00	5.00	7.00
Transmit start-up delay variability	2.00	2.00	2.00	2.00	3.00	0.00	2.00
Transmit start-up delay variability correction	1.50	1.50	0.00	0.00	0.50	0.00	0.00
Receive start-up delay variability	5.00	5.00	2.00	2.00	1.00	0.00	2.00
Receive start-up delay variability correction	1.00	1.00	0.00	0.00	0.00	0.00	0.00
Transmit fall delay after collision	0.50	0.50	0.50	2.00	3.50	5.00	2.00
Receive fall delay after collision	0.50	0.50	0.50	2.00	3.00	5.00	2.00
REPEATER							
Start-of-packet propagation delay	8.00	8.00	8.00	8.00	8.00	8.00	8.00
Start-of-collision propagation delay	6.50	6.50	6.50	6.50	6.50	6.50	6.50
Cessation-of-jam propagation delay	5.00	5.00	5.00	5.00	5.00	5.00	5.00
Minimum transmit length	96.00	96.00	96.00	96.00	96.00	96.00	96.00
Start-of-packet propagation delay variability	4.00	4.00	4.00	4.00	4.00	2.00	4.00
MEDIA RISE TIME	1.00	1.00	0.00	0.00	0.00	0.00	0.00
DTE							
Receive-to-transmit-not-deferred delay	27.00	27.00	27.00	27.00	27.00	N/A <sup>a</sup>	27.00
Minimum transmit length	96.00	96.00	96.00	96.00	96.00	N/A <sup>a</sup>	96.00

<sup>a</sup>Not applicable; 10 BASE-FB does not support end (DTE) connections.

## B.2 System parameters and budgets for 1BASE5

### B.2.1 Delay budget

The successful interconnection of multivendor system components mandates that the values for bits lost and signal delays be allocated fairly and realistically among the various system elements. The following table summarizes and indicates the derivation of some of the delays specified in 12.9. The breakdowns shown for the parameters are illustrative only; implementors are free to make other allocations of delay *within* a device so long as the specifications of 12.9 are not violated.

Component	Delay (BT)
DTE Initial Transmit Delay (see 12.9.2)	<b>3</b>
DTE Deference Delay (see 12.9.2)	<b>21</b>
unsquelch	3
Carrier detect	5
MAC detects carrier and defers	10
DTE Initial Transmit Delay	3
DTE Collision Shutdown Delay (see 12.9.2)	<b>58</b>
detect CP and report SIGNAL_ERROR	10
detect SIGNAL_ERROR and start jamming	16
jamSize	32
Medium Transit Delay (see 12.9.3)	<b>4</b>
Special Link Transit Delay (see 12.9.4)	<b>15</b>
Hub Startup Delay (see 12.9.5)	<b>12</b>
unsquelch	4
half fill FIFO	6
analogue of DTE Initial Transmit Delay	3
Hub Idle Collision Startup Delay (see 12.9.5) (same as Hub Startup Delay)	<b>12</b>
Hub Transit Delay (see 12.9.5)	<b>9</b>
half fill FIFO	6
analogue of DTE Initial Transmit Delay	3
Hub Delay Stretch/Shrink (see 12.9.5) ( $(\text{preamble} + \text{sfd} + \text{maxFrameSize}) \cdot 0.01\% \cdot 2$ )	<b>3</b>
Hub Collision Detect Delay (see 12.9.5)	<b>21</b>
unsquelch	3
detect collision	6
Hub Transit Delay	9
First CVL or CVH may be preceded by CD0s and CD1s	3
Hub Active Collision Startup Delay (see 12.9.5)	<b>12</b>
Hub Transit Delay	9
First CVL or CVH may be preceded by CD0s and CD1s	3
Hub Collision Shutdown Delay (downward) (see 12.9.5) (same as Hub Transit Delay)	<b>9</b>
Hub Collision Shutdown Delay (upward) (see 12.9.5)	<b>25</b>
detect loss of carrier	20
clear FIFO, if necessary	2
analogue of DTE Initial Transmit Delay	3

## B.2.2 Minimum frame length determination

The minimum frame length for 1BASE5 is determined using the values specified in 4.4.2 and 12.9, applied to the following (worst) case:

- a) DTE 1, connected to Hub 1 at a network extremity, transmits a message upward toward Hub 5.
- b) There is a special link in the path between Hub 1 and Hub 5.
- c) DTE 2, also connected to Hub 1, transmits, just missing deferring to the downward signal from DTE 1 that was wrapped around at Hub 5.
- d) DTE 3, also connected to Hub 1, receives the transmission from DTE 1.
- e) Hub 1 generates CP, which travels up and then back down the network to inform DTE 1 and DTE 2 that a collision has occurred on their messages.
- f) DTE 1 and DTE 2 continue to transmit until they have received CP, reacted to it, and completed their jams.
- g) DTE 3 continues to receive until the end of CP.

The minimum frame length must allow both of the following conditions to be met:

- DTE 1 is still sending when CP is received and recognized.
- DTE 3 can discard the message fragment it receives because it is too short.

Event	Bits	Total
DTE 1 → DTE 2		
DTE Initial Transmit Delay	3	3
8 · Medium Transit Delay	32	35
2 · Special Link Transit Delay	30	65
10 · Hub Startup Delay	120	185
DTE Deference Delay	21	206
DTE 2 → HUB 1 CP		
Medium Transit Delay	4	210
Hub Collision Detect Delay	21	231
HUB 1 CP → HUB 5 CP		
3 · Medium Transit Delay	12	243
Special Link Transit Delay	15	358
4 · max(Hub Startup Delay, Hub Active Collision Startup Delay, Hub Idle Collision Startup Delay)	48	306
HUB 5 CP → DTE 1 receives CP		
5 · Hub Active Collision Startup Delay	60	366
4 · Medium Transit Delay	16	382
Special Link Transit Delay	15	397
DTE 1 receives CP → DTE 1 stops transmitting DTE Collision Shutdown Delay	58	455
COMPUTATION OF MINIMUM FRAME SIZE		
original preamble + <sfd>	-64	391 = data bits transmitted
5 · (Hub Collision Shutdown Delay (upward) – Hub Transit Delay)	80	471
5 · (Hub Collision Shutdown Delay (downward) – Hub Transit Delay)	0	471
Tiny fraction of Hub Delay Stretch/Shrink	0	471 = data bits received

The minimum frame length must exceed both the maximum number of bits sent before recognizing CP (391 – jamsizel = 359) and the maximum collision fragment size (471), as computed above. The 1BASE5 system



value for minimum frame length has been set at 512 bits, which exceeds both of these values with a margin for error.

### B.2.3 Jitter budget

The total edge jitter of the signals on each link must be limited to allow proper decoding at the receiver. The following budget has been used to allocate jitter to the indicated components that contribute to the total jitter on each link:

Component	Jitter (ns)
Transmitter skew	±10
Cable intersymbol interference	9
Cable reflections	8
Reflections due to receiver termination mismatch	5
Total	±32

The cable intersymbol interference and reflection allowances form the basis for the limit specified in 12.7.2.3; the reflection component is sufficient to allow a single 20  $\Omega$  impedance mismatch anywhere along a cable segment. The receiver-mismatch allowance is derived from the reflection attenuation specified in 12.5.3.2.4. The total forms the basis for the specification in 12.5.3.2.2.

The remainder of the jitter that can be tolerated by the Manchester decoder in a receiver is reserved to allow for distortion of the signal due to noise, receiver threshold offset, receiver skew, and receiver sampling timing error.

A simple clocked receiver/decoder with an 8 MHz sampling rate (the worst case allowed for in the design of this standard), can achieve proper decoding with up to  $\pm 125$  ns of jitter between two edges, which is equivalent to  $\pm 62.5$  ns on each edge. Other receiver designs may tolerate more edge jitter. For example, a 6 MHz sampling rate would allow up to  $\pm 83.33$  ns of jitter on each edge and a 16 MHz sampling rate allows up to  $\pm 93.75$  ns of jitter.

It may be necessary to use a low-pass filter as part of the receiver to reduce the noise level seen by that receiver (see 12.7.4 for a description of the noise environment). A filter that reduces the noise may also have an effect on the amplitude and edge rate of the received signal. The filtered signal's edge rate near the zero-crossing is used in the critical translation from mV of noise and receiver offset into ns of jitter.

An example receiver design using an 8 MHz sampling rate and a 2 MHz Butterworth input filter might be based on the following jitter budget:

Component	Jitter (ns)
Input jitter (from above)	±32
Noise and receiver threshold offset	19.5
Receiver skew (analog)	4
Receiver skew (digital)	7
Total	±62.5

The two primary contributors to noise in a 1BASE5 cable are self-crosstalk and impulse noise (see 12.7.4). Because it is unlikely that both will be present at their 1% worst-case levels on any particular cable, the required bit error ratio attributable to each source can be set at half of the one in  $10^8$  error ratio required by 12.5.3.2.6.

Crosstalk noise is specified to be no more than 105 mV (peak) through a 2 MHz filter (see 12.7.4.2). Because crosstalk is present for the entire transmission of a packet, some crosstalk will coincide with the most sensitive part of the received signal. Therefore, the receiver must operate without error in the presence of this 105 mV of noise.

Impulse noise has a peak amplitude of 170 mV for  $\leq 0.005$  counts/s through the 2 MHz filter (see 12.7.4.1). This threshold does not directly correlate to jitter, however, because the derivation of the 62.5 ns jitter tolerance for an 8 MHz clock assumed worst-case sampling error. Assuming a random phasing of the sampling clock to the received signals, it can be shown that the 170 mV of noise is equivalent to a level of 85 mV with a worst-phase clock.

Jitter due to noise should be computed using the larger of the above two levels. The 105 mV for crosstalk noise, therefore, should be added to 50 mV for receiver threshold offset and the result should be divided by the edge rate of the filtered signal near the zero-crossing (7.9 mV/ns for the 2 MHz filter), yielding the 19.5 ns indicated above.

### B.3 Example crosstalk computation for multiple disturbers, balanced-pair cable

A method for computing multiple-disturber, near end, crosstalk attenuation (MDNEXT) into each 1BASE5 pair is specified in 12.7.3.2. This annex provides example computations of MDNEXT using that method when only the distribution of  $X_{ij}$  is known.

The single-disturber probability distribution curve (labelled “1”) shown in Figure B–6 is based on actual measurement of 25-pair, 24-gauge, unshielded, twisted pair cable. The remaining probability distribution curves (labelled with the number of disturbing pairs) were computed using Monte Carlo simulation. To compute each sample  $MDNEXT_j$  for  $N$  disturbers,  $N$  values of crosstalk attenuation ( $X_i$ ) were chosen from the single-disturber distribution and  $N$  values of crosstalk phase ( $\theta_i$ ) were chosen from a uniform distribution between 0 and  $2\pi$  rad. These values were then used with the following equations to compute  $MDNEXT_j$ :

$$H_j = \sum_{1 \leq i \leq N} 10^{(-X_i/20)} \cos \theta_i$$

$$V_j = \sum_{1 \leq i \leq N} 10^{(-X_i/20)} \sin \theta_i$$

$$MDNEXT_j = 10 \log_{10}(H_j^2 + V_j^2)$$

Iterating this process several hundred times, each time producing a single *MDNEXT<sub>j</sub>* sample, resulted in distributions for MDNEXT that are summarized in the following table and Figure B-6:

Disturbers	Iterations	MDNEXT: Mean (dB)	Std. Dev. (dB)	99% (dB)
1		61.2	7.0	48.6
2	500	57.2	6.2	46.4
3	500	55.1	5.8	45.2
6	500	52.0	5.7	42.5
13	1000	48.5	5.4	39.1
18	500	47.1	5.3	37.8
24	500	45.9	5.9	36.2

Because two pairs are used for each 1BASE5 connection, the entries in this table for 18 and 24 disturbers are not applicable for normal installation of 25-pair cables. Furthermore, telephone cables with larger numbers of pairs are often constructed using sub-bundles of 25 pairs each and so might yield similar results (for example, the curves for 13 or fewer disturbers would be the most applicable ones).

The calculation method of this annex, though not the numeric values, applies to 10BASE-T.

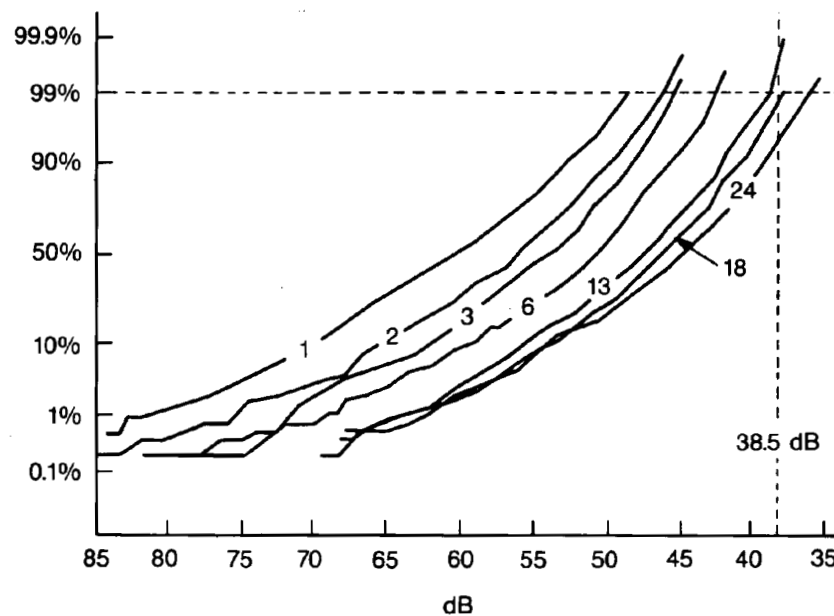


Figure B-6—MDNEXT cumulative probability distribution

## B.4 10BASE-T guidelines

### B.4.1 System jitter budget

The jitter budget for 10BASE-T is apportioned as follows:

Jitter budget	Maximum-length twisted-pair link	Short-length twisted-pair link
	(jitter expressed in $\pm$ ns)	
Encoder	0.5	0.5
AUI cable including SNR (DO pair)	1.5	1.5
MAU transmitter	2.0	2.0
Twisted-pair medium with equalization	1.5	6.0
Noise jitter on twisted-pair medium	8.0	2.5
MAU receiver	1.5	1.5
AUI cable including SNR (DI pair)	1.5	1.5
Total	16.5	15.5

NOTE—Total transmit jitter for the combination of the MAU transmitter and link segment (14.3.1.2.3) is  $\pm 3.5$  ns and  $\pm 8.0$  ns for maximum- and short-length twisted-pair link segments, respectively. It is the sum of the entries for MAU transmitter and twisted-pair medium with equalization. The individual components cannot be easily observed on MAUs. Short-length segment is defined as a short, non-zero-length twisted-pair link. A short- rather than a zero-length segment is used in the calculation since a zero-length segment will have no significant noise and is a less severe case.

### B.4.2 Filter characteristics

The implementation of the 3-pole, low-pass Butterworth filter should have the following characteristics:

3 dB cutoff frequency	15 MHz
Insertion loss (5 MHz to 10 MHz)	$\leq 1.0$ dB
30 MHz attenuation	$\geq 17.5$ dB
Input impedance (5 MHz to 10 MHz)	100 $\Omega$
Return loss with 100 $\Omega$ load (5 MHz to 10 MHz)	$\geq 20$ dB

This filter is only used for the tests described in 14.3.1.3.2, 14.4.4.1, and 14.4.4.2. A buffer may be needed to achieve the above return loss when using an LC implementation of this filter.

### B.4.3 Notes for conformance testing

The following notes are provided to assist in developing the conformance test.

#### B.4.3.1 Notes for 14.3.1.2.1 on differential output voltage

For testing harmonics measured on the TD circuit when the DO circuit is driven by an all-ones Manchester-encoded signal, it is acceptable to use a pattern of maximum length packets whose data field is all ones.

For testing of the maximum and minimum output signal to the template in Figure 14–9, the recommended measurement procedure is described as follows. An oscilloscope set for a zero voltage trigger with a positive slope is allowed to accumulate an eye pattern that must be within the template. Acquisition must be long

enough to ensure that all data variations have been observed. When using packetized data, the TP\_IDLE and the first transmitted bit should be excluded from this measurement. Also, the interpacket interval may be adjusted so that transition-to-idle transient effects are excluded. When testing with the inverted template, the slope of the scope trigger should be negative.

#### B.4.3.2 Note for 14.3.1.2.2 on transmitter differential output impedance

The return loss ( $RL$ ) is defined as follows:

$$RL = 20 \log_{10} \left| \frac{Z_{\text{transmitter}} + Z_{\text{cable}}}{Z_{\text{transmitter}} - Z_{\text{cable}}} \right|$$

and also

$$RL = 20 \log_{10} \left| \frac{V_i}{V_r} \right|$$

where

$Z_{\text{transmitter}}$	is the impedance of the transmitter
$Z_{\text{cable}}$	is the impedance of the cable
$V_i$	is the differential voltage incident upon the transmitter
$V_r$	is the differential voltage reflected from the transmitter

- a) A transmitter with a purely resistive source impedance of  $96 \Omega \pm 20\%$  will satisfy this requirement.
- b) The requirement of 14.3.1.2.2 is equivalent to the following two constraints:
  - 1) The return loss when measured with an  $85 \Omega$  resistive source is at least 15 dB in the frequency range of 5 MHz to 10 MHz.
  - 2) The return loss when measured with a  $111 \Omega$  resistive source is at least 15 dB in the frequency range of 5 MHz to 10 MHz.

#### B.4.3.3 Note for 14.3.1.2.3 on output timing jitter

Adherence to the template of 14.3.1.2.1 with a jitterless source driving DO and the zero crossings constrained to 46.5 ns to 53.5 ns and 96.5 ns to 103.5 ns is sufficient to demonstrate compliance with the 3.5 ns jitter requirement. When measuring an integrated MAU, the zero crossing time interval should be constrained to 44.5 ns to 55.5 ns and 94.5 ns to 105.5 ns due to the additional allocation for encoder and AUI jitter. This test is simpler to perform than the test which follows, but failure of this test does not demonstrate noncompliance.

When triggering on one edge of the transmitted signal and observing another edge, the observed jitter measures the difference between the jitter of the triggering edge and the observed edge. When the two edges are separated such that the jitter of the edges is independent and clock drift is insignificant, the observed jitter is twice that of a single edge.

Therefore, a test that demonstrates compliance or noncompliance is as follows: Observe the zero crossings 8 BT and 8.5 BT from the triggering zero crossing while transmitting a pseudo-random data sequence of at least 511 bits. An external MAU with a jitterless source driving DO is compliant when all zero crossings fall within the time intervals  $8.0 \text{ BT} \pm 7 \text{ ns}$  and  $8.5 \text{ BT} \pm 7 \text{ ns}$ . An integrated MAU is compliant when all zero crossings fall within the time intervals  $8.0 \text{ BT} \pm 11 \text{ ns}$  and  $8.5 \text{ BT} \pm 11 \text{ ns}$ .

When using packetized data, the TP\_IDL and the first transmitted bit should be excluded from these measurements.

#### B.4.3.4 General note on common-mode tests

When performing tests specified as balanced or common-mode, the balance of the test equipment (such as matching resistors) must exceed that required by the test.

#### B.4.3.5 Note for 14.3.1.3.4 on receiver differential input impedance

The return loss ( $RL$ ) is defined as follows:

$$RL = 20 \log_{10} \left| \frac{Z_{\text{receiver}} + Z_{\text{cable}}}{Z_{\text{receiver}} - Z_{\text{cable}}} \right|$$

and also

$$RL = 20 \log_{10} \left| \frac{V_i}{V_r} \right|$$

where

- $Z_{\text{receiver}}$  is the impedance of the receiver
- $Z_{\text{cable}}$  is the impedance of the cable
- $V_i$  is the differential voltage incident upon the receiver
- $V_r$  is the differential voltage reflected from the receiver

- a) A receiver with a resistive input impedance of  $96 \Omega \pm 20\%$  will satisfy this requirement.
- b) The requirement of 14.3.1.3.4 is equivalent to the following two constraints:
  - 1) The return loss when measured with an  $85 \Omega$  resistive source is at least 15 dB in the frequency range of 5 MHz to 10 MHz.
  - 2) The return loss when measured with a  $111 \Omega$  resistive source is at least 15 dB in the frequency range of 5 MHz to 10 MHz.

#### B.4.3.6 Note for 14.3.1.3.3 on receiver idle input behavior

For conformance testing of receivers, the start of idle shall conform to the template shown in Figure 14–10. Additionally, the magnitude of the voltage-time integral of the undershoot (measured from the negative zero crossing that ends the positive idle pulse to the time when the differential signal settles to  $0.0 \text{ mV} \pm 50 \text{ mV}$ ) shall be no greater than 1.2 times the voltage-time integral of the positive idle pulse (measured from the last positive zero crossing to the negative zero crossing).

#### B.4.3.7 Note for 14.3.1.3.5 on receiver common-mode rejection

For a stand-alone MAU, the receiver common-mode test may be performed with a jitterless  $E_s$ , so that the DI circuit should have no more than 4.0 ns of edge jitter.

For an integrated MAU, the common-mode test is performed with an  $E_s$  that has zero crossing jitter up to 11 ns from the ideal.

## B.5 10BASE-F

### B.5.1 System jitter budget

The jitter budgets for 10BASE-FP, 10BASE-FB, and 10BASE-FL are apportioned as shown in Table B–2.

**Table B–2—System jitter budgets**

Encoder	10BASE-FP	10BASE-FB	10BASE-FL
Encoder	0.5	0.5	0.5
AUI Cable including SNR (DO Pair)	1.5	N/A	1.5
MAU DO Receiver (10BASE-FP only)	2.0	N/A	N/A
10BASE-FP total at retiming	4.0	N/A	N/A
Subtotal (10BASE-FP Retimes)	0.0	0.5	2.0
Transmitter*	2.0	4.0	4.5
Subtotal (at the MDI)	2.0	4.5	6.5
Fiber optic medium	0.0	0.0	0.0
10BASE-FP Passive Star	0.0	N/A	N/A
Fiber optic medium (10BASE-FP return)	0.0	N/A	N/A
Receiver**	1.0	2.0	8.5
10BASE-FP total at retiming	3.0	N/A	N/A
Subtotal (10BASE-FP Retimes)	0.0	6.5	15.0
Unallocated	8.5	10.0	0.0
MAU DI Transmitter (10BASE-FP only)	6.5	N/A	N/A
AUI cable incl-SNR (DI Pair)	1.5	N/A	1.5
Total	16.5 ns	16.5 ns	16.5 ns
*Includes jitter plus duty cycle distortion.			
** 10BASE-FL figure includes MAU DI Transmitter jitter allocation.			

### B.5.2 10BASE-FP fiber optic segment loss budget

The 10BASE-FP MDI optical parameters specified in 15.2.1 and 15.2.2 have been selected to guarantee operation using a properly specified system of up to 500 m radius segment. This annex illustrates how the

loss budget may be allocated to star, optical fiber, and patch panel connectors, including examples at 100 m and 500 m radius.

The allowed system attenuation values are determined by the average transmit and receive power ranges specified in Table 15–1. The average optical power launched into a 62.5  $\mu\text{m}$  fiber must be greater than  $-15$  dBm and less than  $-11$  dBm. (This includes any launch power variation and source degradation.) Receiver operation is specified for average received power greater than  $-41$  dBm and less than  $-27$  dBm. Thus the maximum attenuation allowed for optical plant, including star, is 26 dB, and the minimum allowed attenuation is 16 dB.

This attenuation can be allocated between the star, fiber optic cable, and patch panel connectors in any manner as long as the maximum and minimum losses are within the limits stated in Table B–3. Note that the 10BASE-FP Star insertion loss includes the loss of one optical connector pair as specified in 16.5.2.1.

**Table B–3—10BASE-FP fiber optic segment loss budget**

Item	Min (dB)	Max (dB)
Star	16	20
Fiber and connectors	0	6
Totals	16	26

*Example 1:* For a 500 m radius segment (1 km MDI to MDI) of 3.75 dB/km (measured at 850 nm) optical fiber and a connector system with a maximum loss of 2 dB, the worst-case optical fiber and connector loss would be 5.75 dB. This would fall within the 6 dB limit, and result in a worst-case margin of 0.25 dB.

*Example 2:* A horizontal structured building wiring system (e.g., as detailed in ANSI/TIA/EIA-568-A-1995) of 100 m from the wiring closet to the desk top (100 m radius segment, 200 m MDI to MDI) of 3.75 dB/km optical fiber would have a loss of 0.75 dB. With four connector pairs in the path from MDI to MDI (wall plate, patch panel, patch panel, wall plate [see Figure 15–2]) and one connector pair at the 10BASE-FP Star (the other star connector pair is already included in the star loss [see 16.5.2.1]), and using a worst-case loss of 1 dB for each connector pair, the worst-case optical fiber and connector loss would be 5.75 dB. This would fall within the 6 dB limit, and would result in a worst-case margin of 0.25 dB.

In addition to these loss budgets, the overall system return loss must be greater than 27 dB. The return loss is the ratio of the desired signal to all undesired, multiple reflected signals, observed at a 10BASE-FP MAU MDI. Use of connectors with less return loss than specified in 15.3.2.2 as well as use of more than two patch panels on each side of the star is permitted, as long as the overall system return loss requirement is met.

The 8.0 dB differential flux budget (16.3.4.2) can be allocated as shown in Table B–4.

**Table B–4—Eight decibel differential flux budget**

Contribution	(dB)
Variation at Star Input due to combined effects	4.8
1/2 star connector	0.5
Star including 1/2 connector	2.5
Wavelength in ORD leg	0.2
Total	8.0



Each of these contributions to the differential budget is a measurable quantity. For example, the variation in the optical power at the star input due to combined effects of launch power, LED lifetime degradation, connectors, distance from 10BASE-FP MAU to Star, and wavelength of transmitter can be measured at the star input port. Also, star differential loss measurement is described in 16.5.2.2.

## **Annex C**

(informative)

### **State diagram, MAC sublayer**

This annex was deleted by IEEE Std 802.3x-1997 and IEEE Std 802.3y-1997.

## Annex D

(informative)

### Application context, selected medium specifications

#### D.1 Introduction

This annex provides general guidance, to both the design engineer and the eventual user of specific product implementations, on what particular clauses of the ISO/IEC 8802-3 International Standard might be considered useful for different application environments. It is to be emphasized that the material in this annex is very general, as the standard specifications are intended to be relatively application-independent. Nevertheless, certain specifications may apply more to one application environment than another. What follows are brief descriptions of application environments and lists of those generic parameters of the Physical Layer specifications thought to be useful in relating a general set of user requirements to a specific standard specification and its related medium. *Once a basic relationship is identified, the reader is directed to a specific clause of the standard for detailed design specifications.*

#### D.2 Type 10BASE5 applications

One of the major arenas for local area networks is the interconnection of work stations throughout a large department or single building. The ability to handle all kinds of message traffic at relatively high data rates among a large set of work stations are typical characteristics of these environments. Usually the basic interconnection trunk cable is installed and left in place permanently or for extended periods while work station placement may shift from time to time. The Type 10BASE5 specification provides the primary baseband backbone for intraplant CSMA/CD interconnections. Clause 7 and Clause 8 of the standard provide detailed specifications for the Physical Layers associated with Type 10BASE5 environments. The generic Physical Layer parameters are as follows:

Maximum unrepeated cable segment	500 m
Maximum number of MAUs per segment	100
Connector type	Type N or coaxial “tap”
Breakdown voltage, MAU function	250 V ac rms
MTBF	1 million hours
Total Segment Resistance	5 $\Omega$
MAU separation	2.5 m
Connection shunt capacitance	4 pF
AUI functionality	DO, DI, CI, (CO optional)

#### D.3 Type 10BASE2 applications

Another major arena for local area networks is the interconnection of work stations throughout a small department or work area. The ability to handle all kinds of message traffic at relatively high data rates among a selected set of locally clustered work stations are the typical characteristics of these environments. In addition, the basic interconnection trunk cable is likely to be moved frequently by the local users of the equipment to suit evolving needs. The Type 10BASE2 specification provides an interconnection schema that complements the Type 10BASE5 backbone in a hierarchical manner for intradepartment or work area CSMA/CD interconnections. Clause 7 and Clause 10 of the standard provide detailed specifications for the

Physical Layers associated with Type 10BASE2 environments. The generic Physical Layer parameters are as follows:

Maximum unrepeaters cable segment	185 m
Maximum number of MAUs per segment	30
Connector type	Type BNC “T”
Breakdown voltage, MAU function	500 V ac rms
MTBF	100 000 hours
Total Segment Resistance	10 $\Omega$
MAU separation	0.5 m
Connection shunt capacitance	8 pF
AUI functionality	DO, DI, CI

## D.4 Type FOIRL and 10BASE-F applications; alternative fiber optic medium applications

### D.4.1 Alternative fiber types

Table D–1 provides a listing of other fiber types that may be used in an FOIRL or a 10BASE-F Cable Link Segment. These fiber types have not been studied, and details for their use are not provided for in the main body of the standard. Therefore, using these fiber types may reduce the maximum achievable distance.

**Table D–1—Alternative fiber types**

Nominal Core diameter ( $\mu\text{m}$ ) IEC 60793-2:1992	Nominal cladding diameter ( $\mu\text{m}$ ) IEC 60793-2:1992	Nominal Numerical aperture IEC 60793-2:1992
50	125	0.2
50	125	0.21
50	125	0.22
85	125	0.26
100	140	0.29

#### D.4.1.1 Theoretical coupling losses

The body of the standard references a single fiber type to facilitate interoperability and conformance testing; however, other fiber types may also be used. The use of an alternate fiber type with a particular implementation may have the following consequences. At the transmit MDI, more or less light may be launched into the fiber, depending on whether the optics are optimized for a core size and a numerical aperture (NA) that are smaller or larger than that of the alternate fiber size. At the receive MDI, the sensitivity may be increased or decreased depending on the optimization of the collecting optics. Table D–2 summarizes the potential effects of the use of alternate fiber sizes and provides the loss budget remaining for cable plant attenuation. All adjustments are relative to an implementation using the minimum diameter and NA 62.5  $\mu\text{m}$  core fiber as specified in IEC 60793-2:1992, Type A1b, Category  $\leq 3.5$  dB/km. This cable plant has a loss budget of 9 dB for FOIRL segments and 12.5 dB for 10BASE-FL and 10BASE-FB link segments.

The worst-case loss budget in Table D–2 is calculated on the assumption that the transmitter and receiver core diameter and NA are 62.5  $\mu\text{m}$  and 0.275, respectively. Launching into a smaller core diameter or NA will incur a loss. Launching into a larger core diameter or NA will not result in a gain.

Similarly, receiving from a larger core diameter or NA incurs a loss, but receiving from smaller core diameter or NA provides no gain.

The values for transmit powers assume a worst-case condition that no additional power is launched into an increased core diameter and NA link fiber when referred to the 62.5  $\mu\text{m}$  core fiber. This assumption is valid for underfilled launch conditions such as may occur from a MAU containing a pigtailed or laser emitter.

**Table D–2—Worst-case loss budget**

Fiber type	Transmit loss (dB)	Receive loss (dB)	Loss budget remaining (dB)	
			FOIRL	10BASE-FB/L
50 $\mu\text{m}$ /NA=0.20	5.7	0	3.3	6.8
50 $\mu\text{m}$ /NA=0.21	5.2	0	3.8	7.3
50 $\mu\text{m}$ /NA=0.22	4.8	0	4.2	7.7
85 $\mu\text{m}$ /NA=0.26	1.6	2.6	4.8	8.3
100 $\mu\text{m}$ /NA=0.29	0.5	4.5	4.0	7.5

#### D.4.1.2 Maximum launch power

When large core diameter and NA launch conditions are used in conjunction with a launch fiber of larger core diameter and NA than the 62.5  $\mu\text{m}$  reference, significantly greater launch power can occur. For example, this is typically the case with wide area surface emitter LED devices that are directly aligned with a fiber in a device mount header.

Table D–3 summarizes the maximum launch power into fibers with larger core diameters than 62.5  $\mu\text{m}$  and the corresponding excess power that can result with a receiver utilizing all the optical power from the fiber.

**Table D–3—Worst-case launch power**

Fiber type	Maximum transmit power (dBm)	Maximum excess power (dBm)
85 $\mu\text{m}$ /NA=0.26	–6.1	2.9
100 $\mu\text{m}$ /NA=0.29	–3.8	5.2

In this case, sufficient attenuation should be installed in the link segment to ensure that for FOIRL segments the peak received optical power does not exceed –9 dBm, and for 10BASE-F segments the average received optical power does not exceed the appropriate optical Receive Average Power (Max) in Table 15–1.

## D.4.2 Type 10BASE-FP applications using 50/125 $\mu\text{m}$ fiber

It is recognized that, in some cases, designers are constrained to use fiber sizes other than 62.5/125  $\mu\text{m}$  in LAN designs. Such LAN designs are beyond the scope of this standard but can operate properly if optical power and loss budgets are adjusted to compensate for the different fiber characteristics. The following guidance is provided for system implementors who are constrained to design LANs with the 50/125  $\mu\text{m}$  fiber described in D.4.1.

### WARNING

Interoperability of nonconforming implementations cannot be ensured. It is the responsibility of the designer(s) of nonconforming implementation(s) to assure LAN operation. The following is only advisory information for implementations outside the scope of this standard.

### D.4.2.1 Coupled transmit power

As shown in D.4.1, reduction of coupled power introduces the greatest difference between LANs using 62.5/125  $\mu\text{m}$  and those using 50/125  $\mu\text{m}$  fiber. Typically, for an emitter technology that produces a uniform, over-filled launch condition, this difference will be 3.5 dB. Implementors of 50/125  $\mu\text{m}$  systems may choose to deal with this by trying one of the following alternatives:

- a) Selecting an emitter technology with coupled power that is less susceptible to variation with fiber size, or
- b) Increasing receiver sensitivity and dynamic range, or
- c) Reducing the star coupler loss to compensate for the reduction in coupled transmit power. This may be accomplished by reducing the number of ports on the star coupler, or
- d) Reducing the connector losses in the system, either by reducing the number of in-line connectors or reducing the loss per connector.

### D.4.2.2 Star coupler loss

Also in accordance with D.4.1, the transmission loss of 50/125  $\mu\text{m}$  star couplers may be as much as 1 dB greater than their 62.5/125  $\mu\text{m}$  counterparts. Implementors of 50/125  $\mu\text{m}$  systems may choose to deal with this by trying one of the following alternatives:

- a) Procurement—specification of coupler loss characteristics to be the same as those shown for 62.5/125  $\mu\text{m}$  star couplers, per 16.5, or
- b) Compensation—all items shown in D.4.2.1 a) to d) may be used to compensate for an increase in coupler loss.

For example, a passive-star coupler (with connectors) with 33 ports typically has the following losses:

Contributor	Loss (dB)
Splitting	-15
Connector (1)	-1
Excess	0 to -4
Total	-16 to -20

If, in a LAN that used 50/125  $\mu\text{m}$  fiber, the maximum allowable number of ports per passive-star coupler was reduced to 17, the appropriate losses would be as follows:

Contributor	Loss (dB)
Splitting:	-12
Connector (1):	-1
Excess:	0 to -3
Total:	-13 to -16

The 3.5 dB lost to the MDI OTD would then be recovered allowing this “reduced nodes” LAN to still operate at the proposed maximum of 500 m MAU to the star.

It should be noted that the MAU parameters remain unchanged.

#### D.4.2.3 Collision detection

Reliable collision detection requires that designers of systems using nonconforming fiber optic cable ensure that the optical power levels of all possible colliding signals on the LAN differ at the mixing element (passive-star coupler) by no more than that specified in 16.3.4.2. This requires that  $10 \times \text{abs}(\log((P_{Ti} - L_{Ti} - U_{Ti})/(P_{Tj} - L_{Tj} - U_{Tj}))) \leq$  that specified in 16.3.4.2.

for all  $i$  not equal  $j$ , and

where

- $P_{Tn}$  is coupled optical transmit power, MAU  $n$
- $L_{Tn}$  is optical cable and connector and transmit fiber loss, from MAU  $n$  to star input port  $m$
- $U_{Tm}$  is input port uniformity, port  $m$

### D.5 10BASE-T use of cabling systems with a nominal differential characteristic impedance of 120 $\Omega$

Clause 14 specifies the use of 100  $\Omega$  link segments. This subclause specifies the conditions for the use of cabling with a nominal characteristic impedance of 120  $\Omega$  by 10BASE-T conformant stations.

The use of cables with a characteristic impedance outside the range specified in 14.4.2.2 will generally increase the mismatching effects in the link components, inducing additional jitter in the received signal.

In particular, the use of a homogeneous link segment having a characteristic impedance of 120  $\Omega \pm 15 \Omega$  over the frequency band 1 to 16 MHz may add from 0.15 ns (maximum-length segment) up to 0.63 ns (short-length segment) of additional jitter to the signal at the input of the receiver.

Consequently, in order to keep the overall jitter budget at the same value as for a 100  $\Omega$  link segment when using a 120  $\Omega$  link segment, the following modifications to the specifications of 14.4 apply:

- a) The maximum medium timing jitter specified in 14.4.2.3 for a simplex link segment is increased from 5 ns to 5.5 ns.

- b) The NEXT loss values specified in 14.4.3 are increased by 3 dB, i.e., the applicable formulas are replaced by the following:
- 1) in 14.4.3.1.1 for 25-pair cables/binder groups:  $33-15 \log_{10}(f/10)$  dB.
  - 2) in 14.4.3.1.2 for 4-pair cables:  $29-15 \log_{10}(f/10)$  dB.
  - 3) in 14.4.3.2 for MDNEXT:  $26-15 \log_{10}(f/10)$  dB.

NOTE—In addition to the case of 120  $\Omega$  homogeneous link segments, the above figures encompass the case where 100  $\Omega$  terminal cords are used in conjunction with 120  $\Omega$  premises cabling. This configuration results in adding up to 0.5 ns of jitter for a maximum-length segment (instead of 0.15 ns) and up to 1.3 ns for a short-length segment (instead of 0.63 ns).

The use of 100  $\Omega$  cords at any intermediate cross-connects on 120  $\Omega$  links as well as the use of cords with a characteristic impedance of  $120 \Omega \pm 15 \Omega$  in conjunction with 100  $\Omega \pm 15 \Omega$  premises cabling is not allowed since it would result in worst-case jitter greater than that allowed in the standard.

## D.6 10BASE-T use of cabling systems with a nominal differential characteristic impedance of 150 $\Omega$

This subclause outlines the philosophy and methodology for allowing 10BASE-T stations to support transmission on 150  $\Omega$  balanced STP cabling, as specified by ISO/IEC 11801:1995, Clause 8, with the use of impedance matching transformers.

The 10BASE-T specification was designed to support Manchester signaling over a link segment consisting of 100  $\Omega$  cabling system. The MAU link interface specifications were designed to ensure that jitter due to impedance discontinuities were minimized as specified in 14.4.2.3. In theory and in practice, a 150  $\Omega$  cabling system may be used to provide the link segment function provided the proper impedance match (100  $\Omega$ ) with the MAU over the frequency range of interest as specified in 14.4, and the resultant transmission characteristics of the cabling system used to provide the link segment function meet or exceed those specified in 14.4. Therefore, to ensure the jitter specification of 14.4.2.3 and the jitter budget of B.4.1 are met, the following approach is recommended when using 150  $\Omega$  balanced STP cabling (as specified in ISO/IEC 11801:1995):

- a) The 150  $\Omega$  section included in the link segment shown in Figure D-1 meets the specifications of ISO/IEC 11801:1995, 7.2.

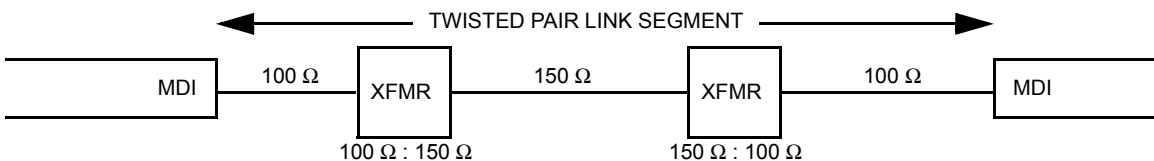
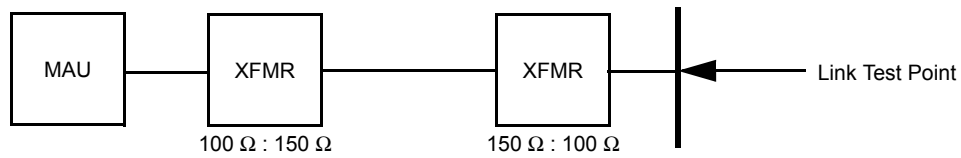


Figure D-1—Link segment incorporating 150  $\Omega$  cable section



- b) The link segment, including impedance matching transformers as shown in Figure D–2, meets all applicable specifications of 14.4.
- c) A link test point is shown in Figure D–2. The transformers shown are the same as the ones shown in Figure D–1. The attaching cables between the MAU and the link test point should be the minimum required to attach the components. As tested in this configuration, the MAU transmitter requirements meet all applicable requirements for the MAU as specified in Clause 14, except for signal levels which may be up to 1.0 dB lower than that specified there.

NOTE—This 1.0 dB (0.5 dB per transformer) effectively requires the attenuation of the 150  $\Omega$  cable section of the twisted-pair link segment (see Figure D–1) to be less than or equal to 10.5 dB in order to meet the requirements of 14.4.2.



**Figure D–2—Link test point for 150  $\Omega$  cabling**

## **Annex E**

(informative)

### **Receiver wavelength design considerations (FOIRL)**

The center wavelength of the optical source emission is specified in 9.9.4.1.1 to be between 790 nm and 860 nm. Although these limits are acceptable, it is currently recognized, through the examination of manufacturers' current data, that greater choices of emitters can be obtained by extending the allowable wavelength to 910 nm.

An upper limit of 910 nm allows the selection of devices nominally centered at a lower wavelength, for example, 880 nm. This allows a tolerance for manufacturing variations, for example,  $\pm 20$  nm, and a tolerance for an operating temperature range (typically,  $0.3$  nm/ $^{\circ}$ C).

It is anticipated that future fiber optic applications including Local Area Networks will use the 910 nm upper limit for first window systems. It is therefore recommended that implementors specify receiver sensitivity over a center wavelength range from 790 nm to 910 nm.

## Annex F

(normative)

### Additional attributes required for systems

#### F.1 Introduction

During the development of Repeater Management, some attributes and operations were identified as items that were necessary to fill out the management of a complete intermediate system such as a repeater. These items are generic in the sense that they are required for managed systems in general. They are not normally specified as attributes of the lower layers. In repeater management, the entire system is at the lowest layers so there is no other group to turn to for systems management. The following items are defined to aid in the completeness of this standard, although it is recognized that they are outside the bounds of the definition area for a layer1/2 device.

##### F.1.1 Scope

This annex defines additional managed objects and attributes that have been identified by the IEEE 802.3 Repeater Management Task Force as being necessary to the management of an IEEE 802.3 repeater. These objects and attributes, while necessary to the management of an IEEE 802.3 repeater, are not specifically related to the CSMA/CD access method or to Clause 9 repeaters; rather, they are objects and attributes that are appropriate for any managed system.

This annex does not necessarily define the complete set of generic objects and attributes required to support a managed system. It contains only those objects and attributes that were identified in the process of developing the repeater management standard and were identified as not being uniquely appropriate to a CSMA/CD layer management standard.

When a generic systems management standard is available that is appropriate for managed systems of the complexity of a repeater, it is expected that this portion of the standard will no longer be appropriate and will be deprecated.

#### F.2 Objects/Attributes/Actions/Notifications

##### F.2.1 TimeSinceSystemReset attribute

<b>aTimeSinceSystemReset</b>	<b>ATTRIBUTE</b>
DERIVED FROM	AttributeModule.ResettableCounter32;
BEHAVIOUR	bTimeSinceSystemReset;
REGISTERED AS	{iso(1) member-body(2) us(840) 802dot3(10006) repeaterMgt(19) attribute(7) sysResetTime(47)};

**bTimeSinceSystemReset**                      **BEHAVIOUR**  
DEFINED AS                      The time in tens of milliseconds since the last time that the system including network management was reset. This may have been caused by ResetSystemAction or other means. This counter has a value of 0 when initialized.

Though the count is reported in tens of milliseconds, the required resolution is to the nearest 100 ms. The clocking source for the counter shall be accurate to within 1% throughout the full counting range.;

NOTE—The approximate minimum time for counter rollover is 497 days.

## F.2.2 RepeaterResetTimeStamp attribute

**aRepeaterResetTimeStamp**                      **ATTRIBUTE**  
WITH ATTRIBUTE SYNTAX                      AttributeModule.Integer32;  
BEHAVIOUR                                      bRepeaterResetTimeStamp;  
REGISTERED AS                      {iso(1) member-body(2) us(840) 802dot3(10006) repeaterMgt(19) attribute(7) repeaterResetTimeStamp(48)};

**bRepeaterResetTimeStamp**                      **BEHAVIOUR**  
DEFINED AS                      Not a counter, this attribute provides the value of aTimeSinceSystemReset when the repeater was last reset. This value is recorded whenever the repeater enters the START state of Figure 9–2 in the 802.3 repeater standard. This value may never be greater than aTimeSinceSystemReset.;

## F.2.3 ResetSystemAction action

**acResetSystemAction**                              **ACTION**  
BEHAVIOUR                                      acResetSystem;  
MODE    CONFIRMED;  
REGISTERED AS                      {iso(1) member-body(2) us(840) 802dot3(10006) repeaterMgt(19) action(9) resetSystem(49)};

**acResetSystem**                                      **BEHAVIOUR**  
DEFINED AS                      This action initializes the resettable management counters of the system and also of all contained objects. The value of non-resettable counters may change as a result of this action.;

NOTE—This action may result in the loss of packets.

## **Annex G**

(normative)

### **Additional material required for conformance testing**

#### **G.1 Introduction**

This material was generated during the development of Clause 19. It was felt that it was required to support the development of conformance test material that was not included in the charter of the development of the original repeater management standard.

##### **G.1.1 Material in support of the aDataRateMismatches attribute**

A vendor submitting equipment for conformance testing under Clause 19 shall provide minimum frequency difference data (two values) such that a test can be done for exertion and another test can be done for non-exertion of the aDataRateMismatch attribute (see 19.2.6.2).

## Annex H

(normative)

### GDMO specifications for CSMA/CD managed objects

#### H.1 Use of MAC and PLS Sublayer Management Definitions with CMIS/CMIP and ISO/IEC 15802-2: 1995 Management Protocols

NOTE—The arcs (that is, object identifier values) defined in Annex 30A deprecate the arcs previously defined in H.1 (Layer Management), H.2 (Repeater Management), and H.3 (MAU Management). See IEEE Std 802.1F-1993, Annex C4.

This annex clause formally defines the protocol encodings for CMIP and ISO/IEC 15802-2: 1995 for the DTE Management objects using the templates specified in ISO/IEC 10165-4: 1992.

Each attribute definition in this clause references directly by means of the WITH ATTRIBUTE SYNTAX construct or indirectly by means of the DERIVED FROM construct an ASN.1 type or subtype that defines the attribute's type and range. Those ASN.1 types and subtypes defined exclusively for CSMA/CD Management are included in H.4.

##### H.1.1 DTE MAC sublayer managed object class

###### H.1.1.1 DTE MAC sublayer formal definition

<p><b>oMAC-entity</b> DERIVED FROM</p> <p>CHARACTERIZED BY</p> <p style="padding-left: 40px;"><b>pBasic</b></p> <p style="padding-left: 80px;">ATTRIBUTES</p> <p style="padding-left: 80px;">ACTIONS</p> <p style="text-align: center;">;</p> <p>;</p> <p>CONDITIONAL PACKAGES</p> <p style="padding-left: 40px;"><b>pMandatory</b></p> <p style="padding-left: 80px;">ATTRIBUTES</p> <p style="padding-left: 80px;">REGISTERED AS</p> <p style="padding-left: 80px;">PRESENT IF</p> <p style="padding-left: 40px;"><b>pRecommended</b></p> <p style="padding-left: 80px;">ATTRIBUTES</p>	<p><b>MANAGED OBJECT CLASS</b> “CCITT Rec. X.721 (1992)   ISO/IEC 10165-2 : 1992”:top;</p> <p><b>PACKAGE</b></p> <p>aMACID GET;</p> <p>acInitializeMAC;</p> <p><b>PACKAGE</b></p> <p>aFramesTransmittedOK GET,</p> <p>aSingleCollisionFrames GET,</p> <p>aMultipleCollisionFrames GET,</p> <p>aFramesReceivedOK GET,</p> <p>aFrameCheckSequenceErrors GET,</p> <p>aAlignmentErrors GET;</p> <p>{iso(1) member-body(2) us(840) 802dot3(10006) csmadtemgt(5) package(4) macMandatoryPkg(103)};</p> <p>Conformance to DTE Management is desired.;</p> <p><b>PACKAGE</b></p> <p>aOctetsTransmittedOK GET,</p> <p>aFramesWithDeferredXmissions GET,</p> <p>aLateCollisions GET,</p> <p>aFramesAbortedDueToXSColls GET,</p> <p>aFramesLostDueToIntMACXmitError GET,</p>
---	--

	aCarrierSenseErrors	GET,
	aOctetsReceivedOK	GET,
	aFramesLostDueToIntMACRcvError	GET,
	aPromiscuousStatus	GET-SET,
	aReadMulticastAddressList	GET;
ACTIONS	acAddGroupAddress,	
	acDeleteGroupAddress;	
REGISTERED AS	{iso(1) member-body(2) us(840) 802dot3(10006)	
	csmadtemgt(5) package(4)	
	macRecommendedPkg(104)};	
PRESENT IF	The Recommended Package is implemented.;	
<b>pOptional</b>	<b>PACKAGE</b>	
ATTRIBUTES	aMulticastFramesXmittedOK	GET,
	aBroadcastFramesXmittedOK	GET,
	aMulticastFramesReceivedOK	GET,
	aBroadcastFramesReceivedOK	GET,
	aInRangeLengthErrors	GET,
	aOutOfRangeLengthField	GET,
	aFrameTooLongErrors	GET,
	aMACEnableStatus	GET-SET,
	aTransmitEnableStatus	GET-SET,
	aMulticastReceiveStatus	GET-SET,
	aReadWriteMACAddress	GET-SET;
ACTIONS	acExecuteSelfTest;	
REGISTERED AS	{iso(1) member-body(2) us(840) 802dot3(10006)	
	csmadtemgt(5) package(4) optionalPkg(105)};	
PRESENT IF	The Optional Package and the Recommended Package is	
	implemented.;	
<b>pArray</b>	<b>PACKAGE</b>	
ATTRIBUTES	aCollisionFrames	GET;
REGISTERED AS	{iso(1) member-body(2) us(840) 802dot3(10006)	
	csmadtemgt(5) package(4) arrayPkg(106)};	
PRESENT IF	The Array Package and the Recommended Package are	
	implemented.;	
<b>pExcessiveDeferral</b>	<b>PACKAGE</b>	
ATTRIBUTES	aFramesWithExcessiveDeferral	GET;
REGISTERED AS	{iso(1) member-body(2) us(840) 802dot3(10006)	
	csmadtemgt(5) package(4)	
	excessiveDeferralPkg(107)};	
PRESENT IF	The ExcessiveDeferral Package and the Recommended	
	Package are implemented.;	
REGISTERED AS	{iso(1) member-body(2) us(840) 802dot3(10006) csmadtemgt(5)	
	managedObjectClass(3) macObjectClass(101)};	
<b>nbMACName</b>	<b>NAME BINDING</b>	
SUBORDINATE OBJECT CLASS	oMAC-entity;	
NAMED BY SUPERIOR OBJECT CLASS	“ISO/IEC 10165-2”:system;	
WITH ATTRIBUTE	aMACID;	
REGISTERED AS	{iso(1) member-body(2) us(840) 802dot3(10006) csmadtemgt(5)	
	nameBinding(6) macName(109)};	
<b>nbMACMonitor</b>	<b>NAME BINDING</b>	
SUBORDINATE OBJECT CLASS	“IEEE802.1F”:ewmaMetricMonitor;	

NAMED BY SUPERIOR OBJECT CLASS  
 WITH ATTRIBUTE  
     **CREATE**  
     **DELETE**  
 REGISTERED AS

“ISO/IEC 10165-2”:system;  
 aScannerId;  
**WITH-AUTOMATIC-INSTANCE-NAMING;**  
**ONLY-IF-NO-CONTAINED-OBJECTS;**  
 {iso(1) member-body(2) us(840) 802dot3(10006) csmadtemgt(5)  
 nameBinding(6) macMonitor(110)};

#### H.1.1.2 DTE MAC sublayer attributes

<b>aMACID</b>	<b>ATTRIBUTE</b>
WITH ATTRIBUTE SYNTAX	IEEE802Dot3-MgmtAttributeModule.
MATCHES FOR	OneOfName;
BEHAVIOUR	EQUALITY;
REGISTERED AS	bMACID;
	{iso(1) member-body(2) us(840) 802dot3(10006) csmadtemgt(5) attribute(7) macID(114)};
<b>bMACID</b>	<b>BEHAVIOUR</b>
DEFINED AS	See “BEHAVIOUR DEFINED AS” in 5.2.2.1.1.;
<b>aFramesTransmittedOK</b>	<b>ATTRIBUTE</b>
DERIVED FROM	aLMCounter;
BEHAVIOUR	bFramesTransmittedOK;
REGISTERED AS	{iso(1) member-body(2) us(840) 802dot3(10006) csmadtemgt(5) attribute(7) framesTransmittedOK(115)};
<b>bFramesTransmittedOK</b>	<b>BEHAVIOUR</b>
DEFINED AS	See “BEHAVIOUR DEFINED AS” in 5.2.2.1.2.;
	NOTE 1—The approximate minimum time between counter rollovers is 80 h.;
	NOTE 2—This maps to framesSent (of the mandatory macPackage) in ISO/IEC 10742: 1994.;
<b>aSingleCollisionFrames</b>	<b>ATTRIBUTE</b>
DERIVED FROM	aLMCounter;
BEHAVIOUR	bSingleCollisionFrames;
REGISTERED AS	{iso(1) member-body(2) us(840) 802dot3(10006) csmadtemgt(5) attribute(7) singleCollisionFrames(116)};
<b>bSingleCollisionFrames</b>	<b>BEHAVIOUR</b>
DEFINED AS	See “BEHAVIOUR DEFINED AS” in 5.2.2.1.3.;
	NOTE—The approximate minimum time between counter rollovers is 103 h.;
<b>aMultipleCollisionFrames</b>	<b>ATTRIBUTE</b>
DERIVED FROM	aLMCounter;
BEHAVIOUR	bMultipleCollisionFrames;



REGISTERED AS	{iso(1) member-body(2) us(840) 802dot3(10006) csmadtemgt(5) attribute(7) multipleCollisionFrames(117)};
<b>bMultipleCollisionFrames</b>	<b>BEHAVIOUR</b>
DEFINED AS	See “BEHAVIOUR DEFINED AS” in 5.2.2.1.4.;
	NOTE—The approximate minimum time between counter rollovers is 125 h.;
<b>aFramesReceivedOK</b>	<b>ATTRIBUTE</b>
DERIVED FROM	aLMCounter;
BEHAVIOUR	bFramesReceivedOK;
REGISTERED AS	{iso(1) member-body(2) us(840) 802dot3(10006) csmadtemgt(5) attribute(7) framesReceivedOK(118)};
<b>bFramesReceivedOK</b>	<b>BEHAVIOUR</b>
DEFINED AS	See “BEHAVIOUR DEFINED AS” in 5.2.2.1.5.;
	NOTE 1—The approximate minimum time between counter rollovers is 80 h.;
	NOTE 2—This maps to framesReceived (of the mandatory macPackage) in ISO/ IEC 10742: 1994.;
<b>aFrameCheckSequenceErrors</b>	<b>ATTRIBUTE</b>
DERIVED FROM	aLMCounter;
BEHAVIOUR	bFrameCheckSequenceErrors;
REGISTERED AS	{iso(1) member-body(2) us(840) 802dot3(10006) csmadtemgt(5) attribute(7) frameCheckSequenceErrors(119)};
<b>bFrameCheckSequenceErrors</b>	<b>BEHAVIOUR</b>
DEFINED AS	See “BEHAVIOUR DEFINED AS” in 5.2.2.1.6.;
	NOTE—The approximate minimum time between counter rollovers is 80 h.;
<b>aAlignmentErrors</b>	<b>ATTRIBUTE</b>
DERIVED FROM	aLMCounter;
BEHAVIOUR	bAlignmentErrors;
REGISTERED AS	{iso(1) member-body(2) us(840) 802dot3(10006) csmadtemgt(5) attribute(7) alignmentErrors(120)};
<b>bAlignmentErrors</b>	<b>BEHAVIOUR</b>
DEFINED AS	See “BEHAVIOUR DEFINED AS” in 5.2.2.1.7.;
	NOTE—The approximate minimum time between counter rollovers is 80 h.;
<b>aOctetsTransmittedOK</b>	<b>ATTRIBUTE</b>
DERIVED FROM	aLMCounter;
BEHAVIOUR	bOctetsTransmittedOK;
REGISTERED AS	{iso(1) member-body(2) us(840) 802dot3(10006) csmadtemgt(5) attribute(7) octetsTransmittedOK(121)};
<b>bOctetsTransmittedOK</b>	<b>BEHAVIOUR</b>
DEFINED AS	See “BEHAVIOUR DEFINED AS” in 5.2.2.1.8.;
	NOTE 1—The approximate minimum time between counter rollovers is 58 min.
	NOTE 2—This maps to octetsSent (of the mandatory macPackage) in ISO/IEC 10742: 1994.;
<b>aFramesWithDeferredXmissions</b>	<b>ATTRIBUTE</b>

DERIVED FROM BEHAVIOUR REGISTERED AS	aLMCounter; bFramesWithDeferredXmissions; {iso(1) member-body(2) us(840) 802dot3(10006) csmadtemgt(5) attribute(7) framesWithDeferredXmissions(122)};
<b>bFramesWithDeferredXmissions</b> DEFINED AS	<b>BEHAVIOUR</b> See “BEHAVIOUR DEFINED AS” in 5.2.2.1.9.;  NOTE—The approximate minimum time between counter rollovers is 103 h.;
<b>aLateCollisions</b> DERIVED FROM BEHAVIOUR REGISTERED AS	<b>ATTRIBUTE</b> aLMCounter; bLateCollisions; {iso(1) member-body(2) us(840) 802dot3(10006) csmadtemgt(5) attribute(7) lateCollisions(123)};
<b>bLateCollisions</b> DEFINED AS	<b>BEHAVIOUR</b> See “BEHAVIOUR DEFINED AS” in 5.2.2.1.10.;  NOTE—The approximate minimum time between counter rollovers is 80 h.;
<b>aFramesAbortedDueToXSColls</b> DERIVED FROM BEHAVIOUR REGISTERED AS	<b>ATTRIBUTE</b> aLMCounter; bFramesAbortedDueToXSColls; {iso(1) member-body(2) us(840) 802dot3(10006) csmadtemgt(5) attribute(7) framesAbortedDueToXSColls(124)};
<b>bFramesAbortedDueToXSColls</b> DEFINED AS	<b>BEHAVIOUR</b> See “BEHAVIOUR DEFINED AS” in 5.2.2.1.11.;  NOTE—The approximate minimum time between counter rollovers is 53 days.;
<b>aFramesLostDueToIntMACXmitError</b> DERIVED FROM BEHAVIOUR REGISTERED AS	<b>ATTRIBUTE</b> aLMCounter; bFramesLostDueToIntMACXmitError; {iso(1) member-body(2) us(840) 802dot3(10006) csmadtemgt(5) attribute(7) framesLostDueToIntMACXmitError(125)};
<b>bFramesLostDueToIntMACXmitError</b> DEFINED AS	<b>BEHAVIOUR</b> See “BEHAVIOUR DEFINED AS” in 5.2.2.1.12.;  NOTE—The approximate minimum time between counter rollovers is 16 h.;
<b>aCarrierSenseErrors</b> DERIVED FROM BEHAVIOUR REGISTERED AS	<b>ATTRIBUTE</b> aLMCounter; bCarrierSenseErrors; {iso(1) member-body(2) us(840) 802dot3(10006) csmadtemgt(5) attribute(7) carrierSenseErrors(126)};
<b>bCarrierSenseErrors</b> DEFINED AS	<b>BEHAVIOUR</b> See “BEHAVIOUR DEFINED AS” in 5.2.2.1.13.;  NOTE—The approximate minimum time between counter rollovers is 80 h.;
<b>aOctetsReceivedOK</b>	<b>ATTRIBUTE</b>

DERIVED FROM	aLMCounter;
BEHAVIOUR	bOctetsReceivedOK;
REGISTERED AS	{iso(1) member-body(2) us(840) 802dot3(10006) csmadtemgt(5) attribute(7) octetsReceivedOK(127)};
<b>bOctetsReceivedOK</b>	<b>BEHAVIOUR</b>
DEFINED AS	See “BEHAVIOUR DEFINED AS” in 5.2.2.1.14.;
	NOTE 1—The approximate minimum time between counter rollovers is 58 min.
	NOTE 2—This maps to octetsReceived (of the mandatory macPackage) in ISO/IEC 10742: 1994.;
<b>aFramesLostDueToIntMACRcvError</b>	<b>ATTRIBUTE</b>
DERIVED FROM	aLMCounter;
BEHAVIOUR	bFramesLostDueToIntMACRcvError;
REGISTERED AS	{iso(1) member-body(2) us(840) 802dot3(10006) csmadtemgt(5) attribute(7) framesLostDueToIntMACRcvError(128)};
<b>bFramesLostDueToIntMACRcvError</b>	<b>BEHAVIOUR</b>
DEFINED AS	See “BEHAVIOUR DEFINED AS” in 5.2.2.1.15.;
	NOTE—The approximate minimum time between counter rollovers is 80 h.;
<b>aPromiscuousStatus</b>	<b>ATTRIBUTE</b>
WITH ATTRIBUTE SYNTAX	IEEE802Dot3-MgmtAttributeModule. TrueFalse;
BEHAVIOUR	bPromiscuousStatus;
REGISTERED AS	{iso(1) member-body(2) us(840) 802dot3(10006) csmadtemgt(5) attribute(7) promiscuousStatus(129)};
<b>bPromiscuousStatus</b>	<b>BEHAVIOUR</b>
DEFINED AS	See “BEHAVIOUR DEFINED AS” in 5.2.2.1.16.;
<b>aReadMulticastAddressList</b>	<b>ATTRIBUTE</b>
WITH ATTRIBUTE SYNTAX	IEEE802Dot3-MgmtAttributeModule. MulticastAddressList
BEHAVIOUR	bReadMulticastAddressList;
REGISTERED AS	{iso(1) member-body(2) us(840) 802dot3(10006) csmadtemgt(5) attribute(7) readMulticastAddressList(130)};
<b>bReadMulticastAddressList</b>	<b>BEHAVIOUR</b>
DEFINED AS	See “BEHAVIOUR DEFINED AS” in 5.2.2.1.17.;
<b>aMulticastFramesXmittedOK</b>	<b>ATTRIBUTE</b>
DERIVED FROM	aLMCounter;
BEHAVIOUR	bMulticastFramesXmittedOK;
REGISTERED AS	{iso(1) member-body(2) us(840) 802dot3(10006) csmadtemgt(5) attribute(7) multicastFramesXmittedOK(131)};
<b>bMulticastFramesXmittedOK</b>	<b>BEHAVIOUR</b>
DEFINED AS	See “BEHAVIOUR DEFINED AS” in 5.2.2.1.18.;
	NOTE—The approximate minimum time between counter rollovers is 80 h.;

<b>aBroadcastFramesXmittedOK</b>	<b>ATTRIBUTE</b>
DERIVED FROM	aLMCounter;
BEHAVIOUR	bBroadcastFramesXmittedOK;
REGISTERED AS	{iso(1) member-body(2) us(840) 802dot3(10006) csmadtemgt(5) attribute(7) broadcastFramesXmittedOK(132)};
<b>bBroadcastFramesXmittedOK</b>	<b>BEHAVIOUR</b>
DEFINED AS	See “BEHAVIOUR DEFINED AS” in 5.2.2.1.19.;
	NOTE—The approximate minimum time between counter rollovers is 80 h.;
<b>aFramesWithExcessiveDeferral</b>	<b>ATTRIBUTE</b>
DERIVED FROM	aLMCounter;
BEHAVIOUR	bFramesWithExcessiveDeferral;
REGISTERED AS	{iso(1) member-body(2) us(840) 802dot3(10006) csmadtemgt(5) attribute(7) framesWithExcessiveDeferral(133)};
<b>bFramesWithExcessiveDeferral</b>	<b>BEHAVIOUR</b>
DEFINED AS	See “BEHAVIOUR DEFINED AS” in 5.2.2.1.20.;
	NOTE—The approximate minimum time between counter rollovers is 58 days.;
<b>aMulticastFramesReceivedOK</b>	<b>ATTRIBUTE</b>
DERIVED FROM	aLMCounter;
BEHAVIOUR	bMulticastFramesReceivedOK;
REGISTERED AS	{iso(1) member-body(2) us(840) 802dot3(10006) csmadtemgt(5) attribute(7) multicastFramesReceivedOK(134)};
<b>bMulticastFramesReceivedOK</b>	<b>BEHAVIOUR</b>
DEFINED AS	See “BEHAVIOUR DEFINED AS” in 5.2.2.1.21.;
	NOTE—The approximate minimum time between counter rollovers is 80 h.;
<b>aBroadcastFramesReceivedOK</b>	<b>ATTRIBUTE</b>
DERIVED FROM	aLMCounter;
BEHAVIOUR	bBroadcastFramesReceivedOK;
REGISTERED AS	{iso(1) member-body(2) us(840) 802dot3(10006) csmadtemgt(5) attribute(7) broadcastFramesReceivedOK(135)};
<b>bBroadcastFramesReceivedOK</b>	<b>BEHAVIOUR</b>
DEFINED AS	See “BEHAVIOUR DEFINED AS” in 5.2.2.1.22.;
	NOTE—The approximate minimum time between counter rollovers is 80 h.;
<b>aInRangeLengthErrors</b>	<b>ATTRIBUTE</b>
DERIVED FROM	aLMCounter;
BEHAVIOUR	bInRangeLengthErrors;
REGISTERED AS	{iso(1) member-body(2) us(840) 802dot3(10006) csmadtemgt(5) attribute(7) inRangeLengthErrors(136)};
<b>bInRangeLengthErrors</b>	<b>BEHAVIOUR</b>
DEFINED AS	See “BEHAVIOUR DEFINED AS” in 5.2.2.1.23.;
	NOTE—The approximate minimum time between counter rollovers is 80 h.;

<b>aOutOfRangeLengthField</b>	<b>ATTRIBUTE</b>
DERIVED FROM	aLMCounter;
BEHAVIOUR	bOutOfRangeLengthField;
REGISTERED AS	{iso(1) member-body(2) us(840) 802dot3(10006) csmadtemgt(5) attribute(7) outOutOfRangeLengthField(137)};
<b>bOutOfRangeLengthField</b>	<b>BEHAVIOUR</b>
DEFINED AS	See “BEHAVIOUR DEFINED AS” in 5.2.2.1.24.;
	NOTE—The approximate minimum time between counter rollovers is 80 h.;
<b>aFrameTooLongErrors</b>	<b>ATTRIBUTE</b>
DERIVED FROM	aLMCounter;
BEHAVIOUR	bFrameTooLongErrors;
REGISTERED AS	{iso(1) member-body(2) us(840) 802dot3(10006) csmadtemgt(5) attribute(7) frameTooLongErrors(138)};
<b>bFrameTooLongErrors</b>	<b>BEHAVIOUR</b>
DEFINED AS	See “BEHAVIOUR DEFINED AS” in 5.2.2.1.25.;
	NOTE—The approximate minimum time between counter rollovers is 61 days.;
<b>aMACEnableStatus</b>	<b>ATTRIBUTE</b>
WITH ATTRIBUTE SYNTAX	IEEE802Dot3-MgmtAttributeModule. TrueFalse;
BEHAVIOUR	bMACEnableStatus;
REGISTERED AS	{iso(1) member-body(2) us(840) 802dot3(10006) csmadtemgt(5) attribute(7) mACEnableStatus(139)};
<b>bMACEnableStatus</b>	<b>BEHAVIOUR</b>
DEFINED AS	See “BEHAVIOUR DEFINED AS” in 5.2.2.1.26.;
<b>aTransmitEnableStatus</b>	<b>ATTRIBUTE</b>
WITH ATTRIBUTE SYNTAX	IEEE802Dot3-MgmtAttributeModule. TrueFalse;
BEHAVIOUR	bTransmitEnableStatus;
REGISTERED AS	{iso(1) member-body(2) us(840) 802dot3(10006) csmadtemgt(5) attribute(7) transmitEnableStatus(140)};
<b>bTransmitEnableStatus</b>	<b>BEHAVIOUR</b>
DEFINED AS	See “BEHAVIOUR DEFINED AS” in 5.2.2.1.27.;
<b>aMulticastReceiveStatus</b>	<b>ATTRIBUTE</b>
WITH ATTRIBUTE SYNTAX	IEEE802Dot3-MgmtAttributeModule. TrueFalse;
BEHAVIOUR	bMulticastReceiveStatus;
REGISTERED AS	{iso(1) member-body(2) us(840) 802dot3(10006) csmadtemgt(5) attribute(7) multicastReceiveStatus(141)};
<b>bMulticastReceiveStatus</b>	<b>BEHAVIOUR</b>
DEFINED AS	See “BEHAVIOUR DEFINED AS” in 5.2.2.1.28.;
<b>aReadWriteMACAddress</b>	<b>ATTRIBUTE</b>
WITH ATTRIBUTE SYNTAX	IEEE802CommonDefinitions.MACAddress;
BEHAVIOUR	bReadWriteMACAddress;

REGISTERED AS {iso(1) member-body(2) us(840) 802dot3(10006) csmadtemgt(5) attribute(7) modifyMACAddress(142)};

**bReadWriteMACAddress**

**BEHAVIOUR**

DEFINED AS See “BEHAVIOUR DEFINED AS” in 5.2.2.1.29.;

NOTE—This maps to localMACAddress (of the mandatory macPackage) in ISO/IEC 10742: 1994.;

**aCollisionFrames**

**ATTRIBUTE**

WITH ATTRIBUTE SYNTAX

IEEE802Dot3-MgmtAttributeModule.

AttemptArray;

BEHAVIOUR

bCollisionFrames;

REGISTERED AS {iso(1) member-body(2) us(840) 802dot3(10006) csmadtemgt(5) attribute(7) collisionFrames(143)};

**bCollisionFrames**

**BEHAVIOUR**

DEFINED AS See “BEHAVIOUR DEFINED AS” in 5.2.2.1.30.;

NOTE—The approximate minimum time for any single counter rollover is 103 h.;

**H.1.1.3 DTE MAC sublayer actions**

**acInitializeMAC**

**ACTION**

BEHAVIOUR

bInitializeMAC;

MODE

CONFIRMED;

REGISTERED AS {iso(1) member-body(2) us(840) 802dot3(10006) csmadtemgt(5) action(9) initializeMAC(146)};

**bInitializeMAC**

**BEHAVIOUR**

DEFINED AS See “BEHAVIOUR DEFINED AS” in 5.2.2.2.1.;

**acAddGroupAddress**

**ACTION**

BEHAVIOUR

bAddGroupAddress;

MODE

CONFIRMED;

WITH INFORMATION SYNTAX

IEEE802CommonDefinitions.MACAddress;

REGISTERED AS {iso(1) member-body(2) us(840) 802dot3(10006) csmadtemgt(5) action(9) addGroupAddress(147)};

**bAddGroupAddress**

**BEHAVIOUR**

DEFINED AS See “BEHAVIOUR DEFINED AS” in 5.2.2.2.2.;

**acDeleteGroupAddress**

**ACTION**

BEHAVIOUR

bDeleteGroupAddress;

MODE

CONFIRMED;

WITH INFORMATION SYNTAX

IEEE802CommonDefinitions.MACAddress;

REGISTERED AS {iso(1) member-body(2) us(840) 802dot3(10006) csmadtemgt(5) action(9) deleteGroupAddress(148)};

**bDeleteGroupAddress**

**BEHAVIOUR**

DEFINED AS See “BEHAVIOUR DEFINED AS” in 5.2.2.2.3.;

**acExecuteSelfTest**

**ACTION**

BEHAVIOUR

bExecuteSelfTestMAC;

MODE CONFIRMED;  
REGISTERED AS {iso(1) member-body(2) us(840) 802dot3(10006) csmadtemgt(5)  
action(9) executeSelfTestMAC(149)};

**bExecuteSelfTest** BEHAVIOUR  
DEFINED AS See “BEHAVIOUR DEFINED AS” in 5.2.2.2.4.;

## H.1.2 ResourceTypeID managed object class

### H.1.2.1 ResourceTypeID, formal definition

-- Implementation of this managed object in accordance with the definition contained in  
-- IEEE Std 802.1F-1993 is a conformance requirement of this standard.  
-- NOTE—A single instance of the Resource Type ID managed object exists within the  
-- DTE–MAC managed object class. The managed object itself is contained in IEEE Std 802.1F-1993;  
-- therefore, only the name binding appears in this standard;

**nbResourceTypeID** NAME BINDING  
SUBORDINATE OBJECT CLASS “IEEE802.1F”:oResourceTypeID;  
NAMED BY SUPERIOR OBJECT CLASS  
oMAC-Entity;  
WITH ATTRIBUTE “IEEE802.1F”:aResourceTypeIDName;  
REGISTERED AS {iso(1) member-body(2) us(840) 802dot3(10006) csmadtemgt(5)  
nameBinding(6) resourceTypeID(111)};

## H.1.3 DTE physical layer managed object class

### H.1.3.1 DTE physical layer formal definition

**oPHY-entity** MANAGED OBJECT CLASS  
DERIVED FROM “CCITT Rec. X.721 (1992) | ISO/IEC 10165-2 :  
1992”:top;  
CHARACTERIZED BY  
**pMandatory** PACKAGE  
*--There are no mandatory Attributes, Actions, or Notifications;*  
*--therefore, management of this object is not required if only*  
*--the mandatory package is implemented.*  
;  
;  
CONDITIONAL PACKAGES  
**pRecommended** PACKAGE  
ATTRIBUTES aPHYID GET,  
aSQETestErrors GET;  
REGISTERED AS {iso(1) member-body(2) us(840) 802dot3(10006)  
csmadtemgt(5) package(4)  
phyRecommendedPkg(108)};  
PRESENT IF The Recommended Package is implemented. ;  
REGISTERED AS {iso(1) member-body(2) us(840) 802dot3(10006) csmadtemgt(5)  
managedObjectClass(3) phyObjectClass(102)};

**nbPHYName** NAME BINDING  
SUBORDINATE OBJECT CLASS oPHY-entity;  
NAMED BY SUPERIOR OBJECT CLASS

oMAC-entity;;  
aPHYID;  
WITH ATTRIBUTE  
REGISTERED AS {iso(1) member-body(2) us(840) 802dot3(10006) csmadtemgt(5)  
nameBinding(6) phyName(112)};

**nbPHYMonitor** **NAME BINDING**  
SUBORDINATE OBJECT CLASS “IEEE802.1F”:ewmaMetricMonitor;  
NAMED BY SUPERIOR OBJECT CLASS  
“ISO/IEC 10165-2”:system;  
WITH ATTRIBUTE  
aScannerId;  
**CREATE** **WITH-AUTOMATIC-INSTANCE-NAMING;**  
**DELETE** **ONLY-IF-NO-CONTAINED-OBJECTS;**  
REGISTERED AS {iso(1) member-body(2) us(840) 802dot3(10006) csmadtemgt(5)  
nameBinding(6) phyMonitor(113)};

### H.1.3.2 DTE physical sublayer attributes

**aPHYID** **ATTRIBUTE**  
WITH ATTRIBUTE SYNTAX IEEE802Dot3-MgmtAttributeModule.  
OneOfName;  
MATCHES FOR  
BEHAVIOUR EQUALITY;  
bPHYID;  
REGISTERED AS {iso(1) member-body(2) us(840) 802dot3(10006) csmadtemgt(5)  
attribute(7) phyID(144)};

**bPHYID** **BEHAVIOUR**  
DEFINED AS See “BEHAVIOUR DEFINED AS” in 5.2.3.1.1.;

**aSQETestErrors** **ATTRIBUTE**  
DERIVED FROM  
BEHAVIOUR aLMCounter;  
bSQETestErrors;  
REGISTERED AS {iso(1) member-body(2) us(840) 802dot3(10006) csmadtemgt(5)  
attribute(7) sqeTestErrors(145)};

**bSQETestErrors** **BEHAVIOUR**  
DEFINED AS See “BEHAVIOUR DEFINED AS” in 5.2.3.1.2.;

NOTE—The approximate minimum time between counter rollovers is 80 h.;

## H.2 GDMO specification for Repeater Management Object Class

NOTE—The arcs (that is, object identifier values) defined in Annex 30A deprecate the arcs previously defined in H.1 (Layer Management), H.2 (Repeater Management), and H.3 (MAU Management). See IEEE Std 802.1F-1993, Annex C4.

This subclause formally defines the Repeater Management Objects using the templates specified in ISO/IEC 10165-4: 1992.

The protocol encodings for CMIP, and therefore ISO/IEC 15802-2: 1995 can be derived from H.2.1 to H.2.5 directly. The template defined in ISO/IEC 10165-4 specifies precisely the syntax used in this document to define the operation, objects and attributes. The application of a GDMO template compiler against H.2.1 to H.2.5 will produce the proper protocol encodings.



Each attribute definition in this clause references directly by means of the WITH ATTRIBUTE SYNTAX construct or indirectly by means of the DERIVED FROM construct an ASN.1 type or subtype that defines the attribute's type and range. Those ASN.1 types and subtypes defined exclusively for CSMA/CD Management are appear in a single ASN.1 module in Annex H.

## H.2.1 Repeater managed object class

### H.2.1.1 Repeater, formal definition

```

oRepeater                                MANAGED OBJECT CLASS
  DERIVED FROM                               "CCITT Rec. X.721 (1992) | ISO/IEC 10165-2
                                              1992":top;

  CHARACTERIZED BY
    pRepeaterBasicControl                PACKAGE
      ATTRIBUTES                            aRepeaterID                                GET,
                                              aRepeaterGroupCapacity                    GET,
                                              aGroupMap                                 GET,
                                              aRepeaterHealthState                     GET,
                                              aRepeaterHealthText                       GET,
                                              aRepeaterHealthData                       GET;
      ACTIONS                               acResetRepeater,
                                              acExecuteNonDisruptiveSelfTest;
      NOTIFICATIONS                          nRepeaterHealth,
                                              nRepeaterReset,
                                              nGroupMapChange;
  ;
;
  CONDITIONAL PACKAGES
    pRepeaterPerfMonitor                PACKAGE
      ATTRIBUTES                            aTransmitCollisions                        GET;
      REGISTERED AS                          {iso(1) member-body(2) us(840) 802dot3(10006)
                                              repeaterMgt(19) package(4)
                                              repeaterPerfMonitorPkg(4)};
      PRESENT IF                             The Performance Monitor Capability is implemented.;
  REGISTERED AS                              {iso(1) member-body(2) us(840) 802dot3(10006) repeaterMgt(19)
                                              managedObjectClass(3) repeaterObjectClass(1)};

nbRepeaterName                          NAME BINDING
  SUBORDINATE OBJECT CLASS                  repeater;
  NAMED BY SUPERIOR OBJECT CLASS
                                              "ISO/IEC 10165-2":system AND SUBCLASSES;
  WITH ATTRIBUTE                            aRepeaterID;
  REGISTERED AS                              {iso(1) member-body(2) us(840) 802dot3(10006) repeaterMgt(19)
                                              nameBinding(6) repeaterName(7)};

nbRepeaterMonitor                       NAME BINDING
  SUBORDINATE OBJECT CLASS                  "IEEE802.1F":oEWMAMetricMonitor;
  NAMED BY SUPERIOR OBJECT CLASS
                                              "ISO/IEC 10165-2":system AND SUBCLASSES;
  WITH ATTRIBUTE                            aScannerId;
  CREATE                                    WITH-AUTOMATIC-INSTANCE-NAMING;
  DELETE                                    ONLY-IF-NO-CONTAINED-OBJECTS;
  REGISTERED AS                              {iso(1) member-body(2) us(840) 802dot3(10006) repeaterMgt(19)

```

nameBinding(6) repeaterMonitor(8));

### H.2.1.2 Repeater attributes

<b>aRepeaterID</b>	<b>ATTRIBUTE</b>
WITH ATTRIBUTE SYNTAX	IEEE802Dot3-MgmtAttributeModule. OneOfName;
MATCHES FOR	EQUALITY;
BEHAVIOUR	bRepeaterID;
REGISTERED AS	{iso(1) member-body(2) us(840) 802dot3(10006) repeaterMgt(19) attribute(7) repeaterID(13)};
<b>bRepeaterID</b>	<b>BEHAVIOUR</b>
DEFINED AS	See "BEHAVIOUR DEFINED AS" in 19.2.3.2.1.;
<b>aRepeaterGroupCapacity</b>	<b>ATTRIBUTE</b>
WITH ATTRIBUTE SYNTAX	IEEE802Dot3-MgmtAttributeModule. OneOfName;
MATCHES FOR	EQUALITY, ORDERING;
BEHAVIOUR	bRepeaterGroupCapacity;
REGISTERED AS	{iso(1) member-body(2) us(840) 802dot3(10006) repeaterMgt(19) attribute(7) repeaterGroupCapacity(14)};
<b>bRepeaterGroupCapacity</b>	<b>BEHAVIOUR</b>
DEFINED AS	See "BEHAVIOUR DEFINED AS" in 19.2.3.2.2.;
<b>aGroupMap</b>	<b>ATTRIBUTE</b>
WITH ATTRIBUTE SYNTAX	IEEE802Dot3-MgmtAttributeModule. BitString;
MATCHES FOR	EQUALITY;
BEHAVIOUR	bGroupMap;
REGISTERED AS	{iso(1) member-body(2) us(840) 802dot3(10006) repeaterMgt(19) attribute(7) groupMap(15)};
<b>bGroupMap</b>	<b>BEHAVIOUR</b>
DEFINED AS	See "BEHAVIOUR DEFINED AS" in 19.2.3.2.3.;
<b>aRepeaterHealthState</b>	<b>ATTRIBUTE</b>
WITH ATTRIBUTE SYNTAX	IEEE802Dot3-MgmtAttributeModule. RepeaterHealthState;
MATCHES FOR	EQUALITY;
BEHAVIOUR	bRepeaterHealthState;
REGISTERED AS	{iso(1) member-body(2) us(840) 802dot3(10006) repeaterMgt(19) attribute(7) repeaterHealthState(16)};
<b>bRepeaterHealthState</b>	<b>BEHAVIOUR</b>
DEFINED AS	See "BEHAVIOUR DEFINED AS" in 19.2.3.2.4.;
<b>aRepeaterHealthText</b>	<b>ATTRIBUTE</b>
WITH ATTRIBUTE SYNTAX	IEEE802Dot3-MgmtAttributeModule. RepeaterHealthText;
MATCHES FOR	EQUALITY;
BEHAVIOUR	bRepeaterHealthText;
REGISTERED AS	{iso(1) member-body(2) us(840) 802dot3(10006) repeaterMgt(19) attribute(7) repeaterHealthText(17)};

**bRepeaterHealthText**  
DEFINED AS

**BEHAVIOUR**  
See “BEHAVIOUR DEFINED AS” in 19.2.3.2.5.;

**aRepeaterHealthData**  
WITH ATTRIBUTE SYNTAX

**ATTRIBUTE**  
IEEE802Dot3-MgmtAttributeModule.  
RepeaterHealthData;  
EQUALITY;  
bRepeaterHealthData;

MATCHES FOR  
BEHAVIOUR  
REGISTERED AS

{iso(1) member-body(2) us(840) 802dot3(10006) repeaterMgt(19)  
attribute(7) repeaterHealthData(18)};

**bRepeaterHealthData**  
DEFINED AS

**BEHAVIOUR**  
See “BEHAVIOUR DEFINED AS” in 19.2.3.2.6.;

**aTransmitCollisions**  
DERIVED FROM  
BEHAVIOUR  
REGISTERED AS

**ATTRIBUTE**  
aRMCounter;  
bTransmitCollisions;  
{iso(1) member-body(2) us(840) 802dot3(10006) repeaterMgt(19)  
attribute(7) transmitCollisions (19)};

**bTransmitCollisions**  
DEFINED AS

**BEHAVIOUR**  
See “BEHAVIOUR DEFINED AS” in 19.2.3.2.7.;

NOTE—The approximate minimum time for counter rollover is 16 h.;

### H.2.1.3 Repeater actions

**acResetRepeater**  
BEHAVIOUR  
MODE  
REGISTERED AS

**ACTION**  
bResetRepeater;  
CONFIRMED;  
{iso(1) member-body(2) us(840) 802dot3(10006) repeaterMgt(19)  
action(9) resetRepeater(40)};

**bResetRepeater**  
DEFINED AS

**BEHAVIOUR**  
See “BEHAVIOUR DEFINED AS” in 19.2.3.3.1.;

**acExecuteNonDisruptiveSelfTest**  
BEHAVIOUR  
REGISTERED AS

**ACTION**  
bExecuteNonDisruptiveSelfTest;  
{iso(1) member-body(2) us(840) 802dot3(10006) repeaterMgt(19)  
action(9) executeNonDisruptiveSelfTestAction(41)};

**bExecuteNonDisruptiveSelfTest**  
DEFINED AS

**BEHAVIOUR**  
See “BEHAVIOUR DEFINED AS” in 19.2.3.3.2.;

### H.2.1.4 Repeater notifications

**nRepeaterHealth** NOTIFICATION  
BEHAVIOUR  
WITH INFORMATION SYNTAX

bRepeaterHealth;  
IEEE802Dot3-MgmtAttributeModule.  
RepeaterHealthInfo  
fnRepeaterHealthState aRepeaterHealthState,  
fnRepeaterHealthText aRepeaterHealthText,  
fnRepeaterHealthData aRepeaterHealthData

AND ATTRIBUTE IDS

;  
REGISTERED AS {iso(1) member-body(2) us(840) 802dot3(10006) repeaterMgt(19)

notification(10) repeaterHealth(43));

**bRepeaterHealth**  
DEFINED AS

**BEHAVIOUR**  
See “BEHAVIOUR DEFINED AS” in 19.2.3.4.1.;

**nRepeaterReset**  
BEHAVIOUR  
WITH INFORMATION SYNTAX  
  
AND ATTRIBUTE IDS

**NOTIFICATION**  
bRepeaterReset;  
IEEE802Dot3-MgmtAttributeModule.  
RepeaterHealthInfo  
fnRepeaterHealthState aRepeaterHealthState,  
fnRepeaterHealthText aRepeaterHealthText,  
fnRepeaterHealthData aRepeaterHealthData

REGISTERED AS {iso(1) member-body(2) us(840) 802dot3(10006) repeaterMgt(19)  
notification(10) repeaterReset(44)};

**bRepeaterReset**  
DEFINED AS

**BEHAVIOUR**  
See “BEHAVIOUR DEFINED AS” in 19.2.3.4.2.;

**nGroupMapChange**  
BEHAVIOUR  
WITH INFORMATION SYNTAX  
REGISTERED AS

**NOTIFICATION**  
bGroupMapChange;  
IEEE802Dot3-MgmtAttributeModule.BitString;  
{iso(1) member-body(2) us(840) 802dot3(10006) repeaterMgt(19)  
notification(10) groupMapChange(45)};

**bGroupMapChange**  
DEFINED AS

**BEHAVIOUR**  
See “BEHAVIOUR DEFINED AS” in 19.2.3.4.3.;

## H.2.2 ResourceTypeId managed object class

### H.2.2.1 ResourceTypeId formal definition

- Implementation of this managed object in accordance with the definition contained in
- IEEE Std 802.1F-1993 is a conformance requirement of this standard.
- NOTE—A single instance of the Resource Type ID managed object exists within the
- Repeater managed object class. The managed object itself is contained in
- IEEE Std. 802.1F-1993; therefore, only the name binding appears in this standard.

**nbResourceTypeId**

**NAME BINDING**

SUBORDINATE OBJECT CLASS  
NAMED BY SUPERIOR OBJECT CLASS

“IEEE802.1F”:oResourceTypeID;

WITH ATTRIBUTE

oRepeater AND SUBCLASSES;  
“IEEE802.1F”:aResourceTypeIDName;

REGISTERED AS {iso(1) member-body(2) us(840) 802dot3(10006) repeaterMgt(19)  
nameBinding(6) resourceTypeID(9)};

## H.2.3 Group managed object class

### H.2.3.1 Group formal definition

**oGroup** **MANAGED OBJECT CLASS**  
 DERIVED FROM “CCITT Rec. X.721 (1992) | ISO/IEC 10165-2 1992”:top;  
 CHARACTERIZED BY  
     **pGroupBasicControl** **PACKAGE**  
     ATTRIBUTES aGroupID GET,  
                   aGroupPortCapacity GET,  
                   aPortMap GET;  
     NOTIFICATIONS nPortMapChange;  
 ;  
 ;  
 REGISTERED AS {iso(1) member-body(2) us(840) 802dot3(10006) repeaterMgt(19)  
 managedObjectClass(3) groupObjectClass(2)};

**nbGroupName** **NAME BINDING**  
 SUBORDINATE OBJECT CLASS oGroup;  
 NAMED BY SUPERIOR OBJECT CLASS  
     oRepeater AND SUBCLASSES;  
 WITH ATTRIBUTE aGroupID;  
 REGISTERED AS {iso(1) member-body(2) us(840) 802dot3(10006) repeaterMgt(19)  
 nameBinding(6) groupName(10)};

### H.2.3.2 Group attributes

**aGroupID** **ATTRIBUTE**  
 WITH ATTRIBUTE SYNTAX IEEE802Dot3-MgmtAttributeModule.  
 OneOfName;  
 MATCHES FOR EQUALITY;  
 BEHAVIOUR bGroupID;  
 REGISTERED AS {iso(1) member-body(2) us(840) 802dot3(10006) repeaterMgt(19)  
 attribute(7) groupID(20)};

**bGroupID** **BEHAVIOUR**  
 DEFINED AS See “BEHAVIOUR DEFINED AS” in 19.2.5.1.1.;

**aGroupPortCapacity** **ATTRIBUTE**  
 WITH ATTRIBUTE SYNTAX IEEE802Dot3-MgmtAttributeModule.  
 OneOfName;  
 MATCHES FOR EQUALITY, ORDERING;  
 BEHAVIOUR bGroupPortCapacity;  
 REGISTERED AS {iso(1) member-body(2) us(840) 802dot3(10006) repeaterMgt(19)  
 attribute(7) groupPortCapacity(21)};

**bGroupPortCapacity** **BEHAVIOUR**  
 DEFINED AS See “BEHAVIOUR DEFINED AS” in 19.2.5.1.2.;

**aPortMap** **ATTRIBUTE**  
 WITH ATTRIBUTE SYNTAX IEEE802Dot3-MgmtAttributeModule.  
 BitString;  
 MATCHES FOR EQUALITY;  
 BEHAVIOUR bPortMap;

REGISTERED AS {iso(1) member-body(2) us(840) 802dot3(10006) repeaterMgt(19) attribute(7) portMap(22)};

**bPortMap**

DEFINED AS

**BEHAVIOUR**

See “BEHAVIOUR DEFINED AS” in 19.2.5.1.3.;

**H.2.3.3 Group notifications**

**nPortMapChange**

BEHAVIOUR

WITH INFORMATION SYNTAX

REGISTERED AS

{iso(1) member-body(2) us(840) 802dot3(10006) repeaterMgt(19) notification(10) portMapChange(46)};

**NOTIFICATION**

bPortMapChange;

IEEE802Dot3-MgmtAttributeModule.BitString;

**bPortMapChange**

DEFINED AS

**BEHAVIOUR**

See “BEHAVIOUR DEFINED AS” in 19.2.5.2.1.;

**H.2.4 Port managed object class**

**H.2.4.1 Port formal definition**

**oPort**

DERIVED FROM

**MANAGED OBJECT CLASS**

"CCITT Rec. X.721 (1992) | ISO/IEC 10165-2 1992":top;

CHARACTERIZED BY

**pPortBasicControl**

ATTRIBUTES

**PACKAGE**

aPortID GET,  
aPortAdminState GET,  
aAutoPartitionState GET;  
acPortAdminControl;

ACTIONS

;

;

CONDITIONAL PACKAGES

**pPortPerfMonitor**

ATTRIBUTES

**PACKAGE**

aReadableFrames GET,  
aReadableOctets GET,  
aFrameCheckSequenceErrors GET,  
aAlignmentErrors GET,  
aFramesTooLong GET,  
aShortEvents GET,  
aRunts GET,  
aCollisions GET,  
aLateEvents GET,  
aVeryLongEvents GET,  
aDataRateMismatches GET,  
aAutoPartitions GET;

REGISTERED AS

{iso(1) member-body(2) us(840) 802dot3(10006) repeaterMgt(19) package(4) portPerfMonitorPkg(5)};

PRESENT IF

The Performance Monitor Capability is implemented.;

<b>pPortAddrTracking</b>	<b>PACKAGE</b>
ATTRIBUTES	aLastSourceAddress GET; aSourceAddressChanges GET;
REGISTERED AS	{iso(1) member-body(2) us(840) 802dot3(10006) repeaterMgt(19) package(4) portAddrTrackPkg(6)};
PRESENT IF	The Address Tracking and Performance Monitor capabilities are implemented.;
REGISTERED AS	{iso(1) member-body(2) us(840) 802dot3(10006) repeaterMgt(19) managedObjectClass(3) portObjectClass(3)};
<b>nbPortName</b>	<b>NAME BINDING</b>
SUBORDINATE OBJECT CLASS	oPort;
NAMED BY SUPERIOR OBJECT CLASS	oGroup AND SUBCLASSES;
WITH ATTRIBUTE	aPortID;
REGISTERED AS	{iso(1) member-body(2) us(840) 802dot3(10006) repeaterMgt(19) nameBinding(6) portName(11)};

#### H.2.4.2 Port attributes

<b>aPortID</b>	<b>ATTRIBUTE</b>
WITH ATTRIBUTE SYNTAX	IEEE802Dot3-MgmtAttributeModule. OneOfName;
BEHAVIOUR	bPortID;
REGISTERED AS	{iso(1) member-body(2) us(840) 802dot3(10006) repeaterMgt(19) attribute(7) portID(23)};
<b>bPortID</b>	<b>BEHAVIOUR</b>
DEFINED AS	See “BEHAVIOUR DEFINED AS” in 19.2.6.1.1.;
<b>aPortAdminState</b>	<b>ATTRIBUTE</b>
WITH ATTRIBUTE SYNTAX	IEEE802Dot3-MgmtAttributeModule. PortAdminState;
MATCHES FOR BEHAVIOUR	EQUALITY; bPortAdminState;
REGISTERED AS	{iso(1) member-body(2) us(840) 802dot3(10006) repeaterMgt(19) attribute(7) portAdminState(24)};
<b>bPortAdminState</b>	<b>BEHAVIOUR</b>
DEFINED AS	See “BEHAVIOUR DEFINED AS” in 19.2.6.1.2.;
<b>aAutoPartitionState</b>	<b>ATTRIBUTE</b>
WITH ATTRIBUTE SYNTAX	IEEE802Dot3-MgmtAttributeModule. AutoPartitionState;
MATCHES FOR BEHAVIOUR	EQUALITY; bAutoPartition;
REGISTERED AS	{iso(1) member-body(2) us(840) 802dot3(10006) repeaterMgt(19) attribute(7) autoPartitionState(25)};
<b>bAutoPartition</b>	<b>BEHAVIOUR</b>
DEFINED AS	See “BEHAVIOUR DEFINED AS” in 19.2.6.1.3.;
<b>aReadableFrames</b>	<b>ATTRIBUTE</b>
DERIVED FROM BEHAVIOUR	aRMCounter; bReadableFrames;

REGISTERED AS	{iso(1) member-body(2) us(840) 802dot3(10006) repeaterMgt(19) attribute(7) readableFrames(26)};
<b>bReadableFrames</b> DEFINED AS	<b>BEHAVIOUR</b> See “BEHAVIOUR DEFINED AS” in 19.2.6.1.4. NOTE—The approximate minimum time between counter rollovers is 80 h.;
<b>aReadableOctets</b> DERIVED FROM BEHAVIOUR REGISTERED AS	<b>ATTRIBUTE</b> aRMCounter; bReadableOctets; {iso(1) member-body(2) us(840) 802dot3(10006) repeaterMgt(19) attribute(7) readableOctets(27)};
<b>bReadableOctets</b> DEFINED AS	<b>BEHAVIOUR</b> See “BEHAVIOUR DEFINED AS” in 19.2.6.1.5. NOTE—The approximate minimum time between counter rollovers is 58 min.;
<b>aFrameCheckSequenceErrors</b> DERIVED FROM BEHAVIOUR REGISTERED AS	<b>ATTRIBUTE</b> aRMCounter; bFCSErrors; {iso(1) member-body(2) us(840) 802dot3(10006) repeaterMgt(19) attribute(7) frameCheckSequenceErrors(28)};
<b>bFCSErrors</b> DEFINED AS	<b>BEHAVIOUR</b> See “BEHAVIOUR DEFINED AS” in 19.2.6.1.6. NOTE—The approximate minimum time between counter rollovers is 80 h.;
<b>aAlignmentErrors</b> DERIVED FROM BEHAVIOUR REGISTERED AS	<b>ATTRIBUTE</b> aRMCounter; bAlignmentErrors; {iso(1) member-body(2) us(840) 802dot3(10006) repeaterMgt(19) attribute(7) alignmentErrors(29)};
<b>bAlignmentErrors</b> DEFINED AS	<b>BEHAVIOUR</b> See “BEHAVIOUR DEFINED AS” in 19.2.6.1.7. NOTE—The approximate minimum time between counter rollovers is 80 h.;
<b>aFramesTooLong</b> DERIVED FROM BEHAVIOUR REGISTERED AS	<b>ATTRIBUTE</b> aRMCounter; bFramesTooLong; {iso(1) member-body(2) us(840) 802dot3(10006) repeaterMgt(19) attribute(7) framesTooLong(30)};
<b>bFramesTooLong</b> DEFINED AS	<b>BEHAVIOUR</b> See “BEHAVIOUR DEFINED AS” in 19.2.6.1.8. NOTE—The approximate minimum time between counter rollovers is 61 days.;
<b>aShortEvents</b> DERIVED FROM BEHAVIOUR REGISTERED AS	<b>ATTRIBUTE</b> aRMCounter; bShortEvents; {iso(1) member-body(2) us(840) 802dot3(10006) repeaterMgt(19) attribute(7) shortEvents(31)};



<b>bShortEvents</b> DEFINED AS	<b>BEHAVIOUR</b> See “BEHAVIOUR DEFINED AS” in 19.2.6.1.9.  NOTE—The approximate minimum time between counter rollovers is 16 h;
<b>aRunts</b> DERIVED FROM BEHAVIOUR REGISTERED AS	<b>ATTRIBUTE</b> aRMCounter; bRunts;  {iso(1) member-body(2) us(840) 802dot3(10006) repeaterMgt(19) attribute(7) runts(32)};
<b>bRunts</b> DEFINED AS	<b>BEHAVIOUR</b> See “BEHAVIOUR DEFINED AS” in 19.2.6.1.10.  NOTE—The approximate minimum time for counter rollover is 16 h.;
<b>aCollisions</b> DERIVED FROM BEHAVIOUR REGISTERED AS	<b>ATTRIBUTE</b> aRMCounter; bCollisions;  {iso(1) member-body(2) us(840) 802dot3(10006) repeaterMgt(19) attribute(7) collisions(33)};
<b>bCollisions</b> DEFINED AS	<b>BEHAVIOUR</b> See “BEHAVIOUR DEFINED AS” in 19.2.6.1.11.  NOTE—The approximate minimum time for counter rollover is 16 h.;
<b>aLateEvents</b> DERIVED FROM BEHAVIOUR REGISTERED AS	<b>ATTRIBUTE</b> aRMCounter; bLateEvents;  {iso(1) member-body(2) us(840) 802dot3(10006) repeaterMgt(19) attribute(7) lateEvents(34)};
<b>bLateEvents</b> DEFINED AS	<b>BEHAVIOUR</b> See “BEHAVIOUR DEFINED AS” in 19.2.6.1.12.  NOTE—The approximate minimum time between counter rollovers is 81 h.;
<b>aVeryLongEvents</b> DERIVED FROM BEHAVIOUR REGISTERED AS	<b>ATTRIBUTE</b> aRMCounter; bVeryLongEvents;  {iso(1) member-body(2) us(840) 802dot3(10006) repeaterMgt(19) attribute(7) veryLongEvents(35)};
<b>bVeryLongEvents</b> DEFINED AS	<b>BEHAVIOUR</b> See “BEHAVIOUR DEFINED AS” in 19.2.6.1.13. ;  NOTE—The approximate minimum time between counter rollovers is 198 days.;
<b>aDataRateMismatches</b> DERIVED FROM BEHAVIOUR REGISTERED AS	<b>ATTRIBUTE</b> aRMCounter; bDataRateMismatches;  {iso(1) member-body(2) us(840) 802dot3(10006) repeaterMgt(19) attribute(7) dataRateMismatches(36)};
<b>bDataRateMismatches</b> DEFINED AS	<b>BEHAVIOUR</b> See “BEHAVIOUR DEFINED AS” in 19.2.6.1.14.;

<b>aAutoPartitions</b>	<b>ATTRIBUTE</b>
DERIVED FROM	aRMCounter;
BEHAVIOUR	bAutoPartitions;
REGISTERED AS	{iso(1) member-body(2) us(840) 802dot3(10006) repeaterMgt(19) attribute(7) autoPartitions(37)};

<b>bAutoPartitions</b>	<b>BEHAVIOUR</b>
DEFINED AS	See “BEHAVIOUR DEFINED AS” in 19.2.6.1.15.;

<b>aLastSourceAddress</b>	<b>ATTRIBUTE</b>
WITH ATTRIBUTE SYNTAX	IEEE802CommonDefinitions.MACAddress;
MATCHES FOR	EQUALITY;
BEHAVIOUR	bLastSourceAddress;
REGISTERED AS	{iso(1) member-body(2) us(840) 802dot3(10006) repeaterMgt(19) attribute(7) lastSourceAddress(38)};

<b>bLastSourceAddress</b>	<b>BEHAVIOUR</b>
DEFINED AS	See “BEHAVIOUR DEFINED AS” in 19.2.6.1.16.;

<b>aSourceAddressChanges</b>	<b>ATTRIBUTE</b>
DERIVED FROM	aRMCounter;
BEHAVIOUR	bSourceAddressChanges;
REGISTERED AS	{iso(1) member-body(2) us(840) 802dot3(10006) repeaterMgt(19) attribute(7) sourceAddressChanges(39)};

<b>bSourceAddressChanges</b>	<b>BEHAVIOUR</b>
DEFINED AS	See “BEHAVIOUR DEFINED AS” in 19.2.6.1.17.

NOTE—The approximate minimum time for counter rollover is 81 h.;

#### H.2.4.3 Port actions

<b>acPortAdminControl</b>	<b>ACTION</b>
BEHAVIOUR	bPortAdminControl;
WITH INFORMATION SYNTAX	IEEE802Dot3-MgmtAttributeModule.
	PortAdminState;
REGISTERED AS	{iso(1) member-body(2) us(840) 802dot3(10006) repeaterMgt(19) action(9) portAdminControl(42)};

<b>bPortAdminControl</b>	<b>BEHAVIOUR</b>
DEFINED AS	See “BEHAVIOUR DEFINED AS” in 19.2.6.2.1.;

#### H.2.5 Common Attributes Template

<b>aRMCounter</b>	<b>ATTRIBUTE</b>
DERIVED FROM	"ISO/IEC 10165-2":GenericSettableCounter
BEHAVIOUR	bRMCounter
REGISTERED AS	{iso(1) member-body(2) us(840) 802dot3(10006) repeaterMgt(19) attribute(7) rmCounter(12)};

<b>bRMCounter</b>	<b>BEHAVIOUR</b>
DEFINED AS	The internal event that is counted is specified by each calling attribute. The maximum value is 4 294 967 295 (i.e., wraps at 32 bits). The estimated minimum wrap time is called out in a note included in the

behaviour of each calling attribute.

The counter that this is derived from initializes to zero. Initialization to zero is not a requirement of this standard, this standard only supports a GET operation of this counter.;

### H.3 GDMO specification for MAU Management Objects

NOTE—The arcs (that is, object identifier values) defined in Annex 30A deprecate the arcs previously defined in H.1 (Layer Management), H.2 (Repeater Management), and H.3 (MAU Management). See IEEE Std 802.1F-1993, Annex C4.

This clause formally defines the MAU Management Objects using the templates specified in ISO/IEC 10165-4: 1992.

Each attribute definition in this clause references directly by means of the WITH ATTRIBUTE SYNTAX construct or indirectly by means of the DERIVED FROM construct an ASN.1 type or subtype that defines the attribute's type and range. Those ASN.1 types and subtypes defined exclusively for CSMA/CD Management are included in H.4.

#### H.3.1 MAU Managed Object Class

##### H.3.1.1 MAU formal definition

```

oMAU                                MANAGED OBJECT CLASS
  DERIVED FROM                          "CCITT Rec. X.721 (1992) | ISO/IEC 10165-2 : 1992":top;
  CHARACTERIZED BY
    pMAUBasic                           PACKAGE
      ATTRIBUTES                          aMAUID                                GET;
                                           aMAUType                             GET;
                                           aMediaAvailable                       GET;
                                           aJabber                               GET;
                                           aMAUAdminControl                     GET;
      NOTIFICATIONS                       nJabber;
    ;
  ;
  CONDITIONAL PACKAGES
    pMAUControl                           PACKAGE
      ACTIONS                             acResetMAU,
                                           acMAUAdminState;
      REGISTERED AS                       {iso(1) std(0) iso8802(8802) csma(3) mauMgt(20) package(4) mau-
                                           ControlPkg(202)};
      PRESENT IF                          The pMAUControl package is implemented.;

    pMediaLossTracking                   PACKAGE
      ATTRIBUTES                          aLoseMediaCounter                   GET;
      REGISTERED AS                       {iso(1) std(0) iso8802(8802) csma(3) mauMgt(20) package(4) media-
                                           LossTrackingPkg(203)};
      PRESENT IF                          MAU TypeValue = AUI or if the pMediaLossTracking package is
                                           implemented.;

    pBroadbandDTEMAU                     PACKAGE
      ATTRIBUTES                          aBbMAUXmitRcvSplitType             GET;
                                           aBroadbandFrequencies               GET;
      REGISTERED AS                       {iso(1) std(0) iso8802(8802) csma(3) mauMgt(20) package(4) broad-
                                           bandMAUPkg(204)};

```

PRESENT IF The MAU is of type 10BROAD36.;

REGISTERED AS {iso(1) std(0) iso8802(8802) csma(3) mauMgt(20)  
managedObjectClass(3) mauObjectClass(201)};

**nbRepeaterMAUName** NAME BINDING  
SUBORDINATE OBJECT CLASS oMAU;  
NAMED BY SUPERIOR OBJECT CLASS (of oRepeaterPort)  
oPort AND SUBCLASSES;  
--{1.2.840.10006.19.3.3}  
WITH ATTRIBUTE aMAUID;  
REGISTERED AS {iso(1) std(0) iso8802(8802) csma(3) mauMgt(20) nameBinding(6)  
repeaterName(205)};

**nbDTEMAUName** NAME BINDING  
SUBORDINATE OBJECT CLASS oMAU;  
NAMED BY SUPERIOR OBJECT CLASS (of oDTEPort)  
oDTECSMACDInterface AND SUBCLASSES  
(1.2.840.10006.5.3.X);  
WITH ATTRIBUTE aMAUID;  
REGISTERED AS {iso(1) std(0) iso8802(8802) csma(3) mauMgt(20) nameBinding(6)  
dteName(206)};

### H.3.1.2 MAU attributes

**aMAUID** ATTRIBUTE  
WITH ATTRIBUTE SYNTAX IEEE802Dot3-MgmtAttributeModule.  
OneOfName;  
MATCHES FOR EQUALITY;  
BEHAVIOUR bMAUID;  
REGISTERED AS {iso(1) std(0) iso8802(8802) csma(3) mauMgt(20) attribute(7)  
mauID(207)};

**bMAUID** BEHAVIOUR  
DEFINED AS See “BEHAVIOUR DEFINED AS” in 20.2.2.1.1.;

**aMAUType** ATTRIBUTE  
WITH ATTRIBUTE SYNTAX IEEE802Dot3-MgmtAttributeModule.  
TypeValue;  
MATCHES FOR EQUALITY, ORDERING;  
BEHAVIOUR bMAUType;  
REGISTERED AS {iso(1) std(0) iso8802(8802) csma(3) mauMgt(20) attribute(7)  
mauType(208)};

**bMAUType** BEHAVIOUR  
DEFINED AS See “BEHAVIOUR DEFINED AS” in 20.2.2.1.2.;

**aMediaAvailable** ATTRIBUTE  
WITH ATTRIBUTE SYNTAX IEEE802Dot3-MgmtAttributeModule.  
MediaAvailState;  
MATCHES FOR EQUALITY, ORDERING;  
BEHAVIOUR bMediaAvailable;  
REGISTERED AS {iso(1) std(0) iso8802(8802) csma(3) mauMgt(20) attribute(7)  
mauMediaAvailable(209)};

**bMediaAvailable** BEHAVIOUR  
DEFINED AS See “BEHAVIOUR DEFINED AS” in 20.2.2.1.3.;

<b>aLoseMediaCounter</b>	<b>ATTRIBUTE</b>
WITH ATTRIBUTE SYNTAX	IEEE802Dot3-MgmtAttributeModule. aRMCounter;
MATCHES FOR BEHAVIOUR	EQUALITY, ORDERING; bLoseMediaCounter;
REGISTERED AS	{iso(1) std(0) iso8802(8802) csma(3) mauMgt(20) attribute(7) mauLoseMediaCounter(201)};
<b>bLoseMediaCounter</b>	<b>BEHAVIOUR</b>
DEFINED AS	See “BEHAVIOUR DEFINED AS” in 20.2.2.1.4.;
<b>aJabber</b>	<b>ATTRIBUTE</b>
WITH ATTRIBUTE SYNTAX	IEEE802Dot3-MgmtAttributeModule. Jabber;
MATCHES FOR BEHAVIOUR	EQUALITY, ORDERING; bJabberAttribute;
REGISTERED AS	{iso(1) std(0) iso8802(8802) csma(3) mauMgt(20) attribute(7) jabber(211)};
<b>bJabberAttribute</b>	<b>BEHAVIOUR</b>
DEFINED AS	See “BEHAVIOUR DEFINED AS” in 20.2.2.1.5.;
<b>aMAUAdminState</b>	<b>ATTRIBUTE</b>
WITH ATTRIBUTE SYNTAX	IEEE802Dot3-MgmtAttributeModule. AdminState;
MATCHES FOR BEHAVIOUR	EQUALITY, ORDERING; bMAUAdminState;
REGISTERED AS	{iso(1) std(0) iso8802(8802) csma(3) mauMgt(20) attribute(7) mauAdminState(212)};
<b>bMAUAdminState</b>	<b>BEHAVIOUR</b>
DEFINED AS	See “BEHAVIOUR DEFINED AS” in 20.2.2.1.6.;
<b>aBbMAUXmitRcvSplitType</b>	<b>ATTRIBUTE</b>
WITH ATTRIBUTE SYNTAX	IEEE802Dot3-MgmtAttributeModule. BbandXmitRcvSplitType;
MATCHES FOR BEHAVIOUR	EQUALITY; bBbMAUXmitRcvSplitType;
REGISTERED AS	{iso(1) std(0) iso8802(8802) csma(3) mauMgt(20) attribute(7) bBandSplitType(213)};
<b>bBbMAUXmitRcvSplitType</b>	<b>BEHAVIOUR</b>
DEFINED AS	See “BEHAVIOUR DEFINED AS” in 20.2.2.1.7.;
<b>aBroadbandFrequencies</b>	<b>ATTRIBUTE</b>
WITH ATTRIBUTE SYNTAX	IEEE802Dot3-MgmtAttributeModule. BbandFrequency;
MATCHES FOR BEHAVIOUR	EQUALITY; bBroadbandFrequencies;
REGISTERED AS	{iso(1) std(0) iso8802(8802) csma(3) mauMgt(20) attribute(7) bBandFrequencies(214)};



<b>aLMCounter</b>	<b>ATTRIBUTE</b>
DERIVED FROM	“ISO/IEC 10165-5”:genericWrappingCounter;
BEHAVIOUR	bRMCounter;
REGISTERED AS	{iso(1) member-body(2) us(840) 802dot3(10006) csmalayermgt(5) attribute(7) lmCounter(150)};

#### H.4.2 ASN.1 module

This ASN.1 module defines the ASN.1 types and subtypes that are referred to immediately after the WITH ATTRIBUTE SYNTAX construct in this document's uses of the attribute template defined in ISO/IEC 10165-4 : 1992.

```
IEEE802Dot3-MgmtAttributeModule {iso(1) member-body(2) us(840) 802dot3(10006)
global(1) asn1Module(2) commonDefinitions(X) version(X)} DEFINITIONS IMPLICIT TAGS ::= BEGIN
```

```
EXPORTS      --everything
IMPORTS      --implicitly imports ISO 8824
    MACAddress      FROM IEEE802CommonDefinitions
                    {iso(1) member-body(2) us(840) ieee802-1partf(x) asn1Module(2)
                    commonDefinitions(0) version1(0)};
```

```
AdminState ::= ENUMERATED {
    other          (1),  --undefined
    unknown        (2),  --initializing, true state not yet known
    operational    (3),  --powered and connected
    standby        (4),  --inactive but on
    shutdown       (5),  --similar to power down
}
```

```
AttemptArray ::= SEQUENCE OF aLMCounter--array [1..attempt limit - 1]
```

```
AutoPartitionState ::= ENUMERATED {
    autoPartitioned      (1),
    notAutoPartitioned  (2)
}
```

```
BbandFrequency ::= SEQUENCE {
    xmitCarrierFrequency [1]  INTEGER , --Freq. in MHz times 4, (250 kHz resolution)
    translationFrequency [2]  INTEGER  --Freq. in MHz times 4, (250 kHz resolution)
}
```

```
BbandXmitRcvSplitType ::= ENUMERATED {
    other          (1),  --undefined
    single         (2),  --single-cable system
    dual           (3),  --dual-cable system, offset normally zero
}
```

```
BitString ::= BIT STRING (SIZE (1..1024))
```

```
Jabber ::= SEQUENCE {
    jabberFlag      [1]  JabberFlag,
    jabberCounter   [2]  JabberCounter
}
```

```
JabberFlag ::= ENUMERATED {
    other                (1),  --undefined
    unknown              (2),  --initializing, true state not yet known
    normal               (3),  --state is true or normal
    fault                (4),  --state is false, fault or abnormal
}
JabberCounter ::= INTEGER (0..232-1)

MediaAvailState ::= ENUMERATED {
    other                (1),  --undefined
    unknown              (2),  --initializing, true state not yet known
    available            (3),  --link or light normal, loopback normal
    not available        (4),  --link loss or low light, no loopback
    remote fault         (5),  --remote fault, applies only to 10BASE-FB
    invalid signal       (6),  --invalid signal, applies only to 10BASE-FB
}

MulticastAddressList ::= SEQUENCE OF MACAddress

OneOfName ::= INTEGER (1..1024)

PortAdminState ::= ENUMERATED {
    disabled             (1),
    enabled              (2)
}

RepeaterHealthData ::= OCTET STRING (SIZE (0..255))

RepeaterHealthInfo ::= SEQUENCE {
    repeaterHealthState [1] RepeaterHealthState,
    repeaterHealthText  [2] RepeaterHealthText OPTIONAL,
    repeaterHealthData  [3] RepeaterHealthData OPTIONAL
}

RepeaterHealthState ::= ENUMERATED {
    other                (1),  --undefined or unknown
    ok                  (2),  --no known failures
    repeaterFailure     (3),  --known to have a repeater-related failure
    groupFailure        (4),  --known to have a group-related failure
    portFailure         (5),  --known to have a port-related failure
    generalFailure      (6),  --has a failure condition, unspecified type
}

RepeaterHealthText ::= PrintableString (SIZE (0..255))

TrueFalse ::= BOOLEAN

TypeValue ::= ENUMERATED {
    global              (0),  --undefined
    other               (1),  --undefined
    unknown             (2),  --initializing, true state not yet known
    AUI                 (7),  --no internal MAU, view from AUI
    10BASE5             (8),  --Thick coaxial cable MAU as specified in Clause 8
    FOIRL               (9),  --FOIRL MAU as specified in 9.9
    10BASE2             (10), --Thin coaxial cable MAU as specified in Clause 10
}
```



10BROAD36	(11), --Broadband DTE MAU as specified in Clause 11
10BASE-T	(14), --UTP MAU as specified in Clause 14
10BASE-FP	(16), --Passive fiber MAU, specified in Clause 16
10BASE-FB	(17), --Synchronous fiber MAU, specified in Clause 17
10BASE-FL	(18) --Asynchronous fiber MAU, specified in Clause 18
}	

END



NOTE—This annex is numbered in correspondence to its associated clause; i.e., Annex 4A corresponds to Clause 4.

## Annex 4A

(normative)

### Simplified full duplex media access control

This annex is based on the Clause 4 MAC, with simplifications for use in networks that do not require the half duplex operational mode. Additional functionality is included for managing Physical Layer congestion and for support of interframe spacing outside this sublayer. This annex stands alone and does not rely on information within Clause 4 to be implemented.

#### 4A.1 Functional model of the MAC method

##### 4A.1.1 Overview

The architectural model described in Clause 1 is used in this clause to provide a functional description of the LAN full duplex MAC sublayer.

The MAC sublayer defines a medium-independent facility, built on the medium-dependent physical facility provided by the Physical Layer, and under the access-layer-independent LAN LLC sublayer (or other MAC client). It is applicable to a general class of media suitable for use with the full duplex media access discipline.

The LLC sublayer and the MAC sublayer together are intended to have the same function as that described in the OSI model for the Data Link Layer alone. The partitioning of functions presented in this standard requires two main functions generally associated with a data link control procedure to be performed in the MAC sublayer. They are as follows:

- a) Data encapsulation (transmit and receive)
  - 1) Framing (frame boundary delimitation, frame synchronization)
  - 2) Addressing (handling of source and destination addresses)
  - 3) Error detection (detection of physical medium transmission errors)
- b) Media access management (Physical Layer congestion)

This MAC does not support the *half duplex* mode of operation so there is no need for collision detection or handling. However, this MAC does have the ability to avoid congestion within the Physical Layer. Therefore, Media Access Management comprises the transmission of bits to the Physical Layer and optionally delaying any transmission for an interframe gap or for a longer period of time based on congestion within the Physical Layer.

An optional MAC control sublayer, architecturally positioned between LLC (or other MAC client) and the MAC, is specified in Clause 31 and Clause 64. This MAC Control sublayer is transparent to both the underlying MAC and its client (typically LLC). The MAC sublayer operates independently of its client; i.e., it is unaware whether the client is LLC or the MAC Control sublayer. This allows the MAC to be specified and implemented in one manner, whether or not the MAC Control sublayer is implemented. References to LLC as the MAC client in text and figures apply equally to the MAC Control sublayer, if implemented.

The remainder of this clause provides a functional model of this MAC method.

## 4A.1.2 Full duplex operation

This subclause provides an overview of frame transmission and reception in terms of the functional model of the architecture. This overview is descriptive, rather than definitional; the formal specifications of the operations described here are given in 4A.2 and 4A.3. Specific implementations for full duplex mechanisms that meet this standard are given in 4A.4. Figure 1-1 provides the architectural model described functionally in the subclauses that follow.

The Physical Layer Signaling (PLS) component of the Physical Layer provides an interface to the MAC sublayer for the serial transmission of bits onto the physical media. For completeness, in the operational description that follows some of these functions are included as descriptive material. The concise specification of these functions is given in 4A.2 for the MAC functions and in Clause 7 for PLS.

Transmit frame operations are independent from receive frame operations and respond to different signals from the Physical Layer. The carrierSense signal indicates that the transmit function must defer because of congestion at the Physical Layer (see 4A.2.3.2.1). The receiveDataValid signal indicates the presence of incoming data to the receive function (see 4A.2.4.2).

### 4A.1.2.1 Transmission

When a MAC client requests the transmission of a frame, the Transmit Data Encapsulation component of the full duplex MAC sublayer constructs the frame from the client-supplied data. It prepends a preamble and a Start Frame Delimiter to the beginning of the frame. Using information provided by the client, the MAC sublayer also appends a Pad at the end of the MAC information field of sufficient length to ensure that the transmitted frame length satisfies a minimum frame-size requirement (see 4A.2.3.2.4). It also prepends destination and source addresses, the length/type field, and appends a frame check sequence to provide for error detection. If the MAC supports the use of client-supplied frame check sequence values, then it shall use the client-supplied value, when present. If the use of client-supplied frame check sequence values is not supported, or if the client-supplied frame check sequence value is not present, then the MAC shall compute this value. Frame transmission may be initiated once the carrierSense signal has been removed and after the interframe delay, regardless of the presence of receive activity.

The Physical Layer performs the task of generating the signals on the medium that represent the bits of the frame. Once the Physical Layer has indicated its readiness to transmit another frame by removing the carrierSense signal, it shall accept a complete frame from the MAC layer. A functional description of the Physical Layer is given in Clause 7 and beyond.

When transmission has completed, the MAC sublayer so informs the MAC client and awaits the next request for frame transmission.

### 4A.1.2.2 Reception

At each receiving station, the arrival of a frame is first detected by the Physical Layer, which responds by synchronizing with the incoming preamble, and by turning on the receiveDataValid signal. As the encoded bits arrive from the medium, they are decoded and translated back into binary data. The Physical Layer passes subsequent bits up to the MAC sublayer, where the leading bits are discarded, up to and including the end of the preamble and Start Frame Delimiter.

Meanwhile, the Receive Media Access Management component of the MAC sublayer, having observed receiveDataValid, has been waiting for the incoming bits to be delivered. Receive Media Access Management collects bits from the Physical Layer entity as long as the receiveDataValid signal remains on. When the receiveDataValid signal is removed, the frame is truncated to an octet boundary, if necessary, and passed to Receive Data Decapsulation for processing.

Receive Data Decapsulation checks the frame's Destination Address field to decide whether the frame should be received by this station. If so, it passes the Destination Address (DA), the Source Address (SA), the Length/Type, the Data, and (optionally) the Frame Check Sequence (FCS) fields to the MAC client, along with an appropriate status code, as defined in 4A.3.2. It also checks for invalid MAC frames by inspecting the FCS to detect any damage to the frame enroute, and by checking for proper octet-boundary alignment of the end of the frame. Frames with a valid FCS may also be checked for proper octet-boundary alignment.

### 4A.1.3 Relationships to the MAC client and Physical Layers

The MAC sublayer provides services to the MAC client required for the transmission and reception of frames. Access to these services is specified in 4A.3. The MAC sublayer makes a best effort to transfer a serial stream of bits to the Physical Layer. Although certain errors are reported to the client, error recovery is not provided by MAC. Error recovery may be provided by the MAC client or higher (sub)layers.

## 4A.2 Media access control (MAC) method: precise specification

### 4A.2.1 Introduction

A precise algorithmic definition is given in this subclause, providing a procedural model for the MAC process with a program in the computer language Pascal. See references [B13] and [B24] for resource material. Note whenever there is any apparent ambiguity concerning the definition of some aspect of the MAC method, it is the Pascal procedural specification in 4A.2.7 through 4A.2.10 that should be consulted for the definitive statement. Subclauses 4A.2.2 through 4A.2.6 provide, in prose, a description of the access mechanism with the formal terminology to be used in the remaining subclauses.

### 4A.2.2 Overview of the procedural model

The functions of the MAC method are presented below, modeled as a program written in the computer language Pascal. This procedural model is intended as the primary specification of the functions to be provided in any MAC sublayer implementation. It is important to distinguish, however, between the model and a real implementation. The model is optimized for simplicity and clarity of presentation, while any realistic implementation shall place heavier emphasis on such constraints as efficiency and suitability to a particular implementation technology or computer architecture. In this context, several important properties of the procedural model shall be considered.

#### 4A.2.2.1 Ground rules for the procedural model

- a) First, it shall be emphasized that *the description of the MAC sublayer in a computer language is in no way intended to imply that procedures shall be implemented as a program executed by a computer*. The implementation may consist of any appropriate technology including hardware, firmware, software, or any combination.
- b) Similarly, it shall be emphasized that it is the behaviour of any MAC sublayer implementations that shall match the standard, not their internal structure. The internal details of the procedural model are useful only to the extent that they help specify that behaviour clearly and precisely.
- c) The handling of incoming and outgoing frames is rather stylized in the procedural model, in the sense that frames are handled as single entities by most of the MAC sublayer and are only serialized for presentation to the Physical Layer. In reality, many implementations will instead handle frames serially on a bit, octet or word basis. This approach has not been reflected in the procedural model, since this only complicates the description of the functions without changing them in any way.
- d) The model consists of algorithms designed to be executed by a number of concurrent processes; these algorithms collectively implement the MAC procedure. The timing dependencies introduced by the need for concurrent activity are resolved in two ways:

- 1) *Processes Versus External Events.* It is assumed that the algorithms are executed “very fast” relative to external events, in the sense that a process never falls behind in its work and fails to respond to an external event in a timely manner. For example, when a frame is to be received, it is assumed that the Media Access procedure ReceiveFrame is always called well before the frame in question has started to arrive.
- 2) *Processes Versus Processes.* Among processes, no assumptions are made about relative speeds of execution. This means that each interaction between two processes shall be structured to work correctly independent of their respective speeds. Note, however, that the timing of interactions among processes is often, in part, an indirect reflection of the timing of external events, in which case appropriate timing assumptions may still be made.

It is intended that the concurrency in the model reflect the parallelism intrinsic to the task of implementing the MAC client and MAC procedures, although the actual parallel structure of the implementations is likely to vary.

#### 4A.2.2.2 Use of Pascal in the procedural model

Several observations need to be made regarding the method with which Pascal is used for the model. Some of these observations are as follows:

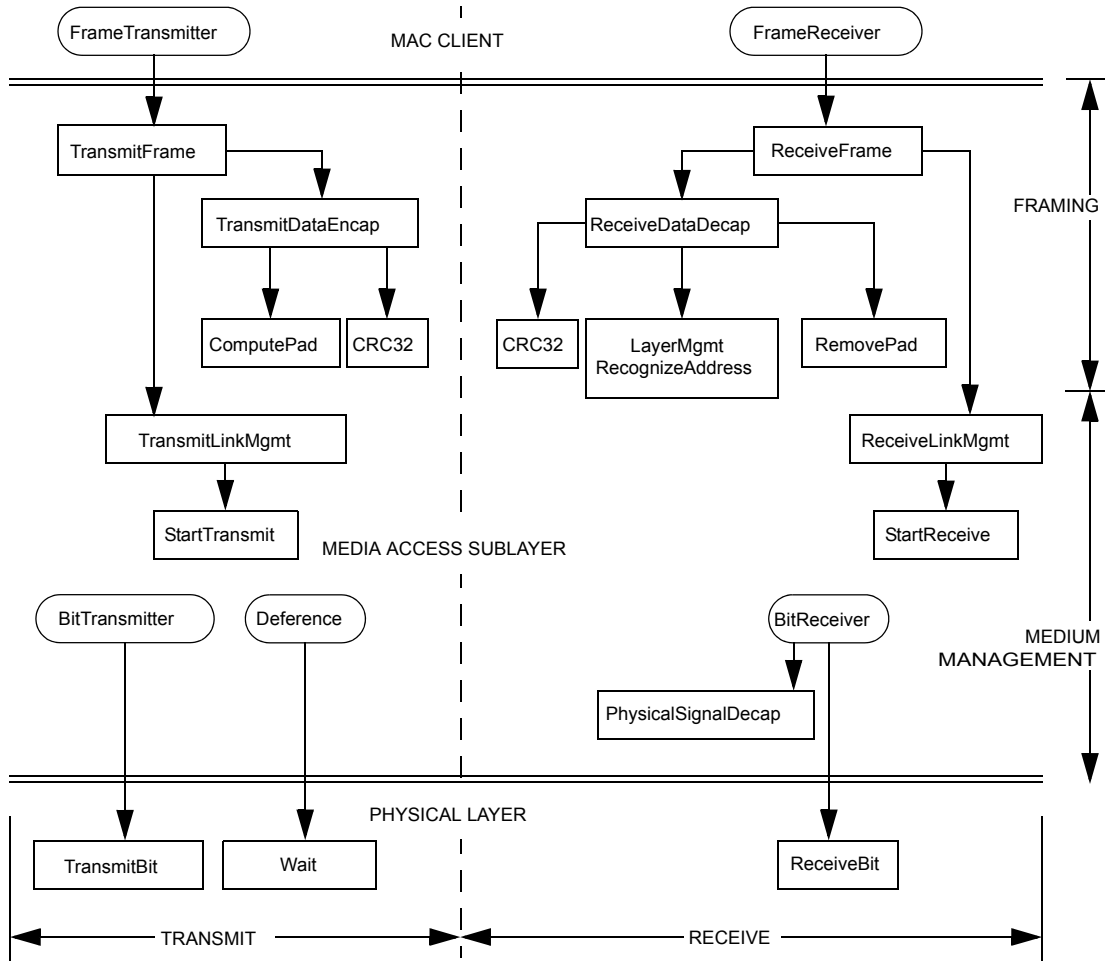
- a) The following limitations of the language have been circumvented to simplify the specification:
  - 1) The elements of the program (variables and procedures, for example) are presented in logical groupings, in top-down order. Certain Pascal ordering restrictions have thus been circumvented to improve readability.
  - 2) The *process* and *cycle* constructs of Concurrent Pascal, a Pascal derivative, have been introduced to indicate the sites of autonomous concurrent activity. As used here, a process is simply a parameterless procedure that begins execution at “the beginning of time” rather than being invoked by a procedure call. A cycle statement represents the main body of a process and is executed repeatedly forever.
  - 3) The lack of variable array bounds in the language has been circumvented by treating frames as if they are always of a single fixed size (which is never actually specified). The size of a frame depends on the size of its data field, hence the value of the “pseudo-constant” frameSize should be thought of as varying in the long term, even though it is fixed for any given frame.
  - 4) The use of a variant record to represent a frame (as fields and as bits) follows the spirit but not the letter of the Pascal Report, since it allows the underlying representation to be viewed as two different data types.
- b) The model makes no use of any explicit interprocess synchronization primitives. Instead, all interprocess interaction is done by way of carefully stylized manipulation of shared variables. For example, some variables are set by only one process and inspected by another process in such a manner that the net result is independent of their execution speeds. While such techniques are not generally suitable for the construction of large concurrent programs, they simplify the model and more nearly resemble the methods appropriate to the most likely implementation technologies (microcode, hardware state machines, etc.)

#### 4A.2.2.3 Organization of the procedural model

The procedural model used here is based on five cooperating concurrent processes. The Frame Transmitter process and the Frame Receiver process are provided by the clients of the MAC sublayer (which may include the LLC sublayer) and make use of the interface operations provided by the MAC sublayer. The other three processes are defined to reside in the MAC sublayer. The five processes are as follows:

- a) Frame Transmitter process
- b) Frame Receiver process
- c) Bit Transmitter process
- d) Bit Receiver process
- e) Deference process

This organization of the model is illustrated in Figure 4A–1 and reflects the fact that the communication of entire frames is initiated by the client of the MAC sublayer, while the timing of individual bit transfers is based on interactions between the MAC sublayer and the Physical-Layer-dependent bit time.



**Figure 4A-1—Relationship among MAC procedures**

Figure 4A-1 depicts the static structure of the procedural model, showing how the various processes and procedures interact by invoking each other. Figure 4A-2a, Figure 4A-2b, and Figure 4A-2c summarize the dynamic behaviour of the model during transmission and reception, focusing on the steps that shall be performed, rather than the procedural structure that performs them. The usage of the shared state variables is not depicted in the figures, but is described in the comments and prose in the following subclauses.

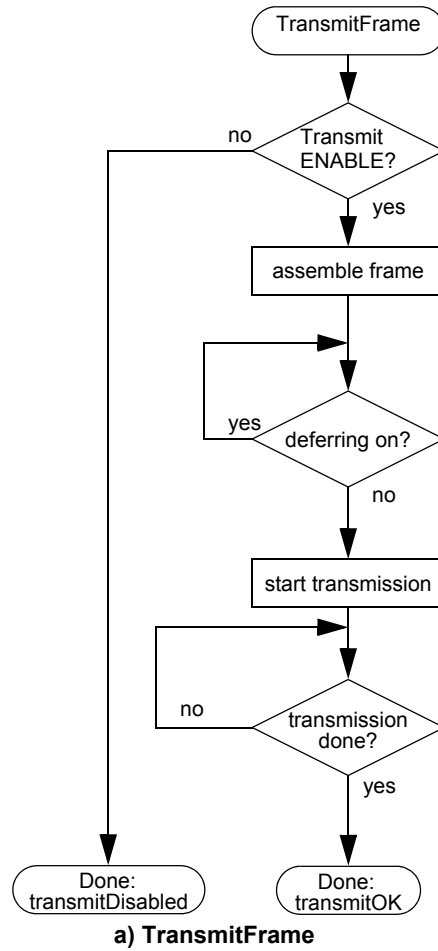
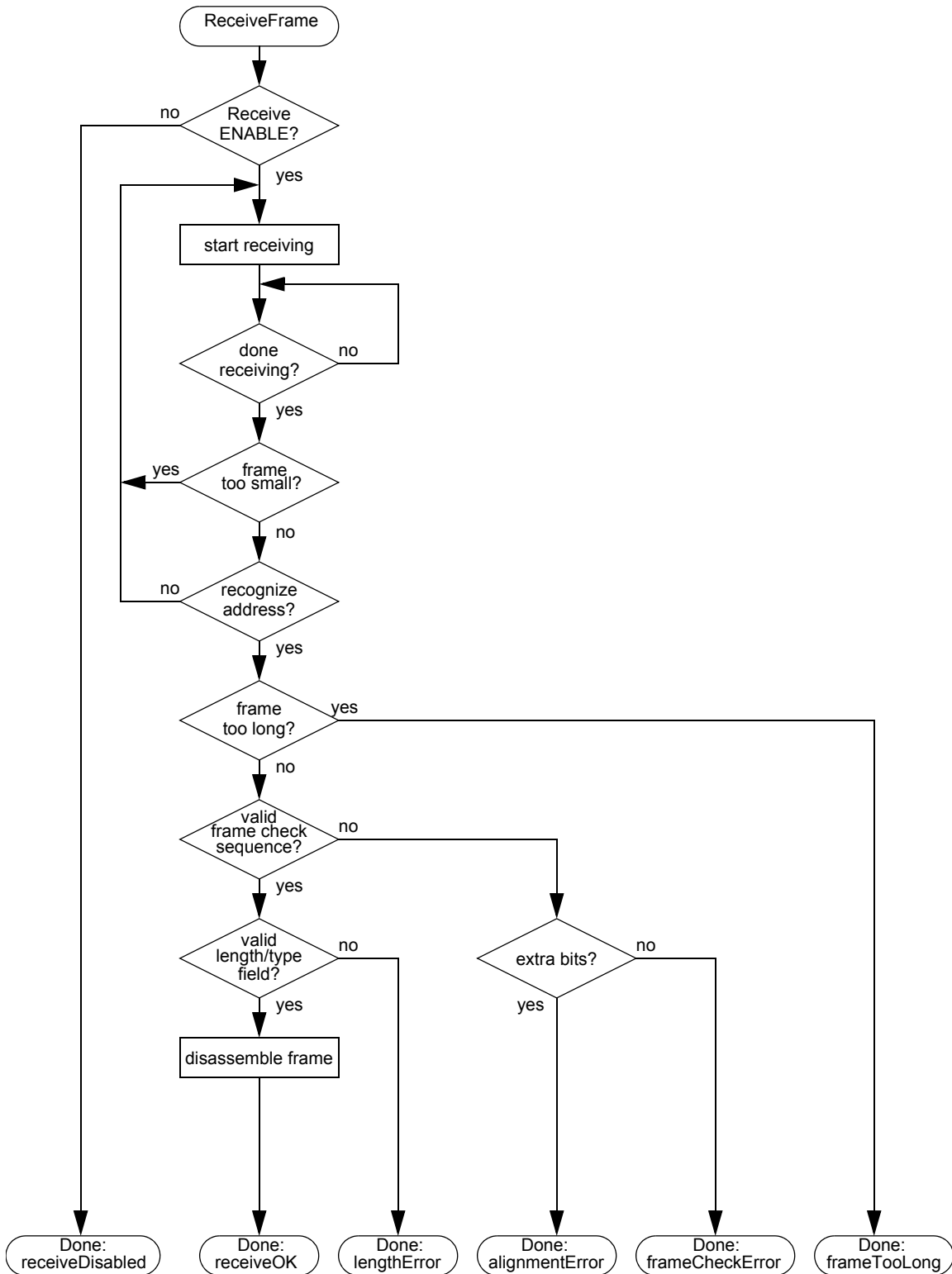


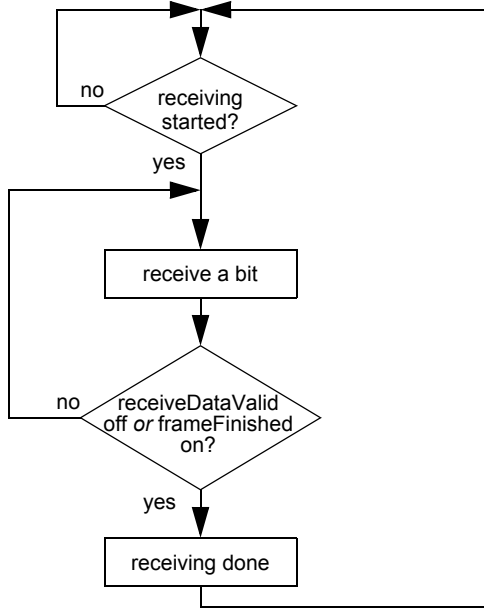
Figure 4A-2a—Control flow summary



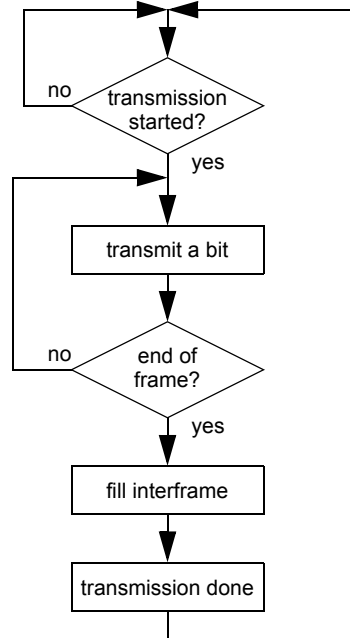


b) ReceiveFrame

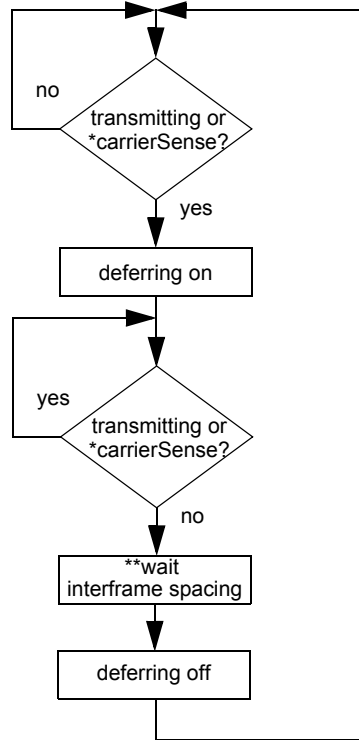
Figure 4A-2b—Control flow summary



BitReceiver process



BitTransmitter process



Deference process

\* - carrierSense is ignored when carrierSenseMode is FALSE  
 \*\* - deferring for an interframe spacing is ignored when deferenceMode is FALSE

c) MAC sublayer

Figure 4A-2c—Control flow

#### 4A.2.2.4 Layer management extensions to procedural model

In order to incorporate network management functions, this Procedural Model has been expanded beyond that provided in ISO/IEC 8802-3: 1990. Network management functions have been incorporated in two ways. First, 4A.2.7–4A.2.10, 4A.3.2, Figure 4A–2a, and Figure 4A–2b have been modified and expanded to provide management services. Second, Layer Management procedures have been added as 5.2.4. The Pascal variables are shared between Annex 4A and Clause 5.

The Pascal procedural specification shall be consulted for the definitive statement when there is any apparent ambiguity concerning the definition of some aspect of the MAC access method.

The Layer Management facilities provided by the MAC and Physical Layer management definitions provide the ability to manipulate management counters and initiate actions within the layers. The managed objects within this standard are defined as sets of attributes, actions, notifications, and behaviours in accordance with IEEE Std 802.1F-1993, and ISO/IEC International Standards for network management.

#### 4A.2.3 Packet transmission model

Packet transmission includes data encapsulation and Media Access management aspects:

- a) Transmit Data Encapsulation includes the assembly of the outgoing packet (from the values provided by the MAC client) and frame check sequence generation.
- b) Transmit Media Access Management includes carrier deference, interpacket gap and bit transmission.

##### 4A.2.3.1 Transmit data encapsulation

The fields of the MAC frame are set to the values provided by the MAC client as arguments to the TransmitFrame operation (see 4A.3) with the following possible exceptions: the padding field and the frame check sequence. The padding field is necessary to enforce the minimum frame size. The frame check sequence field may be (optionally) provided as an argument to the MAC sublayer. It is optional for a MAC to support the provision of the frame check sequence in such an argument. If this field is provided by the MAC client, the padding field shall also be provided by the MAC client, if necessary. If this field is not provided by the MAC client, or if the MAC does not support the provision of the frame check sequence as an external argument, it is set to the CRC value as generated by the MAC sublayer, after appending the padding field, if necessary.

##### 4A.2.3.2 Transmit media access management

###### 4A.2.3.2.1 Deference

When a packet is submitted by the MAC client for transmission, the transmission is initiated as soon as possible, but in conformance with the following rules. The variable carrierSense is ignored in process Deference when the variable carrierSenseMode is FALSE.

The MAC sublayer monitors the transmitting variable, which indicates the MAC is transmitting data to the Physical Layer, as well as the carrierSense signal provided by the PLS, which indicates the Physical Layer is not ready for the next frame. When either transmitting or carrierSense is true, the MAC delays any pending transmission. When both are false, the MAC continues to defer for a proper interPacketGap (see 4A.2.3.2.2).

If, at the end of the interPacketGap, a packet is waiting to be transmitted, transmission is initiated. When transmission has completed (or immediately, if there was nothing to transmit) the MAC sublayer resumes its original monitoring of transmitting and carrierSense.

#### 4A.2.3.2.2 Interpacket gap

As defined in 4A.2.3.2.1, the rules for deferring ensure a minimum interpacket spacing of `interPacketGap` bit times. This is intended to provide interframe recovery time to aid in packet delineation on the physical medium.

Note that `interPacketGap` is the minimum value of the interpacket gap. If necessary for implementation reasons, a transmitting sublayer may use a larger value with a resulting decrease in its throughput. The larger value is determined by the parameters of the implementation, see 4A.4.

#### 4A.2.3.2.3 Transmission

Transmissions may be initiated whenever the station has a frame queued, subject only to the Physical Layer congestion and interframe spacing required to allow recovery for the physical medium. In certain implementations, interframe spacing is accomplished outside this layer. These implementations are allowed to ignore the deference process and always initiate transmissions immediately, subject only to conditions enforced outside this sublayer.

#### 4A.2.3.2.4 Minimum frame size

The MAC requires that a minimum frame length of `minFrameSize` bits be transmitted. If `frameSize` is less than `minFrameSize`, then the MAC sublayer shall append extra bits in units of octets (pad), after the end of the MAC client data field but prior to calculating, and appending, the FCS (if not provided by the MAC client). The number of extra bits shall be sufficient to ensure that the frame, from the DA field through the FCS field inclusive, is at least `minFrameSize` bits. If the FCS is (optionally) provided by the MAC client, the pad shall also be provided by the MAC client. The content of the pad is unspecified.

### 4A.2.4 Frame reception model

The MAC sublayer frame reception includes both data decapsulation and Media Access management aspects:

- a) Receive data decapsulation comprises address recognition, frame check sequence validation, and frame disassembly to pass the fields of the received frame to the MAC client.
- b) Receive media access management comprises recognition of collision fragments from incoming frames and truncation of frames to octet boundaries.

#### 4A.2.4.1 Receive data decapsulation

##### 4A.2.4.1.1 Address recognition

The MAC sublayer is capable of recognizing individual and group addresses.

- a) *Individual Addresses*. The MAC sublayer recognizes and accepts any frame whose DA field contains the individual address of the station.
- b) *Group Addresses*. The MAC sublayer recognizes and accepts any frame whose DA field contains the Broadcast address.

The MAC sublayer is capable of activating some number of group addresses as specified by higher layers. The MAC sublayer recognizes and accepts any frame whose Destination Address field contains an active group address. An active group address may be deactivated.

The MAC sublayer may also provide the capability of operating in the promiscuous receive mode. In this mode of operation, the MAC sublayer recognizes and accepts all valid frames, regardless of their Destination Address field values.

#### 4A.2.4.1.2 Frame check sequence validation

FCS validation is essentially identical to FCS generation. If the bits of the incoming frame (exclusive of the FCS field itself) do not generate a CRC value identical to the one received, an error has occurred and the frame is identified as invalid.

#### 4A.2.4.1.3 Frame disassembly

Upon recognition of the Start Frame Delimiter at the end of the preamble sequence, the MAC sublayer accepts the frame. If there are no errors, the frame is disassembled and the fields are passed to the MAC client by way of the output parameters of the ReceiveFrame operation.

#### 4A.2.4.2 Receive media access management

The MAC sublayer recognizes the boundaries of an incoming MAC frame by monitoring the receiveDataValid signal provided by the Physical Layer. Two possible length errors can occur that indicate ill-framed data: the MAC frame may be too long, or its length may not be an integer number of octets.

- a) *Maximum Frame Size.* The receiving MAC sublayer is not required to enforce the MAC frame size limit, but it is allowed to truncate MAC frames longer than maxFrameSizeLimit octets (see 4.2.7.1). If optional layer management is implemented, such frames may be counted whether or not they are truncated. They may also be reported as an implementation-dependent error.

<b>CAUTION</b>
----------------

<p>It is recommended that any implementation that truncates MAC frames should invalidate those frames as they may have severely weakened error protection and may cause serious problems if forwarded to the MAC client.</p>
--

- b) *Integer Number of Octets in Frame.* Since the format of a valid MAC frame specifies an integer number of octets, only a collision or an error can produce a MAC frame with a length that is not an integer multiple of 8 bits. Complete MAC frames (that is, not rejected for being too small) that do not contain an integer number of octets are truncated to the nearest octet boundary. If frame check sequence validation detects an error in such a MAC frame, the status code alignmentError is reported

#### 4A.2.5 Preamble generation

In a LAN implementation, most of the Physical Layer components are allowed to provide valid output some number of bit times after being presented valid input signals. Thus it is necessary for a preamble to be sent before the start of data, to allow the PLS circuitry to reach its steady state. Upon request by TransmitLinkMgmt to transmit the first bit of a new frame, BitTransmitter shall first transmit the preamble, a bit sequence used for physical medium stabilization and synchronization, followed by the Start Frame Delimiter. The preamble pattern is:

10101010 10101010 10101010 10101010 10101010 10101010 10101010

The bits are transmitted in order, from left to right. The nature of the pattern is such that, for Manchester encoding, it appears as a periodic waveform on the medium that enables bit synchronization. It should be noted that the preamble ends with a 0.

#### 4A.2.6 Start frame sequence

The receiveDataValid signal is the indication to the MAC that the frame reception process should begin. Upon reception of the sequence 10101011 following the assertion of receiveDataValid, PhysicalSignalDecap shall begin passing successive bits to ReceiveLinkMgmt for passing to the MAC client.

## 4A.2.7 Global declarations

This subclause provides detailed formal specifications for the MAC sublayer. It is a specification of generic features and parameters to be used in systems implementing this media access method. 4A.4 provides values for these sets of parameters for recommended implementations of this media access mechanism.

### 4A.2.7.1 Common constants, types, and variables

The following declarations of constants, types and variables are used by the MAC frame transmission and reception sections of each MAC sublayer:

*const*

```

addressSize = 48; {In bits, in compliance with 3.2.3}
lengthOrTypeSize = 16; {In bits}
clientDataSize = ...; {In bits, size of MAC Client Data; see 4A.2.2.2, a) 3)}
padSize = ...; {In bits, = max (0, minFrameSize - (2 × addressSize + lengthOrTypeSize +
                                clientDataSize + crcSize))}

dataSize = ...; {In bits, = clientDataSize + padSize}
crcSize = 32; {In bits, 32-bit CRC}
frameSize = ...; {In bits, = 2 × addressSize + lengthOrTypeSize + dataSize + crcSize; see 4A.2.2.2, a)}
minFrameSize = ...; {In bits, see 4A.4}
maxBasicFrameSize = 1518; {In octets, see 3.2.7, 4A.4}
maxEnvelopeFrameSize = 2000; {In octets, see 3.2.7, 4A.4}
qTagPrefixSize = 4; {In octets, length of Q-tag Prefix, see 3.2.7, 4A.4}
maxFrameSizeLimit = maxBasicFrameSize or (maxBasicFrameSize + qTagPrefixSize) or
                    maxEnvelopeFrameSize; {in octets}
minTypeValue = 1536; {Minimum value of the Length/Type field for Type interpretation}
maxBasicDataSize = 1500;
                    {In octets, the maximum length of the MAC Client Data field of the basic frame.}
preambleSize = 56; {In bits, see 4A.2.5}
sfdSize = 8; {In bits, Start Frame Delimiter}
headerSize = 64; {In bits, sum of preambleSize and sfdSize}

```

*type*

```

Bit = (0, 1);
AddressValue = array [1..addressSize] of Bit;
LengthOrTypeValue = array [1..lengthOrTypeSize] of Bit;
DataValue = array [1..dataSize] of Bit; {Contains the portion of the MAC frame that starts with the first
                                         bit following the Length/Type field and ends with the last bit
                                         prior to the FCS field.}

CRCValue = array [1..crcSize] of Bit;
PreambleValue = array [1..preambleSize] of Bit;
SfdValue = array [1..sfdSize] of Bit;
ViewPoint = (fields, bits); {Two ways to view the contents of a MAC frame}
HeaderViewPoint = (headerFields, headerBits);
Frame = record {Format of MAC frame}
  case view: ViewPoint of
    fields: (
      destinationField: AddressValue;
      sourceField: AddressValue;
      lengthOrTypeField: LengthOrTypeValue;
      dataField: DataValue;
      fcsField: CRCValue);
    bits: (contents: array [1..frameSize] of Bit)
  end; {MAC frame}
Header = record {Format of Preamble and Start Frame Delimiter}
  case headerView: HeaderViewPoint of

```

```

headerFields: (
  preamble: PreambleValue;
  sfd: SfdValue);
headerBits: (headerContents: array [1..headerSize] of Bit)
end; {Defines header for MAC frame}
TransmitStatus = (transmitDisabled, transmitOK, excessiveCollisionError, lateCollisionErrorStatus);
ReceiveStatus = (receiveDisabled, receiveOK, frameTooLong, frameCheckError, lengthError,
  alignmentError);

```

#### 4A.2.7.2 Transmit state variables

The following items are specific to packet transmission. (See also 4A.4.)

```

const
  interPacketGap = ...; {In bit times, minimum gap between packets,
    see 4A.4}
var
  outgoingFrame: Frame; {The frame to be transmitted}
  outgoingHeader: Header;
  currentTransmitBit, lastTransmitBit: 1..frameSize; {Positions of current and last outgoing bits in
    outgoingFrame}

  lastHeaderBit: 1..headerSize;
  deferring: Boolean; {Implies any pending transmission must wait for the Physical Layer to be ready for
    the next packet and for the interpacket gap}
  deferenceMode: Boolean; {Indicates the desired mode of operation, and enables waiting for
    interpacket gap during the deference process}
  carrierSenseMode: Boolean; {Indicates the desired mode of operation, and enables using carrierSense
    to extend deference due to congestion in the PHY}

```

#### 4A.2.7.3 Receive state variables

The following items are specific to frame reception. (See also 4A.4.)

```

var
  incomingFrame: Frame; {The frame being received}
  receiving: Boolean; {Indicates that a frame reception is in progress}
  excessBits: 0..7; {Count of excess trailing bits beyond octet boundary}
  receiveSucceeding: Boolean; {Running indicator of whether reception is succeeding}
  validLength: Boolean; {Indicator of whether received frame has a length error}
  exceedsMaxLength: Boolean; {Indicator of whether received frame has a length longer than the
    maximum permitted length}
  passReceiveFCSSMode: Boolean; {Indicates the desired mode of operation, and enables passing of
    the frame check sequence field of all received frames from the
    MAC sublayer to the MAC client. passReceiveFCSSMode is a
    static variable}

```

#### 4A.2.7.4 State variable initialization

The procedure Initialize must be run when the MAC sublayer begins operation, before any of the processes begin execution. Initialize sets certain crucial shared state variables to their initial values. (All other global variables are appropriately reinitialized before each use.) Initialize then waits for the medium to be idle, and starts operation of the various processes.

NOTE—Care should be taken to ensure that the time from the completion of the Initialize process to when the first packet transmission begins is at least an interFrameGap.

If Layer Management is implemented, the Initialize procedure shall only be called as the result of the initializeMAC action (30.3.1.2.1).

```
procedure Initialize;  
begin  
  deferring := false;  
  transmitting := false; {An interface to Physical Layer; see below}  
  receiving := false;  
  passReceiveFCSEMode := ...; {True when enabling the passing of the frame check sequence of all  
    received frames from the MAC sublayer to the MAC client is desired and  
    supported, false otherwise}  
  deferenceMode := ...; {False for implementations that cannot rely on deference within the MAC to  
    provide an interframe gap, true otherwise}  
  carrierSenseMode := ...; {True for implementations that use carrierSense to indicate congestion in the  
    PHY, false otherwise.}  
  while ((carrierSenseMode and carrierSense) or receiveDataValid) do nothing  
  {Start execution of all processes}  
end; {Initialize}
```

#### 4A.2.8 Frame transmission

The algorithms in this subclause define MAC sublayer frame transmission. The function TransmitFrame implements the frame transmission operation provided to the MAC client.

The TransmitFrame operation is synchronous. Its duration is the entire attempt to transmit the frame; when the operation completes, transmission has either succeeded or failed, as indicated by the TransmitStatus status code.

The transmitDisabled status code indicates that the transmitter is not enabled. Successful transmission is indicated by the status code transmitOK. The codes excessiveCollisionError and lateCollisionErrorStatus are artifacts of the CSMA/CD MAC and maintained here for historical purposes. These codes are never generated by this full duplex MAC. TransmitStatus is not used by the service interface defined in 2.3.1. TransmitStatus may be used in an implementation dependent manner.

```
function TransmitFrame (  
  destinationParam: AddressValue;  
  sourceParam: AddressValue;  
  lengthOrTypeParam: LengthOrTypeValue;  
  dataParam: DataValue;  
  fcsParamValue: CRCValue;  
  fcsParamPresent: Bit): TransmitStatus;  
procedure TransmitDataEncap; {Nested procedure; see body below}  
begin  
  if transmitEnabled then  
    begin  
      TransmitDataEncap;  
      TransmitFrame := TransmitLinkMgmt  
    end  
  else TransmitFrame := transmitDisabled  
end; {TransmitFrame}
```



If transmission is enabled, TransmitFrame calls the internal procedure TransmitDataEncap to construct the frame. Next, TransmitLinkMgmt is called to perform the actual transmission. The TransmitStatus returned indicates the success or failure of the transmission attempt.

TransmitDataEncap builds the frame and places the 32-bit CRC in the frame check sequence field:

```

procedure TransmitDataEncap;
begin
  with outgoingFrame do
    begin {Assemble frame}
      view := fields;
      destinationField := destinationParam;
      sourceField := sourceParam;
      lengthOrTypeField := lengthOrTypeParam;
      if fcsParamPresent then
        begin
          dataField := dataParam; {No need to generate pad if the FCS is passed from MAC client}
          fcsField := fcsParamValue {Use the FCS passed from MAC client}
        end
      else
        begin
          dataField := ComputePad(dataParam);
          fcsField := CRC32(outgoingFrame)
        end;
      view := bits
    end {Assemble frame}
  with outgoingHeader do
    begin
      headerView := headerFields;
      preamble := ...; {* '1010...10,' LSB to MSB*}
      sfd := ...; {* '10101011,' LSB to MSB*}
      headerView := headerBits
    end
  end; {TransmitDataEncap}

```

If the MAC client chooses to generate the frame check sequence field for the frame, it passes this field to the MAC sublayer via the fcsParamValue parameter. If the fcsParamPresent parameter is true, TransmitDataEncap uses the fcsParamValue parameter as the frame check sequence field for the frame. Such a frame shall not require any padding, since it is the responsibility of the MAC client to ensure that the frame meets the minFrameSize constraint. If the fcsParamPresent parameter is false, the fcsParamValue parameter is unspecified. TransmitDataEncap first calls the ComputePad function, followed by a call to the CRC32 function to generate the padding (if necessary) and the frame check sequence field for the frame internally to the MAC sublayer.

ComputePad appends an array of arbitrary bits to the MAC client data to pad the frame to the minimum frame size:

```

function ComputePad(var dataParam: DataValue): DataValue;
begin
  ComputePad := {Append an array of size padSize of arbitrary bits to the MAC client dataField}
end; {ComputePad}

```

TransmitLinkMgmt attempts to transmit the frame. When deferenceMode is true, it first defers to the Physical Layer if it is not ready for the next packet and to ensure proper interframe spacing. When deferenceMode is false, it begins transmitting immediately:

```

function TransmitLinkMgmt: TransmitStatus;
begin
  while deferring do nothing {Defer to Physical Layer congestion and IFS}
  StartTransmit;
  while transmitting do nothing
  LayerMgmtTransmitCounters; {Update transmit and transmit error counters in 5.2.4.2}
  TransmitLinkMgmt := transmitOK
end; {TransmitLinkMgmt}

```

Each time a frame transmission attempt is initiated, StartTransmit is called to alert the BitTransmitter process that bit transmission should begin:

```

procedure StartTransmit;
begin
  currentTransmitBit := 1;
  lastTransmitBit := frameSize;
  lastHeaderBit := headerSize;
  transmitting := true
end; {StartTransmit}

```

The Deference process runs asynchronously to continuously compute the proper value for the variable deferring:

```

process Deference;
begin
  cycle {Main loop}
  while (not transmitting and not (carrierSenseMode and carrierSense)) do nothing; {Wait for the start
  of transmission or congestion}

  deferring := true; {Inhibit future transmissions}
  while (transmitting or (carrierSenseMode and carrierSense)) do nothing; {Wait for the end of
  transmission and congestion}

  if deferenceMode then Wait(interPacketGap);
  {Time out entire interpacket gap if enabled}
  deferring := false {Don't inhibit transmission}
  end {Main loop}
end; {Deference}

```

The BitTransmitter process runs asynchronously, transmitting bits at a rate determined by the Physical Layer's TransmitBit operation:

```

process BitTransmitter;
begin
  cycle {Outer loop}
  if transmitting then
  begin {Inner loop}
    while (currentTransmitBit ≤ lastHeaderBit) do
    begin
      TransmitBit(outgoingHeader[currentTransmitBit]);
      currentTransmitBit := currentTransmitBit + 1
    end;
    currentTransmitBit := 1;
    while transmitting do
    begin
      TransmitBit(outgoingFrame[currentTransmitBit]);
      currentTransmitBit := currentTransmitBit + 1;
      transmitting := (currentTransmitBit ≤ lastTransmitBit)
    end
  end

```

```

        end {Inner loop}
    end {Outer loop}
end; {BitTransmitter}

```

#### 4A.2.9 Frame reception

The algorithms in this subclause define the MAC sublayer frame reception.

The function `ReceiveFrame` implements the frame reception operation provided to the MAC client.

The `ReceiveFrame` operation is synchronous. The operation does not complete until a frame has been received. The fields of the frame are delivered via the output parameters with the `ReceiveStatus` status code.

The `receiveDisabled` status indicates that the receiver is not enabled. Successful reception is indicated by the status code `receiveOK`. The `frameTooLong` error indicates that the last frame received had a `frameSize` beyond the maximum allowable frame size. The code `frameCheckError` indicates that the frame received was damaged by a transmission error. The `lengthError` indicates that the `lengthOrTypeParam` value was both consistent with a length interpretation of this field (i.e., its value was less than or equal to `maxValidFrame`), and inconsistent with the `frameSize` of the received frame. The code `alignmentError` indicates that the frame received was damaged, and that in addition, its length was not an integer number of octets. `ReceiveStatus` is not mapped to any MAC client parameter by the service interface defined in 2.3.2. `ReceiveStatus` may be used in an implementation dependent manner.

```

function ReceiveFrame (
    var destinationParam: AddressValue;
    var sourceParam: AddressValue;
    var lengthOrTypeParam: LengthOrTypeValue;
    var dataParam: DataValue;
    var fcsParamValue: CRCValue;
    var fcsParamPresent: Bit): ReceiveStatus;

function ReceiveDataDecap: ReceiveStatus; {Nested function; see body below}
begin
    if receiveEnabled then
        repeat
            ReceiveLinkMgmt;
            ReceiveFrame := ReceiveDataDecap;
        until receiveSucceeding
    else ReceiveFrame := receiveDisabled
end; {ReceiveFrame}

```

If enabled, `ReceiveFrame` calls `ReceiveLinkMgmt` to receive the next valid frame, and then calls the internal function `ReceiveDataDecap` to return the frame's fields to the MAC client if the frame's address indicates that it should do so. The returned `ReceiveStatus` indicates the presence or absence of detected transmission errors in the frame.

```

function ReceiveDataDecap: ReceiveStatus;
    var status: ReceiveStatus; {Holds receive status information}
begin
    with incomingFrame do
        begin
            view := fields;
            receiveSucceeding := LayerMgmtRecognizeAddress(destinationField);
            if receiveSucceeding then

```

```

begin {Disassemble MAC frame}
  destinationParam := destinationField;
  sourceParam := sourceField;
  lengthOrTypeParam := lengthOrTypeField;
  dataParam := RemovePad(lengthOrTypeField, dataField);
  fcsParamValue := fcsField;
  fcsParamPresent := passReceiveFCSType;
  exceedsMaxLength := ...; {Check to determine if received MAC frame size exceeds
                             maxFrameSizeLimit.
                             MAC implementations use maxFrameSizeLimit to
                             determine if management counts the frame as too long.
                             It is recommended that new implementations support
                             maxFrameSizeLimit = maxEnvelopeFrameSize }
  if exceedsMaxLength then status := frameTooLong
  else if fcsField = CRC32(incomingFrame) then
    if validLength then status := receiveOK else status := lengthError
  else if excessBits = 0 then status := frameCheckError
  else status := alignmentError;
  LayerMgmtReceiveCounters(status); {Update receive counters in 5.2.4.3}
  view := bits
end {Disassemble MAC frame}
end; {With incomingFrame}
ReceiveDataDecap := status
end; {ReceiveDataDecap}

```

```

function LayerMgmtRecognizeAddress(address: AddressValue): Boolean;
begin
  if {promiscuous receive enabled} then LayerMgmtRecognizeAddress := true;
  else if address = ... {MAC station address} then LayerMgmtRecognizeAddress := true;
  else if address = ... {Broadcast address} then LayerMgmtRecognizeAddress := true;
  else if address = ... {One of the addresses on the multicast list and multicast reception is enabled} then
    LayerMgmtRecognizeAddress := true;
  else LayerMgmtRecognizeAddress := false
end; {LayerMgmtRecognizeAddress}

```

The function RemovePad strips any padding that was generated to meet the minFrameSize constraint, if possible. When the MAC sublayer operates in the mode that enables passing of the frame check sequence field of all received MAC frames to the MAC client (passReceiveFCSType variable is true), it shall not strip the padding and it shall leave the data field of the MAC frame intact. Length checking is provided for Length interpretations of the Length/Type field. For Length/Type field values in the range between maxBasicDataSize and minTypeValue the behavior of the RemovePad function is unspecified:

```

function RemovePad(var lengthOrTypeParam: LengthOrTypeValue; dataParam: DataValue): DataValue;
begin
  if lengthOrTypeParam ≥ minTypeValue then
    begin
      validLength := true; {Don't perform length checking for Type field interpretations}
      RemovePad := dataParam
    end
  else if lengthOrTypeParam ≤ maxBasicDataSize then
    begin
      validLength := {For length interpretations of the Length/Type field, check to determine if value
                     represented by Length/Type field matches the received clientDataSize};
      if validLength and not passReceiveFCSType then

```

```

        RemovePad := {Truncate the dataParam (when present) to the value represented by the
                        lengthOrTypeParam (in octets) and return the result}
    else RemovePad := dataParam
    end
end; {RemovePad}

```

ReceiveLinkMgmt attempts repeatedly to receive the bits of a frame, discarding any fragments smaller than the minimum valid frame size:

```

procedure ReceiveLinkMgmt;
begin
    repeat
        StartReceive;
        while receiving do nothing; {Wait for frame to finish arriving}
        excessBits := frameSize mod 8;
        frameSize := frameSize – excessBits; {Truncate to octet boundary}
        receiveSucceeding := (frameSize ≥ minFrameSize) {Reject frames too small}
    until receiveSucceeding
end; {ReceiveLinkMgmt}

procedure StartReceive;
begin
    receiving := true
end; {StartReceive}

```

The BitReceiver process runs asynchronously, receiving bits from the medium at the rate determined by the Physical Layer's ReceiveBit operation, partitioning them into frames, and optionally receiving them:

```

process BitReceiver;
    var b: Bit;
        currentReceiveBit: 1..frameSize; {Position of current bit in incomingFrame}
begin
    cycle {Outer loop}
        if receiveEnabled then
            begin {Receive next frame from Physical Layer}
                currentReceiveBit := 1;
                PhysicalSignalDecap; {Skip idle, strip off preamble and sfd}
                while receiveDataValid do
                    begin {Inner loop to receive the rest of an incoming frame}
                        b := ReceiveBit; {Next bit from physical medium}
                        if receiving then {Append to frame}
                            begin
                                incomingFrame[currentReceiveBit] := b;
                                currentReceiveBit := currentReceiveBit + 1
                            end; {append bit to frame}
                        receiving := receiveDataValid
                    end; {Inner loop}
                    frameSize := currentReceiveBit – 1
                end {Enabled}
            end {Outer loop}
end; {BitReceiver}

procedure PhysicalSignalDecap;
begin
    {Receive one bit at a time from physical medium until a valid sfd is detected, discard bits and return}
end; {PhysicalSignalDecap}

```

### 4A.2.10 Common procedures

The function CRC32 is used by both the transmit and receive algorithms to generate a 32-bit CRC value:

```
function CRC32(f: Frame): CRCValue;  
begin  
    CRC32 := {The 32-bit CRC for the entire frame as defined in 3.2.8, excluding the FCS field (if  
              present)}  
end; {CRC32}
```

Purely to enhance readability, the following procedure is also defined:

```
procedure nothing; begin end;
```

The idle state of a process (that is, while waiting for some event) is cast as repeated calls on this procedure.

## 4A.3 Interfaces to/from adjacent layers

### 4A.3.1 Overview

The purpose of this clause is to provide precise definitions of the interfaces between the architectural layers defined in Clause 1 in compliance with the Media Access Service Specification given in Clause 2. In addition, the services required from the physical medium are defined.

The notation used here is the Pascal language, in keeping with the procedural nature of the precise MAC sublayer specification (see 4A.2). Each interface is described as a set of procedures or shared variables, or both, that collectively provide the only valid interactions between layers. The accompanying text describes the meaning of each procedure or variable and points out any implicit interactions among them.

The description of the interfaces in Pascal is a notational technique, and in no way implies that they can or should be implemented in software. This point is discussed more fully in 4A.2, that provides complete Pascal declarations for the data types used in the remainder of this clause. The synchronous (one frame at a time) nature of the frame transmission and reception operations is a property of the architectural interface between the MAC client and MAC sublayers, and need not be reflected in the implementation interface between a station and its sublayer.

### 4A.3.2 MAC service

The services provided to the MAC client by the MAC sublayer are transmission and reception of MAC frames using service primitives MA\_DATA.request and MA\_DATA.indication, as defined in Clause 2. For historical reasons the MAC sublayer definitions use two functions, TransmitFrame and ReceiveFrame, defined in 4A.2.8 and 4A.2.9. The relationship between these two functions and the service primitives is defined by the MAC client state diagrams in 4A.3.2.1 and 4A.3.2.2.

#### 4A.3.2.1 MAC client transmit interface state diagram

##### 4A.3.2.1.1 Variables

*data*  
The value of mac\_service\_data\_unit excluding the first two octets (Length/Type field).

*destination\_address*  
The Destination Address field parsed from the client request.

*fcsPresent*  
Indicates whether the MA\_DATA.request service primitive contained the frame\_check\_sequence field.

*frame\_check\_sequence*  
The fcs field parsed from the client request.

**lengthOrType**

The value of the first two octets at the start of the `mac_service_data_unit`.

**mac\_service\_data\_unit**

The concatenation of the `lengthOrType` field and the data field parsed from the client request.

**source\_address**

The Source Address field parsed from the client request.

**TransmitStatus**

Indicates the status of the transmitted MAC frame. See 4.2.8.

**4A.3.2.1.2 Functions****TransmitFrame**

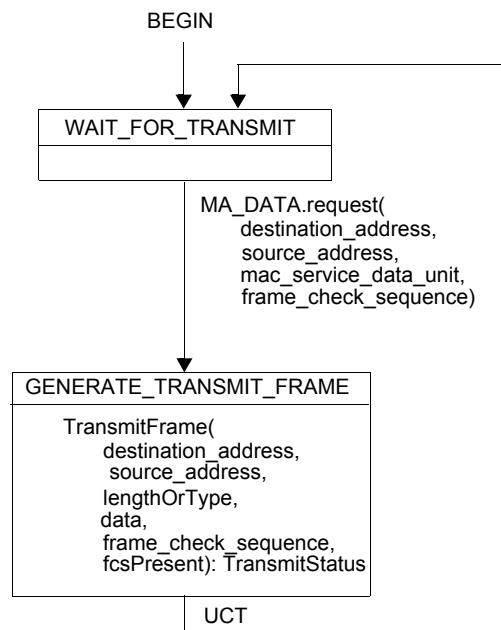
The MAC sublayer function invoked to transmit a MAC frame with the specified parameters. See 4A.2.8.

**4A.3.2.1.3 Messages****MA\_DATA.request**

The service primitive used to convey a MAC frame to be transmitted from the MAC client. See 2.3.1.

**4A.3.2.1.4 MAC client transmit interface state diagram**

Figure 4A-3 specifies the behavior of the transmit interface from the MAC client.



**Figure 4A-3—MAC client transmit interface state diagram**

**4A.3.2.2 MAC client receive interface state diagram****4A.3.2.2.1 Variables****destination\_address**

The Destination Address field parsed from the received MAC frame.

- source\_address  
The Source Address field parsed from the received MAC frame.
- lengthOrType  
The lengthOrType field parsed from the received MAC frame.
- data  
The data payload field parsed from the received MAC frame.
- fcsPresent  
A Boolean set by the MAC sublayer.
- ReceiveStatus  
Indicates the status of the received MAC frame.
- mac\_service\_data\_unit  
The concatenation of the lengthOrType field and the data field parsed from the received MAC frame.
- frame\_check\_sequence  
The fcs field parsed from the received MAC frame.

**4A.3.2.2.2 Functions**

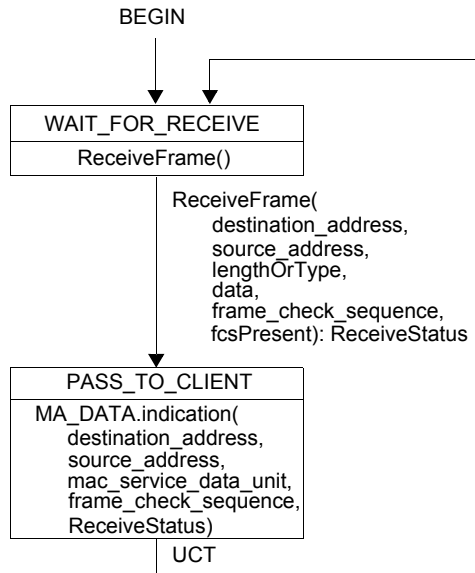
- ReceiveFrame  
The MAC sublayer function invoked to accept an incoming MAC frame with the specified parameters. See 4A.2.9.

**4A.3.2.2.3 Messages**

- MA\_DATA.indication  
The service primitive used to transfer an incoming MAC frame to the MAC client with the specified parameters. See 2.3.2.

**4A.3.2.2.4 MAC client receive interface state diagram**

Figure 4A-4 specifies the behavior of the receive interface to the MAC client.



**Figure 4A-4—MAC client receive interface state diagram**



### 4A.3.3 Services required from the Physical Layer

The interface through which the MAC sublayer uses the facilities of the Physical Layer consists of a function, a pair of procedures and four Boolean variables as described in Table 4A–1.

**Table 4A–1—Full duplex MAC functions, procedures and variables**

Function	Procedures	Variables
<b>ReceiveBit</b>	<b>TransmitBit</b>	<b>collisionDetect</b>
	<b>Wait</b>	<b>carrierSense</b>
		<b>receiveDataValid</b>
		<b>transmitting</b>

During transmission, the contents of an outgoing frame are passed from the MAC sublayer to the Physical Layer by way of repeated use of the TransmitBit operation:

*procedure* TransmitBit (bitParam: Bit);

Each invocation of TransmitBit passes one new bit of the outgoing frame to the Physical Layer. The TransmitBit operation is synchronous. The duration of the operation is the entire transmission of the bit. The operation completes when the Physical Layer is ready to accept the next bit and it transfers control to the MAC sublayer.

The overall event of data being transmitted is signaled to the Physical Layer by way of the variable transmitting:

*var* transmitting: Boolean;

Before sending the first bit of a frame, the MAC sublayer sets transmitting to true, to inform the Physical Layer that a stream of bits will be presented via the TransmitBit operation. After the last bit of the frame has been presented, the MAC sublayer sets transmitting to false to indicate the end of the frame.

The collisionDetect variable is not used by this full duplex MAC but maintained as an artifact of the CSMA/CD MAC's interface to the Physical Layer.

*var* collisionDetect: Boolean;

During reception, the contents of an incoming frame are retrieved from the Physical Layer by the MAC sublayer via repeated use of the ReceiveBit operation:

*function* ReceiveBit: Bit;

Each invocation of ReceiveBit retrieves one new bit of the incoming frame from the Physical Layer. The ReceiveBit operation is synchronous. Its duration is the entire reception of a single bit. Upon receiving a bit, the MAC sublayer shall immediately request the next bit until all bits of the frame have been received (see 4A.2 for details).

The overall event of data being received is signaled to the MAC sublayer by the variable receiveDataValid:

*var* receiveDataValid: Boolean;

When the Physical Layer sets receiveDataValid to true, the MAC sublayer shall immediately begin retrieving the incoming bits by the ReceiveBit operation. When receiveDataValid subsequently becomes false, the MAC sublayer can begin processing the received bits as a completed frame. If an invocation of ReceiveBit is pending when receiveDataValid becomes false, ReceiveBit returns an undefined value, which should be discarded by the MAC sublayer (see 4A.2 for details).

The overall event of congestion at the Physical Layer, indicating that the Physical Layer is not ready to accept the next packet, is signaled to the MAC sublayer by the variable carrierSense:

*var* carrierSense: Boolean;

When the value of variable carrierSenseMode is set to TRUE, the MAC sublayer shall monitor the value of carrierSense to defer its own transmissions when the Physical Layer is busy. The Physical Layer sets carrierSense to true immediately upon congestion within the Physical Layer. After the congestion ceases, carrierSense is set to false. When the value of variable carrierSenseMode is set to FALSE, the carrierSense variable is ignored by the MAC.

While the label carrierSense does not accurately describe the condition presented by this variable, the name is maintained as an artifact of the CSMA/CD MAC interface to the Physical Layer.

The Physical Layer also provides the procedure Wait:

*procedure* Wait (bitTimes: integer);

This procedure waits for the specified number of bit times. This allows the MAC sublayer to measure time intervals in units of the (physical-medium-dependent) bit time.

## 4A.4 Specific implementations

### 4A.4.1 Compatibility overview

To provide total compatibility at all levels of the standard, it is required that each network component implementing the MAC sublayer procedure adheres rigidly to these specifications. The information provided in 4A.4.2 provides design parameters for specific implementations of this access method. Variations from these values result in a system implementation that violates the standard. See the warning in 4A.4.2.

### 4A.4.2 MAC parameters

The parameter values shown in Table 4A–2 shall be used.

**Table 4A–2—Full duplex MAC parameter values**

Parameters	Values
interPacketGap	96 bits
maxBasicFrameSize	1518 octets
maxEnvelopeFrameSize	2000 octets
minFrameSize	512 bits (64 octets)

The minimum interPacketGap shall be enforced in this sublayer, when the deferenceMode variable is set to TRUE, or outside this sublayer, when the deferenceMode variable is set to FALSE.

NOTE 1—For 10 Mb/s operation, the spacing between two successive non-colliding packets, from start of idle at the end of the first packet to start of Preamble of the subsequent packet, can have a minimum value of 47 BT (bit times), at the AUI receive line of the DTE. This interPacketGap shrinkage is caused by variable network delays, added preamble bits, and clock skew.

NOTE 2—For 1 Gb/s operation, the spacing between two non-colliding packets, from the last bit of the FCS field of the first packet to the first bit of the Preamble of the second packet, can have a minimum value of 64 BT (bit times), as measured at the GMII receive signals at the DTE. This interPacketGap shrinkage may be caused by variable network delays, added preamble bits, and clock tolerances.

NOTE 3—For 10 Gb/s operation, the spacing between two packets, from the last bit of the FCS field of the first packet to the first bit of the Preamble of the second packet, can have a minimum value of 40 BT (bit times), as measured at the XGMII receive signals at the DTE. This interPacketGap shrinkage may be caused by variable network delays and clock tolerances.

**WARNING**

Any deviation from the above specified values may affect proper operation of the network.