



Site-to-Site and Extranet VPN Business Scenarios

This chapter explains the basic tasks for configuring IP-based, site-to-site and extranet Virtual Private Networks (VPNs) on a Cisco 7200 series router using generic routing encapsulation (GRE) and IPSec tunneling protocols. Basic security, Network Address Translation (NAT), Encryption, Cisco IOS weighted fair queuing (WFQ), and extended access lists for basic traffic filtering are configured.



Note

In this Guide, the term ‘Cisco 7200 series router’ implies that an Integrated Service Adaptor (ISA) or a VAM (VAM, VAM2, or VAM2+) is installed in the Cisco 7200 series router.

This chapter describes basic features and configurations used in a site-to-site VPN scenario. Some Cisco IOS security software features not described in this document can be used to increase performance and scalability of your VPN. For up-to-date Cisco IOS security software features documentation, refer to the *Cisco IOS Security Configuration Guide* and the *Cisco IOS Security Command Reference* publications for your Cisco IOS Release. For information on how to access the publications, see “[Related Documentation](#)” section on page x.

This chapter includes the following sections:

- [Scenario Descriptions, page 3-2](#)
- [Step 1—Configuring the Tunnel, page 3-6](#)
- [Step 2—Configuring Network Address Translation, page 3-10](#)
- [Step 3—Configuring Encryption and IPSec, page 3-14](#)
- [Step 4—Configuring Quality of Service, page 3-28](#)
- [Step 5—Configuring Cisco IOS Firewall Features, page 3-36](#)
- [Comprehensive Configuration Examples, page 3-39](#)



Note

Throughout this chapter, there are numerous configuration examples and sample configuration outputs that include unusable IP addresses. Be sure to use your own IP addresses when configuring your Cisco 7200 series router.

Scenario Descriptions

This section includes the following topics:

- [Site-to-Site Scenario, page 3-2](#)
- [Extranet Scenario, page 3-4](#)
- [Configuring a GRE Tunnel, page 3-7](#)
- [Configuring an IPsec Tunnel, page 3-9](#)
- [Configuring Static Inside Source Address Translation, page 3-13](#)
- [Verifying Static Inside Source Address Translation, page 3-13](#)
- [Configuring IKE Policies, page 3-15](#)
- [Verifying IKE Policies, page 3-19](#)
- [Configuring IPsec and IPsec Tunnel Mode, page 3-22](#)
- [Configuring Crypto Maps, page 3-24](#)
- [Configuring Network-Based Application Recognition, page 3-29](#)
- [Configuring Weighted Fair Queuing, page 3-32](#)
- [Verifying Weighted Fair Queuing, page 3-33](#)
- [Configuring Class-Based Weighted Fair Queuing, page 3-33](#)
- [Verifying Class-Based Weighted Fair Queuing, page 3-36](#)
- [Creating Extended Access Lists Using Access List Numbers, page 3-37](#)
- [Verifying Extended Access Lists, page 3-38](#)
- [Applying Access Lists to Interfaces, page 3-38](#)
- [Verifying Extended Access Lists Are Applied Correctly, page 3-39](#)

Site-to-Site Scenario

Figure 3-1 shows a headquarters network providing a remote office access to the corporate intranet. In this scenario, the headquarters and remote office are connected through a secure GRE tunnel that is established over an IP infrastructure (the Internet). Employees in the remote office are able to access internal, private web pages and perform various IP-based network tasks.

**Note**

Although the site-to-site VPN scenario in this chapter is configured with GRE tunneling, a site-to-site VPN can also be configured with IPsec only tunneling.

Figure 3-1 Site-to-Site VPN Business Scenario

Figure 3-2 shows the physical elements of the scenario. The Internet provides the core interconnecting fabric between the headquarters and remote office routers. Both the headquarters and remote office are using a Cisco IOS VPN gateway (a Cisco 7200 series with an Integrated Service Adaptor (ISA) or VAM (VAM, VAM2, or VAM2+), a Cisco 2600 series router, or a Cisco 3600 series router).

**Note**

VPN Acceleration Module (VAM) information for your Cisco 7200 series router can be found at http://www.cisco.com/en/US/products/hw/routers/ps341/products_installation_and_configuration_guides_list.html.

The GRE tunnel is configured on the first serial interface in chassis slot 1 (serial 1/0) of the headquarters and remote office routers. Fast Ethernet interface 0/0 of the headquarters router is connected to a corporate server and Fast Ethernet interface 0/1 is connected to a web server. Fast Ethernet interface 0/0 of the remote office router is connected to a PC client.

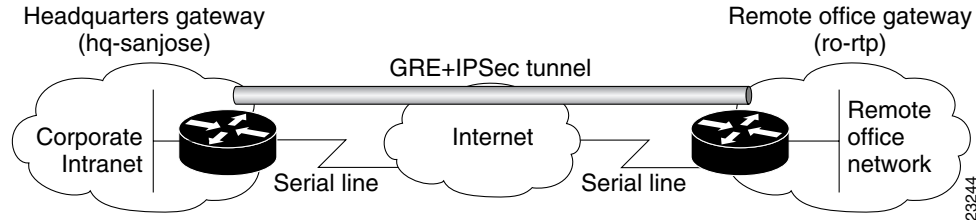
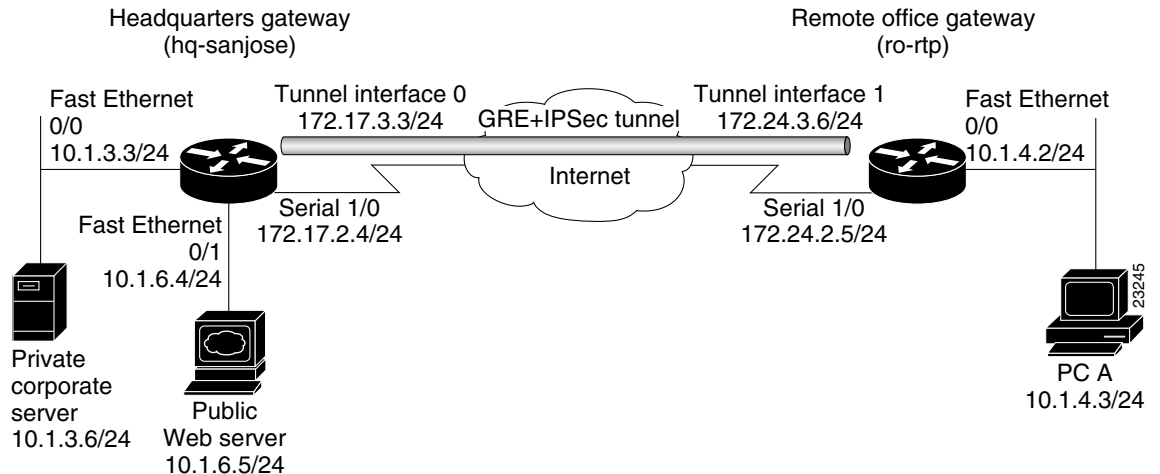
Figure 3-2 Site-to-Site VPN Scenario Physical Elements

The configuration steps in the following sections are for the headquarters router, unless noted otherwise. Comprehensive configuration examples for both the headquarters and remote office routers are provided in the “Comprehensive Configuration Examples” section on page 3-39.

Table 3-1 lists the physical elements of the site-to-site scenario.

Table 3-1 Physical Elements

Headquarters Network			Remote Office Network		
Site Hardware	WAN IP Address	Ethernet IP Address	Site Hardware	WAN IP Address	Ethernet IP Address
hq-sanjose	Serial interface 1/0: 172.17.2.4 255.255.255.0	Fast Ethernet Interface 0/0: 10.1.3.3 255.255.255.0	ro-rtp	Serial interface 1/0: 172.24.2.5 255.255.255.0	Fast Ethernet Interface 0/0: 10.1.4.2 255.255.255.0
	Tunnel interface 0: 172.17.3.3 255.255.255.0	Fast Ethernet Interface 0/1: 10.1.6.4 255.255.255.0		Tunnel interface 1: 172.24.3.6 255.255.255.0	
Corporate server	—	10.1.3.6	PC A	—	10.1.4.3
Web server	—	10.1.6.5			

Extranet Scenario

The extranet scenario introduced in Figure 3-3 builds on the site-to-site scenario by providing a business partner access to the same headquarters network. In the extranet scenario, the headquarters and business partner are connected through a secure IPSec tunnel and the business partner is given access only to the headquarters public server to perform various IP-based network tasks, such as placing and managing product orders.

Figure 3-3 Extranet VPN Business Scenario

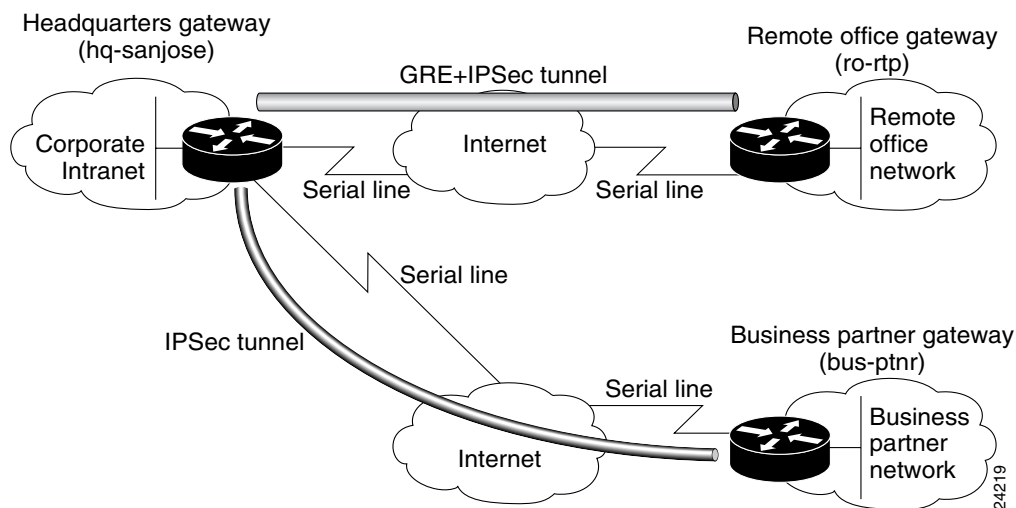

Figure 3-4 shows the physical elements of the scenario. As in the site-to-site business scenario, the Internet provides the core interconnecting fabric between the headquarters and business partner routers. Like the headquarters office, the business partner is also using a Cisco IOS VPN gateway (a Cisco 7200 series with an Integrated Service Adaptor (ISA) or VAM (VAM, VAM2, or VAM2+), a Cisco 2600 series router, or a Cisco 3600 series router).

**Note**

VPN Acceleration Module (VAM) information for your Cisco 7200 series router can be found at http://www.cisco.com/en/US/products/hw/routers/ps341/products_installation_and_configuration_guides_list.html.

The IPSec tunnel between the two sites is configured on the second serial interface in chassis slot 2 (serial 2/0) of the headquarters router and the first serial interface in chassis slot 1 (serial 1/0) of the business partner router. Fast Ethernet interface 0/0 of the headquarters router is still connected to a private corporate server and Fast Ethernet interface 0/1 is connected to a public server. Fast Ethernet interface 0/0 of the business partner router is connected to a PC client.

Figure 3-4 Extranet VPN Scenario Physical Elements

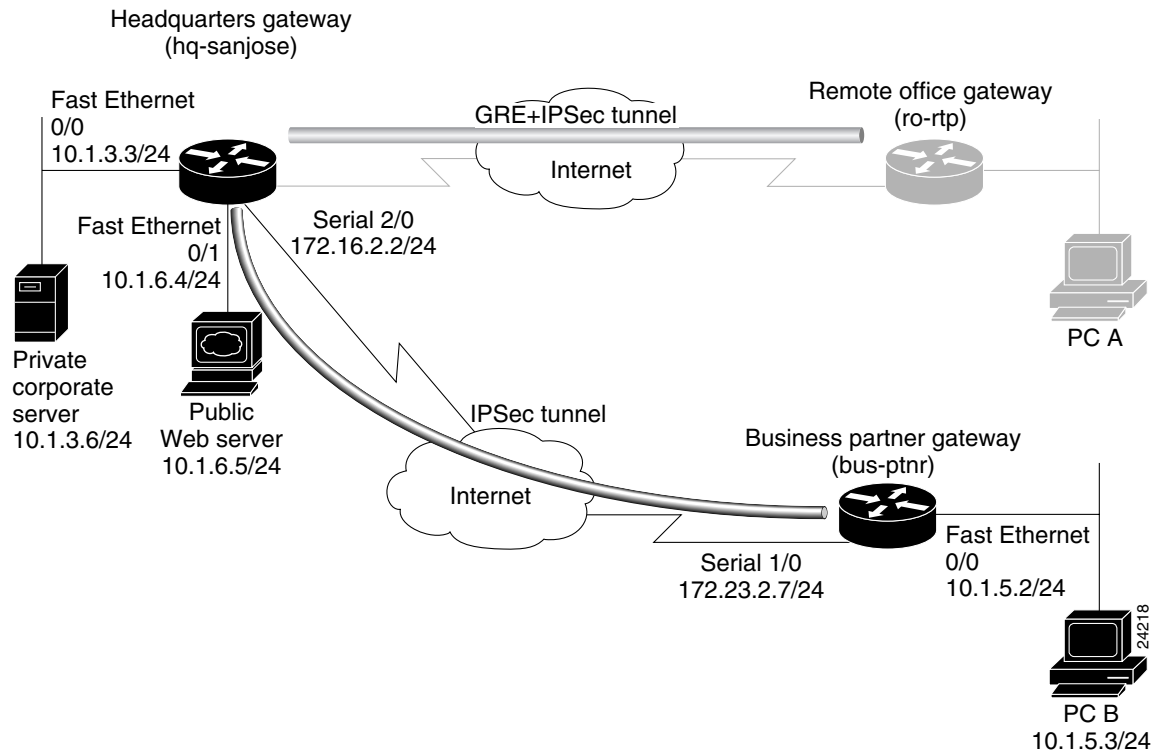

The configuration steps in the following sections are for the headquarters router, unless noted otherwise. Comprehensive configuration examples for both the headquarters and business partner routers are provided in the “[Comprehensive Configuration Examples](#)” section on page 3-39.

Table 3-2 lists the extranet scenario's physical elements.

Table 3-2 Physical Elements

Headquarters Network			Business Partner Network		
Site Hardware	WAN IP Address	Ethernet IP Address	Site Hardware	WAN IP Address	Ethernet IP Address
hq-sanjose	Serial interface 2/0: 172.16.2.2 255.255.255.0	Fast Ethernet Interface 0/0: 10.1.3.3 255.255.255.0 Fast Ethernet Interface 0/1: 10.1.6.4 255.255.255.0	bus-ptnr	Serial interface 1/0: 172.23.2.7 255.255.255.0	Fast Ethernet Interface 0/0: 10.1.5.2 255.255.255.0
Corporate server	—	10.1.3.6	PC B	—	10.1.5.3
Web server	—	10.1.6.5 ¹			

1. The inside local IP address of the headquarters network public server (10.1.6.5) is translated to inside global IP address 10.2.2.2 in the “[Step 2—Configuring Network Address Translation](#)” section on page 3-10.

Step 1—Configuring the Tunnel

Tunneling provides a way to encapsulate packets inside of a transport protocol. Tunneling is implemented as a virtual interface to provide a simple interface for configuration. The tunnel interface is not tied to specific “passenger” or “transport” protocols, but rather, it is an architecture that is designed to provide the services necessary to implement any standard point-to-point encapsulation scheme. Because tunnels are point-to-point links, you must configure a separate tunnel for each link.

Tunneling has the following three primary components:

- Passenger protocol, which is the protocol you are encapsulating (AppleTalk, Banyan VINES, Connectionless Network Service [CLNS], DECnet, IP, or Internetwork Packet Exchange [IPX]).
- Carrier protocol, such as the generic routing encapsulation (GRE) protocol or IPSec protocol.
- Transport protocol, such as IP, which is the protocol used to carry the encapsulated protocol.

Figure 3-5 illustrates IP tunneling terminology and concepts.

Figure 3-5 IP Tunneling Terminology and Concepts

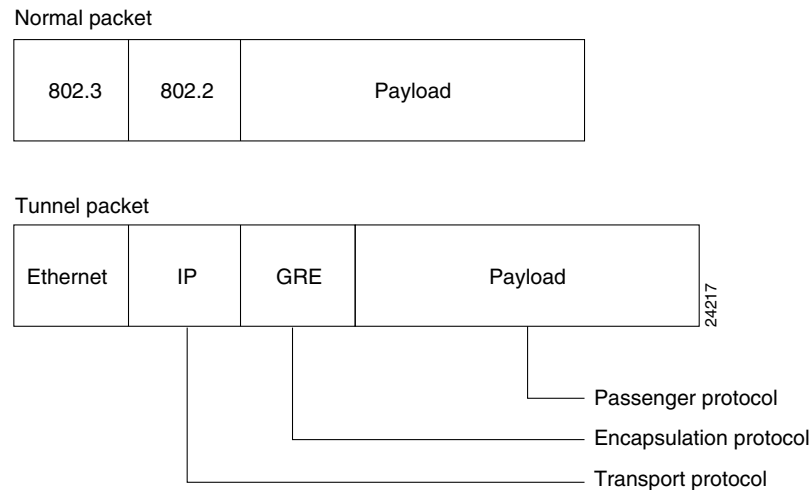

This section contains the following topics:

- [Configuring a GRE Tunnel](#)
- [Configuring an IPSec Tunnel](#)

Configuring a GRE Tunnel

GRE is capable of handling the transportation of multiprotocol and IP multicast traffic between two sites, which only have IP unicast connectivity. The importance of using tunnels in a VPN environment is based on the fact that IPSec encryption only works on IP unicast frames. Tunneling allows for the encryption and the transportation of multiprotocol traffic across the VPN since the tunneled packets appear to the IP network as an IP unicast frame between the tunnel endpoints. If all connectivity must go through the home Cisco 7200 series router, tunnels also enable the use of private network addressing across a service provider's backbone without the need for running the Network Address Translation (NAT) feature.

Network redundancy (resiliency) is an important consideration in the decision to use GRE tunnels, IPSec tunnels, or tunnels which utilize IPSec over GRE. GRE can be used in conjunction with IPSec to pass routing updates between sites on an IPSec VPN. GRE encapsulates the clear text packet, then IPSec (in transport or tunnel mode) encrypts the packet. This packet flow of IPSec over GRE enables routing updates, which are generally multicast, to be passed over an encrypted link. IPSec alone can not achieve this, because it does not support multicast.

Using redundant GRE tunnels protected by IPSec from a remote router to redundant headquarter routers, routing protocols can be employed to delineate the "primary" and "secondary" headquarter routers. Upon loss of connectivity to the primary router, routing protocols will discover the failure and route to the secondary Cisco 7200 series router, thereby providing network redundancy.

It is important to note that more than one router must be employed at HQ to provide resiliency. For VPN resilience, the remote site should be configured with two GRE tunnels, one to the primary HQ VPN router, and the other to the backup HQ VPN router.

This section contains basic steps to configure a GRE tunnel and includes the following tasks:

- [Configuring the Tunnel Interface, Source, and Destination](#)
- [Verifying the Tunnel Interface, Source, and Destination](#)

Configuring the Tunnel Interface, Source, and Destination

To configure a GRE tunnel between the headquarters and remote office routers, you must configure a tunnel interface, source, and destination on the headquarters and remote office routers. To do this, complete the following steps starting in global configuration mode.



Note

The following procedure assumes the tunnel interface, source, and destination on the remote office router are configured with the values listed in [Table 3-1](#).

	Command	Purpose
Step 1	<pre>hq-sanjose(config)# interface tunnel 0 hq-sanjose(config-if)# ip address 172.17.3.3 255.255.255.0</pre>	Specify a tunnel interface number, enter interface configuration mode, and configure an IP address and subnet mask on the tunnel interface. This example configures IP address and subnet mask 172.17.3.3 255.255.255.0 for tunnel interface 0 on the headquarters router.
Step 2	<pre>hq-sanjose(config-if)# tunnel source 172.17.2.4 255.255.255.0</pre>	Specify the tunnel interface source address and subnet mask. This example uses the IP address and subnet mask of T3 serial interface 1/0 of the headquarters router.
Step 3	<pre>hq-sanjose(config-if)# tunnel destination 172.24.2.5 255.255.255.0</pre>	Specify the tunnel interface destination address. This example uses the IP address and subnet mask of T3 serial interface 1/0 of the remote office router.
Step 4	<pre>hq-sanjose(config-if)# tunnel mode gre ip</pre>	Configure GRE as the tunnel mode. GRE is the default tunnel encapsulation mode, so this command is considered optional.
Step 5	<pre>hq-sanjose(config)# interface tunnel 0 hq-sanjose(config-if)# no shutdown %LINK-3-UPDOWN: Interface Tunnel0, changed state to up</pre>	Bring up the tunnel interface. ¹
Step 6	<pre>hq-sanjose(config-if)# exit hq-sanjose(config)# ip route 10.1.4.0 255.255.255.0 tunnel 0</pre>	Exit back to global configuration mode and configure traffic from the remote office network through the tunnel. This example configures traffic from the remote office Fast Ethernet network (10.1.4.0 255.255.255.0) through GRE tunnel 0.

1. This command changes the state of the tunnel interface from administratively down to up.



Note

When configuring GRE, you must have only Cisco routers or access servers at both ends of the tunnel connection.

Verifying the Tunnel Interface, Source, and Destination

To verify the configuration:

- Enter the **show interfaces tunnel 0 EXEC** command to view the tunnel interface status, configured IP addresses, and encapsulation type. Both the interface and the interface line protocol should be “up.”

```
ski03_7206#show interfaces tunnel 1
Tunnel1 is up, line protocol is up
Hardware is Tunnel
MTU 1514 bytes, BW 9 Kbit, DLY 500000 usec,
reliability 255/255, txload 1/255, rxload 1/255
Encapsulation TUNNEL, loopback not set
Keepalive not set
Tunnel source 1101:1::1, destination 1501:1::1
Tunnel protocol/transport IPSEC/IPV6
Tunnel TTL 255
Tunnel transmit bandwidth 8000 (kbps)
Tunnel receive bandwidth 8000 (kbps)
Tunnel protection via IPSec (profile "tunpro")
Last input 00:08:23, output 00:04:28, output hang never
Last clearing of "show interface" counters never
Input queue: 0/75/0/0 (size/max/drops/flushes); Total output drops: 3
Queueing strategy: fifo
Output queue: 0/0 (size/max)
5 minute input rate 0 bits/sec, 0 packets/sec
5 minute output rate 0 bits/sec, 0 packets/sec
39 packets input, 22734 bytes, 0 no buffer
Received 0 broadcasts, 0 runts, 0 giants, 0 throttles
0 input errors, 0 CRC, 0 frame, 0 overrun, 0 ignored, 0 abort
57 packets output, 30130 bytes, 0 underruns
0 output errors, 0 collisions, 0 interface resets
0 output buffer failures, 0 output buffers swapped out
```

- Try pinging the tunnel interface of the remote office router (this example uses the IP address of tunnel interface 1 [172.24.3.6]):

```
hq-sanjose(config)# ping 172.24.3.6

Type escape sequence to abort.
Sending 5, 100-byte ICMP Echos to 172.24.3.6, timeout is 2 seconds:
!!!!
Success rate is 100 percent (5/5), round-trip min/avg/max = 4/5/8 ms
```



Tip

If you have trouble, make sure you are using the correct IP address and that you enabled the tunnel interface with the **no shutdown** command.

Configuring an IPSec Tunnel

IPSec can be configured in tunnel mode or transport mode. IPSec tunnel mode can be used as an alternative to a GRE tunnel, or in conjunction with a GRE tunnel. In IPSec tunnel mode, the entire original IP datagram is encrypted, and it becomes the payload in a new IP packet. This mode allows a network device, such as a router, to act as an IPSec proxy. That is, the router performs encryption on behalf of the hosts. The source router encrypts packets and forwards them along the IPSec tunnel. The destination router decrypts the original IP datagram and forwards it on to the destination system. Tunnel

mode protects against traffic analysis; with tunnel mode, an attacker can only determine the tunnel endpoints and not the true source and destination of the packets passing through the tunnel, even if they are the same as the tunnel endpoints.

**Note**

IPSec tunnel mode configuration instructions are described in detail in the [“Configuring IPSec and IPSec Tunnel Mode”](#) section on page 3-22.

In IPSec transport mode, only the IP payload is encrypted, and the original IP headers are left intact. (See [Figure 3-6](#).) This mode has the advantage of adding only a few bytes to each packet. It also allows devices on the public network to see the final source and destination of the packet. With this capability, you can enable special processing in the intermediate network based on the information in the IP header. However, the Layer 4 header will be encrypted, limiting the examination of the packet. Unfortunately, by passing the IP header in the clear, transport mode allows an attacker to perform some traffic analysis. (See the [“Defining Transform Sets and Configuring IPSec Tunnel Mode”](#) section on page 3-23 for an IPSec transport mode configuration example.)

Figure 3-6 IPSec in Tunnel and Transport Modes

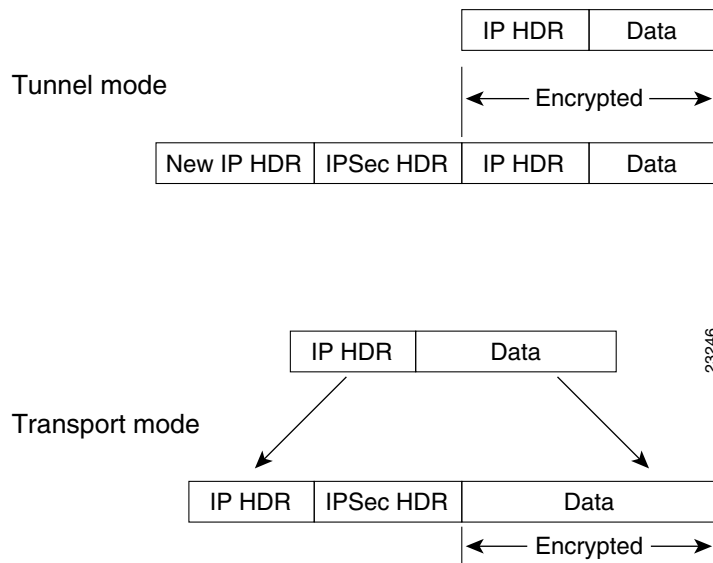

Step 2—Configuring Network Address Translation

**Note**

NAT is used if you have conflicting private address spaces in the extranet scenario. If you have no conflicting private address spaces, proceed to the [“Step 3—Configuring Encryption and IPSec”](#) section on page 3-14.

Network Address Translation (NAT) enables private IP internetworks with addresses that are not globally unique to connect to the Internet by translating those addresses into globally routable address space. NAT is configured on the router at the border of a stub domain (referred to as the *inside network*) and a public network such as the Internet (referred to as the *outside network*). NAT translates the internal

local addresses to globally unique IP addresses before sending packets to the outside network. NAT also allows a more graceful renumbering strategy for organizations that are changing service providers or voluntarily renumbering into classless interdomain routing (CIDR) blocks.

This section only explains how to configure *static translation* to translate internal local IP addresses into globally unique IP addresses before sending packets to an outside network, and includes the following tasks:

- [Configuring Static Inside Source Address Translation](#)
- [Verifying Static Inside Source Address Translation](#)

Static translation establishes a one-to-one mapping between your internal local address and an inside global address. Static translation is useful when a host on the inside must be accessible by a fixed address from the outside.

**Note**

For detailed, additional configuration information on NAT—for example, instructions on how to configure *dynamic translation*—refer to the “Configuring IP Addressing” chapter in the *Network Protocols Configuration Guide, Part 1*. NAT is also described in RFC 1631.

NAT uses the following definitions:

- **Inside local address**—The IP address that is assigned to a host on the inside network. The address is probably not a legitimate IP address assigned by the Network Information Center (NIC) or service provider.
- **Inside global address**—A legitimate IP address (assigned by the NIC or service provider) that represents one or more inside local IP addresses to the outside world.
- **Outside local address**—The IP address of an outside host as it appears to the inside network. Not necessarily a legitimate address, it was allocated from address space routable on the inside.
- **Outside global address**—The IP address assigned to a host on the outside network by the host owner. The address was allocated from a globally routable address or network space.

[Figure 3-7](#) illustrates a router that is translating a source address inside a network to a source address outside the network.

Figure 3-7 NAT Inside Source Translation

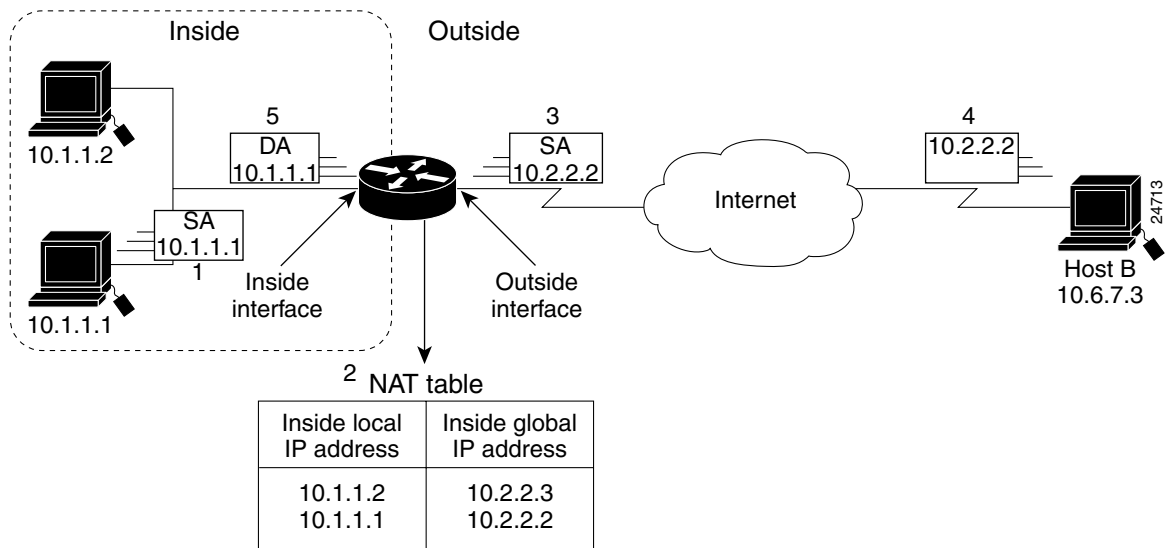

The following process describes inside source address translation, as shown in Figure 3-7:

1. The user at Host 10.1.1.1 opens a connection to Host B.
2. The first packet that the router receives from Host 10.1.1.1 causes the router to check its NAT table. If a static translation entry was configured, the router goes to Step 3. If no translation entry exists, the router determines that source address (SA) 10.1.1.1 must be translated dynamically, selects a legal, global address from the dynamic address pool, and creates a translation entry. This type of entry is called a *simple entry*.
3. The router replaces the inside local source address of Host 10.1.1.1 with the translation entry global address, and forwards the packet.
4. Host B receives the packet and responds to Host 10.1.1.1 by using the inside global IP destination address (DA) 10.2.2.2.
5. When the router receives the packet with the inside global IP address, it performs a NAT table lookup by using the inside global address as a key. It then translates the address to the inside local address of Host 10.1.1.1 and forwards the packet to Host 10.1.1.1.
6. Host 10.1.1.1 receives the packet and continues the conversation. The router performs Steps 2 through 5 for each packet.

This section contains the following topics:

- [Configuring Static Inside Source Address Translation](#)
- [Verifying Static Inside Source Address Translation](#)

Configuring Static Inside Source Address Translation

To configure static inside source address translation, complete the following steps starting in global configuration mode:

	Command	Purpose
Step 1	hq-sanjose(config)# ip nat inside source static 10.1.6.5 10.2.2.2	Establish static translation between an inside local address and an inside global address. This example translates inside local address 10.1.6.5 (the server) to inside global address 10.2.2.2.
Step 2	hq-sanjose(config)# interface fastethernet 0/1	Specify the inside interface. This example specifies Fast Ethernet interface 0/1 on the headquarters router.
Step 3	hq-sanjose(config-if)# ip nat inside	Mark the interface as connected to the inside.
Step 4	hq-sanjose(config-if)# interface serial 2/0	Specify the outside interface. This example specifies serial interface 2/0 on the headquarters router.
Step 5	hq-sanjose(config-if)# ip nat outside	Mark the interface as connected to the outside.
Step 6	hq-sanjose(config-if)# exit hq-sanjose(config)#	Exit back to global configuration mode.

The previous steps are the minimum you must configure for static inside source address translation. You could configure multiple inside and outside interfaces.

Verifying Static Inside Source Address Translation

To verify the configuration:

- Enter the **show ip nat translations verbose EXEC** command to see the global and local address translations and to confirm static translation is configured.

```
hq-sanjose# show ip nat translations verbose
Pro Inside global      Inside local      Outside local      Outside
global
--- 10.2.2.2           10.1.6.5         ---              ---
      create 00:10:28, use 00:10:28, flags:
static
```

- Enter the **show running-config EXEC** command to see the inside and outside interfaces, global and local address translations, and to confirm static translation is configured (display text has been omitted from the following sample output for clarity).

```
hq-sanjose# show running-config

interface FastEthernet0/1
 ip address 10.1.6.5 255.255.255.0
 no ip directed-broadcast
 ip nat inside

interface serial2/0
 ip address 172.16.2.2 255.255.255.0
 ip nat outside

ip nat inside source static 10.1.6.5 10.2.2.2
```

Step 3—Configuring Encryption and IPSec

IPSec is a framework of open standards, developed by the Internet Engineering Task Force (IETF), that provides data confidentiality, data integrity, and data authentication between participating peers. IPSec provides these security services at the IP layer; it uses IKE to handle negotiation of protocols and algorithms based on local policy, and to generate the encryption and authentication keys to be used by IPSec. IPSec can be used to protect one or more data flows between a pair of hosts, between a pair of security Cisco 7200 series routers, or between a security Cisco 7200 series router and a host.

IKE is a hybrid security protocol that implements Oakley and SKEME key exchanges inside the Internet Security Association and Key Management Protocol (ISAKMP) framework. While IKE can be used with other protocols, its initial implementation is with the IPSec protocol. IKE provides authentication of the IPSec peers, negotiates IPSec security associations, establishes IPSec keys, and provides IKE keepalives. IPSec can be configured without IKE, but IKE enhances IPSec by providing additional features, flexibility, ease of configuration for the IPSec standard, and keepalives, which are integral in achieving network resilience when configured with GRE.

Certification authority (CA) interoperability is provided by the ISM in support of the IPSec standard. It permits Cisco IOS devices and CAs to communicate so that your Cisco IOS device can obtain and use digital certificates from the CA. Although IPSec can be implemented in your network without the use of a CA, using a CA provides manageability and scalability for IPSec.

The CA must be properly configured to issue certificates. You must also configure the peers to obtain certificates from the CA. Configure this certificate support as described in the “Configuring Certification Authority Interoperability” chapter of the *Cisco IOS Security Configuration Guide* (see “[Related Documentation](#)” section on page x for additional information on how to access these documents).

To provide encryption and IPSec tunneling services on a Cisco 7200 series router, you must complete the following tasks:

- [Configuring IKE Policies](#)
- [Verifying IKE Policies](#)
- [Configuring IPSec and IPSec Tunnel Mode](#)
- [Configuring Crypto Maps](#)

**Note**

You can configure a static crypto map, create a dynamic crypto map, or add a dynamic crypto map into a static crypto map. Refer to the “[Configuring Crypto Maps](#)” section on page 3-24.

Optionally, you can configure CA interoperability. This guide does not explain how to configure CA interoperability on your Cisco 7200 series router. Refer to the “IP Security and Encryption” part of the *Security Configuration Guide* and the *Cisco IOS Security Command Reference* publication for detailed information on configuring CA interoperability. See “[Related Documentation](#)” section on page x for additional information on how to access these publications.

**Note**

This section only contains basic configuration information for enabling encryption and IPSec tunneling services. Refer to the “IP Security and Encryption” part of the *Cisco IOS Security Configuration Guide* and the *Security Command Reference* publications for detailed configuration information on IPSec, IKE, and CA. See “[Related Documentation](#)” section on page x for information on how to access these publications.

Refer to the *Integrated Service Adapter and Integrated Service Module Installation and Configuration* publication for detailed configuration information on the ISM.

This section contains the following topics:

- [Configuring IKE Policies](#)
- [Verifying IKE Policies](#)
- [Configuring IPSec and IPSec Tunnel Mode](#)
- [Configuring Crypto Maps](#)

Configuring IKE Policies

Internet Key Exchange (IKE) is enabled by default. IKE does not have to be enabled for individual interfaces, but is enabled globally for all interfaces in the router. You must create IKE policies at each peer. An IKE policy defines a combination of security parameters to be used during the IKE negotiation.

You can create multiple IKE policies, each with a different combination of parameter values. If you do not configure any IKE policies, the router uses the default policy, which is always set to the lowest priority, and which contains each parameter default value.

For each policy that you create, you assign a unique priority (1 through 10,000, with 1 being the highest priority). You can configure multiple policies on each peer—but at least one of these policies must contain exactly the same encryption, hash, authentication, and Diffie-Hellman parameter values as one of the policies on the remote peer. If you do not specify a value for a parameter, the default value is assigned.

IKE keepalives (or “hello packets”) are required to detect a loss of connectivity, providing network resiliency. If your HQ employs more than two routers and utilizes IPSec, you can specify the length of keepalive packets or use the default time period of 10 seconds. To specify the interval length at which keepalive packets are to be sent, use the `crypto isakmp keepalive` command, as exemplified in Step 2 of the “[Creating IKE Policies](#)” section on page 3-16.



Note

The default policy and the default values for configured policies do not show up in the configuration when you issue a `show running-config EXEC` command. Instead, to see the default policy and any default values within configured policies, use the `show crypto isakmp policy EXEC` command.

This section contains basic steps to configure IKE policies and includes the following tasks:

- [Creating IKE Policies](#)
- [Additional Configuration Required for IKE Policies](#)
- [Configuring Pre-shared Keys](#)

Creating IKE Policies

To create an IKE policy, complete the following steps starting in global configuration mode:

	Command	Purpose
Step 1	hq-sanjose(config)# crypto isakmp policy 1	Enter config-isakmp command mode and identify the policy to create. (Each policy is uniquely identified by the priority number you assign.) This example configures policy 1.
Step 2	hq-sanjose(config)# cry isakmp keepalive 12 2	Optional step: Specify the time interval of IKE keepalive packets (default is 10 seconds), and the retry interval when the keepalive packet failed. This example configures the keepalive interval for 12 seconds and the retry interval for 2 seconds.
Step 3	hq-sanjose(config-isakmp)# encryption des	Specify the encryption algorithm—56-bit Data Encryption Standard (DES [des]) or 168-bit Triple DES (3des). This example configures the DES algorithm, which is the default.
Step 4	hq-sanjose(config-isakmp)# hash sha	Specify the hash algorithm—Message Digest 5 (MD5 [md5]) or Secure Hash Algorithm (SHA [sha]). This example configures SHA, which is the default.
Step 5	hq-sanjose(config-isakmp)# authentication pre-share	Specify the authentication method—pre-shared keys (pre-share), RSA ¹ encrypted nonces (rsa-encr), or RSA signatures (rsa-slg). This example configures pre-shared keys. The default is RSA signatures.
Step 6	hq-sanjose(config-isakmp)# group 1	Specify the Diffie-Hellman group identifier—768-bit Diffie-Hellman (1) or 1024-bit Diffie-Hellman (2). This example configures 768-bit Diffie-Hellman, which is the default.
Step 7	hq-sanjose(config-isakmp)# lifetime 86400	Specify the security association's lifetime—in seconds. This example configures 86400 seconds (one day).
Step 8	hq-sanjose(config-isakmp)# exit hq-sanjose(config)#	Exit back to global configuration mode.

1. RSA = Rivest, Shamir, and Adelman.

Additional Configuration Required for IKE Policies

Depending on which authentication method you specify in your IKE policies, you need to complete an additional companion configuration before IKE and IPSec can successfully use the IKE policies.

Each authentication method requires an additional companion configuration as follows:

- RSA signatures method:

If you specify RSA signatures as the authentication method in a policy, you must configure the peers to obtain certificates from a certification authority (CA). (And, of course, the CA must be properly configured to issue the certificates.) Configure this certificate support as described in the “Configuring Certification Authority Interoperability” chapter of the *Cisco IOS Security Configuration Guide*.

The certificates are used by each peer to securely exchange public keys. (RSA signatures require that each peer has the remote peer's public signature key.) When both peers have valid certificates, they will automatically exchange public keys with each other as part of any IKE negotiation in which RSA signatures are used.

- RSA encrypted nonces method:

If you specify RSA encrypted nonces as the authentication method in a policy, you need to ensure that each peer has the other peers' public keys.

Unlike RSA signatures, the RSA encrypted nonces method does not use certificates to exchange public keys. Instead, you ensure that each peer has the others' public keys by doing the following:

- Manually configure RSA keys as described in the “Configuring Internet Key Exchange Security Protocol” chapter of the *Cisco IOS Security Configuration Guide*.
- Ensure that an IKE exchange using RSA signatures has already occurred between the peers. (The peers' public keys are exchanged during the RSA-signatures-based IKE negotiations.)

To make this happen, specify two policies: a higher-priority policy with RSA encrypted nonces, and a lower-priority policy with RSA signatures. When IKE negotiations occur, RSA signatures will be used the first time because the peers do not yet have each others' public keys. Then, future IKE negotiations will be able to use RSA-encrypted nonces because the public keys will have been exchanged.

Of course, this alternative requires that you have CA support configured.

- Pre-shared keys authentication method:

If you specify pre-shared keys as the authentication method in a policy, you must configure these pre-shared keys as described in the “[Configuring Pre-shared Keys](#)” section on page 3-17.”

- Digital certificate authentication method:

If you specify digital certificates as the authentication method in a policy, the CA must be properly configured to issue certificates. You must also configure the peers to obtain certificates from the CA. Configure this certificate support as described in the “Configuring Certification Authority Interoperability” chapter of the *Cisco IOS Security Configuration Guide*.

Digital certificates simplify authentication. You need only enroll each peer with the CA, rather than manually configuring each peer to exchange keys. Cisco recommends using digital certificates in a network of more than 50 peers.

If RSA encryption is configured and signature mode is negotiated, the peer will request both signature and encryption keys. Basically, the router will request as many keys as the configuration will support. If RSA encryption is not configured, it will just request a signature key.

Configuring Pre-shared Keys

To configure pre-shared keys, perform these steps at each peer that uses pre-shared keys in an IKE policy:

-
- Step 1** Set each peer ISAKMP identity. Each peer identity should be set to either its host name or by its IP address. By default, a peer identity is set to its IP address.

- Step 2** Specify the shared keys at each peer. Note that a given pre-shared key is shared between two peers. At a given peer, you could specify the same key to share with multiple remote peers; however, a more secure approach is to specify different keys to share between different pairs of peers.

**Note**

The following procedure is based on the “[Site-to-Site Scenario](#)” section on page 3-2. However, the same configuration commands can be used in an extranet scenario.

To specify pre-shared keys at a peer, complete the following steps in global configuration mode:

	Command	Purpose
Step 1	hq-sanjose(config)# crypto isakmp identity address	At the local peer: Specify the ISAKMP identity (address or hostname) the headquarters router will use when communicating with the remote office router during IKE negotiations. This example specifies the address keyword, which uses IP address 172.17.2.4 (serial interface 1/0 of the headquarters router) as the identity for the headquarters router.
Step 2	hq-sanjose(config)# crypto isakmp key test12345 address 172.24.2.5	At the local peer: Specify the shared key the headquarters router will use with the remote office router. This example configures the shared key test12345 to be used with the remote peer 172.24.2.5 (serial interface 1/0 on the remote office router).
Step 3	ro-rtp(config)# crypto isakmp identity address	At the remote peer: Specify the ISAKMP identity (address or hostname) the remote office router will use when communicating with the headquarters router during IKE negotiations. Again, this example specifies the address keyword, which uses IP address 172.24.2.5 (serial interface 1/0 of the remote office router) as the identity for the remote office router.
Step 4	ro-rtp(config)# crypto isakmp key test12345 address 172.17.2.4	At the remote peer: Specify the shared key to be used with the local peer. This is the same key you just specified at the local peer. This example configures the shared key test12345 to be used with the local peer 172.17.2.4 (serial interface 1/0 on the headquarters router).

**Note**

Set an ISAKMP identity whenever you specify pre-shared keys. The **address** keyword is typically used when there is only one interface (and therefore only one IP address) that will be used by the peer for IKE negotiations, and the IP address is known. Use the **hostname** keyword if there is more than one interface on the peer that might be used for IKE negotiations, or if the interface IP address is unknown (such as with dynamically-assigned IP addresses).

Configuring the Cisco 7200 Series Router for Digital Certificate Interoperability

To configure your Cisco 7200 series router to use digital certificates as the authentication method, use the following steps, beginning in global configuration mode. This configuration assumes the use of the IOS default ISAKMP policy, which uses DES, SHA, RSA signatures, Diffie-Hellman group 1, and a lifetime of 86,400 seconds. Cisco recommends using 3DES. Refer to the “[Creating IKE Policies](#)” section on page 3-16 for an ISAKMP configuration example which specifies 3DES as the encryption method.



Note

This example only configures the head-end Cisco 7200 series router. Additionally, each peer must be enrolled with a CA. This configuration example does not configure the CA. CA configuration instructions should be obtained from your CA vendor.

	Command	Purpose
Step 1	hq-sanjose(config)# crypto ca identity name	Declares a CA. The name should be the domain name of the CA. This command puts you into the ca-identity configuration mode.
Step 2	hq-sanjose(config)# enrollment url url	Specifies the URL of the CA. (The URL should include any nonstandard cgi-bin script location.)
Step 3	hq-sanjose(config)# enrollment mode ra	(Optional) Specifies RA mode if your CA system provides a registration authority (RA). The Cisco IOS software automatically determines the mode—RA or non-RA; therefore, if RA mode is used, this subcommand is written to NVRAM during "write memory."
Step 4	hq-sanjose(ca-identity)# query url url	Specifies the location of the LDAP server if your CA system provides an RA and supports the LDAP protocol.
Step 5	hq-sanjose(ca-identity)# enrollment retry period minutes	(Optional) Specifies that other peer certificates can still be accepted by your router even if the appropriate CRL is not accessible to your router.
Step 6	hq-sanjose(ca-identity)# enrollment retry count number	(Optional) Specifies how many times the router will continue to send unsuccessful certificate requests before giving up. By default, the router will never give up trying.
Step 7	hq-sanjose(ca-identity)# crl optional	(Optional) Specifies that other peers certificates can still be accepted by your router even if the appropriate CRL is not accessible to your router.
Step 8	hq-sanjose(ca-identity)# exit	Exits ca-identity configuration mode.

Verifying IKE Policies

To verify the configuration:

- Enter the **show crypto isakmp policy EXEC** command to see the default policy and any default values within configured policies.

```
hq-sanjose# show crypto isakmp policy
Protection suite priority 1
  encryption algorithm:DES - Data Encryption Standard (56 bit keys)
  hash algorithm:Secure Hash Standard
```

```
authentication method:Pre-Shared Key
Diffie-Hellman group:#1 (768 bit)
lifetime:86400 seconds, no volume limit
```

**Note**

Although the above output shows “no volume limit” for the lifetime, you can currently only configure a time lifetime (such as 86400 seconds); volume limit lifetimes are not configurable.

**Tip**

If you have trouble, use the **show version** command to ensure your Cisco 7200 series router is running a Cisco IOS software image that supports crypto.

```
ski03_7206#show version
Cisco Internetwork Operating System Software
IOS (tm) 7200 Software (C7200-JK903S-M), Version 12.3(3), RELEASE SOFTWARE (fc1)
Copyright (c) 1986-2003 by cisco Systems, Inc.
Compiled Mon 28-Jul-03 15:45 by dchih
Image text-base: 0x60008954, data-base: 0x6219E000
ROM: System Bootstrap, Version 12.1(20000710:044039) [nlaw-121E_npeb 117], DEVELOPMENT
SOFTWARE
BOOTLDR: 7200 Software (C7200-KBOOT-M), Version 12.1(8a)E, EARLY DEPLOYMENT RELEASE
SOFTWARE (fc1)
m5-7206 uptime is 0 minutes
System returned to ROM by reload at 22:20:24 UTC Wed Aug 13 2003
System image file is "tftp://17.8.16.70/images/c7200-jk9o3s-mz.123-3"
Last reload reason: Reload command
This product contains cryptographic features and is subject to United
States and local country laws governing import, export, transfer and
use. Delivery of Cisco cryptographic products does not imply
third-party authority to import, export, distribute or use encryption.
Importers, exporters, distributors and users are responsible for
compliance with U.S. and local country laws. By using this product you
agree to comply with applicable laws and regulations. If you are unable
to comply with U.S. and local laws, return this product immediately.
A summary of U.S. laws governing Cisco cryptographic products may be found at:
http://www.cisco.com/wwl/export/crypto/tool/stqrg.html
If you require further assistance please contact us by sending email to
export@cisco.com.
cisco 7206VXR (NPE400) processor (revision A) with 229376K/32768K bytes of memory.
Processor board ID 21281666
R7000 CPU at 350Mhz, Implementation 39, Rev 3.2, 256KB L2, 4096KB L3 Cache
6 slot VXR midplane, Version 2.1
Last reset from power-on
Bridging software.
X.25 software, Version 3.0.0.
SuperLAT software (copyright 1990 by Meridian Technology Corp).
TN3270 Emulation software.
PCI bus mb0_mb1 has 640 bandwidth points
PCI bus mb2 has 270 bandwidth points
WARNING: PCI bus mb0_mb1 Exceeds 600 bandwidth points
4 Ethernet/IEEE 802.3 interface(s)
2 FastEthernet/IEEE 802.3 interface(s)
2 Serial network interface(s)
1 ATM network interface(s)
1 Integrated service adapter(s)
125K bytes of non-volatile configuration memory.
125440K bytes of ATA PCMCIA card at slot 0 (Sector size 512 bytes).
8192K bytes of Flash internal SIMM (Sector size 256K).
Configuration register is 0x0
```

Configuring a Different Shared Key

Because pre-shared keys were specified as the authentication method for policy 1 in the “[Configuring IKE Policies](#)” section on page 3-15, (the policy that will also be used on the business partner router) complete the following steps at the headquarters router as well as the business partner router:

- Step 1** Set each peer Internet Security Association & Key Management Protocol (ISAKMP) identity. Each peer identity should be set to either its host name or by its IP address. By default, a peer identity is set to its IP address. In this scenario, you only need to complete this task at the *business partner* router.
- Step 2** Specify the shared keys at each peer. Note that a given pre-shared key is shared between two peers. At a given peer, you could specify the same key to share with multiple remote peers; however, a more secure approach is to specify different keys to share between different pairs of peers.



Note The following procedure is based on the “[Extranet Scenario](#)” section on page 3-4.

To configure a different pre-shared key for use between the headquarters router and the business partner router, complete the following steps in global configuration mode:

	Command	Purpose
Step 1	hq-sanjose(config)# crypto isakmp key test67890 address 172.23.2.7	At the local peer: Specify the shared key the headquarters router will use with the business partner router. This example configures the shared key test67890 to be used with the remote peer 172.23.2.7 (serial interface 1/0 on the business partner router).
Step 2	bus-ptnr(config)# crypto isakmp identity address	At the remote peer: Specify the ISAKMP identity (address or hostname) the business partner router will use when communicating with the headquarters router during IKE negotiations. (This task was already completed on the headquarters router when policy 1 was configured in the “ Configuring IKE Policies ” section on page 3-15.) This example specifies the address keyword, which uses IP address 172.23.2.7 (serial interface 1/0 of the business partner router) as the identity for the business partner router.
Step 3	bus-ptnr(config)# crypto isakmp key test67890 address 172.17.2.4	At the remote peer: Specify the shared key to be used with the local peer. This is the same key you just specified at the local peer. This example configures the shared key test67890 to be used with the local peer 172.16.2.2 (serial interface 2/0 on the headquarters router).



Note Set an ISAKMP identity whenever you specify pre-shared keys. The **address** keyword is typically used when there is only one interface (and therefore only one IP address) that will be used by the peer for IKE negotiations, and the IP address is known. Use the **hostname** keyword if there is more than one interface on the peer that might be used for IKE negotiations, or if the interface IP address is unknown (such as with dynamically-assigned IP addresses).

Configuring IPSec and IPSec Tunnel Mode

After you have configured a different shared key, configure IPSec at each participating IPSec peer. This section contains basic steps to configure IPSec and includes the following tasks:

- [Creating Crypto Access Lists](#)
- [Verifying Crypto Access Lists](#)
- [Defining Transform Sets and Configuring IPSec Tunnel Mode](#)
- [Verifying Transform Sets and IPSec Tunnel Mode](#)



Note

IKE uses User Datagram Protocol (UDP) port 500. The IPSec encapsulating security payload (ESP) and authentication header (AH) protocols use IP protocol numbers 50 and 51. Ensure that your access lists are configured so that IP protocol 50, 51, and UDP port 500 traffic is not blocked at interfaces used by IPSec. In some cases, you might need to add a statement to your access lists to explicitly permit this traffic. Crypto access lists use the same format as standard access lists. However, the **permit** command instructs the router to encrypt data, and the **deny** command instructs the router to allow unencrypted data.

Creating Crypto Access Lists

Crypto access lists are used to define which IP traffic will be protected by crypto and which traffic will not be protected by crypto. (These access lists are *not* the same as regular access lists, which determine what traffic to forward or block at an interface.) For example, you can create access lists to protect all IP traffic between the headquarters router and business partner router.

The access lists themselves are not specific to IPSec. It is the crypto map entry referencing the specific access list that defines whether IPSec processing is applied to the traffic matching a **permit** in the access list.

To create a crypto access list, enter the following command in global configuration mode:

Command	Purpose
<pre>hq-sanjose(config)# access-list 111 permit ip host 10.2.2.2 host 10.1.5.3</pre>	<p>Specify conditions to determine which IP packets are protected.¹ (Enable or disable crypto for traffic that matches these conditions.) This example configures access list 111 to encrypt all IP traffic between the headquarters server (translated inside global IP address 10.2.2.2) and PC B (IP address 10.1.5.3) in the business partner office.</p> <p>We recommend that you configure “mirror image” crypto access lists for use by IPSec and that you avoid using the any keyword.</p>

1. You specify conditions using an IP access list designated by either a number or a name. The **access-list** command designates a numbered extended access list; the **ip access-list extended** command designates a named access list.

Verifying Crypto Access Lists

To verify the configuration:

- Enter the **show access-lists 111 EXEC** command to see the access list attributes.

```
hq-sanjose# show access-lists 111
Extended IP access list 111
  permit ip host 10.2.2.2 host 10.1.5.3
```

**Tip**

If you have trouble, make sure you are specifying the correct access list number.

Defining Transform Sets and Configuring IPSec Tunnel Mode

You must define transform sets regardless of the tunneling protocol you use. To define a transform set and configure IPSec tunnel mode, complete the following steps starting in global configuration mode:

	Command	Purpose
Step 1	<pre>hq-sanjose(config)# crypto ipsec transform-set proposal4 ah-sha-hmac esp-des</pre>	<p>Define a transform set and enter crypto-transform configuration mode. This example combines AH¹ transform ah-sha-hmac, ESP² encryption transform esp-des, and ESP authentication transform esp-sha-hmac in the transform set proposal4.</p> <p>There are complex rules defining which entries you can use for the transform arguments. These rules are explained in the command description for the crypto ipsec transform-set command. You can also use the crypto ipsec transform-set? command, in global configuration mode, to view the available transform arguments.</p>
Step 2	<pre>hq-sanjose(cfg-crypto-trans)# mode tunnel</pre>	<p>Change the mode associated with the transform set. The mode setting is only applicable to traffic whose source and destination addresses are the IPSec peer addresses; it is ignored for all other traffic. (All other traffic is in tunnel mode only.) This example configures tunnel mode for the transport set proposal4, which creates an IPSec tunnel between the IPSec peer addresses.</p>
Step 3	<pre>hq-sanjose(cfg-crypto-trans)# exit hq-sanjose(config)#</pre>	<p>Exit back to global configuration mode.</p>

1. AH = authentication header. This header, when added to an IP datagram, ensures the integrity and authenticity of the data, including the invariant fields in the outer IP header. It does not provide confidentiality protection. AH uses a keyed-hash function rather than digital signatures.
2. ESP = encapsulating security payload. This header, when added to an IP datagram, protects the confidentiality, integrity, and authenticity of the data. If ESP is used to validate data integrity, it does not include the invariant fields in the IP header.

**Note**

AH and ESP can be used independently or together, although for most applications just one of them is sufficient. For both of these protocols, IPSec does not define the specific security algorithms to use, but rather, provides an open framework for implementing industry-standard algorithms.

Verifying Transform Sets and IPSec Tunnel Mode

To verify the configuration:

- Enter the **show crypto ipsec transform-set** EXEC command to see the type of transform set configured on the router.

```
hq-sanjose# show crypto ipsec transform-set
Transform set proposal4: { ah-sha-hmac }
  will negotiate = { Tunnel, },
  { esp-des esp-sha-hmac }
  will negotiate = { Tunnel, },

-Display text omitted-
```

Configuring Crypto Maps

Remote devices need to be managed through a VPN from the central site when operating on a centralized IT model. VPN devices support numerous configuration options to determine the tunnel endpoint and, depending on the method chosen, these options may impact the manageability of the network. Refer to the [“Dynamic versus Static Crypto Maps”](#) section on page 2-5 for a discussion of when to use static or dynamic crypto maps.

To be the most effective in managing remote devices, you must use static cryptographic maps at the site where your management applications are located. Dynamic cryptographic maps can be used at the headend for ease of configuration. Dynamic maps, however, accept only incoming IKE requests, and because dynamic maps cannot initiate an IKE request, it is not always guaranteed that a tunnel exists between the remote device and the headend site. Static cryptographic map configuration includes the static IP addresses of the remote peers. Thus, remote sites must use static IP addresses to support remote management.

For IPSec to succeed between two IPSec peers, both peer crypto map entries must contain compatible configuration statements.

When two peers try to establish a security association (SA), they must each have at least one crypto map entry that is compatible with one of the other peer crypto map entries. For two crypto map entries to be compatible, they must meet the following minimum criteria:

- The crypto map entries must contain compatible crypto access lists (for example, mirror image access lists). In the case where the responding peer is using dynamic crypto maps, the entries in the local crypto access list must be “permitted” by the peer crypto access list.
- The crypto map entries must each identify the other peer (unless the responding peer is using dynamic crypto maps).
- The crypto map entries must have at least one transform set in common.

When IKE is used to establish SAs, the IPSec peers can negotiate the settings they will use for the new SAs. This means that you can specify lists (such as lists of acceptable transforms) within the crypto map entry.

After you have completed configuring IPSec at each participating IPSec peer, configure crypto map entries and apply the crypto maps to interfaces.

The task of configuring IPSec at each peer can be eased by utilizing dynamic crypto maps. By configuring the head-end Cisco 7200 series router with a dynamic map, and the peers with a static map, the peer will be permitted to establish an IPSec security association even though the router does not have a crypto map entry specifically configured to meet all of the remote peer requirements.

This section contains basic steps to configure crypto maps and includes the following tasks:

- [Creating Crypto Map Entries](#)
- [Verifying Crypto Map Entries](#)
- [Applying Crypto Maps to Interfaces](#)
- [Verifying Crypto Map Interface Associations](#)

Creating Crypto Map Entries

To create crypto map entries that will use IKE to establish the SAs, complete the following steps starting in global configuration mode:

	Command	Purpose
Step 1	hq-sanjose(config)# crypto map s4second local-address serial 2/0	Create the crypto map and specify a local address (physical interface) to be used for the IPSec traffic. This example creates crypto map s4second and specifies serial interface 2/0 of the headquarters router as the local address. This step is only required if you have previously used the loopback command or if you are using GRE tunnels.
Step 2	hq-sanjose(config)# crypto map s4second 2 ipsec-isakmp	Enter crypto map configuration mode, specify a sequence number for the crypto map you created in Step 1, and configure the crypto map to use IKE to establish SAs. This example configures sequence number 2 and IKE for crypto map s4second.
Step 3	hq-sanjose(config-crypto-map)# match address 111	Specify an extended access list. This access list determines which traffic is protected by IPSec and which traffic is not be protected by IPSec. This example configures access list 111, which was created in the “Creating Crypto Access Lists” section on page 3-22.
Step 4	hq-sanjose(config-crypto-map)# set peer 172.23.2.7	Specify a remote IPSec peer (by host name or IP address). This is the peer to which IPSec protected traffic can be forwarded. This example specifies serial interface 1/0 (172.23.2.7) on the business partner router.
Step 5	hq-sanjose(config-crypto-map)# set transform-set proposal4	Specify which transform sets are allowed for this crypto map entry. List multiple transform sets in order of priority (highest priority first). This example specifies transform set proposal4, which was configured in the “Defining Transform Sets and Configuring IPSec Tunnel Mode” section on page 3-23.
Step 6	hq-sanjose(config-crypto-map)# exit hq-sanjose(config)#	Exit back to global configuration mode.

To create dynamic crypto map entries that will use IKE to establish the SAs, complete the following steps, starting in global configuration mode:

	Command	Purpose
Step 1	hq-sanjose(config)# crypto dynamic-map dynamic-map-name dynamic-seq-num	Creates a dynamic crypto map entry.

	Command	Purpose
Step 2	<pre>hq-sanjose(config)# set transform-set transform-set-name1 [transform-set-name2...transform-set-name6]</pre>	<p>Specifies which transform sets are allowed for the crypto map entry. List multiple transform sets in order of priority (highest priority first).</p> <p>This is the only configuration statement required in dynamic crypto map entries.</p>
Step 3	<pre>hq-sanjose(config-crypto-map)# match address access-list-id</pre>	<p>(Optional) Accesses list number or name of an extended access list. This access list determines which traffic should be protected by IPSec and which traffic should not be protected by IPSec security in the context of this crypto map entry.</p> <p>Note Although access-lists are optional for dynamic crypto maps, they are highly recommended.</p> <p>If the access list is configured, the data flow identity proposed by the IPSec peer must fall within a permit statement for this crypto access list.</p> <p>If the access list is not configured, the router will accept any data flow identity proposed by the IPSec peer. However, if this is configured but the specified access list does not exist or is empty, the router will drop all packets. This is similar to static crypto maps because they also require that an access list be specified.</p> <p>Care must be taken if the any keyword is used in the access list, because the access list is used for packet filtering as well as for negotiation.</p>
Step 4	<pre>hq-sanjose(config-crypto-map)# set peer {hostname ip-address}</pre>	<p>(Optional) Specifies a remote IPSec peer. Repeat for multiple remote peers.</p> <p>This is rarely configured in dynamic crypto map entries. Dynamic crypto map entries are often used for unknown remote peers.</p>
Step 5	<pre>hq-sanjose(config-crypto-map)# set security-association lifetime seconds seconds and/or set security-association lifetime kilobytes kilobytes</pre>	<p>(Optional) If you want the security associations for this crypto map to be negotiated using shorter IPSec security association lifetimes than the globally specified lifetimes, specify a key lifetime for the crypto map entry.</p>
Step 6	<pre>hq-sanjose(config-crypto-map)# exit hq-sanjose(config)#</pre>	<p>Exit back to global configuration mode.</p>

Verifying Crypto Map Entries

To verify the configuration:

- Enter the **show crypto map EXEC** command to see the crypto map entries configured on the router.

In the following example, peer 172.23.2.7 is the IP address of the remote IPSec peer. “Extended IP access list 111” lists the access list associated with the crypto map. “Current peer” indicates the current IPSec peer. “Security-association lifetime” indicates the lifetime of the SA.

“PFS N” indicates that IPSec will not negotiate perfect forward secrecy when establishing new SAs for this crypto map. “Transform sets” indicates the name of the transform set that can be used with the crypto map.

```

hq-sanjose# show crypto map
Crypto Map: "s4second" idb: Serial2/0 local address: 172.16.2.2
Crypto Map "s4second" 2 ipsec-isakmp
  Peer = 172.23.2.7
  Extended IP access list 111
    access-list 111 permit ip
      source: addr = 10.2.2.2/255.255.255.0
      dest:   addr = 10.1.5.3/255.255.255.0S
  Current peer: 172.23.2.7
  Security-association lifetime: 4608000 kilobytes/3600 seconds
  PFS (Y/N): N
  Transform sets={proposal4,}

```

--Display text omitted--



Tip

If you have trouble, make sure you are using the correct IP addresses.

Applying Crypto Maps to Interfaces

You need to apply a crypto map set to each interface through which IPSec traffic will flow. Applying the crypto map set to an interface instructs the router to evaluate all the interface traffic against the crypto map set, and to use the specified policy during connection or SA negotiation on behalf of traffic to be protected by crypto.

To apply a crypto map set to an interface, complete the following steps starting in global configuration mode:

	Command	Purpose
Step 1	hq-sanjose(config)# interface serial 2/0	Specify a physical interface on which to apply the crypto map and enter interface configuration mode. This example specifies serial interface 2/0 on the headquarters router.
Step 2	hq-sanjose(config-if)# crypto map s4second	Apply the crypto map set to the physical interface. This example configures crypto map s4second, which was created in the “Creating Crypto Map Entries” section on page 3-25.
Step 3	hq-sanjose(config-if)# exit hq-sanjose(config)#	Exit back to global configuration mode.
Step 4	hq-sanjose# clear crypto sa	In privileged EXEC mode, clear the existing IPSec SAs so that any changes are used immediately. (Manually established SAs are reestablished immediately.) Note Using the clear crypto sa command without parameters clears out the full SA database, which clears out active security sessions. You may also specify the peer , map , or entry keywords to clear out only a subset of the SA database.

Verifying Crypto Map Interface Associations

To verify the configuration:

- Enter the **show crypto map interface serial 2/0 EXEC** command to see the crypto maps applied to a specific interface.

```
hq-sanjose# show crypto map interface serial 2/0
Crypto Map "s4second" 2 ipsec-isakmp
  Peer = 172.23.2.7
  Extended IP access list 111
    access-list 111 permit ip host 10.2.2.2 host 10.1.5.3
  Current peer:172.23.2.7
  Security association lifetime:4608000 kilobytes/1000 seconds
  PFS (Y/N):N
  Transform sets={ proposal4, }
```

Step 4—Configuring Quality of Service

Cisco IOS quality of service (QoS) refers to the ability of a network to provide better service to selected network traffic over various underlying technologies including Frame Relay, Asynchronous Transfer Mode (ATM), Ethernet and 802.1 networks, SONET, and IP-routed networks. In particular, QoS features provide better and more predictable network service by:

- Supporting dedicated bandwidth
- Improving loss characteristics
- Avoiding and managing network congestion
- Shaping network traffic
- Setting traffic priorities across the network

You configure QoS features throughout a network to provide for end-to-end QoS delivery. The following three components are necessary to deliver QoS across a heterogeneous network:

- QoS within a single network element, which includes queuing, scheduling, and traffic shaping features.
- QoS signaling techniques for coordinating QoS from end-to-end between network elements.
- QoS policing and management functions to control and administer end-to-end traffic across a network.

Not all QoS techniques are appropriate for all network routers. Because edge routers and backbone routers in a network do not necessarily perform the same operations, the QoS tasks they perform might differ as well.

In general, edge routers perform the following QoS functions:

- Packet classification and prioritization
- Admission control, such as queuing and policing
- Bandwidth management

In general, backbone routers perform the following QoS functions:

- Congestion management
- Congestion avoidance

Cisco IOS QoS service models, features, and sample configurations are explained in detail in the *Quality of Service Solutions Configuration Guide* and the *Quality of Service Solutions Command Reference*. Refer to these two publications as you plan and implement a QoS strategy for your VPN, because there are various QoS service models and features that you can implement on your VPN. See “[Related Documentation](#)” section on page x for information on how to access these publications.

This section contains basic steps to configure QoS weighted fair queuing (WFQ), which applies priority (or weights) to identified traffic on the GRE tunnel you configured in the “[Step 1—Configuring the Tunnel](#)” section on page 3-6. This section also contains basic steps to configure Network-Based Application Recognition (NBAR), which is a classification engine that recognizes a wide variety of applications, including web-based and other protocols that utilize dynamic TCP/UDP port assignments.

This section includes the following topics:

- [Configuring Network-Based Application Recognition](#)
- [Configuring Weighted Fair Queuing](#)
- [Verifying Weighted Fair Queuing](#)
- [Configuring Class-Based Weighted Fair Queuing](#)
- [Verifying Class-Based Weighted Fair Queuing](#)

Configuring Network-Based Application Recognition

Network-Based Application Recognition (NBAR) adds intelligent network classification to network infrastructures. NBAR is a classification engine that recognizes a wide variety of applications, including web-based and other protocols that utilize dynamic TCP/UDP port assignments. When an application is recognized and classified by NBAR, a network can invoke services for that specific application. NBAR ensures that network bandwidth is used efficiently by working with QoS features.

Your interface to NBAR is through the modular QoS command-line interface (MQC). MQC provides a model for QoS configuration under IOS. MQC provides a clean separation between the specification of a classification policy and the specification of other policies that act based on the results of the applied classification.

Configuring a QoS policy typically requires the configuration of traffic classes, the configuration of policies that will be applied to those traffic classes, and the attaching of policies to interfaces using the commands in the sections that follow.

The following tasks are required to configure NBAR:

- [Configuring a Class Map](#)
- [Verifying a Class Map Configuration](#)
- [Configuring a Policy Map](#)
- [Attaching a Policy Map to an Interface](#)
- [Verifying a Policy Map Configuration](#)



Note

You must enable Cisco Express Forwarding (CEF) before you configure NBAR. For more information on CEF, refer to the Cisco IOS Release 12.0 configuration guide titled *Cisco IOS Switching Services Configuration Guide*.

Configuring a Class Map

Use the **class-map** configuration command to define a traffic class and the match criteria that will be used to identify traffic as belonging to that class. Match statements can include criteria such as protocol, ACL, IP precedence value, or interface identifier. The match criteria is defined with one or more of the match statements entered within the class-map configuration mode listed in the table below:

	Command	Purpose
Step 1	Router(config)# class-map <i>match-all</i> match-any <i>class-name</i>	Specifies the user-defined name of the class map. The match-all option specifies that all match criteria in the class map must be matched. The match-any option specifies that one or more match criteria must match. ¹
Step 2	Router(config-cmap)# match protocol <i>protocol-name</i>	Specifies a protocol supported by NBAR as a matching criteria.
Step 3	Router(config-cmap)# match class-map <i>class-name</i>	Specifies a class map as a matching criteria (nested class maps).

1. When neither **match-all** nor **match-any** is specified, the default is **match-all**. Use the **no class-map** command to disable the class map. Use the **no match-all** and **no match-any** commands to disable these commands within the class map. Use the **match not** command to configure a match that evaluates to true if the packet does not match the specified protocol.

Verifying a Class Map Configuration

Enter the **show class-map** command to display all class map information. You can also enter the **show class-map class-name** command to display the class map information of a user-specified class map.

Configuring a Policy Map

Use the **policy-map configuration** command to specify the QoS policies to apply to traffic classes defined by a class map. QoS policies that can be applied to traffic classification are listed in the table below.

	Command	Purpose
Step 1	Router(config)# policy-map <i>policy-name</i>	User specified policy map name.
Step 2	Router(config-pmap)# class <i>class-name</i>	Specifies the name of a previously defined class map.
Step 3	Router(config-pmap-c)# bandwidth <i>kbps</i>	Specifies a minimum bandwidth guarantee to a traffic class.
Step 4	Router(config-pmap-c)# police <i>bps conform transmit exceed drop</i>	Specifies a maximum bandwidth usage by a traffic class.
Step 5	Router(config-pmap-c)# set ip precedence {0-7}	Specifies the IP precedence of packets within a traffic class.
Step 6	outer(config-pmap-c)# set qos-group {0-99}	Specifies a QoS-group value to associate with the packet.
Step 7	Router(config-pmap-c)# random-detect	Enables weighted random early detection (WRED) drop policy for a traffic class which has a bandwidth guarantee.
Step 8	Router(config-pmap-c)# queue-limit <i>packets</i>	Specifies maximum number of packets queued for a traffic class (in the absence of random-detect).

Use the **no policy-map** command to deconfigure the policy map. Use the **no bandwidth**, **no police**, **no set**, and **no random-detect** commands to disable these commands within the policy map.

Attaching a Policy Map to an Interface

Use the **service-policy** interface configuration command to attach a policy map to an interface and to specify the direction in which the policy should be applied (on either packets coming into the interface or packets leaving the interface).

	Command	Purpose
Step 1	Router(config-if)# service-policy output <i>policy-map-name</i>	Specifies the name of the policy map to be attached to the output direction of the interface.
Step 2	Router(config-if)# service-policy input <i>policy-map-name</i>	Specifies the name of the policy map to be attached to the input direction of the interface.

Use the **no service-policy** [*input* | *output*] *policy-map-name* command to detach a policy map from an interface.

Verifying a Policy Map Configuration

Use the **show policy-map** [**interface** [*interface-spec* [*input* | *output* [**class** *class-name*]]]] command to display the configuration of a policy map and its associated class maps. Forms of this command are listed in the following table:

Command	Purpose
Router# show policy-map	Displays all configured policy maps.
Router# show policy-map <i>policy-map-name</i>	Displays the user-specified policy map.
Router# show policy-map interface	Displays statistics and configurations of all input and output policies, which are attached to an interface.
Router# show policy-map <i>interface-spec</i>	Displays configuration and statistics of the input and output policies attached to a particular interface.
Router# show policy-map <i>interface-spec</i> [<i>input</i>]	Displays configuration and statistics of the input policy attached to an interface.
Router# show policy-map <i>interface-spec</i> [<i>output</i>]	Displays configuration statistics of the output policy attached to an interface.
Router# show policy-map interface-spec [<i>input/output</i>] class <i>class-name</i>	Displays the configuration and statistics for the class name configured in the policy.

Configuring Weighted Fair Queuing

Weighted Fair Queuing (WFQ) provides traffic priority management that automatically sorts among individual traffic streams without requiring that you first define access lists. WFQ can also manage duplex data streams such as those between pairs of applications, and simplex data streams such as voice or video. There are two categories of WFQ sessions: high bandwidth and low bandwidth.

Low-bandwidth traffic has effective priority over high-bandwidth traffic, and high-bandwidth traffic shares the transmission service proportionally according to assigned weights.

When WFQ is enabled for an interface, new messages for high-bandwidth traffic streams are discarded after the configured or default congestive messages threshold has been met. However, low-bandwidth conversations, which include control message conversations, continue to enqueue data. As a result, the fair queue may occasionally contain more messages than its configured threshold number specifies.

With standard WFQ, packets are classified by flow. Packets with the same source IP address, destination IP address, source Transmission Control Protocol (TCP) or User Datagram Protocol (UDP) port, or destination TCP or UDP port belong to the same flow. WFQ allocates an equal share of the bandwidth to each flow. Flow-based WFQ is also called fair queuing because all flows are equally weighted.

To configure fair queuing on an interface, complete the following steps starting in global configuration mode:

	Command	Purpose
Step 1	hq-sanjose(config)# interface serial 1/0	Specify an interface and enter interface configuration mode. This example specifies serial interface 1/0 on the headquarters router.
Step 2	hq-sanjose(config-if)# fair-queue	Configure fair queuing on the interface.
Step 3	hq-sanjose(config-if)# exit hq-sanjose(config)#	Exit back to global configuration mode.

Verifying Weighted Fair Queuing

To verify the configuration:

- Enter the **show interfaces serial 1/0 fair-queue EXEC** command to see information on the interface that is configured for WFQ.

```
hq-sanjose# show interfaces serial 1/0 fair-queue
Serial1/0 queue size 0
      packets output 35, drops 0
WFQ: global queue limit 401, local queue limit 200
```

- Enter the **show interfaces serial 1/0 EXEC** command to verify the queuing for the interface is WFQ.

```
hq-sanjose# show interfaces serial 1/0
Serial1/0 is up, line protocol is up
  Hardware is M2T-T3 pa

-Display text omitted-

Queueing strategy:weighted fair
Output queue:0/1000/64/0 (size/max total/threshold/drops)
  Conversations  0/0/256 (active/max active/max total)
  Reserved Conversations 0/0 (allocated/max allocated)

-Display text omitted-
```

Configuring Class-Based Weighted Fair Queuing

Class-based weighted fair queueing (CBWFQ) extends the standard WFQ functionality to provide support for user-defined traffic classes. For CBWFQ, you define traffic classes based on match criteria including protocols, access control lists (ACLs), and input interfaces. Packets satisfying the match criteria for a class constitute the traffic for that class. A queue is reserved for each class, and traffic belonging to a class is directed to that class queue.

Once a class has been defined according to its match criteria, you can assign it characteristics. To characterize a class, you assign it bandwidth, weight, and maximum packet limit. The bandwidth assigned to a class is the minimum bandwidth delivered to the class during congestion.

To characterize a class, you also specify the queue limit for that class, which is the maximum number of packets allowed to accumulate in the class queue. Packets belonging to a class are subject to the bandwidth and queue limits that characterize the class.

After a queue has reached its configured queue limit, enqueueing of additional packets to the class causes tail drop or packet drop to take effect, depending on how class policy is configured.

Tail drop is used for CBWFQ classes unless you explicitly configure policy for a class to use weighted random early detection (WRED) to drop packets as a means of avoiding congestion. Note that if you use WRED packet drop instead of tail drop for one or more classes comprising a policy map, you must ensure that WRED is not configured for the interface to which you attach that service policy.



Note

Although CBWFQ supports the use of WRED, this guide does not include WRED configuration procedures. For more information on using WRED with CBWFQ, refer to the [Cisco IOS Release 12.2 Configuration Guide Master Index](#).

If a default class is configured, all unclassified traffic is treated as belonging to the default class. If no default class is configured, then by default the traffic that does not match any of the configured classes is flow classified and given best-effort treatment. Once a packet is classified, all of the standard mechanisms that can be used to differentiate service among the classes apply.

Flow classification is standard WFQ treatment. That is, packets with the same source IP address, destination IP address, source Transmission Control Protocol (TCP) or User Datagram Protocol (UDP) port, or destination TCP or UDP port are classified as belonging to the same flow. WFQ allocates an equal share of bandwidth to each flow. Flow-based WFQ is also called fair queuing because all flows are equally weighted.

For CBWFQ, which extends the standard WFQ, the weight specified for the class becomes the weight of each packet that meets the match criteria of the class. Packets that arrive at the output interface are classified according to the match criteria filters you define, then each one is assigned the appropriate weight.

The weight for a packet belonging to a specific class is derived from the bandwidth you assigned to the class when you configured it; in this sense the weight for a class is user-configurable.

After a packet's weight is assigned, the packet is enqueued in the appropriate class queue. CBWFQ uses the weights assigned to the queued packets to ensure that the class queue is serviced fairly.

The following tasks are required to configure CBWFQ:

- Defining a Class Map
- Configuring Class Policy in the Policy Map (Tail Drop)
- Attaching the Service Policy and Enabling CBWFQ

Note

Attaching a service policy to an interface disables WFQ on that interface if WFQ is configured for the interface. For this reason, you should ensure that WFQ is not enabled on such an interface. For additional information on WFQ, see the "Configuring Weighted Fair Queuing" chapter of the [Cisco IOS Release 12.0 Quality of Service Solutions Configuration Guide](#).

Defining a Class Map

To create a class map containing match criteria against which a packet is checked to determine if it belongs to a class, and to effectively create the class whose policy can be specified in one or more policy maps, use the first command in global configuration mode to specify the class-map name. Then use one of the following commands in class-map configuration mode:

	Command	Purpose
Step 1	hq-sanjose(config)# class-map <i>class-map-name</i>	Specifies the name of the class map to be created.
Step 2	hq-sanjose(config-cmap)# match access-group <i>access-group</i>	Specifies the name of the numbered ACL against whose contents packets are checked to determine if they belong to the class.
Step 3	hq-sanjose(config-cmap)# match input-interface <i>interface-name</i>	Specifies the name of the output interface used as a match criterion against which packets are checked to determine if they belong to the class.
Step 4	hq-sanjose(config-cmap)# match protocol <i>protocol</i>	Specifies the name of the protocol used as a match criterion against which packets are checked to determine if they belong to the class.

Configuring Class Policy in the Policy Map (Tail Drop)

To configure a policy map and create class policies (including a default class) comprising the service policy, use the first global configuration command to specify the policy-map name. Then use the following policy-map configuration commands to configure policy for a standard class and the default class. For each class that you define, you can use one or more of the following policy-map configuration commands to configure class policy. For example, you might specify bandwidth for one class and both bandwidth and queue limit for another class.

The policy-map default class is the class to which traffic is directed if that traffic does not satisfy the match criteria of other classes whose policy is defined in the policy map. To configure policy for more than one class in the same policy map, repeat Steps 2 through 4. Note that because this set of commands uses queue-limit, the policy map uses tail drop for both class policies, not WRED packet drop.

To attach a service policy to an interface and enable CBWFQ on the interface, you must create a policy map. You can configure class policies for as many classes as are defined on the router up to the maximum of 64.

	Command	Purpose
Step 1	hq-sanjose(config)# policy-map policy-map	Specifies the name of the policy map to be created or modified.
Step 2	hq-sanjose(config-pmap)# class class-name	Specifies the name of a class to be created and included in the service policy.
Step 3	hq-sanjose(config-pmap-c)# bandwidth bandwidth-kbps	Specifies the amount of bandwidth in kilobits per second (kbps) to be assigned to the class.
Step 4	hq-sanjose(config-pmap-c)# queue-limit number-of-packets	Specifies the maximum number of packets that can be enqueued for the class.
Step 5	hq-sanjose(config-pmap)# class class-default default-class-name	Specifies the default class in order to configure its policy.
Step 6	hq-sanjose(config-pmap-c)# bandwidth bandwidth-kbps	Specifies the amount of bandwidth in kilobits per second to be assigned to the default class.
Step 7	hq-sanjose(config-pmap-c)# queue-limit number-of-packets	Specifies the maximum number of packets that can be enqueued for the specified default class.

Attaching the Service Policy and Enabling CBWFQ

To attach a service policy to the output interface and enable CBWFQ on the interface, use the interface configuration command in the following table:

Command	Purpose
hq-sanjose(config-if)# service-policy output policy-map	Enables CBWFQ and attaches the specified service policy map to the output interface.



Note

When CBWFQ is enabled, all classes configured as part of the service policy map are installed in the fair queueing system.

Verifying Class-Based Weighted Fair Queuing

To display the contents of a specific policy map, a specific class from a specific policy map, or all policy maps configured on an interface, use one of the following global configuration commands:

Command	Purpose
hq-sanjose# show policy policy-map	Displays the configuration of all classes comprising the specified policy map.
hq-sanjose# show policy policy-map class <i>class-name</i>	Displays the configuration of the specified class of the specified policy map.
hq-sanjose# show policy interface <i>interface-name</i>	Displays the configuration of all classes configured for all policy maps on the specified interface.

Step 5—Configuring Cisco IOS Firewall Features

Cisco IOS software provides an extensive set of security features with which you can configure a simple or elaborate firewall, according to your particular requirements. When you configure Cisco IOS firewall features on your Cisco router, you turn your router into an effective, robust firewall.

Cisco IOS firewall features are designed to prevent unauthorized, external individuals from gaining access to your internal network, and to block attacks on your network, while at the same time allowing authorized users to access network resources.



Note

The Cisco Secure PIX Firewall can be used as an alternative to Cisco IOS firewall features. For detailed information on the Cisco Secure PIX Firewall, refer to the [Cisco Secure PIX Firewall](#) documentation.



Note

Although Cisco 7200 series routers support intrusion detection features, intrusion detection configuration procedures are not explained in this guide. For detailed information on intrusion detection, refer to the [Intrusion Detection Planning Guide](#).

You can use Cisco IOS firewall features to configure your Cisco IOS router as:

- An Internet firewall or part of an Internet firewall
- A firewall between groups in your internal network
- A firewall providing secure connections to or from branch offices
- A firewall between your company network and your company partners networks

Cisco IOS firewall features provide the following benefits:

- Protects internal networks from intrusion
- Monitors traffic through network perimeters
- Enables network commerce using the World Wide Web

At a minimum, you must configure basic traffic filtering to provide a basic firewall. You can configure your Cisco 7200 series router to function as a firewall by using the following Cisco IOS security features:

- Static access lists and static or dynamic extended access lists
- Lock-and-key (dynamic extended access lists)

- Reflective access lists
- TCP intercept
- Context-based access control
- Security server support
- Network address translation
- Cisco Encryption Technology
- IPSec network security
- Neighbor router authentication
- Event logging
- User authentication and authorization

**Note**

Refer to the “Traffic Filtering and Firewalls” part of the *Cisco IOS Security Configuration Guide* and the *Cisco IOS Security Command Reference* for advanced firewall configuration information. For information on how to access these documents, see “[Related Documentation](#)” section on page x.

This section explains how to configure an extended access list, which is a sequential collection of permit and deny conditions that apply to an IP address.

This section includes the following topics:

- [Creating Extended Access Lists Using Access List Numbers](#)
- [Verifying Extended Access Lists](#)
- [Applying Access Lists to Interfaces](#)
- [Verifying Extended Access Lists Are Applied Correctly](#)

**Note**

The extended access list configuration explained in this section is different from the crypto access list configuration explained in the “[Creating Crypto Access Lists](#)” section on page 3-22. Crypto access lists are used to define which IP traffic is or is not protected by crypto, while an extended access list is used to determine which IP traffic to forward or block at an interface.

The simplest connectivity to the Internet is to use a single device to provide the connectivity and firewall function to the Internet. With everything being in a single device, it is easy to address translation and termination of the VPN tunnels. Complexity arises when you need to add extra Cisco 7200 series routers to the network. This normally leads people into building a network where the corporate network touches the Internet through a network called the DMZ, or demilitarized zone.

Creating Extended Access Lists Using Access List Numbers

To create an extended access list that denies and permits certain types of traffic, complete the following steps starting in global configuration mode:

	Command	Purpose
Step 1	hq-sanjose(config)# access-list 102 deny tcp any any	Define access list 102 and configure the access list to deny all TCP traffic.

	Command	Purpose
Step 2	hq-sanjose(config)# access-list 102 deny udp any any	Configure access list 102 to deny all UDP traffic.
Step 3	hq-sanjose(config)# access-list 102 permit ip any any	Configure access list 102 to permit all IP traffic.

Verifying Extended Access Lists

To verify the configuration:

Enter the **show access-lists 102 EXEC** command to display the contents of the access list.

```
hq-sanjose# show access-list 102
Extended IP access list 102
  deny tcp any any
  deny udp any any
  permit ip any any
```

Applying Access Lists to Interfaces

After you create an access list, you can apply it to one or more interfaces. Access lists can be applied on *either* outbound or inbound interfaces.

To apply an access list inbound and outbound on an interface, complete the following steps starting in global configuration mode:

	Command	Purpose
Step 1	hq-sanjose(config)# interface serial 1/0	Specify serial interface 1/0 on the headquarters router and enter interface configuration mode.
Step 2	hq-sanjose(config-if)# ip access-group 102 in	Configure access list 102 inbound on serial interface 1/0 on the headquarters router.
Step 3	hq-sanjose(config-if)# ip access-group 102 out	Configure access list 102 outbound on serial interface 1/0 on the headquarters router.
Step 4	hq-sanjose(config-if)# exit hq-sanjose(config)#	Exit back to global configuration mode.

For inbound access lists, after receiving a packet, the Cisco IOS software checks the source address of the packet against the access list. If the access list permits the address, the software continues to process the packet. If the access list rejects the address, the software discards the packet and returns an “icmp host unreachable” message.

For outbound access lists, after receiving and routing a packet to a controlled interface, the software checks the destination address of the packet against the access list. If the access list permits the address, the software transmits the packet. If the access list rejects the address, the software discards the packet and returns an “ICMP Host Unreachable” message.

When you apply an access list that has not yet been defined to an interface, the software acts as if the access list has not been applied to the interface and will accept all packets. Be aware of this behavior if you use undefined access lists as a means of security in your network.

Verifying Extended Access Lists Are Applied Correctly

To verify the configuration:

- Enter the **show ip interface serial 1/0 EXEC** command to confirm the access list is applied correctly (inbound and outbound) on the interface.

```

hq-sanjose# show ip interface serial 1/0
Serial1/0 is up, line protocol is up
Internet address is 172.17.2.4
Broadcast address is 255.255.255.255
Address determined by setup command
Peer address is 172.24.2.5
MTU is 1500 bytes
Helper address is not set
Directed broadcast forwarding is disabled
Outgoing access list is 102
Inbound access list is 102

-Display text omitted-

```



Tip

If you have trouble, ensure that you specified the correct interface when you applied the access list.

Comprehensive Configuration Examples

Following are comprehensive sample configurations for the site-to-site and extranet scenarios.

Site-to-Site Scenario

The following sample configuration is based on the physical elements shown in [Figure 3-8](#):

Figure 3-8 Site-to-Site VPN Scenario Physical Elements

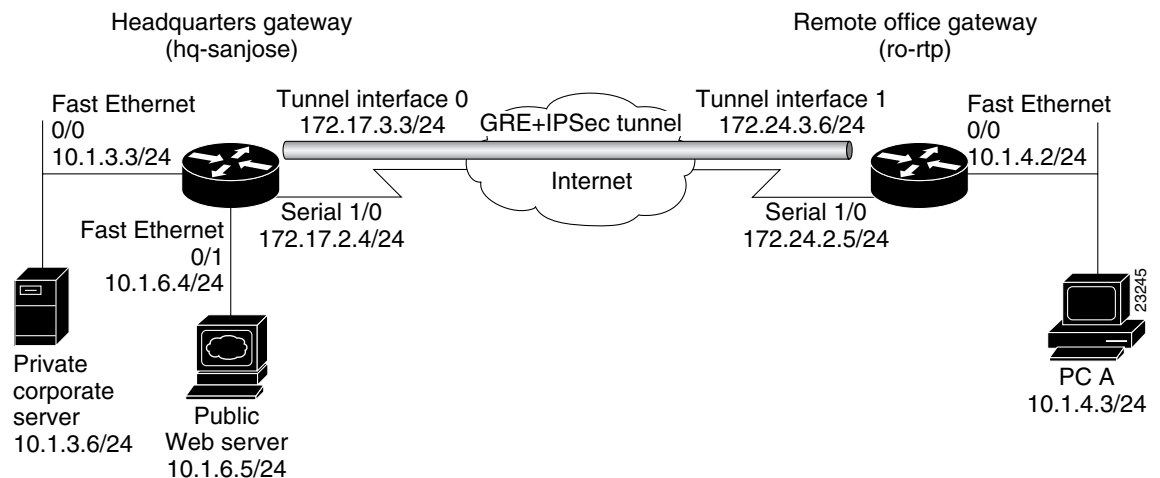

Headquarters Router Configuration

```

hq-sanjose# show running-config
Building configuration...

Current configuration:
!
version 12.0
service timestamps debug uptime
service timestamps log uptime
no service password-encryption
!
hostname hq-sanjose
!
boot system flash bootflash:
boot bootldr bootflash:c7200-jk9o3s-mz.123-3
boot config slot0:hq-sanjose-cfg-small
no logging buffered
!
crypto isakmp policy 1
 authentication pre-share
 lifetime 84600
crypto isakmp key test12345 address 172.24.2.5
!
crypto ipsec transform-set proposal1 ah-sha-hmac esp-des esp-sha-hmac
mode transport
!
!
 crypto map s1first local-address Serial1/0
 crypto map s1first 1 ipsec-isakmp
 set peer 172.24.2.5
 set transform-set proposal1
 match address 101
!
interface Tunnel0
 bandwidth 180
 ip address 172.17.3.3 255.255.255.0
 no ip directed-broadcast
 tunnel source 172.17.2.4
 tunnel destination 172.24.2.5
 crypto map s1first
!
interface FastEthernet0/0
 ip address 10.1.3.3 255.255.255.0
 no ip directed-broadcast
 no keepalive
 full-duplex
 no cdp enable
!
interface FastEthernet0/1
 ip address 10.1.6.4 255.255.255.0
 no ip directed-broadcast
 no keepalive
 full-duplex
 no cdp enable
!
interface Serial1/0
 ip address 172.17.2.4 255.255.255.0
 no ip directed-broadcast
 no ip mroute-cache
 no keepalive
 fair-queue 64 256 0
 framing c-bit

```



```

cablelength 10
dsu bandwidth 44210
clock source internal
no cdp enable
crypto map s1first
!
ip route 10.1.4.0 255.255.255.0 Tunnel0
!
access-list 101 permit gre host 172.17.2.4 host 172.24.2.5
!
line con 0
  transport input none
line aux 0
line vty 0 4
  login
!
end

```

Remote Office Router Configuration

```

ro-rtp# show running-config
Building configuration...

Current configuration:
!
version 12.0
service timestamps debug uptime
service timestamps log uptime
no service password-encryption
!
hostname ro-rtp
!
boot system flash bootflash:
boot bootldr bootflash:c7200-jk9o3s-mz.123-3
boot config slot0:ro-rtp-cfg-small
no logging buffered
!
crypto isakmp policy 1
  authentication pre-share
  lifetime 84600
crypto isakmp key test12345 address 172.17.2.4
!
crypto ipsec transform-set proposal1 ah-sha-hmac esp-des esp-sha-hmac
mode transport
!
!
crypto map s1first local-address Serial1/0
crypto map s1first 1 ipsec-isakmp
set peer 172.17.2.4
set transform-set proposal1
match address 101
!
interface Tunnel1
  bandwidth 180
  ip address 172.24.3.6 255.255.255.0
  no ip directed-broadcast
  tunnel source 172.24.2.5
  tunnel destination 172.17.2.4
  crypto map s1first
!
interface FastEthernet0/0
  ip address 10.1.4.2 255.255.255.0

```

```
no ip directed-broadcast
no keepalive
full-duplex
no cdp enable
!
interface Serial1/0
ip address 172.24.2.5 255.255.255.0
no ip directed-broadcast
no ip mroute-cache
no keepalive
fair-queue 64 256 0
framing c-bit
cablelength 10
dsu bandwidth 44210
clock source internal
no cdp enable
crypto map s1first
!
ip route 10.1.3.0 255.255.255.0 Tunnel1
ip route 10.1.6.0 255.255.255.0 Tunnel1
!
access-list 101 permit gre host 172.24.2.5 host 172.17.2.4
!
line con 0
  transport input none
line aux 0
line vty 0 4
  login
!
end
```

Extranet Scenario

The following sample configuration is based on the physical elements shown in [Figure 3-9](#):

Figure 3-9 Extranet VPN Scenario Physical Elements

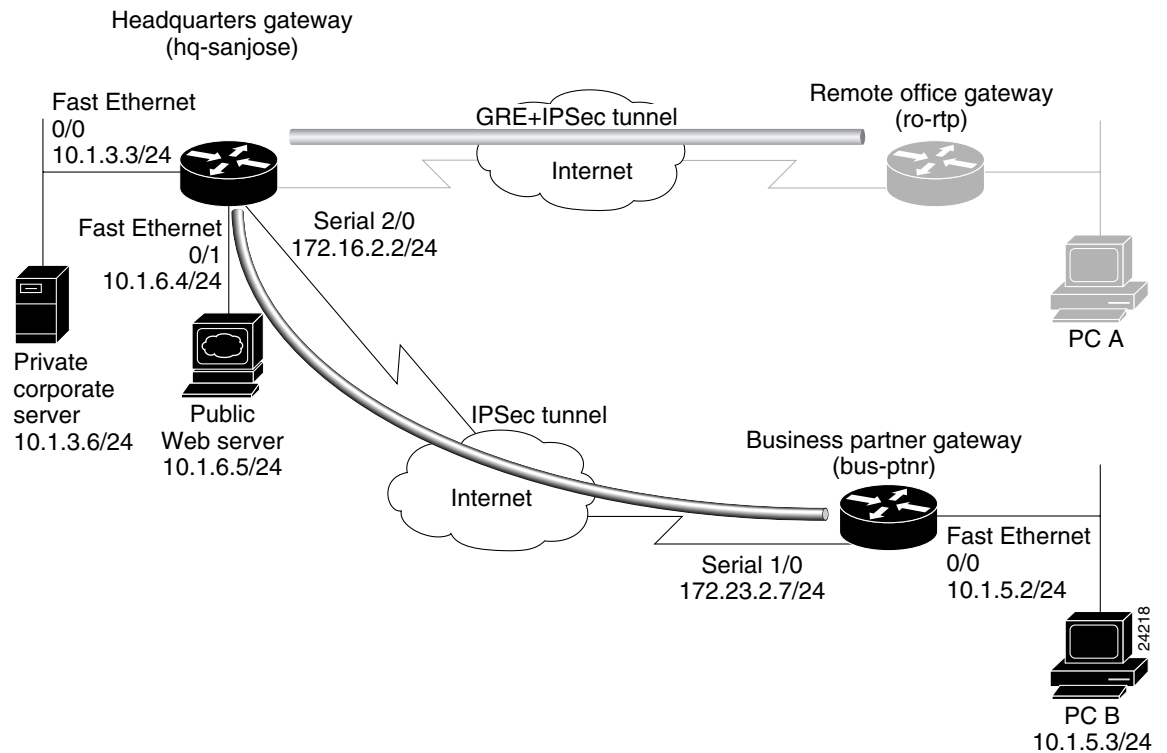

Headquarters Router Configuration

```

hq-sanjose# show running-config
Building configuration...

Current configuration:
!
version 12.0
service timestamps debug uptime
service timestamps log uptime
no service password-encryption
!
hostname hq-sanjose
!
boot system flash bootflash:
boot bootldr bootflash:c7200-jk9o3s-mz.123-3
boot config slot0:hq-sanjose-cfg-small
no logging buffered
!
crypto isakmp policy 1
 authentication pre-share
 lifetime 84600
 crypto isakmp key test12345 address 172.24.2.5

```

```

crypto isakmp key test67890 address 172.23.2.7
!
crypto ipsec transform-set proposal1 ah-sha-hmac esp-des esp-sha-hmac
mode transport
!
crypto ipsec transform-set proposal4 ah-sha-hmac esp-des esp-sha-hmac
!
!
crypto map s1first local-address Serial1/0
crypto map s1first 1 ipsec-isakmp
set peer 172.24.2.5
set transform-set proposal1
match address 101
!
crypto map s4second local-address Serial2/0
crypto map s4second 2 ipsec-isakmp
set peer 172.23.2.7
set transform-set proposal4
match address 111
!
interface Tunnel0
bandwidth 180
ip address 172.17.3.3 255.255.255.0
no ip directed-broadcast
tunnel source 172.17.2.4
tunnel destination 172.24.2.5
crypto map s1first
!
interface FastEthernet0/0
ip address 10.1.3.3 255.255.255.0
no ip directed-broadcast
no keepalive
full-duplex
no cdp enable
!
interface FastEthernet0/1
ip address 10.1.6.4 255.255.255.0
no ip directed-broadcast
ip nat inside
no keepalive
full-duplex
no cdp enable
!
interface Serial1/0
ip address 172.17.2.4 255.255.255.0
no ip directed-broadcast
no ip mroute-cache
no keepalive
fair-queue 64 256 0
framing c-bit
cablelength 10
dsu bandwidth 44210
clock source internal
no cdp enable
crypto map s1first
!
interface Serial2/0
ip address 172.16.2.2 255.255.255.0
no ip directed-broadcast
ip nat outside
no ip mroute-cache
no keepalive
fair-queue 64 256 0
framing c-bit

```

```

cablelength 10
dsu bandwidth 44210
clock source internal
no cdp enable
crypto map s4second
!
router bgp 10
 network 10.2.2.2 mask 255.255.255.0
 network 172.16.2.0 mask 255.255.255.0
!
ip route 10.1.4.0 255.255.255.0 Tunnel0
!
ip nat inside source static 10.1.6.5 10.2.2.2
!
access-list 101 permit gre host 172.17.2.4 host 172.24.2.5
access-list 111 permit ip host 10.2.2.2 host 10.1.5.3
!
line con 0
 transport input none
line aux 0
line vty 0 4
 login
!
end

```

Business Partner Router Configuration

```

bus-ptnr# show running-config
Building configuration...

Current configuration:
!
version 12.0
service timestamps debug uptime
service timestamps log uptime
no service password-encryption
!
hostname bus-ptnr
!
boot system flash bootflash:
boot bootldr bootflash:c7200-jk9o3s-mz.123-3
boot config slot0:bus-ptnr-cfg-small
no logging buffered
!
crypto isakmp policy 1
 authentication pre-share
 lifetime 84600
crypto isakmp key test67890 address 172.16.2.2
!
crypto ipsec transform-set proposal4 ah-sha-hmac esp-des esp-sha-hmac
!
!
crypto map s4second local-address Serial1/0
crypto map s4second 2 ipsec-isakmp
 set peer 172.16.2.2
 set transform-set proposal4
 match address 111
!
interface FastEthernet0/0
 ip address 10.1.5.2 255.255.255.0
 no ip directed-broadcast
 no keepalive

```

```
full-duplex
no cdp enable
!
interface Serial1/0
ip address 172.23.2.7 255.255.255.0
no ip directed-broadcast
no ip mroute-cache
no keepalive
fair-queue 64 256 0
framing c-bit
cablelength 10
dsu bandwidth 44210
clock source internal
no cdp enable
crypto map s4second
!
router bgp 10
network 10.1.5.0 mask 255.255.255.0
network 172.16.2.0 mask 255.255.255.0
!
access-list 111 permit ip host 10.1.5.3 host 10.2.2.2
!
line con 0
transport input none
line aux 0
line vty 0 4
login
!
end
```